

United States Department of the Interior
National Park Service

National Register of Historic Places
Registration Form

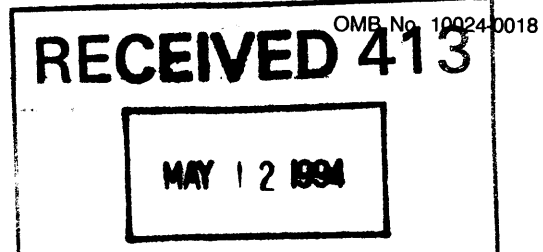

This form is for use in nominating or requesting determinations for individual properties and districts. See instructions in *How to Complete the National Register of Historic Places Registration Form* (National Register Bulletin 16A). Complete each item by marking "x" in the appropriate box or by entering the information requested. If an item does not apply to the property being documented, enter "N/A" for "not applicable." For functions, architectural classification, materials, and areas of significance, enter only categories and subcategories from the instructions. Place additional entries and narrative items on continuation sheets (NPS Form 10-900a). Use a typewriter, word processor, or computer, to complete all items.

1. Name of Property

historic name Cox Furniture Warehouse

other names/site number _____

2. Location

street & number 602 South Main Street N/A not for publication

city or town Gainesville N/A vicinity

state Florida code FL county Alachua code 001 zip code 32601

3. State/Federal Agency Certification

As the designated authority under the National Historic Preservation Act, as amended, I hereby certify that this nomination request for determination of eligibility meets the documentation standards for registering properties in the National Register of Historic Places and meets the procedural and professional requirements set forth in 36 CFR Part 60. In my opinion, the property meets does not meet the National Register criteria. I recommend that this property be considered significant nationally statewide locally. (See continuation sheet for additional comments.)
Suzanne P. Walker / Deputy SHPO 4/29/94
Signature of certifying official/Title Date
State Historic Preservation Officer, Division of Historical Resources
State of Federal agency and bureau

In my opinion, the property meets does not meet the National Register criteria. (See continuation sheet for additional comments.)

Signature of certifying official/Title Date

State or Federal agency and bureau

4. National Park Service Certification

I hereby certify that the property is:
 entered in the National Register. See continuation sheet.
 determined eligible for the National Register. See continuation sheet.
 determined not eligible for the National Register.
 removed from the National Register.
 other, (explain:)

Signature of the Keeper Edson H. Beall Date of Action 6.10.94
Entered in the National Register

Cox Furniture Warehouse
Name of Property

Alachua, Florida
County and State

RECEIVED

5. Classification

Ownership of Property
(Check as many boxes as apply)

Category of Property
(Check only one box)

Number of Resources within Property
(Do not include previously listed resources in the count.)

- private
- public local
- public State
- public Federal
- building(s)
- district
- site
- structure
- object

Contributing	Noncontributing	
1	1	buildings
		sites
		structures
		objects
1	1	Total

Name of related multiple property listing
(Enter "N/A" if property is not part of a multiple property listing.)

Number of contributing resources previously listed
in the National Register

N/A

0

6. Function or Use

Historic Functions
(Enter categories from instructions)

Current Functions
(Enter categories from instructions)

Commerce/Warehouse

Commerce/Business

7. Description

Architectural Classification
(Enter categories from instructions)

Materials
(Enter categories from instructions)

Romanesque Revival

foundation Brick

walls Brick

roof Asphalt

other Brick

Narrative Description

(Describe the historic and current condition of the property on one or more continuation sheets.)

8. Statement of Significance

Applicable National Register Criteria

(Mark "x" in one or more boxes for the criteria qualifying the property for National Register listing.)

- A Property is associated with events that have made a significant contribution to the broad patterns of our history.
- B Property is associated with the lives of persons significant in our past.
- C Property embodies the distinctive characteristics of a type, period, or method of construction or represents the work of a master, or possesses high artistic values, or represents a significant and distinguishable entity whose components lack individual distinction.
- D Property has yielded, or is likely to yield, information important in prehistory or history.

Criteria Considerations

(Mark "x" in all the boxes that apply.)

Property is:

- A owned by a religious institution or used for religious purposes.
- B removed from its original location.
- C a birthplace or grave.
- D a cemetery.
- E a reconstructed building, object, or structure.
- F a commemorative property.
- G less than 50 years of age or achieved significance within the past 50 years.

Areas of Significance

(Enter categories from instructions)

Commerce

Architecture

Period of Significance

c. 1914

Significant Dates

c. 1914

Significant Person

(Complete if Criterion B is marked above)

N/A

Cultural Affiliation

N/A

Architect/Builder

Unknown

Narrative Statement of Significance

(Explain the significance of the property on one or more continuation sheets.)

9. Major Bibliographical References

Bibliography

(Cite the books, articles, and other sources used in preparing this form on one or more continuation sheets.)

Previous documentation on file (NPS):

- preliminary determination of individual listing (36 CFR 67) has been requested
- previously listed in the National Register
- previously determined eligible by the National Register
- designated a National Historic Landmark
- recorded by Historic American Buildings Survey # _____
- recorded by Historic American Engineering Record # _____

Primary location of additional data:

- State Historic Preservation Office
- Other State agency
- Federal agency
- Local government
- University
- Other

Name of repository:

Cox Furniture Warehouse
Name of Property

Alachua, Florida
County and State

10. Geographical Data

Acreage of Property Less than one

UTM References

(Place additional UTM references on a continuation sheet.)

1

1	7
---	---

3	7	1	6	8	0
---	---	---	---	---	---

3	2	8	0	0	8	0
---	---	---	---	---	---	---

Zone Easting Northing

3

--	--

--	--	--	--	--	--

--	--	--	--	--	--	--	--

Zone Easting Northing

4

--	--

--	--	--	--	--	--

--	--	--	--	--	--	--	--

 See continuation sheet

Verbal Boundary Description

(Describe the boundaries of the property on a continuation sheet.)

Boundary Justification

(Explain why the boundaries were selected on a continuation sheet.)

11. Form Prepared By

name/title Carl Shiver, Historic Sites Specialist

organization Bureau of Historic Preservation date 2/9/94

street & number 500 South Bronough Street telephone (904) 487-2333

city or town Tallahassee state Florida zip code 32399-0250

Additional Documentation

Submit the following items with the completed form:

Continuation Sheets

Maps

A **USGS map** (7.5 or 15 minute series) indicating the property's location.

A **Sketch map** for historic districts and properties having large acreage or numerous resources.

Photographs

Representative **black and white photographs** of the property.

Additional items

(Check with the SHPO or FPO for any additional items)

Property Owner

(Complete this item at the request of SHPO or FPO.)

name Patrice Boyes

street & number 610 N.E. Boulevard telephone (904) 378-7026

city or town Gainesville state Florida zip code 32601

Paperwork Reduction Act Statement: This information is being collected for applications to the National Register of Historic Places to nominate properties for listing or determine eligibility for listing, to list properties, and to amend existing listings. Response to this request is required to obtain a benefit in accordance with the National Historic Preservation Act, as amended (16 U.S.C. 470 et seq.).

Estimated Burden Statement: Public reporting burden for this form is estimated to average 18.1 hours per response including time for reviewing instructions, gathering and maintaining data, and completing and reviewing the form. Direct comments regarding this burden estimate or any aspect of this form to the Chief, Administrative Services Division, National Park Service, P.O. Box 37127, Washington, DC 20013-7127; and the Office of Management and Budget, Paperwork Reductions Projects (1024-0018), Washington, DC 20503.

United States Department of the Interior
National Park Service

**National Register of Historic Places
Continuation Sheet**

Cox Furniture Warehouse
Gainesville, Alachua County
Description

Section number 7 Page 1

Summary Paragraph

The Cox Furniture Warehouse is a two-story, rectangular brick structure measuring 188 feet by 65 feet on the ground story. The masonry vernacular building was constructed ca. 1914 and is distinguished by Romanesque Revival style detailing on its main facade. It is located at 602 South Main Street in the oldest industrial/commercial area of Gainesville. (see photo #1) The narrow second story of the warehouse is 125 feet long and 25 feet wide and extends from the front of the building. The main (east) facade rises the full two-story height, measuring 32 feet at the highest point. A one-story storage room on the ground floor extends an additional 22 feet to the rear. The structure resembles a large basilica with its higher central portion and lower side aisles. (see photos #2, 3 and Attachment A-1, A-2)

Three arched openings framed by square pilasters and a corbeled cornice define the main entrance of the Cox Furniture Warehouse. The walls, which are composed of grey sand brick bonded with lime mortar, have weathered unevenly. Areas of the brick have crumbled or washed away, leaving voids in the wall plane surrounded by the still-existing mortar. (see photo #3)

The main (east) entrance on South Main Street is through centered wooden double doors into a small vestibule, then through another set of doors into the main interior space. Railroad tracks were built leading into the building on the south side to facilitate loading and unloading. The inside tracks are still in place, but are now covered with wood flooring. (see photo #10) This entrance has been filled in with concrete blocks, with metal casement windows set just under the roofline. (see photo #4) In addition to the entry for the freight cars, there are six additional loading doorways, 9 feet by 9 feet, on the north and south facades; one of the original doors on the north facade has also been blocked up. The original sliding wood doors with vertical iron bars above the wood panels are still in place. (see photo #6) A narrow, wood paneled door is set in the north facade, a few feet from the front sidewalk. The original wooden platform that extended across much of the south facade was replaced in the 1960s by one small covered loading dock made of concrete blocks. (see photo #4)

Evenly placed wooden double-hung windows with 2/2 sashes are all in deteriorated condition. There are 20 windows approximately 3 feet wide and 6 feet tall on the ground floor and

United States Department of the Interior
National Park ServiceNational Register of Historic Places
Continuation SheetCox Furniture Warehouse
Gainesville, Alachua County
DescriptionSection number 7 Page 2

two of the same size on the second floor above the front entrance. Two smaller windows on the south side indicate the location of a small bathroom in the warehouse. Twenty-two wooden awning windows are uniformly spaced along the north and south facades of the second story. Six metal vents are set along the top ridge of the roof. (see photo #4) Two windows fill in the side arches on the front facade, and two fixed glass oval windows are set in the inside wall of the vestibule on either side of the doorway. (see photos #3,7) For security, the first floor exterior windows have (now rusting) horizontal bars set into the wooden window frames.

The roof is gabled over the central portion, sloping at the same pitch over the side aisles. The rear extension has a hipped roof. The existing roof material is 240 lb. 20-year asphalt 3-tab shingles, installed in 1986. On the interior, the first and second floors and the roof system are supported with standard post and beam configuration, composed of three 8 x 10 heart pine beams on brick piers approximately 15 feet on center and spanning east to west. Eight- by-eight posts bear into the beams and an 8 x 8 beam bears on the posts upon which the second story floor system bears. All posts have knee braces from the top beam to the posts. Braces on either side of each column form a Y. (see photos #8-10)

The first floor of the main warehouse has 2 x 6 pine flooring on 3 x 10 heart pine joists, which bear on the beam on brick piers out in the open area. The flooring at the perimeter was deteriorated in some areas as some of the rafter ends bearing directly on the brick were deteriorated due to water damage. This problem has been corrected and the damaged flooring replaced with like material.

The interior walls, which are about 16 inches thick, are of the exposed, mostly unpainted grey sand brick. Two open stairways with no distinguishing architectural features, one in the front, one in the rear of the building, lead to the second floor. (see photo #9, 11) An exposed elevator shaft measuring approximately 6 feet by 9 feet is located in the center of the building. (see photo #8) Used for freight only, the elevator is still operable.

The second floor has unpainted 1 x 3 tongue and groove pine flooring. The ceiling beams are exposed and the sides are open, with a light wooden railing running along each side. The second story awning windows running along each side have 2 panes set in

United States Department of the Interior
National Park Service

**National Register of Historic Places
Continuation Sheet**

Cox Furniture Warehouse
Gainesville, Alachua County
Description

Section number 7 Page 3

wood frames. (see photo #12) The rear storage room on the ground floor has brick walls and exposed ceiling beams. The loading door on the north side of this area has been filled in, but the one on the south side is still operable. There are 2 windows in the rear wall.

The warehouse building is located in the extreme northeast corner of the lot, directly on the paved sidewalk on the east side of South Main Street. The site, measuring approximately 200 x 150 feet, is six blocks south of the center of the City of Gainesville, in an area that was set aside for industry and commerce in the late nineteenth century. A chain link fence encloses the partly mowed, partly lime rock parking area on the south side. The large metal storage building (ca 1948) in the southwest corner of the lot is a noncontributing structure. (see photo #13)

United States Department of the Interior
National Park Service

National Register of Historic Places
Continuation Sheet

Cox Furniture Warehouse
Gainesville, Alachua County
Photographs

Section number 7 Page 4

Photographs

Information in 1-5 is the same for all 13 photographs:

1. Cox Furniture Warehouse, 602 South Main Street
2. Gainesville (Alachua County), Florida
3. Patrice Boyes
4. 10/04/92
5. Murray Laurie
6. S. Main St., Looking North
7. Photo 1 of 13

6. East Facade and South Elevation, Looking Northwest
7. Photo 2 of 13

6. East Facade, Looking West
7. Photo 3 of 13

6. South Elevation, Looking Northwest
7. Photo 4 of 13

6. North Elevation, Looking Southeast
7. Photo 5 of 13

6. North Elevation (Detail), Looking South
7. Photo 6 of 13

6. Interior, Vestibule, Looking East
7. Photo 7 of 13

6. Interior, First Floor, Looking Northeast
7. Photo 8 of 13

6. Interior, First Floor, Looking Southeast
7. Photo 9 of 13

6. Interior, First Floor, Looking Northwest
7. Photo 10 of 13

6. Interior, First Floor Stairs, Looking South
7. Photo 11 of 13

6. Interior, Second Floor, Looking West
7. Photo 12 of 13

6. Storage Building, East Facade, Looking West.
7. Photo 13 of 13

United States Department of the Interior
National Park Service

National Register of Historic Places Continuation Sheet

Cox Furniture Warehouse
Gainesville, Alachua County
Significance

Section number 8 Page 1

Summary Paragraph

The Cox Furniture Warehouse is locally significant under criteria A and C in the areas of Architecture and Commerce because of its association with the commercial/industrial development of the City of Gainesville during the first two decades of the 20th century and as one of the few surviving examples of early 20th century warehouse design in the community. The building was constructed c. 1914 for a wholesale grocery company and is distinguished by Romanesque Revival style detailing on its main facade. The building is typical of warehouses and other commercial/industrial structures erected in the United States in the late nineteenth and early twentieth centuries.

Historical Context

The City of Gainesville was founded in 1854 when the board of Commissioners of Alachua County decided to move the county seat from Newnansville to the right-of-way of the Florida Railroad. The railroad company was in the process of constructing the state's first major rail link between the east and west coasts, starting at the city of Fernandina on the Atlantic Ocean and terminating at Cedar Key on the Gulf of Mexico. Since there was a potential for local market centers to develop along the railway, the Florida Railroad Company decided to establish five depots along the route to accommodate the shipment of local agricultural products and to encourage new settlements that would be beneficial to the railroad. The depot site selected in Alachua County was destined to become the city of Gainesville.

The new settlement was named in honor of General Edmund P. Gaines, who had served in the War of 1812 and later commanded forces during the Seminole Wars in Florida. The new town site was roughly square and contained 103 acres. The interaction of the rail line and the original town plat provided a framework for the future expansion of the community. The central business district of retail stores, offices, and hotels grew up around the courthouse square, with the first residences located nearby. To the south of the square, manufacturing concerns and warehouses took advantage of lots established for them along the railroad.

United States Department of the Interior
National Park ServiceNational Register of Historic Places
Continuation SheetSection number 8 Page 2Cox Furniture Warehouse
Gainesville, Alachua County
Significance

The Florida Railroad was completed in 1859, but Gainesville scarcely had time to enjoy the economic benefits brought by the new transportation route before the outbreak of the Civil War brought further development of the city to an end. The community did not experience its first real economic boom until the 1880s. Gainesville was only a village of 269 residents in 1860, but by 1890 the permanent population had grown to nearly 3,000 persons. Expansion of the city continued into the first decade of the 20th century, stimulated by the railroad which supported the shipment of local agricultural products, particularly cotton. Phosphate, timber, and naval stores also formed the basis for the local economy, as did the production of bricks and ironware.

The commercial center of Gainesville during the 1880s consisted largely of wooden buildings that had grown up around the courthouse square. These were subject to fires, and by the end of the century had been largely replaced by brick structures. The dilapidated old wooden warehouses along the railroad were also replaced by masonry structures. By the beginning of the second decade of the 20th century, Gainesville began to lose its importance as a regional shipping center. The growth of cotton waned in the area, and further expansion of Florida's rail network prompted the establishment of competing commercial centers in other parts of the state. The further expansion of Gainesville was assisted, in spite of this fact, by the establishment of the University of Florida, whose continued growth over the succeeding decades became the keystone of the local economy.

Statement of Significance

The Cox Furniture Warehouse is located in the Beville Addition of Gainesville, platted in 1903. It was part of the estate of Robert Harper Beville, a 30-acre tract south of the center of the city of Gainesville, which was inherited by his widow, Jane after Robert Beville's death in 1872. Mrs. Beville sold various sections of the property to expanding Gainesville businesses. In the late 1880s she sold 1/2 acre tract to J.R. Eddins who built a sawmill and planing mill on the property. The 1887 Sanborn Map shows the J.R. Eddins Planing Mill and Sash, Door and Blind Factory with a spur line from the main railroad tracks running down southwest Main Street. By 1909 Eddins had added dry kilns, and the Success Ice Company was in an adjacent lot.

United States Department of the Interior
National Park ServiceNational Register of Historic Places
Continuation SheetSection number 8 Page 3Cox Furniture Warehouse
Gainesville, Alachua County
Significance

In 1911 Jane Beville sold the northeast corner of Lot 13, measuring approximately 200 feet by 150 feet, to the Hartsfield Grocery Company. The Hartsfield Grocery Company was Gainesville's oldest and largest wholesale grocer. Established in 1908, it was owned by B.D. Hartsfield of Moultrie, Georgia, who built a 34 x 170 brick structure on the corner of North Garden and West Orange streets. The company prospered and soon outgrew the original building. Gainesville was in the heart of a rich and productive agricultural region and was served by a number of railroad lines that linked the area to markets in Florida and other states. It was an excellent distribution center for a progressive mercantile company.

The lot chosen by the Hartsfield Grocery Company for their second warehouse was a prominent and convenient one, six blocks south of the center of downtown Gainesville, on the corner of East Pine and West Main Street and on the main line of the Atlantic Coast Line railroad. Tax records indicate that the value of the lot increased from \$400 to \$4000 in 1915, indicating that the warehouse was built around 1914. Like Mr. Eddins, Hartsfield had a private spur line built so that rail cars could be driven right into the warehouse for loading and unloading. An elevator lifted heavy loads to the second floor. A storage room in the rear for highly flammable hay had a solid brick wall separating it from the main warehouse.

In 1917 the Hartsfield Grocery Company and the warehouse property were purchased by the Lewis-Chitty Wholesale Grocery Company, a Jacksonville firm. Arthur B. Chitty, the brother of prominent Gainesville businessmen, headed the company, which was expanding throughout the state. By 1925, the Lewis-Chitty Company had wholesale warehouses in seven Florida cities, including Jacksonville, Miami, and Tampa. The company provided retail stores with a wide variety of groceries, notions, tobacco, and other necessities.

The Lewis-Chitty Co. Wholesale Grocery appears on the 1922 edition of the Sanborn map of Gainesville and indicates that the building had electric lights and steam heat. Hay was stored in the rear section of the building. The rail spur that ran into the building branched off the main ACL rail line, which at that time ran down the middle of Main Street. An open loading platform was located along the south side of the building. By 1925 the Lewis-Chitty Company had sold their Gainesville

United States Department of the Interior
National Park Service

National Register of Historic Places
Continuation Sheet

Cox Furniture Warehouse
Gainesville, Alachua County
Significance

Section number 8 Page 4

warehouse to Daniel B. Cox, the owner of Cox's Furniture Store located in downtown Gainesville.

Cox was a native of Alachua County. He had attended business school in Kentucky, and after he returned to Florida taught for a time in Melrose, Micanopy, and Bell. He received the appointment of State Superintendent of Public Instruction in Tallahassee and while residing in the state capital purchased a furniture store there in 1906. He returned to Gainesville in 1917 and bought the Gainesville Furniture Company (established in 1904) whose store was located on West Main Street across from the Alachua County Courthouse. He renamed the business the Cox Furniture Store and by 1925 had purchased the large brick warehouse on South Main Street for additional storage. His was the largest store of its kind in Gainesville and accounted for 35 percent of the furniture business in the city. He established branches in Ocala and Lake City in 1932 and later opened stores in Cross City, Tallahassee, and Orlando. Mr. Cox also served in the Florida legislature.

When the main Cox Furniture Store burned in 1938, the retail business moved into the front section of the warehouse. A year later the firm relocated its retail sales back in the center of town, into the remodeled Baird Theater at the corner of East Main and Union (now 19 SE First Avenue). The warehouse was used for furniture repair and refinishing as well as storage. It later served as an outlet for discounted furniture. In 1942 the railroad tracks which had run into the building to facilitate loading and unloading were covered with wood flooring and the doorway that had admitted the rail cars was filled in with concrete blocks. The train no longer ran down Main Street after 1948, and the rail siding that ran along the side of the warehouse became obsolete. In 1990 the Cox Furniture Company ceased operations. The warehouse stood vacant until it was purchased in 1992 by the present owners who have been renovating the structure for use as offices. The renovation has been undertaken using the federal tax incentives for the rehabilitation of historic buildings.

Architectural significance

The Romanesque Revival styling on the east facade is the most impressive architectural feature of the warehouse. (see photo #3) The Romanesque Revival style was made popular in the United States in the late 19th century by Boston architect Henry

United States Department of the Interior
National Park Service

National Register of Historic Places Continuation Sheet

Cox Furniture Warehouse
Gainesville, Alachua County
Significance

Section number 8 Page 5

Hobson Richardson. The round arches that characterize the style are a reference to the Church architecture of Italy and France between the 10th and 12th centuries. Tall, corbeled brick corner pilasters and a cornice embellish the upper portion of the symmetrical facade of the Cox Warehouse. Surveys of the historic sites of Gainesville show that the Cox Furniture Warehouse is one of the few remaining masonry commercial/industrial structures that survive without major alteration in the city's original industrial district.

United States Department of the Interior
National Park ServiceNational Register of Historic Places
Continuation SheetCox Furniture Warehouse
Gainesville, Alachua County
SignificanceSection number 8 Page 4

warehouse to Daniel B. Cox, the owner of Cox's Furniture Store located in downtown Gainesville.

Cox was a native of Alachua County. He had attended business school in Kentucky, and after he returned to Florida taught for a time in Melrose, Micanopy, and Bell. He received the appointment of State Superintendent of Public Instruction in Tallahassee and while residing in the state capital purchased a furniture store there in 1906. He returned to Gainesville in 1917 and bought the Gainesville Furniture Company (established in 1904) whose store was located on West Main Street across from the Alachua County Courthouse. He renamed the business the Cox Furniture Store and by 1925 had purchased the large brick warehouse on South Main Street for additional storage. His was the largest store of its kind in Gainesville and accounted for 35 percent of the furniture business in the city. He established branches in Ocala and Lake City in 1932 and later opened stores in Cross City, Tallahassee, and Orlando. Mr. Cox also served in the Florida legislature.

When the main Cox Furniture Store burned in 1938, the retail business moved into the front section of the warehouse. A year later the firm relocated its retail sales back in the center of town, into the remodeled Baird Theater at the corner of East Main and Union (now 19 SE First Avenue). The warehouse was used for furniture repair and refinishing as well as storage. It later served as an outlet for discounted furniture. In 1942 the railroad tracks which had run into the building to facilitate loading and unloading were covered with wood flooring and the doorway that had admitted the rail cars was filled in with concrete blocks. The train no longer ran down Main Street after 1948, and the rail siding that ran along the side of the warehouse became obsolete. In 1990 the Cox Furniture Company ceased operations. The warehouse stood vacant until it was purchased in 1992 by the present owners who have been renovating the structure for use as offices. The renovation has been undertaken using the federal tax incentives for the rehabilitation of historic buildings.

Architectural significance

The Romanesque Revival styling on the east facade is the most impressive architectural feature of the warehouse. (see photo #3) The Romanesque Revival style was made popular in the United States in the late 19th century by Boston architect Henry

United States Department of the Interior
National Park Service

**National Register of Historic Places
Continuation Sheet**

Cox Furniture Warehouse
Gainesville, Alachua County
Significance

Section number 8 Page 5

Hobson Richardson. The round arches that characterize the style are a reference to the Church architecture of Italy and France between the 10th and 12th centuries. Tall, corbeled brick corner pilasters and a cornice embellish the upper portion of the symmetrical facade of the Cox Warehouse. Surveys of the historic sites of Gainesville show that the Cox Furniture Warehouse is one of the few remaining masonry commercial/industrial structures that survive without major alteration in the city's original industrial district.

United States Department of the Interior
National Park Service

National Register of Historic Places
Continuation Sheet

Cox Furniture Warehouse
Gainesville, Alachua County
Bibliography

Section number 9 Page 1

Bibliography

Alachua County Records

Brinson, Caryl. "Historic Preservation in Gainesville, Florida." Unpublished report, University of Florida Library, 1980.

Brito, Heriberto, "Cox Warehouse," Preservation project report #705, University of Florida Architecture & Fine Arts Library, 1977.

Burtz, Jessie. Burtz Gainesville Directory. Gainesville, FL: Author, 1911.

City of Gainesville Planning Division. "Preservation and Conservation Manual," 1983.

Davis, Jess G. History of Alachua County. Gainesville, FL: Alachua County Historical Society, 1966.

ERLA Associates. "City of Gainesville: Comprehensive Preservation and Conservation Plan," 1980.

Gainesville Sun (also known as The Daily Sun, Gainesville Daily Sun) various issues.

Hildreth, Charles H., and Merlin G. Cox. History of Gainesville, Florida, 1854-1979. Gainesville, FL: Alachua County Historical Society, 1981.

Lazar, Stephen F. "Urban Design Theory History" Unpublished report, University of Florida Library, 1973

Sanborn Insurance Map, Gainesville, 1887, 1903, 1909, 1922, and 1928. Originals in Map Library, University of Florida.

Schramm, C., M. Doran, L. Kent, and D. Poorman. "Cox Furniture Warehouse," Unpublished class report, University of Florida, 1988

Taylor, J. Glover. Real Estate Appraisal prepared for Cox Furniture Company, 1938.

United States Department of the Interior
National Park Service

**National Register of Historic Places
Continuation Sheet**

Section number 10 Page 1

Cox Furniture Warehouse
Gainesville, Alachua County
Boundary Description
and Justification

Boundary Description

Commencing at the Northeast corner of Block 13 of Beville's Addition to Gainesville and run thence West 200 feet; thence South 157 feet to the North line of Eddins lot as shown on the plat of said Beville's Addition; thence run Northeast along the North line of said Eddins lot to the East line of Block 13, 200 feet more or less; thence North 145 feet along the East line of Block 132 to the point of beginning, same lying and being in Section 5, Township 10 South, Range 20 East, as per plat of said Beville's Addition surveyed by A.W. Taylor in February 1903, and recorded December 15, 1903, in Plat Book A, Page 60, Alachua County Public Records.

Boundary Justification

The above described boundary encompasses all of the historic resources associated with the Cox Furniture Warehouse.

COX FURNITURE WAREHOUSE
SITE PLAN

SOUTH MAIN STREET

S.W. SIXTH AVENUE

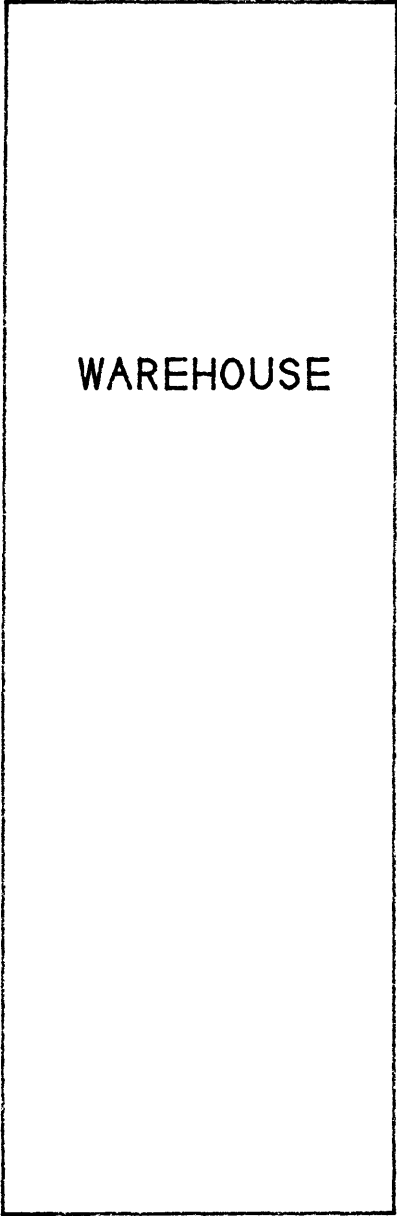

WAREHOUSE

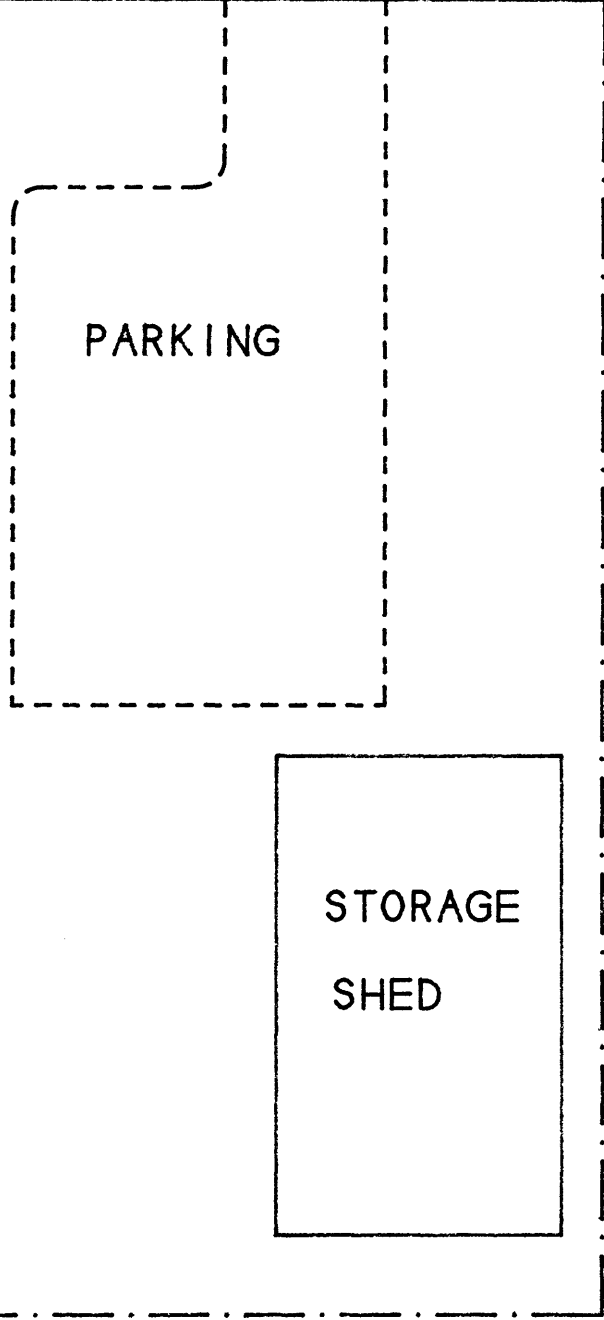

PARKING

STORAGE
SHED

PROPERTY LINE

PROPERTY LINE



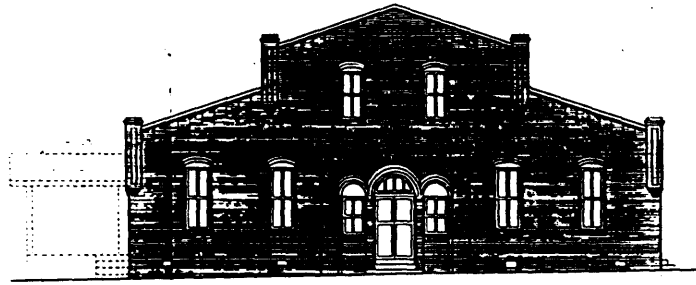

STREET (EAST) ELEVATION

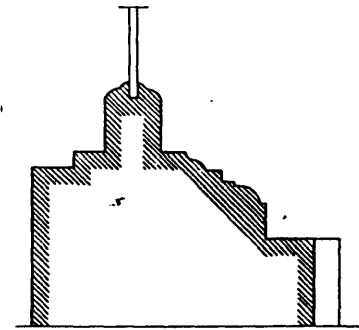
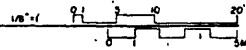

OVAL WINDOW
MOULDING

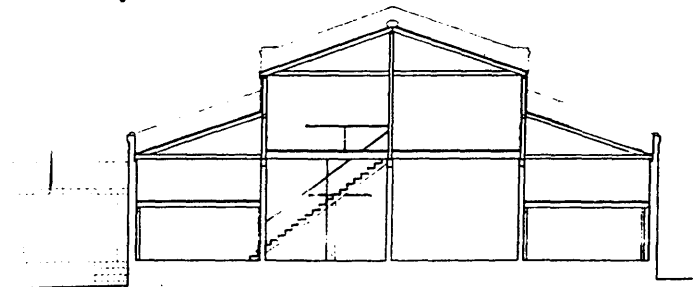
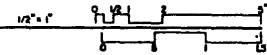

SECTION WEST VIEW

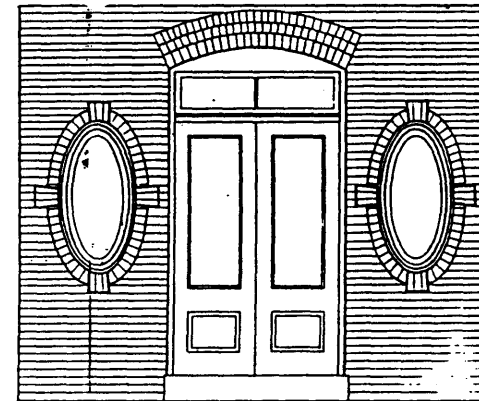
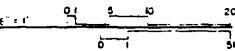

VESTIBULE INTERIOR
EAST ELEVATION

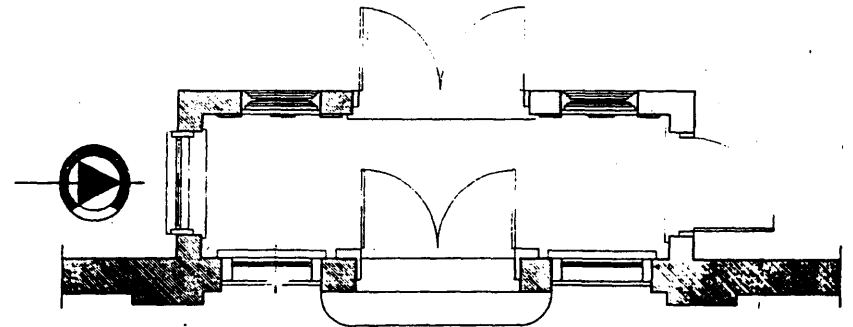
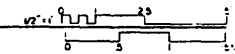

VESTIBULE PLAN

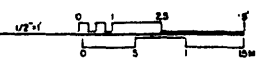

ATTACHMENT A-1

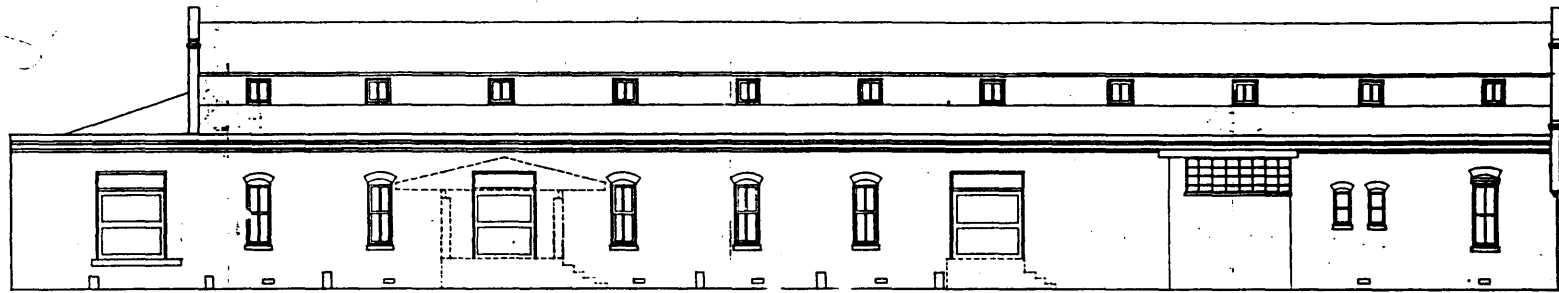

South Elevation

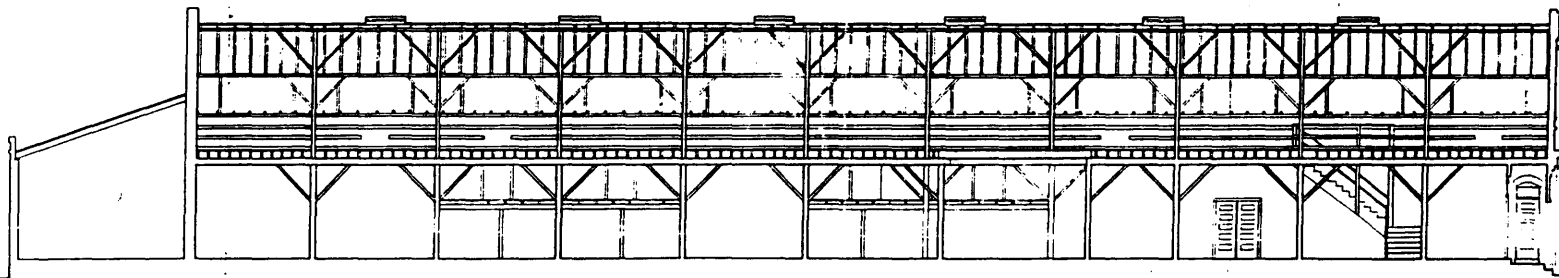

Framing Elevation

ATTACHMENT A-2

Cox Furniture Warehouse, Gainesville, FL: measured drawing of south elevation, structural framework

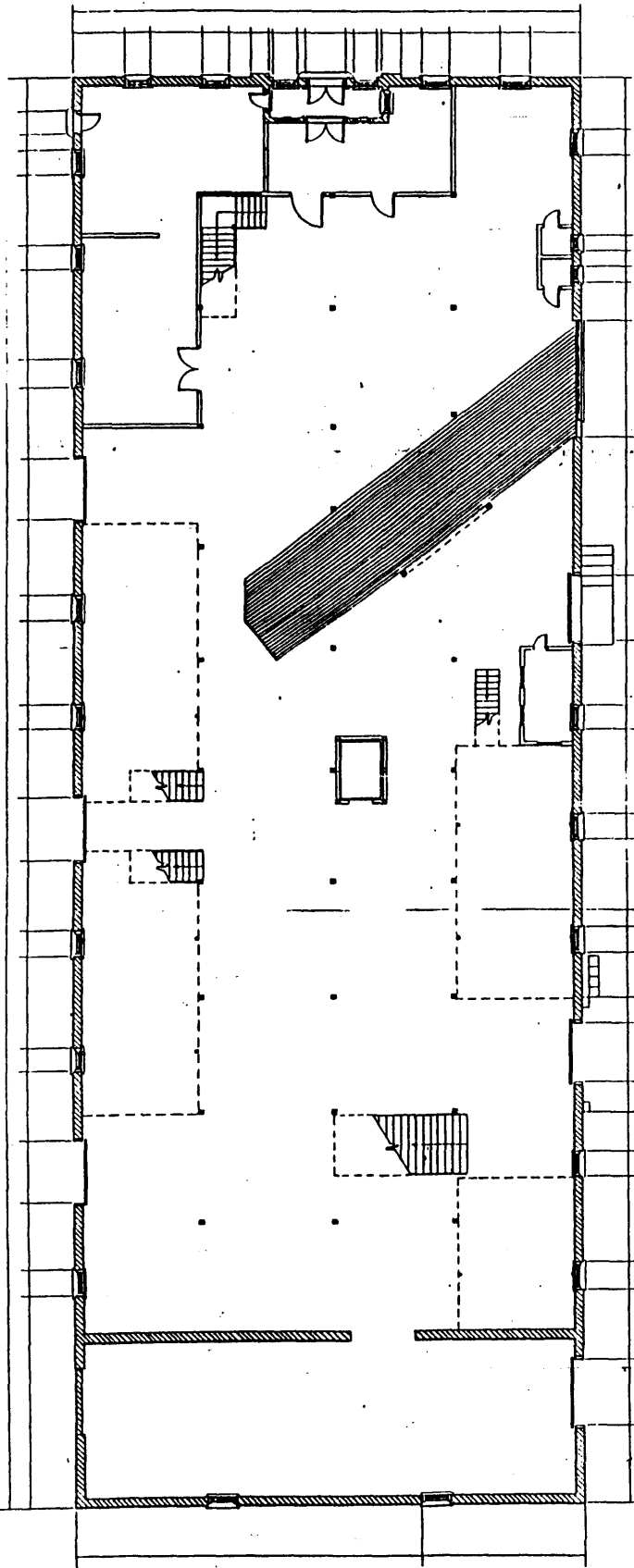

1st floor

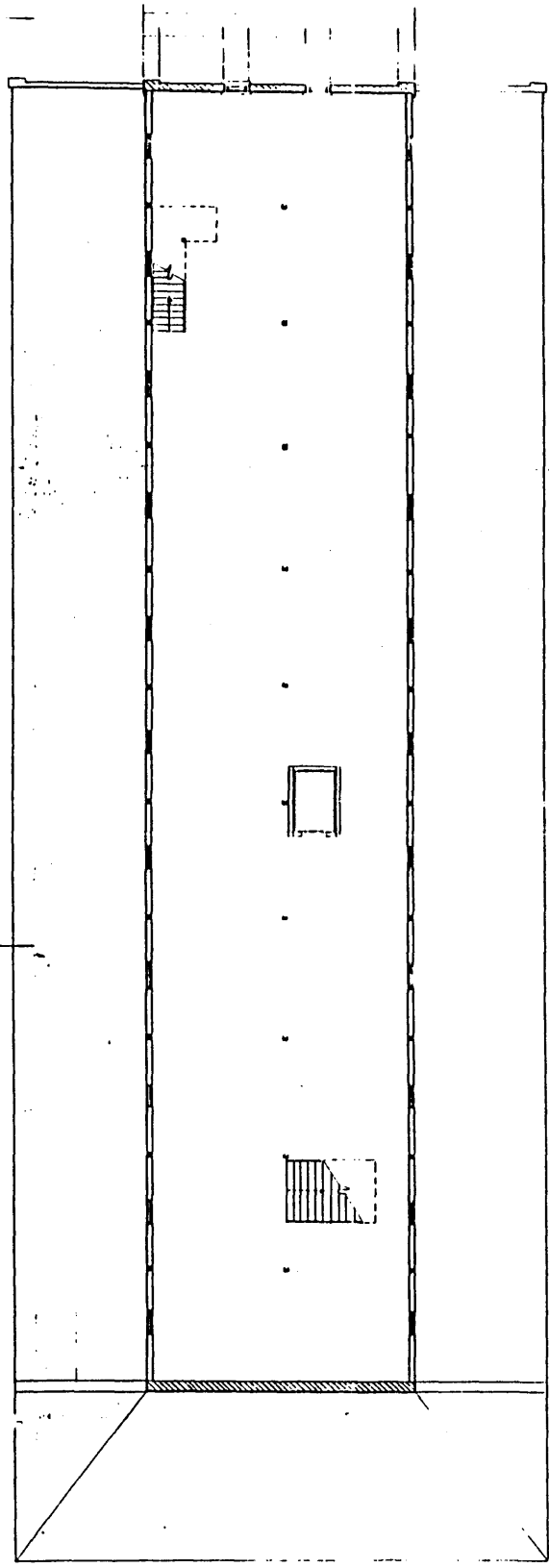

2nd floor