

United States Department of the Interior  
National Park Service

RECEIVED

National Register of Historic Places  
Registration Form

AUG 22 1988

NATIONAL  
REGISTER

This form is for use in nominating or requesting determinations of eligibility for individual properties or districts. See instructions in *Guidelines for Completing National Register Forms* (National Register Bulletin 16). Complete each item by marking "x" in the appropriate box or by entering the requested information. If an item does not apply to the property being documented, enter "N/A" for "not applicable." For functions, styles, materials, and areas of significance, enter only the categories and subcategories listed in the instructions. For additional space use continuation sheets (Form 10-900a). Type all entries.

1. Name of Property

historic name Clark-Chalker House  
other names/site number N/A

2. Location

street & number 3891 Main Street N/A  not for publication  
city, town Middleburg N/A  vicinity  
state Florida code FL county Clay code 019 zip code 32068

3. Classification

Ownership of Property	Category of Property	Number of Resources within Property	
<input checked="" type="checkbox"/> private	<input checked="" type="checkbox"/> building(s)	Contributing	Noncontributing
<input type="checkbox"/> public-local	<input type="checkbox"/> district	<u>1</u>	<u>1</u> buildings
<input type="checkbox"/> public-State	<input type="checkbox"/> site	_____	_____ sites
<input type="checkbox"/> public-Federal	<input type="checkbox"/> structure	_____	_____ structures
	<input type="checkbox"/> object	_____	_____ objects
		<u>1</u>	<u>1</u> Total

Name of related multiple property listing: N/A  
Number of contributing resources previously listed in the National Register N/A

4. State/Federal Agency Certification

As the designated authority under the National Historic Preservation Act of 1966, as amended, I hereby certify that this  nomination  request for determination of eligibility meets the documentation standards for registering properties in the National Register of Historic Places and meets the procedural and professional requirements set forth in 36 CFR Part 60. In my opinion, the property  meets  does not meet the National Register criteria.  See continuation sheet.

[Signature] Date 8/5/88  
Signature of certifying official  
State Historic Preservation Officer, Florida Department of State  
State or Federal agency and bureau

In my opinion, the property  meets  does not meet the National Register criteria.  See continuation sheet.

\_\_\_\_\_  
Signature of commenting or other official Date  
\_\_\_\_\_  
State or Federal agency and bureau

5. National Park Service Certification

I, hereby, certify that this property is:

entered in the National Register.  
 See continuation sheet.

determined eligible for the National Register.  See continuation sheet.

determined not eligible for the National Register.

removed from the National Register.

other, (explain:)

[Signature] 10/5/88  
\_\_\_\_\_  
Signature of the Keeper Date of Action

---

**6. Function or Use**

---

Historic Functions (enter categories from instructions)

Domestic - single dwelling

---

---

---

Current Functions (enter categories from instructions)

Domestic - single dwelling

---

---

---

---

**7. Description**

---

Architectural Classification

(enter categories from instructions)

No style - French Colonial

---

---

---

Materials (enter categories from instructions)

foundation brickwalls wood

---

roof metal shinglesother 

---

---

---

**Describe present and historic physical appearance.**

This two-and-one-half story, three-unit width, frame vernacular style house rests on brick piers. The ground plan is compound with rear projections from the central rectangular mass. Roofs are normal pitch, side gable and covered with metal shingles. The eaves are boxed. Post and girt framing supports the central mass and kitchen, but the rear additions have balloon frames. The principal elevation contains an incised porch with four square, masonry columns, an upper balcony, and a brick floor. There is a small shed porch at the middle of the west elevation. Vinyl siding covers three elevations, but the facade is covered with tongue-and-groove plank boards. A brick exterior gable wall chimney abuts the west elevation.

As one enters the front door, he steps into a wide hall with stairs leading to the second floor. On the west is the living room with a fireplace and mantelpiece at the west wall. The room measures 16 x 24 feet. On the east is the 12 x 16 foot music room and behind it is a 12 x 16 foot bedroom and adjoining bath.

The hall leads to an enclosed breezeway at the rear and enters a 13 x 17 foot dining room. A 10 x 17 foot kitchen connects to the dining room on the east side. A small open porch shelters the rear entrance to the kitchen; another open porch permits entry into the breezeway on the west side.

Upstairs, the wide hallway leads to two bedrooms on the east side with a bathroom in the rear and two bedrooms on the west side. A small storage room is located at the end of the hallway, and a second stairway leads to an attic that was finished with cypress boards and dry wall in 1983. It has six-over-six double-hung windows and is used as two bedrooms.

Very simple landscaping surrounds the house. The oaks and camphor trees shown in 1890s photographs have grown to majestic proportions, and the numerous azalea bushes planted by Dr. Copp in the 1930s dot the lawn. Monkey grass still lines his brick walkway leading to the front door. A four-inch, flowing artesian well lies adjacent to the closed gazebo located ten feet inside the southwest property line.

**United States Department of the Interior  
National Park Service**

**National Register of Historic Places  
Inventory—Nomination Form**

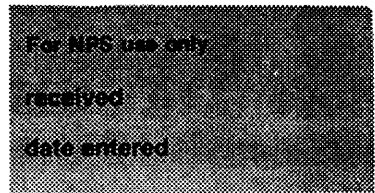

Continuation sheet

Item number 7

Page 2

Though typical of construction techniques in the early part of the 19th century, many currently rare features of the house remain unaltered. The original box house was built entirely from hand hewn heart pine. It measured 26 feet wide by 40 feet long and was two-and-one-half stories high. An incised porch and gallery ran the length of the five-bay facade. Simple square posts and railings on the porch and gallery gave the structure a French Colonial look. The porch and gallery were removed in 1936, but the remainder of the facade is intact.

Tongue-and-groove boards still cover the facade. The six-over-six double-hung sash windows remain. They have original glass, working shutters, and eighteen-inch wooden sills. Both of the matching center doors are original. They have plain surrounds and six-pane sidelights. Hand carved panels in the design of a cross decorate the front door. It also has a decorative crown.

Eight-by-eight inch, hand hewn pine timbers extend from floor to roof. They are pegged together to form the post and girt framing. The interior walls have no supporting framework, but are entirely composed of one-by-twelve inch, tongue-and-groove plank boards. All were hand hewn with carpenter planes. Two-inch-thick hand hewn pine lumber forms the floors. Square-edged planks, arranged in a ship-lap design, covered the east, west, and south elevations of the house.

Though the house has been considerably altered, most alterations are historic and the few modern alterations are reversible. During the 1890s, two rooms were added to the rear of the house and the detached kitchen was moved closer to the house and attached by an enclosed breezeway. At this time, the walls of the living room and dining room were plastered. The original center chimney was moved to the west end of the side gabled roof and a tin roof placed over the cypress shingles. The tin roof was in turn replaced with metal shingles in the 1920s. Dr. Copp installed two bathrooms, removed the gallery and added a small balcony and four two-story columns in 1936. He also replaced the wooden front porch with a brick one and built a one-hundred foot brick walkway to the house in the same year. In 1976, the bathrooms and kitchen were modernized and new tile floors laid in those rooms. Central heat and air conditioning and exterior vinyl siding were added the same year. An old storage shed was replaced in 1983.

**8. Statement of Significance**

Certifying official has considered the significance of this property in relation to other properties:

nationally  statewide  locally

Applicable National Register Criteria  A  B  C  D

Criteria Considerations (Exceptions)  A  B  C  D  E  F  G

Areas of Significance (enter categories from instructions)

Exploration/settlement  
Social History  
\_\_\_\_\_  
\_\_\_\_\_  
\_\_\_\_\_

Period of Significance

Circa 1850s-1936  
\_\_\_\_\_  
\_\_\_\_\_

Significant Dates

N/A  
\_\_\_\_\_  
\_\_\_\_\_

Cultural Affiliation

N/A  
\_\_\_\_\_  
\_\_\_\_\_

Significant Person

N/A  
\_\_\_\_\_

Architect/Builder

Unknown  
\_\_\_\_\_

State significance of property, and justify criteria, criteria considerations, and areas and periods of significance noted above.

The Clark-Chalker House meets Criterion A on the local level because it was one of the original houses built in the town of Middleburg and was associated with two of the pioneer families of the town for almost a hundred years.

Middleburg, located midway between the north and south forks of Black Creek, owed its early development to transportation. Black Creek was the largest tributary of the St. Johns River and, with an average draft of 30 to 34 feet, was navigable by ships to the forks. The town also lay on the main road from the mouth of the St. Johns to the Alachua farms in the interior. Permanent white settlement began during the Second Spanish occupation (1783-1821). One hundred and twenty-five people lived in the area then known as Black Creek or Garey's Ferry by the completion of the first United States land survey there in 1835. The stream of newcomers slowed to a trickle when the Seminole Indian Wars broke out. Fort Heileman, completed at Garey's Ferry in 1836, served as a major depot for the Army of the South during the war.

Local folklore attributes the construction of the Clark-Chalker House to Captain Michael M. Clark, the Virginia-born Quartermaster at Fort Heileman. A perusal of extant Army documents does not confirm the date of construction of the house in 1835, although extensive correspondence from Washington directs him to "construct buildings," and his accounts indicate sufficient expenditures for construction to have done so. Stars carved into the eaves of the facade of the Clark-Chalker House may have designated the house as the headquarters of Generals Winfield Scott and Thomas Jesup, who periodically stayed at Fort Heileman while they attempted to crush the Seminole uprising.

**9. Major Bibliographical References**

Previous documentation on file (NPS):

- preliminary determination of individual listing (36 CFR 67) has been requested
- previously listed in the National Register
- previously determined eligible by the National Register
- designated a National Historic Landmark
- recorded by Historic American Buildings Survey # \_\_\_\_\_
- recorded by Historic American Engineering Record # \_\_\_\_\_

See continuation sheet

Primary location of additional data:

- State historic preservation office
- Other State agency
- Federal agency
- Local government
- University
- Other

Specify repository: \_\_\_\_\_

**10. Geographical Data**

Acreage of property \_\_\_\_\_ Less than 1 acre \_\_\_\_\_

UTM References

A 

1	7	4	1	7	9	8	0	3	1	3	2	1	6	5	1	2	0
Zone				Easting				Northing									

B 

Zone				Easting				Northing									

C 

Zone				Easting				Northing									

D 

Zone				Easting				Northing									

See continuation sheet

Verbal Boundary Description

The boundary of the Clark-Chalker House is shown on the accompanying map, and is labeled "subject property".

See continuation sheet

Boundary Justification

The boundary includes the entire city lot that has historically been associated with the property.

See continuation sheet

**11. Form Prepared By**

name/title Lea Wolfe, Ph.D., Historic Sites Specialist  
organization Bureau of Historic Preservation date 6/29/88  
street & number R.A. Gray Bldg., 500 S. Bronough Street telephone (904) 487-2333  
city or town Tallahassee state Florida zip code 32399-0250

**United States Department of the Interior  
National Park Service**

**National Register of Historic Places  
Inventory—Nomination Form**

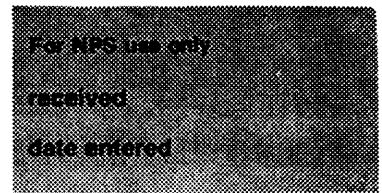

Continuation sheet

Item number 8

Page 2

Life at Garey's Ferry (Middleburg) was difficult during the war years. Frequent Indian raids in the area would drive settlers into the fort for protection. Their numbers ranged from several hundred to 1,000 people. The crowded conditions and lack of proper sanitary facilities led to hundreds of civilian deaths and fifty-four military ones. The Clark-Chalker House may also have been used as a hospital during this period.

A title search of Government Lots 2, 3, and 4 does not mention a building until November 15, 1845 when Isaac Varnes bought the property including the "old Army hospital." Fort Heileman had been abandoned on June 18, 1841 and there was great confusion over land titles in the area. Squatters on the public land were occasionally able to get titles to property, and the government land offices in St. Augustine sometimes sold the same property to different people at the same time. Middleburg was incorporated in 1845.

The written documents become much clearer when William Sims Bardin purchased the property, including the house on Main Street, on August 15, 1859 (recorded in Deed Book "A" pp. 49, 50, 51). His father William Bardin had been awarded a Spanish land grant of 200 acres near Picolata where William Sims was born on February 5, 1817. The father purchased 640 acres on Little Black Creek near Doctor's Inlet on February 22, 1826. William Sims inherited the bulk of the property upon his father's death. His daughter Martha Anne was born January 18, 1845 on the Doctor's Inlet property. She boarded with the Hoyt family at the Main Street house in Middleburg beginning in 1851. The Hoyts ran a private school for planters' children in the area. When Martha Anne was fourteen, he decided to move to town and bought the "school house."

There were only two streets, Main and Thompson, in Middleburg during the 1850s, but the town was a busy entrepot for the surrounding agricultural area. It boasted two hotels, two drugstores, nine general stores, three steam sawmills, two blacksmiths, a stable, two taverns, three churches, a grocery store, two ferries, two coopers, a physician and of course, the Hoyt School, located at the corner of Thompson and Main Streets. The major crops in the antebellum period were cotton, timber, and naval stores. The Bardins owned one of the large cotton warehouses by the ferry. Fifty-three heads of household were listed in the 1850 census.

United States Department of the Interior  
National Park Service

National Register of Historic Places  
Inventory—Nomination Form

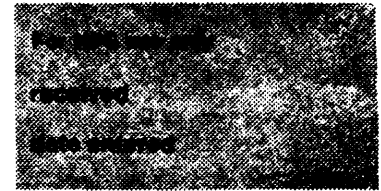

Continuation sheet

Item number 8

Page 3

One of the most prominent men in the area, William S. Bardin was a school trustee and belonged to the Odd Fellows Lodge. In the 1860s, he owned 600 acres of land, 35 slaves, and worked three freed Blacks. During his youth, he had served as a scout with Major Francis Langhorne Dade. Fortunately, he was involved in his scouting duties and avoided the infamous ambush which killed Major Dade and 108 men during the Seminole uprising. When the Civil War broke out, he enlisted with the First Florida Reserves and fought in Clay County.

The Civil War crippled Middleburg. After the war, no more than 100 people remained. Over 2000 Federal troops soldiered in Clay County during the war -- most with the Federal garrison at Magnolia. Several times General Berney's troops raided the town, burning stores and destroying contraband. Captain J.J. Dickison's Second Florida Cavalry harried the Federals and once even rescued a herd of Florida cattle that had been confiscated by Col. James Shaw and his Black soldiers. The two-hour engagement became romanticized in history as "The Battle of Tiger Head."

Though plundered of its furnishings, the Bardin home on Main Street survived the war and found new prosperity. A young man serving in the Second Florida Cavalry caught the eye of Martha Anne during the war and on Christmas Day, 1865 she and Albert Symington Chalker were married in the Bardin home. William Sims gave the house to the young couple as a wedding present and lived with them until his death in 1880.

Albert Chalker was an enterprising man. He owned the first private ferry in Florida that was chartered after the war (1865). Charging ten cents a head and one dollar for a wagon, he maintained the ferry until the county took over in 1884. Chalker also opened a general store down the block from his house on Main Street. Profits were excellent in this period. Supposedly because ferry rates and store prices were too high, a disgruntled customer burned Chalker's boat and tried to burn down the store. He was appointed Postmaster for Middleburg and served as a Justice of the Peace from 1881 to 1885. The Chalkers' prosperity increased with that of the county.

Agriculture boomed in the last two decades of the century. Truck farming, citrus, cattle, lumber, naval stores and phosphate provided the economic base for Clay County and Middleburg. By 1900 there were over 1300 residents, but the town's fortunes declined at the turn of the century because citizens refused to allow the railroad to be built through Middleburg. The population fell below 800 people and never regained its former size.

**United States Department of the Interior  
National Park Service**

**National Register of Historic Places  
Inventory—Nomination Form**

For NPS use only  
received  
date entered

Continuation sheet

Item number 8

Page 4

The Chalker family, however, continued to prosper. George Chalker took over the family store after his father's death in 1886 and his brother William Chalker became the town druggist, Clay County tax assessor and tax collector. Both lived in the family home on Main Street. Martha Anne, the family matriarch, continued to live there until her death in 1936 at age 91. She had witnessed the growth of Middleburg from its origins as a trading post and military garrison, to its prosperity as an entrepot, and its decline in the 20th century to a sleepy unincorporated village. Her grandson, Dr. Francis Allen Copp, inherited the house. He was the first plastic surgeon to practice in nearby Jacksonville, and commuted daily from the family home in Middleburg. Dr. Copp's hobby was restoring the house and furnishing it with period antiques. In 1936, he removed the gallery and added a small second floor balcony and four masonry columns to the facade.



United States Department of the Interior  
National Park Service

National Register of Historic Places  
Inventory—Nomination Form

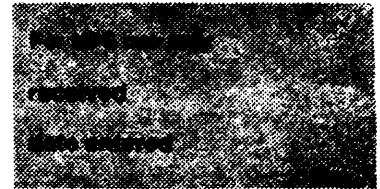

Continuation sheet

Item number 9

Page 2

BIBLIOGRAPHY

BOOKS

American State Papers: Documents, Legislative and Executive, of the Congress of the United States in Relation to the Public Lands, 5 vols., Washington, D.C., 1834.

Anonymous. Grants and Sections in Duval County Covering What is Now Clay County, n.p., 1898.

Blakey, Arch F. Parade of Memories: A History of Clay County, Florida. Jacksonville: Clay County Board of County Commissioners, 1976.

Carter, Clarence (ed.). Territorial Papers of the United States. 22 vols., Washington, D.C., 1934-1956.

Cash, W.T. Florida Becomes a State. Tallahassee: Florida Centennial Commission, 1945.

Federal Writers Project, Florida: A Guide to the Southernmost State. New York: Oxford University Press, 1939.

Florida Board of State Institutions. Soldiers of Florida. Tallahassee: 1903.

Gold, P. Daniel. History of Duval County, Florida. St. Augustine: The Record Company, 1928.

Heitman, Francis B. Historical Register and Dictionary of the United States Army. Washington, D.C.: U.S. Government Printing Office, 1903.

Historic Florida. Washington, D.C.: Works Progress Administration, 1933.

Inventory of the County Archives, No. 10. Clay County, The Florida Historical Records Survey. Jacksonville: Works Progress Administration, 1941.

Jones, William M. Fort Heileman, An Indian War Fort, Middleburg, Clay County, Florida. Jacksonville: 1969.

United States Department of the Interior  
National Park Service

National Register of Historic Places  
Inventory—Nomination Form

For NPS use only

received

date entered

Continuation sheet

Item number 9

Page 3

Larman, Charles. Adventures in the Wilds of the United States and American British Province. Philadelphia: 1856.

Revis, L.P. The Life and Military Services of General William Selby Harney. St. Louis: 1878.

Risch, Erna. Quartermaster Support of the Army -- A History of the Corps, 1775-1939. Washington, D.C.: Office of the Quartermaster General, Department of the Army.

Ryan, Thomas D. Clay County Florida: A Sketch of its Past. Jacksonville: Clay County Historical Commission, 1972.

Sprague, John T. The Origin, Progress, and Conclusion of the Florida War. New York: 1844.

NEWSPAPERS AND JOURNALS

Boyd, Mark F. "First American Road in Florida," Florida Historical Society Quarterly, XIV (October 1935 and January 1936), pp. 73-106, 139-192.

Clay County Mirror. April 1915.

Ewell, Frances A. "The Story of Middleburg," Jacksonville Historical Society Annual, (1933-1934), pp. 38-55.

Florida Times-Union. 1 January 1932. 10 December 1937. 5 May 1962.

Jacksonville Courier. 29 January 1836.

National Intelligencer. 25 November 1843.

**United States Department of the Interior  
National Park Service**

**National Register of Historic Places  
Inventory—Nomination Form**

For NPS use only  
received  
date entered

Continuation sheet

Item number 9

Page 4

OTHER SOURCES

East Point, Georgia. Federal Records Center. Record Group 60,  
Attorney General's Papers.

Gainesville, Florida. P.K. Yonge Library. "Ambrose Hart Collection."

Tallahassee, Florida. Department of State, Division of Historical  
Resources, Bureau of Historic Preservation. "Chalker Family  
File."

Washington, D.C. National Archives. Record Group No. 92. Records of  
the Quartermaster General's Office.

Washington, D.C. National Archives. Record Group No. 94. Records of  
the Adjutant General's Office.

United States Department of the Interior  
National Park Service

**National Register of Historic Places  
Continuation Sheet**

Photographs 1

Section number \_\_\_\_\_ Page \_\_\_\_\_

---

1. Clark-Chalker House
2. Middleburg, Florida
3. Larry and Mary Anna Gaudet, owners
4. circa 1986
5. Negatives held by Larry and Mary Anna Gaudet

Items 1-5 are the same for all photographs.

6. Photograph descriptions refer to the accompanying floor plan, and are given as if the house had a true north-south orientation.

- 1) Southwest view of house from left back
- 2) Northwest view of gazebo (storage shed) behind right of house
- 3) View of house from the south
- 4) View of closet door in room G, southeast bedroom, first floor
- 5) View of front of house and balcony on second floor, north elevation
- 6) View of front door, north elevation
- 7) View of stripped wall in room M, northwest bedroom, second floor
- 8) View of wall and ceiling in room H, northeast bedroom, first floor
- 9) Photo taken from hall I, central hall on first floor, facing north to show sidewalk in front of house
- 10) View of halls on first floor taken from hall I to hall D, facing south
- 11) View of fireplace on west wall of room F, living room, taken from south doorway

United States Department of the Interior  
National Park Service

**National Register of Historic Places  
Continuation Sheet**

Photographs 2  
Section number \_\_\_\_\_ Page \_\_\_\_\_

---

- 12) 3/4 view of west and south elevations
- 13) View of door of room F, living room, first floor
- 14) View of house taken from the northeast
- 15) View of original hall floors, showing doorway leading to rear hall D, first floor
- 16) View of east elevation taken from the southeast
- 17) View of left of house and old Masonic Lodge taken from the northwest. The lodge is not located on the property.
- 18) Facade, north elevation
- 19) View of door in room F, living room, first floor
- 20) View of window in room P, west bedroom, third floor
- 21) Northeast view of front yard, showing northwest corner of front porch

○ - Artesian Well

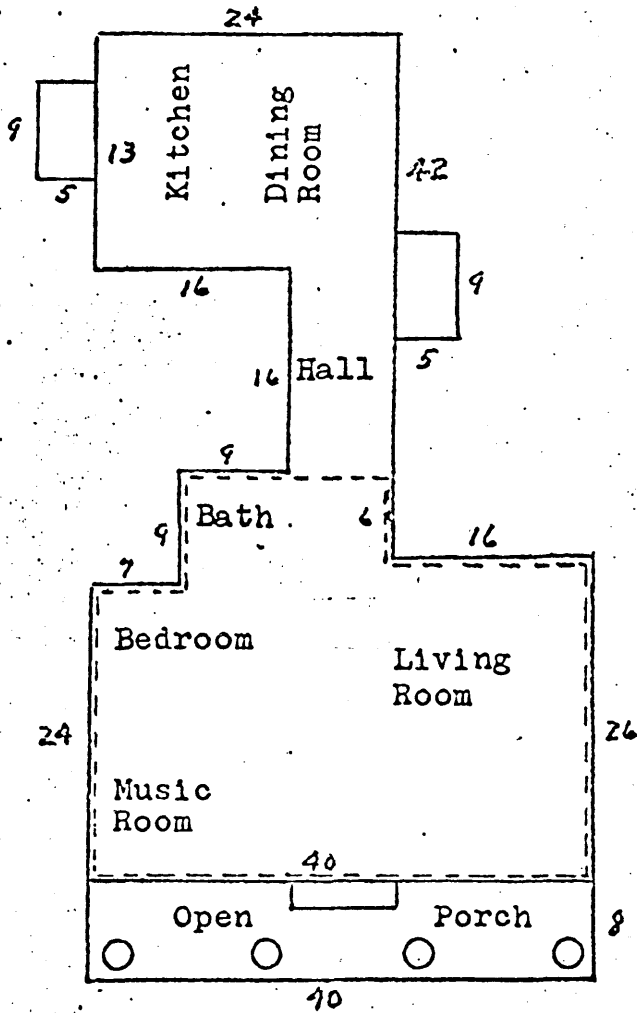
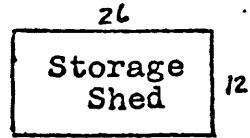
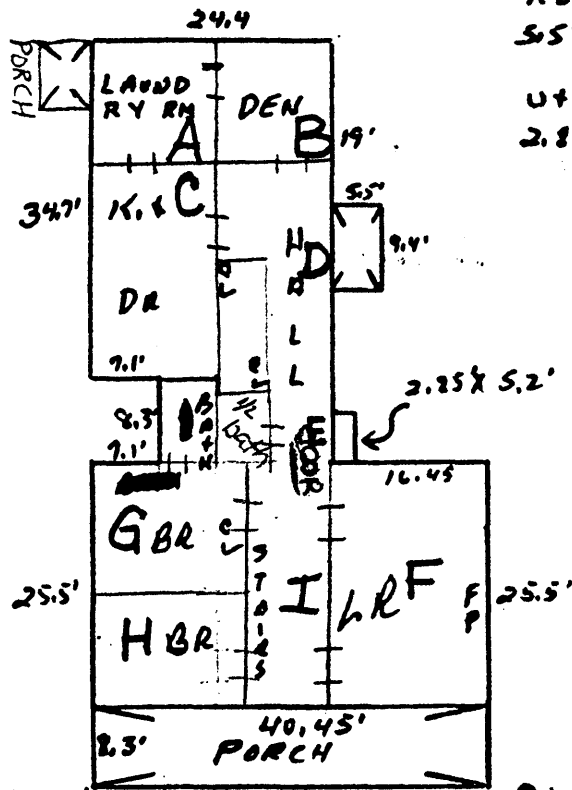

EXHIBIT A

Sketch of Main Improvement

Letters indicate rooms to accompany photos.

1st Floor



REAR Porch  
5.5' x 9.4' = 52 SF

Utility  
2.85' x 5.2' = 15 SF

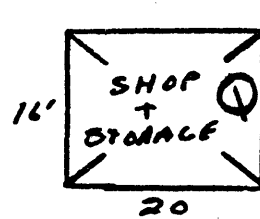

Gazebo behind right of house

STORAGE  
20 x 16 = 320 SF

2nd Floor

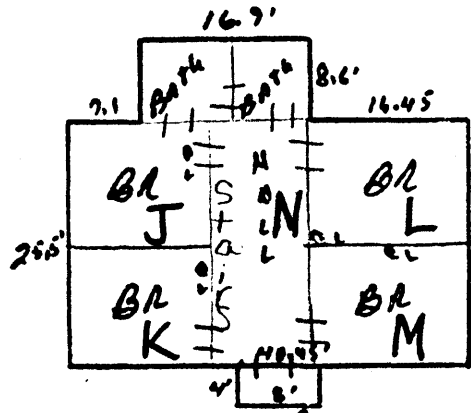

2nd FLR  
LIVING AREA  
40.45 x 25.5 = 1031.475  
16.9' x 8.3' = 140.27  
16.9' x 8.6 = 145.34

2nd FLR Living = 1177 SF  
Balcony 8' x 4' = 32 SF

3rd Floor

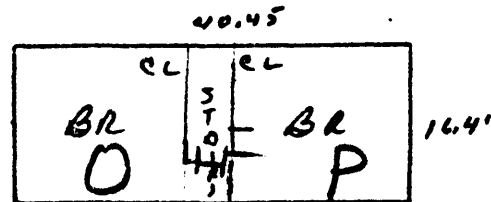

3rd FLR  
LIVING AREA  
40.45' x 16.4' = 663 SF  
2nd FLR = 1177  
1st FLR = 2018

TOTAL Living AREA = 3858

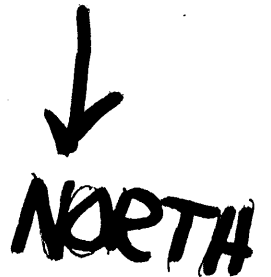

Right 1st FLR Living Area  
40.45' x 25.5' = 1031.475  
16.9' x 8.3' = 140.27  
24.4' x 34.7' = 846.68  
1st FLR Living = 2018 SF  
Porch 40.45' x 2.3' = 93.0 SF

# Locator map

NORTH  
↑

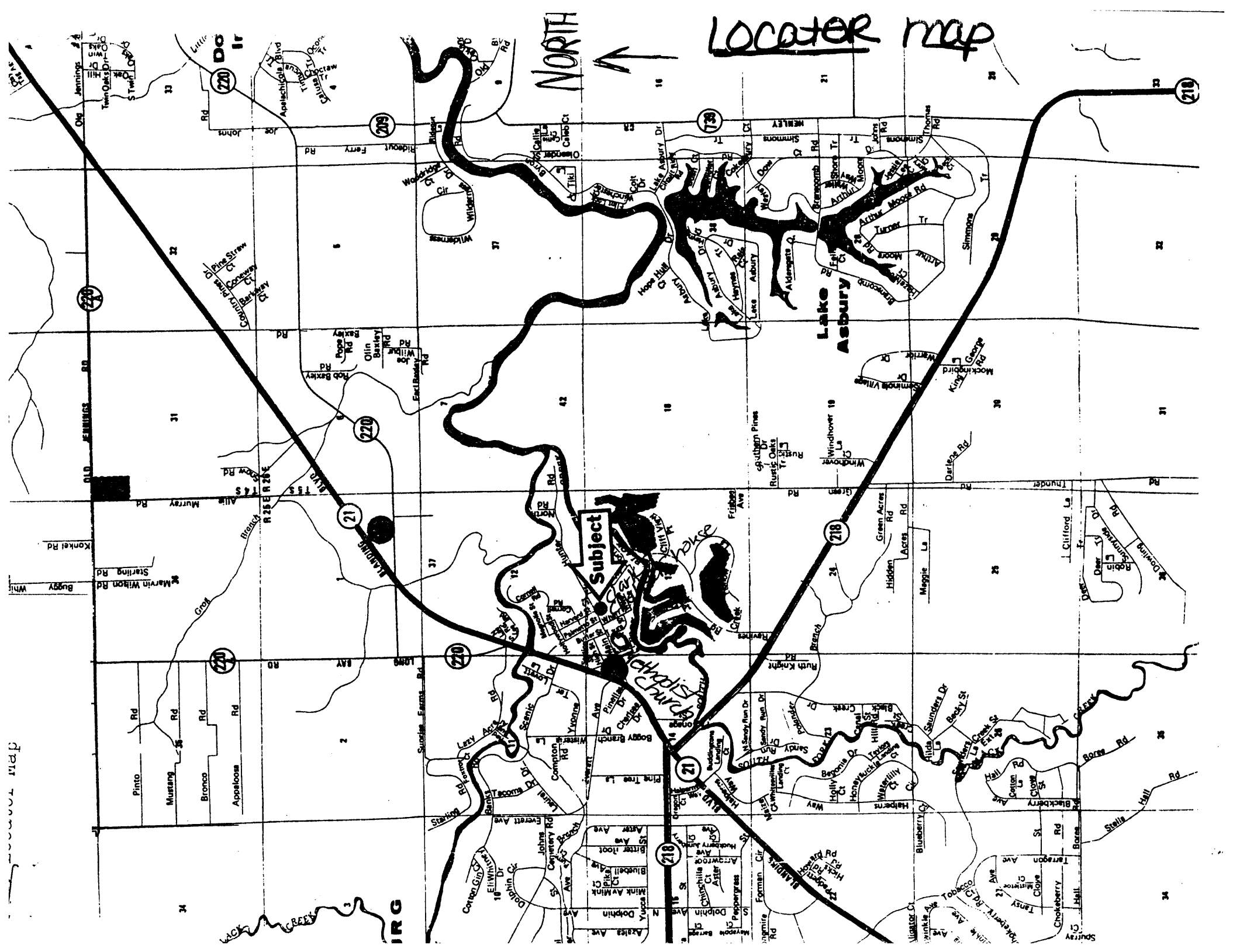

Subject

Lake Asbury

St. Philip's Church

Map not drawn

IRG



Sale No. 11/10/65

247.0

(UNPAVED)

HARVARD STREET

0.25E

Sale No. 1 11/29/66

0.25E

(PAVED)

PALMETTO STREET

0.25E

MIDDLEBAG GROCERY

242.0

50

MAIN STREET

314.16

113.4

49.2

LIFE ESTATE

160.1

SUBJECT PROPERTY

151.56

330'

442.2

151.56

(PAVED)

Post Office

50

THOMPSON STREET

40

LAURA STREET

175.0

(UNPAVED)

175.0

AURA ST.

EXCEPTION

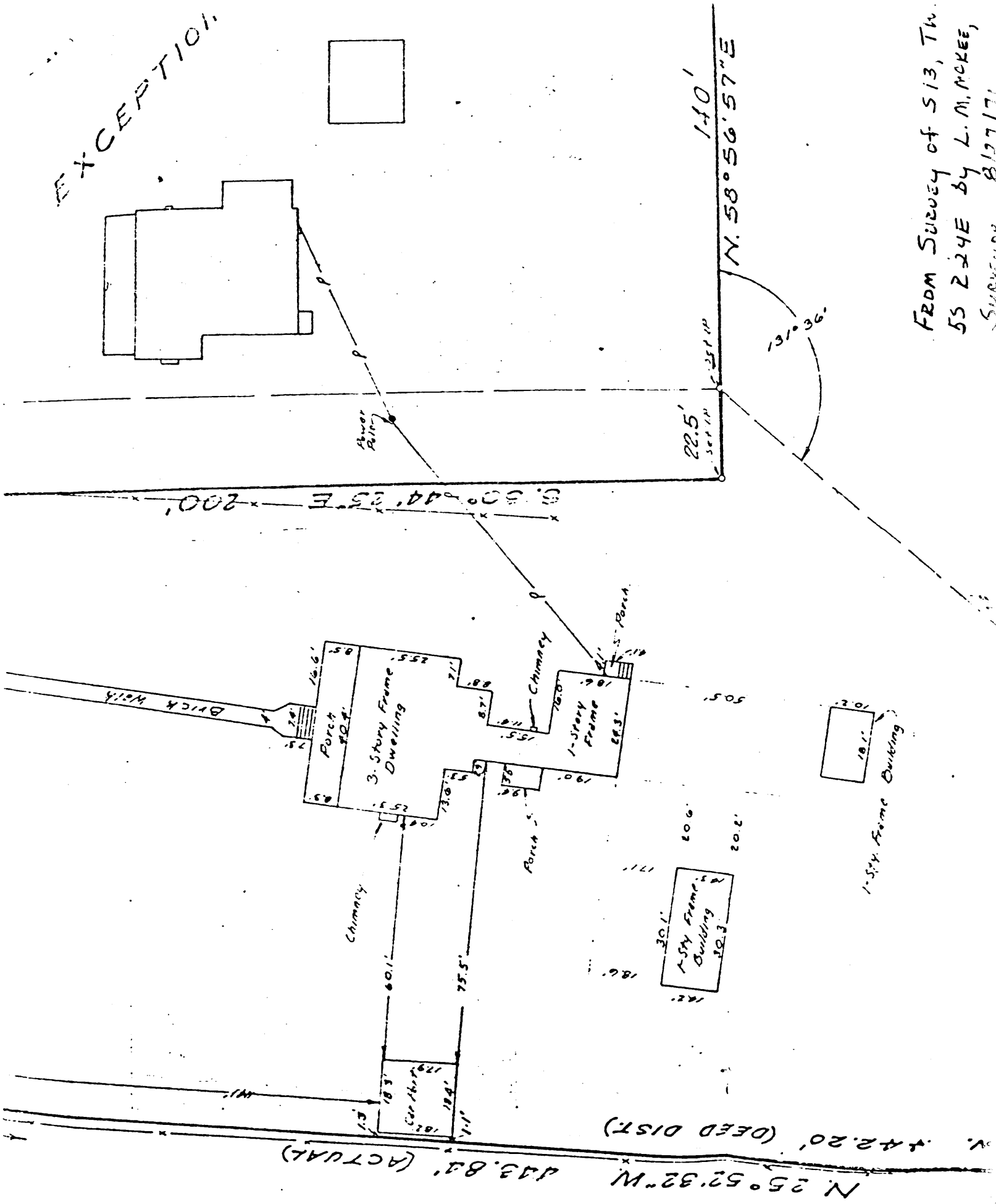

FROM SURVEY OF S13, TH.  
55 224E BY L.M. MCKEE,  
SURVEYOR 8/27/71