

INTRODUCTION AND CONTENTS

This Field Guide offers step-by-step instructions about how to observe, take field measurements, and create field notes and a short-form report about a historic site or structure to HABS standards. These guidelines are intended for use by those without professional experience and/or training in the production of drawings and the undertaking of field work. They address floor plans, elevations, and details to help develop basic note taking and delineation skills. Once these skills are mastered, recorders can refer to the HABS Guidelines for Measured Drawings to learn about site plans, sections, axonometric, and other more complex types of drawings. The Secondary House at Best Farm was selected as the case study because its relative simplicity encourages the development of basic skills and the establishment of realistic goals, while still offering thought-provoking interpretation. This guide is supplemented with a “Field Observations” and “Short-format Report” sections, as applied to the Secondary House, to assist the recorder with learning to “read” a building and to report on their findings. The Field Observations are applicable to both the preparation of informed drawings and to the analysis put forth in the accompanying historical report. The field analysis should be combined with preliminary research into primary and secondary sources for a concise report of a few pages in length. As with the drawings component, further investigations of the historical and architectural context of a site or structure can be expanded to produce a full outline report according to HABS Guidelines for Historical Reports.

The project was sponsored by the HABS office in coordination with Monocacy National Battlefield, Susan Trail, Superintendant, working with Joy Beasley, Cultural Resources Program Manager. The measured drawings guidelines, and the field notes and drawings, were produced by HABS architects Paul Davidson and Daniel De Sousa; and the Field Observations and short-format report by HABS historians Catherine Lavoie and Virginia Price.

Getting Started	3
Sketching Field Notes	4
Sketching Plans	5
Sketching Elevations	7
Measuring Plans	8
Measuring Elevations	12
Measuring Details	15
Field Observations	17
Appendix A: Short-Format Report	26
Appendix B: Full Scale Field Notes	34

The Team:

A measuring team should minimally consist of three people: two to take measurements and a third to record them. When drawing a large or complex structure, or when more people are involved the most efficient approach is to “divide and conquer” with multiple teams breaking up the work by floor, wing, or elevation. A supervisor, instructor or project leader should coordinate the multiple efforts to provide consistency and quality control.

Permission:

Be Safe:

Regardless of the size, type, or condition of the building, all participants on a HABS documentation project should adhere to the standards and regulations of the Occupational Safety and Health Administration (OSHA). This can be as simple as bringing along a flashlight or making sure to wear durable hiking shoes or steel-toed boots, or as demanding as wearing hard hats and respirators.

Necessary Equipment:

- Metal measuring tapes in 35' and 50' (or 100') lengths; ideally one tape for each team member (fiberglass and cloth tapes stretch over long distances and are therefore unreliable)
- 17" x 22" graph paper (bond), eight divisions per inch, non-reproducible grid
- Oversized clipboard
- Pencils (HB or harder) and erasers
- Molding comb/profile gauge (fine-toothed)
- Digital camera

Recommended Equipment:

- Red pens with archival ink (for writing dimensions)
- Large 30°-60°-90° drafting triangle
- Flashlight / headlamps
- Plumb bob
- Line level and string
- Ladders
- Directional compass





General Rules:

Field sketches, dimensions, and notes are drawn on archival quality (bond) graph paper with eight divisions per inch, with grid lines printed in non-reproducible blue. Only one side of the paper should be used. HABS typically uses 17" x 22" sheets, which can then be folded into 8-1/2" X 11" in order to fit into standard HABS field note covers. All field notes are transmitted to the Library of Congress for future reference.

Legibility is important. Everyone on a team should be able to read everyone else's field notes. Sketches should be drawn large enough to accommodate long strings of dimensions neatly. This may require complex elements be simplified or the scale exaggerated so that there will be enough room to write dimensions legibly. Extremely complicated spaces, such as staircases and areas with built-in cabinetry, may have to be drawn on a separate field note at a larger scale than the rest of the plan and should be clearly referenced back to the master plan.

Details, such as door and window jambs, should be sketched separately at larger scale (see: Details). For large or complicated buildings, it may be necessary to lay out one drawing (a plan or elevation, for example) over multiple sheets of field notes. Be careful to locate your match lines logically, and make sure each sheet is clearly referenced to the others.

Each field note must be labeled in the lower right corner with the name of the building or structure, the identification of the sketch, the name of the delineator, the date, and the HABS number (if it has already been assigned). For example:

Best Farm, Secondary House
Second Floor Plan
Daniel J. De Sousa
September 2010
HABS No. MD-1171-A

Divide the tasks of sketching and field-noting a building by floor, elevation, or, if a large building, by wing. For the sake of consistency and in order to avoid repetition, assign one team member to a particular set of details (i.e., doors, windows, fireplaces, staircases, etc.)

SKETCHING PLANS

When you are ready to sketch a building's plan, a good way to begin is by drawing the exterior shell first. There are two reasons for this: First, by beginning with the outside you can be sure that your drawing fits on the sheet, with enough room along the edges for dimensions. (Or, if your building is large, starting this way can help you determine if you need more than one sheet.) If you begin by field-sketching from the inside out, you may find that you drew things too large and part of the building does not fit on the sheet, or that there is not enough room between the outside wall and the edge of the paper, forcing you to write outside dimensions inside (usually illegibly). Second, if you're fairly accurate about the location of doors and windows when drawing the shell, it makes it easy to place rooms when you sketch the inside.

Start by walking around the outside of the building to get a feel for the general shape. Is it a single rectangular block? Is it divided into bays? Does it have an ell? Wings? Irregular additions? Porches or exterior stairs? Remember to think about the location of windows and doors.

As you are walking, think about your cut-line. Plans are typically drawn and measured at approximately 4'-0" above the floor. However, the height at which measurement strings are taken may jog to pick up important features. Think about what and where you will measure, and begin to pay attention to things below the cut-line that you may not normally notice. Window sills: do they protrude, or are they flush with the wall? Is there a belt course? A water table? Hand rails? These things should appear in your sketch.

Once you know the basic shape of the building, see how it would best fit on your paper. Using the grid, lightly block out where you think the building's corners should be (and don't forget to mark porches or stairs!). Make sure to leave at least an inch and a half all the way around for writing exterior dimensions.

Now walk around the building again, but this time take your clipboard and sketch the outline as you go, being mindful of where you marked your corners.

In order to maintain a decent sense of scale, it can be helpful to create rough units out of parts of the building. Windows are handy for this, since they tend to be uniform and a size that is easily understood. And since they are present on both the outside and the inside, you can continue using them as a unit of measure when you begin to lay out the rooms on the plan.

Tip: First decide how many squares long a typical window will be on your field note, and then use this relationship to estimate longer and shorter distances. ("Hmm, this wall looks about nine windows long; if a window is six squares, then the wall should be 54 squares, or 6.75 inches.") You can estimate using larger or smaller parts, too, and even relate them back to your basic unit, the window. Perhaps a building's entire length is five times the length of its ell (which is itself three windows long). Or maybe a column or chimney block is about three bricks wide (where said brick might be about one-sixth of a window).

Tip: For estimating small distances, if you hold your middle and ring fingers toward your palm with your thumb ("throwing the horns"), the distance between your extended index and pinky fingers should be about four inches, give or take.

Tip: For window and door frames, it is not necessary to draw every ogee, flute, and quarter-round return, but you should at least indicate the jambs and where the frame begins and ends so that you have places to mark dimensions later.

Remember that your field note will never be perfectly proportional, and as mentioned in the General Rules section, there will be times when you should simplify or exaggerate parts of the sketch so that it is clearer and easier to dimension.

The process for drawing the interior of the plan is similar. Begin by walking through the building and seeing how the different rooms relate to each other and to the outline you just drew. Take note of where the cut line should be, and what you will see below it. Plans are typically measured through the lower sash of double-hung windows and above chair rails, but cut lines are usually dropped to show fireplace openings at their maximum depth. Remember to look for sills, chair rails, baseboards, thresholds, plinth blocks at the bottom of doorframes, etc.

Certain kinds of overhead lines should be shown, too, so remember to look up! These are drawn on the plan using a dash-dot line, and include ceiling hatches, stair openings, beams, joists (if exposed), arches and vaulting or other indications of a change in ceiling height. Things that are typically ignored include dropped ceilings, plumbing and mechanical systems. Features that are hidden or missing should be indicated by a dashed line. For example, a missing door should be drawn with its swing (if known), with a dashed line.

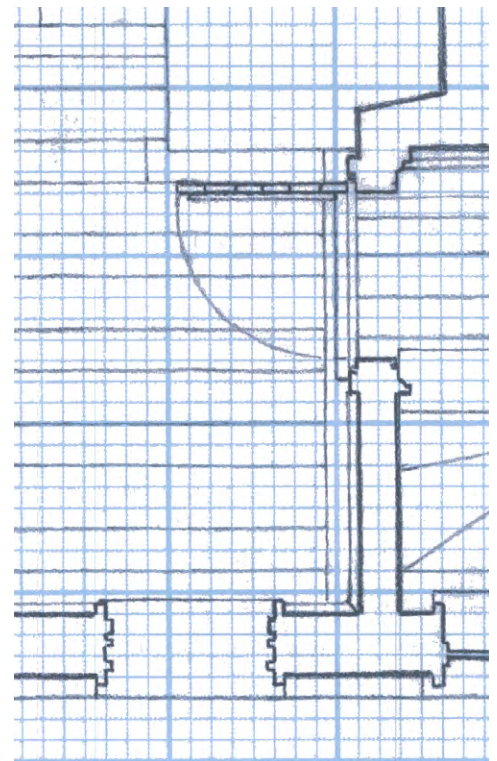

Level of detail typically required for a floor plan field note.

Beginning with areas that have windows or doors to the outside, start sketching, keeping in mind proportions and your rough unit of measure (if you used one).

Tip: In the sketch phase, it is important to mind your line weights. Make the lines of the walls and anything else being cut through darkest. Things below the cut line, such as chair rails and baseboards, should be drawn more lightly.

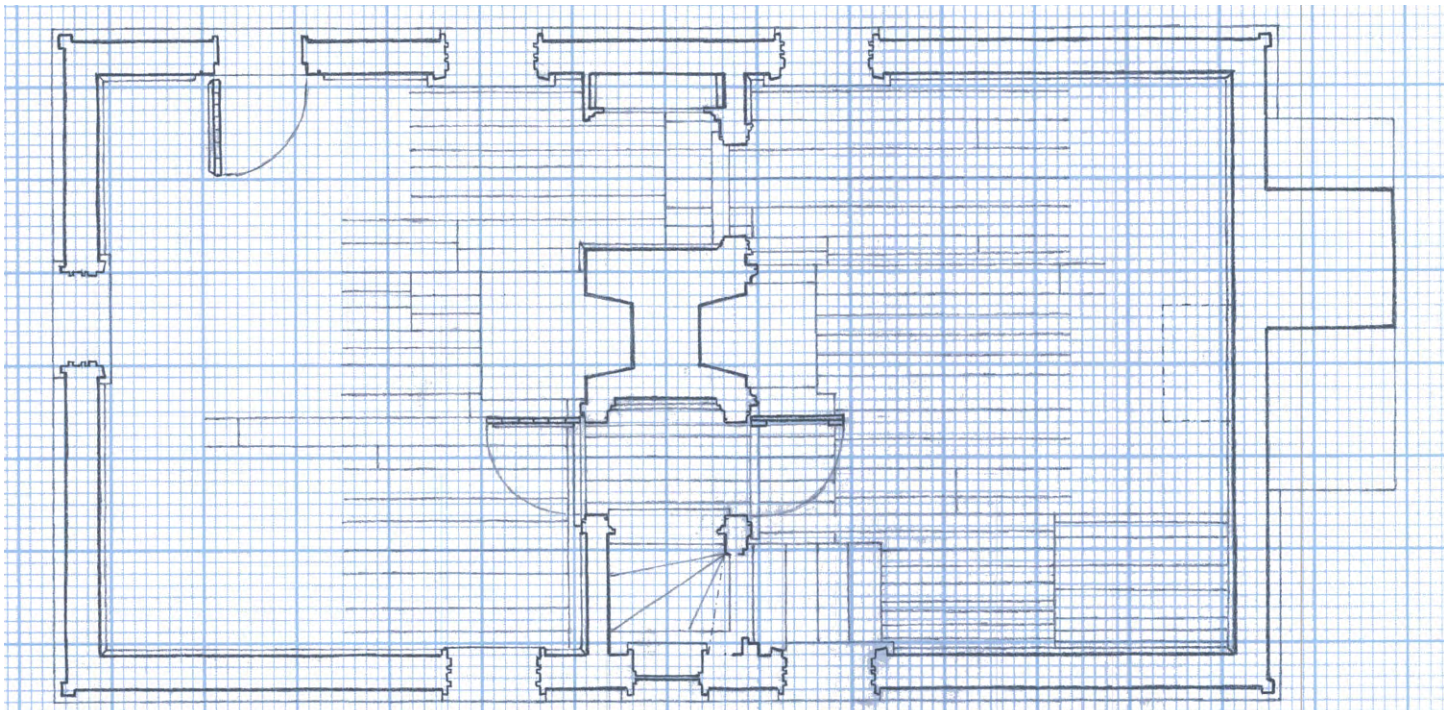

Completed sketch of the first floor plan, Secondary House

SKETCHING ELEVATIONS

Sketching elevations is similar to drawing the plan. When sketching, it is useful to exaggerate the scale of complicated features, like windows and doors, as they require the most dimensions later. It is not necessary to draw every line of a profile in elevation, only the outermost edge needs to be drawn as this is the edge that will be measured (see Measuring Elevations). A profile of the molding is a better way of capturing the remaining edges (see Measuring Details).



North Entry, Farm House

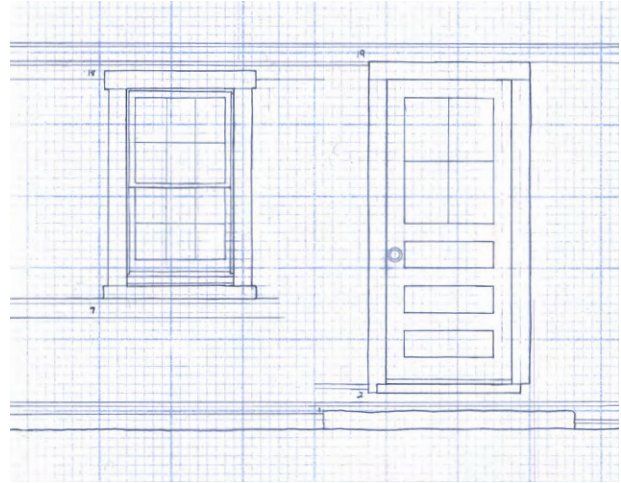

Field Sketch

It usually is not necessary to draw each brick course or row of siding, unless they are determined to be uneven. Instead, draw and number the courses that line up with significant features of the elevation (such as window sills and lintels), and divide the courses evenly when you are creating the final drawing. Also, remember to count and note the rows of shingles on the roof.

Pay particular attention to eave and soffit details, as they provide the foundation for determining the slope of the roof (see: Measuring). Sometimes these need to be drawn separately at a larger scale as a detail. Gutters and downspouts are typically omitted from elevation drawings unless the gutters are built into the eaves.



South Elevation, Secondary House

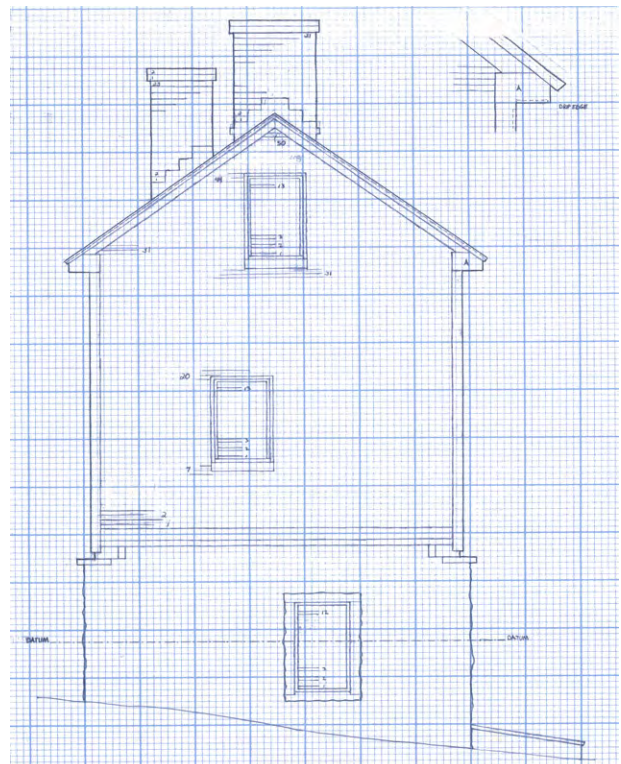

Field Sketch

MEASURING PLANS

Orient the plan so the principal entrance is at the bottom of the sheet. This is how the finished drawing will appear, so you might as well get used to thinking of the building this way now. Dimensions can be written in red pen with archival ink. Take measurements along walls in one continuous string whenever possible. Measuring a wall in pieces leads to accumulated error over long distances. Dimensions are taken to the nearest 1/8th of an inch. HABS records each measurement with three numbers, separated by periods, representing feet, inches, and eighths of an inch. This eliminates fraction lines and provides greater clarity. For example:

Three-feet, one and one quarter inch = 3'-1 1/4" = 3.1.2

Measurements should be written perpendicular to the dimension line and next to the appropriate tick mark, rather than between two tick marks. It is important to mark the zero on the field note for each dimension string.

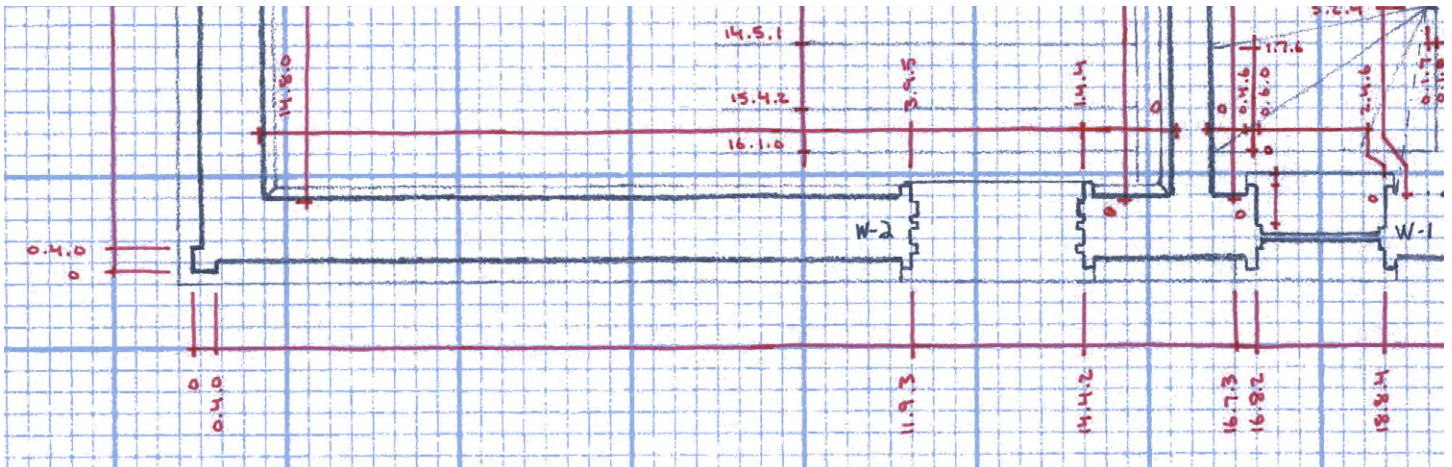

First floor plan, Secondary House

Ideally, a measuring team should consist of three people: one person to hold “zero”, one person to pull the tape and call out dimensions, and one person to record them on the field note. The recorder should be the person who drew the field note being measured.

The person recording might find it helpful to mark out dimension lines on the plan before the team begins measuring. As you are doing this, keep in mind that the floor plan field note is intended to locate significant building features. Door and window openings should be measured to the inside of the jamb.

When you are ready to begin measuring, place the zero end of the tape in the most convenient corner and pull the tape to the first feature. Make sure the tape is taut and, where possible, chest height.



Measuring the first floor plan, Secondary House



Measuring the second floor plan, Secondary House.

Tip: The recorder can help make sure the tape is level, and over long strings can hold the tape in the center to prevent sagging. Resting the tape on building projections such as window sills and hardware can help to prevent the tape from sagging, provided they line up with the plan's cut line.

When there are numerous obstructions along a wall (pipes, conduits, ducts), do your best to keep the tape as close to the wall as possible by threading it behind these features if you can. If this is impossible, then stand the tape out from the obstructions to get an overall measurement, and then measure any openings or other features from the most convenient zero.

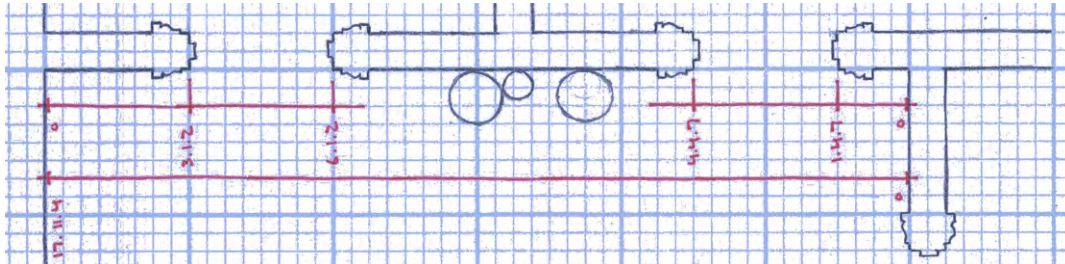

Tip: If the flat hook-end of a standard 35' tape measure does not fit through the gap behind a barrier, try using a 50 or 100' tape, which usually has a much thinner end. The zero on a tape measure with a folding hook is at the end of the hook not where it attaches to the tape.



Tip: A 50' tape can also be used to take circumferences of columns and other circular objects. To determine the entasis of round columns in elevation take the circumference at regular vertical intervals.

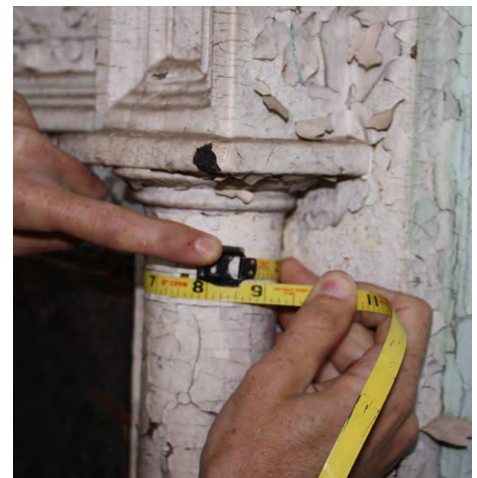
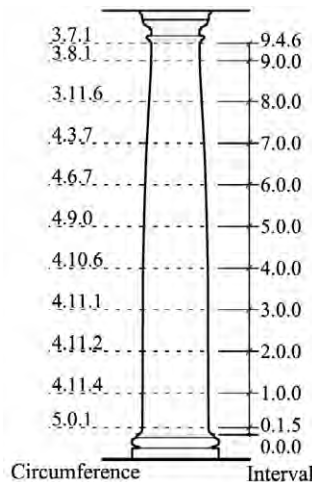

Tip: Triangles are helpful in measuring edges that are set back from the line of the tape.

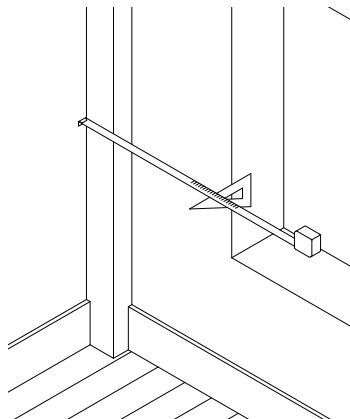

Wherever possible, take confirming dimensions from one room to another through door openings. These will help determine wall thicknesses and link the rooms together in plan later on. If a room is clearly out of square--that is, if opposite walls are not equal in length--then it can be helpful to take diagonal measurements from corner to corner. If you are taking many diagonals it is better to label them with lettered points and create a list rather than draw the dimension strings.

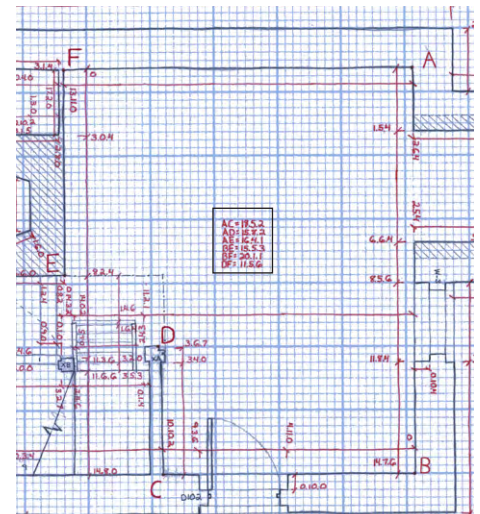
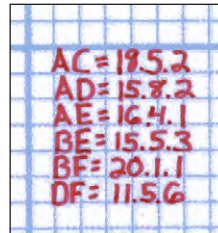

Ground floor plan with diagonals, Secondary House

When measuring stairs, measure both the first step and the highest step possible from the same zero. Then divide evenly by the number of treads. It is not necessary to measure individual steps unless they are obviously irregular. Always measure to the nosing and not to the riser underneath. Be sure to locate any newel posts and hand rails.



When measuring fireplaces, be sure to first locate the opening of the fireplace in a general string of dimensions. Then measure the perimeter of the firebox at its deepest point. Locate and measure the hearth in relation to the firebox opening. Remember to measure the mantel.



When measuring flooring that is determined to be regular, the number of floorboards or tiles can be counted and then evenly spaced in the final drawing. A vignette is generally sufficient for most buildings. If the flooring is irregular, each floorboard or tile should be measured on strings separate from those used to measure the walls. These dimension strings generally are taken from the baseboard and should be noted as such.

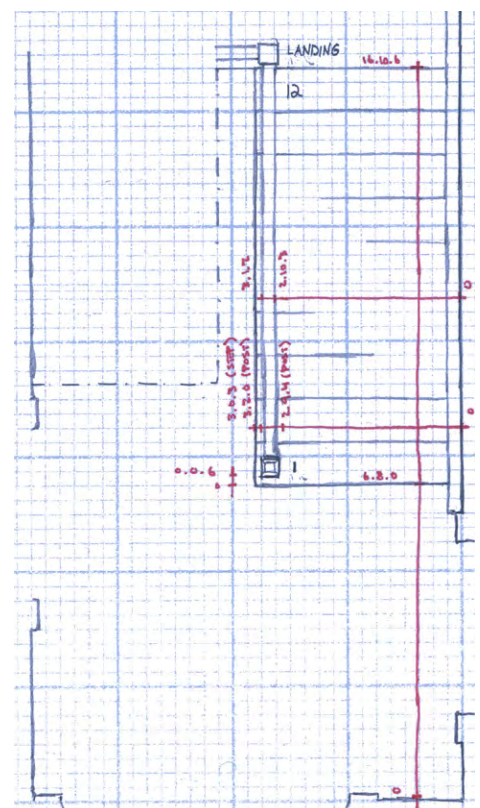

Typical first floor stair dimensions, Farm House

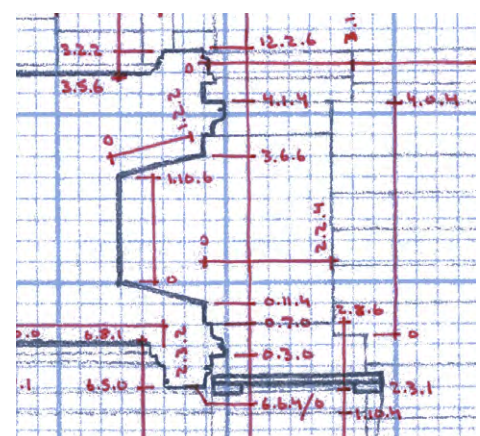

Fireplace dimensions, Secondary House

Using a plumb bob: A plumb bob can be used to tie ceiling or floor features into a string of dimensions taken at chest height, such as the edge of a stair tread or a ceiling hatch. After unstringing the plumb bob, allow it to come to a complete rest. If you are measuring up from the floor (figure 1), make sure the point is aligned with the feature you are measuring. If you are measuring down from the ceiling (figure 2), hold the string of the plumb bob on the edge to be measured.

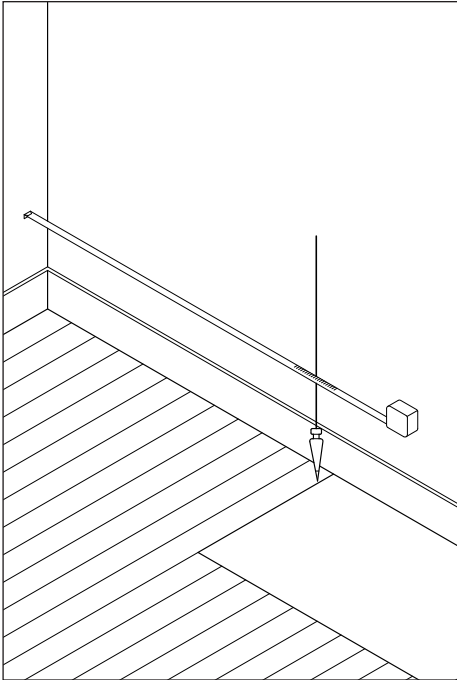

Figure 1

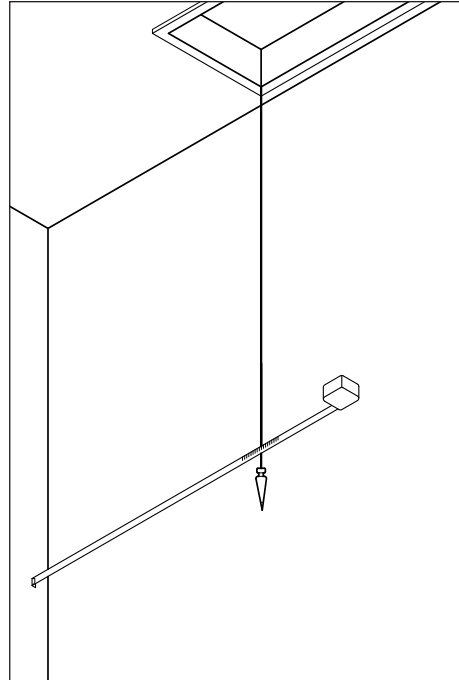
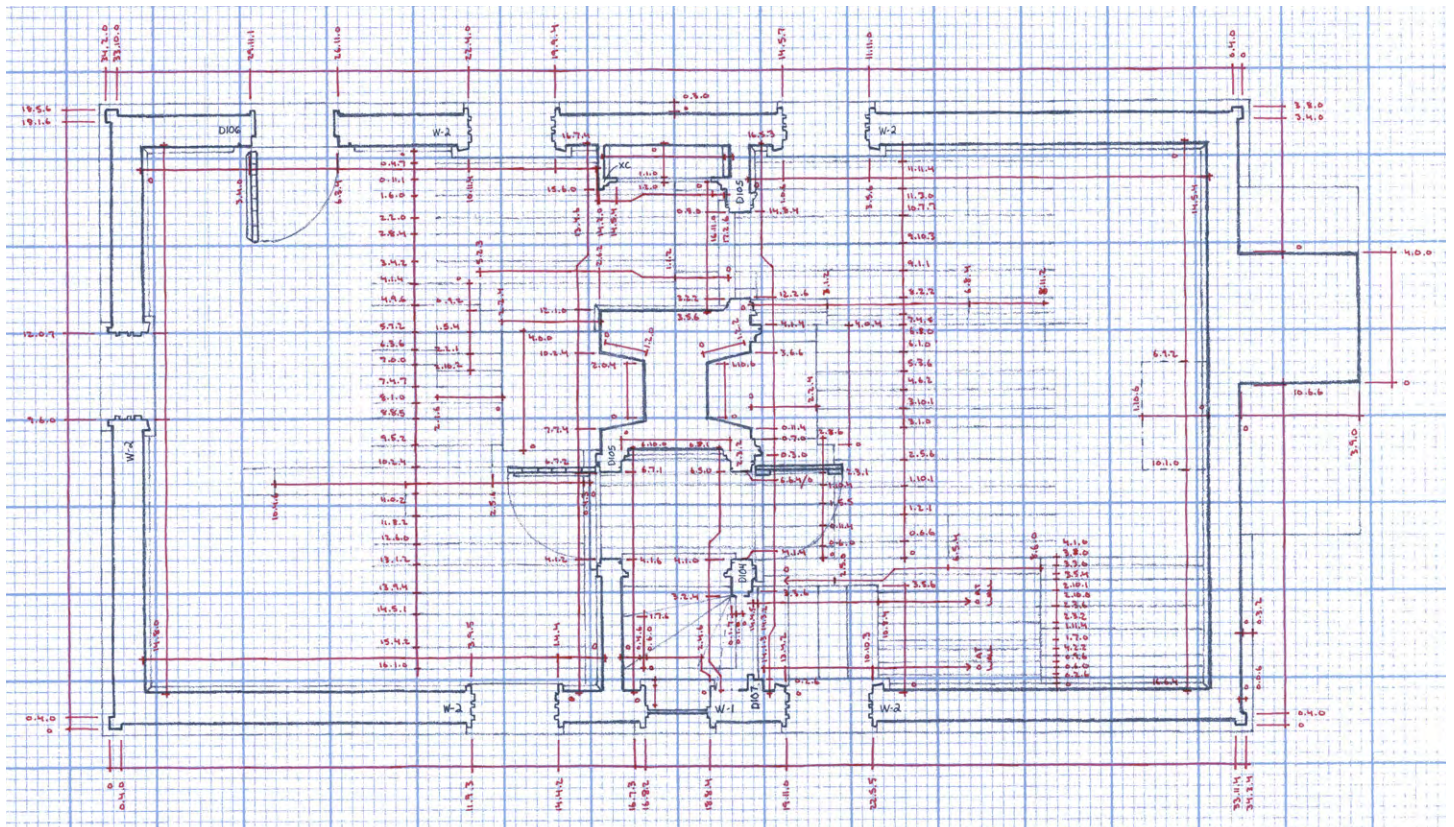

Figure 2



Using a plumb bob to locate the first floor newel post, Farm House



Dimensioned field note, first floor plan, Secondary House

MEASURING ELEVATIONS

Elevations are measured with continuous vertical dimension strings. It is important that all vertical strings be located in reference to a horizontal datum. The datum may be an actual feature of the structure, such as a horizontal brick course or the bottom edge of a siding board, as long as the feature is consistently level around the entire building. Otherwise, it may be necessary to create a datum (a horizontal reference) using a string and line level. Dimensions that tie into the datum are generally taken at the corners of the building and at each opening. These define the overall geometry of the building. Remember to measure to grade.

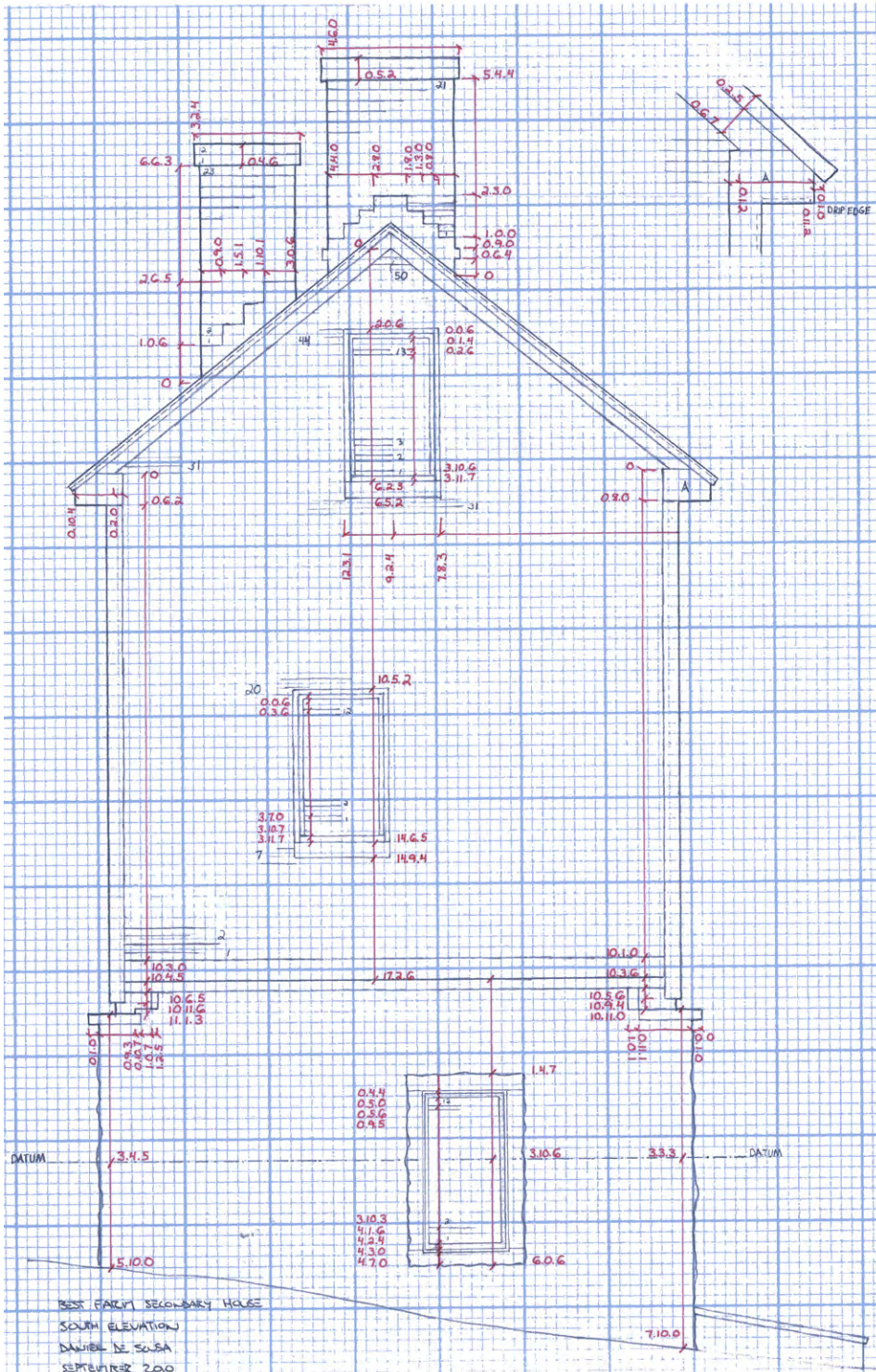

Dimensioned field note, with Datum North Elevation, Secondary House

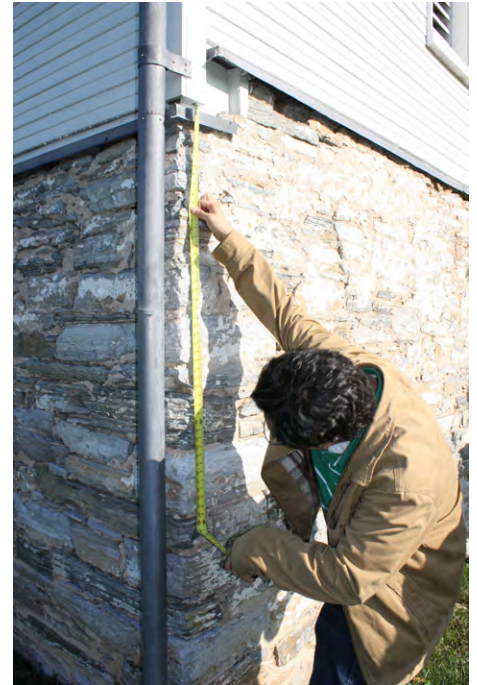

Measuring to the datum, Secondary House



Chimney dimensions, Secondary House

Using a line level: Decide where you would like to cast the datum; often this is done along a sill, though in the absence of any convenient features it may be arbitrary. The point can be marked with a pencil or tape according to building material. On your sketch, draw in the datum with a dash-dot line.

It takes three people to use a line level. The first person holds one end of the string at the mark, while the second person runs the string to the first door or window, pulling it taut. The third person centers the line level between the two ends and determines if any vertical adjustments are needed by the second person. Once the string is level, draw a second mark at the door or window frame and take any vertical dimensions to it.



Creating a datum using a line level, Secondary House

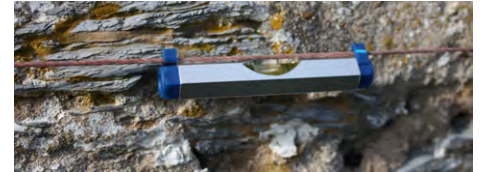

Marking the datum.

When measuring doors and windows make sure that the profile at the head of door or window is identical to the profile in plan, if not additional measurements may be required. At this point, only the outermost edge of the profile for the window or door needs to be measured.

Windows must be measured with the sashes completely closed so the meeting rails are in line with each other. There are generally three sets of dimensions that are required to measure a window for an exterior elevation. The first set of dimensions places the window opening in relation to the datum (Photo 1), the second set locates the upper sash (Photo 2) and finally the lower sash is measured (Photo 3).



Photo 1, Farm House

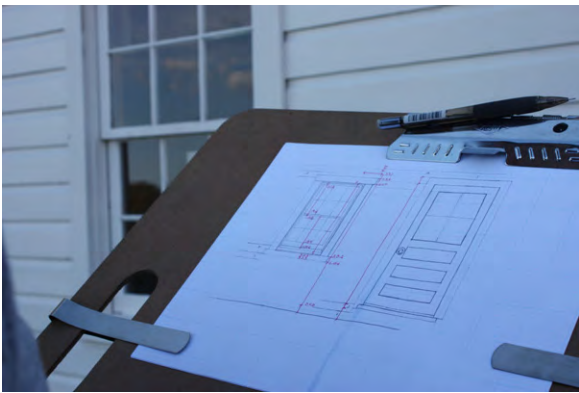

Photo 2

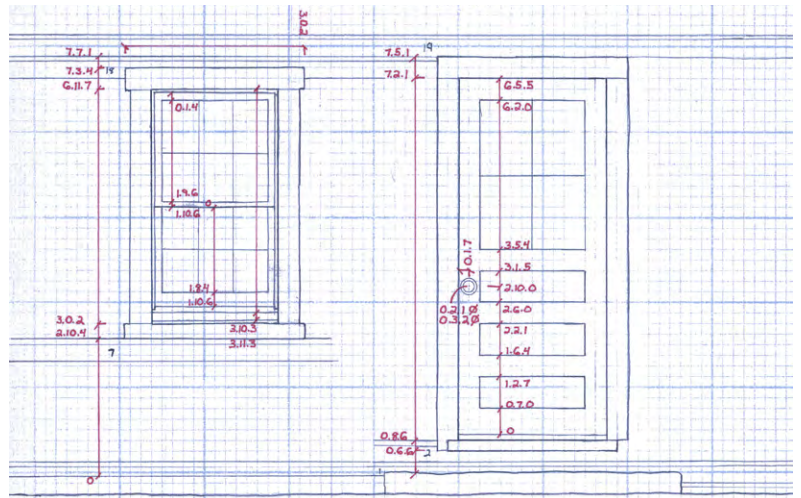

Photo 3

When measuring doors, do not measure them independently of the frame. Always place zero either at the top of the frame or at the threshold. It usually takes two sets of dimensions to measure a door. The first set locates the door opening in relation to the datum and the second set picks up door panels and hardware. Remember to take the panel profile of the door if it was not taken for plan details (see Measuring Details).



Dimensioned door and window field note, Farm House



Measuring Roofs:

Generally speaking a laser transit is the most accurate way to obtain roof measurements particularly on hipped roofs. The techniques described below for measuring roofs are based on the assumption that a laser transit is unavailable for measurement data.

The slope of the roof can be determined by measurements taken at the gable end. It is best to visualize the gable end as a triangle where the three corners need to be located horizontally and vertically in order for the elevation to be drawn. If the roof peak is off center, a plumb bob can be used to locate the peak horizontally.

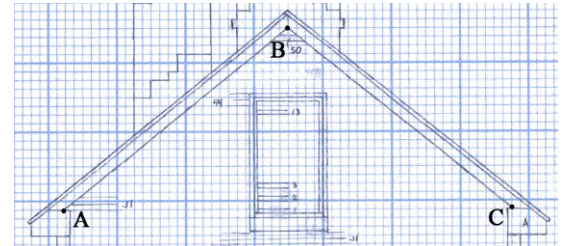

If the roof is hipped, the roof slope and height will be more difficult to obtain. A measurement along the slope of the roof from shingle edge to the ridge as well as a horizontal length of the ridge can provide some accuracy (Figure 1). If the roof rafters are exposed in an attic space, measuring them in section may enhance the accuracy of the exterior roof dimensions as it will be possible to obtain the rise and run of the roof over a greater distance (Figure 2). Dormers, chimney and other relevant roof information should be measured horizontally from the roof edge as well as vertically.

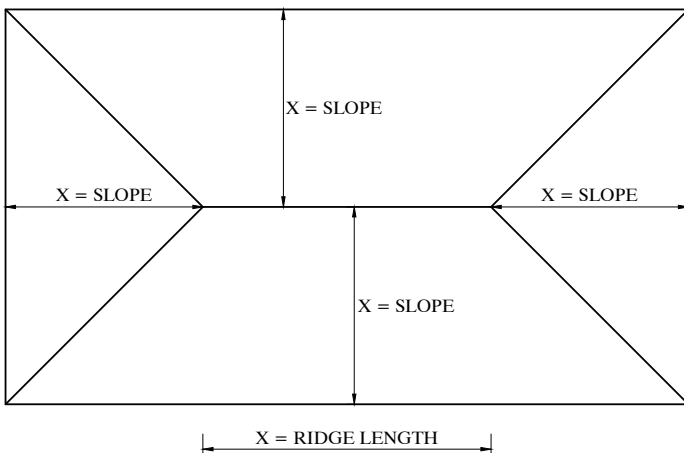

Figure 1, Roof plan

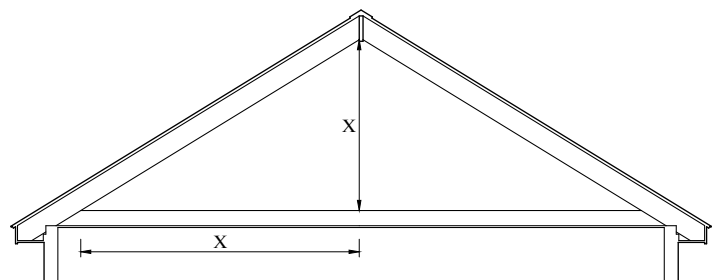

Figure 2, Roof section

MEASURING DETAILS

Window and door details should be keyed to the plan. It is helpful to use a W or D prefix; for example, the first window that you detail would be labeled W1, the first door D1. As you go around the plan, doors and windows that repeat should have the same label.

When capturing a door or window detail for the plan, it is best if you draw all profiles relating to that door or window together on the same sheet. For example, a door detail set should contain profiles of the door frame, the door panels (if any), and the threshold. A window detail set should contain profiles of the window frame, the sash and muntins (if any), and the interior and exterior sills. This prevents confusion over what has and has not been detailed.

Be sure to capture the overall dimensions of a door (thickness and width) and locate any panels. Windows should be measured for the overall width of the sash; if the lights are regularly spaced it is not necessary to measure to each muntin.

Other details that you should capture include any trim elements (crown moldings, picture rails, chair rails, baseboards, wall paneling, wainscot, etc.). These details should also be keyed to the plan.

A molding comb or profile gauge is the best bet for recording moldings like door and window frames, balusters, hand rails, baseboards, and chair rails. To use a profile gauge, first straighten it by pressing it against a flat surface so all of the pins extend out of one side in a neat row. Then, position it against the surface you want to capture, and apply steady pressure. Do your best to make sure the pins don't slide out of alignment and bunch in a crevice or a corner; this can be tricky on smooth surfaces like glass or over-painted wood, and may require you to occasionally pull and straighten pins while you're taking the profile.



Once you have the outline captured, place the comb flat against a sheet of field note paper to trace it, making sure the profile is aligned with the grid. Profiles larger than the comb should be taken with multiple, overlapping impressions.



Lightly trace the profile and remove the comb. You will notice that the profile is not as defined as it should be due to layers of paint coupled with the limitations of the comb. That is why it is important to refine the profile with a heavier line making sure to sharpen edges and smooth the curves. This is best done in the field as it can be compared against the actual profile.

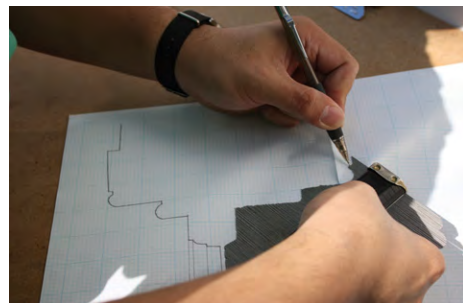
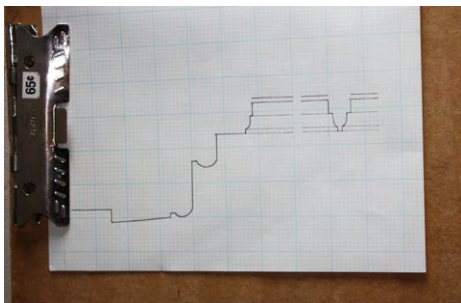

Tip: Record profiles from areas that are the least worn or painted.

Tip: To save space on a sheet, flat sections of large profiles can be shortened, as long as you provide the actual dimension.

Tip: Be sure to trace along the side of the comb that you recorded the profile! If the pins skewed slightly while you were taking the profile and you trace the wrong side of the comb, the sketch may come out distorted.

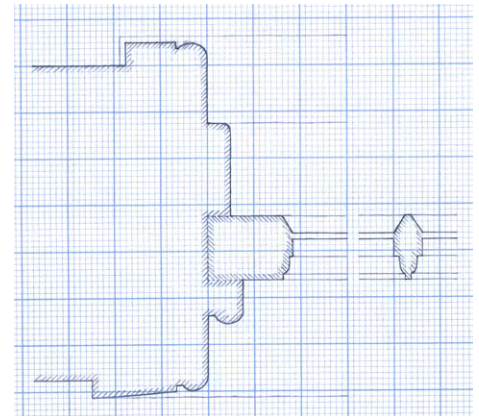

Window profile, Farm House

Tip: You will begin to lose pins from your comb after a while, either because they fall out or because they bend while you are taking a profile. This is a fact of profile comb life, and it usually does not detract from the comb's usefulness until a great many have gone missing.

For some flat details, such as “gingerbread” decoration, it may be easier to create a rubbing by laying a piece of paper on it and sketching over any defined edges with the side of a pencil.



Stair bracket rubbing, Farm House

Digital photography can also be useful in capturing details that a profile comb can not. Be sure to take overall dimensions of the detail you are photographing so that the image can be scaled correctly later. Alternately, you can use a reference scale (as pictured below right).

To reduce distortion when taking a photo of a detail:

- Make sure the camera is held parallel to the surface.
- Center the detail and leave ample room toward the edges as this is where the most distortion occurs.
- Stand away from the detail and zoom in so that you are not using lowest end of the camera's magnification or the wide-angle portion of the lens.



Detail photography using a scale square, Farm House



Detail photograph, Farm House

FIELD OBSERVATIONS

Note: While in the field taking measurements, it is a good idea to write a basic description of the structure, and to record your observations. It is through just such an exercise that characteristic elements are identified, patterns of use determined, and discrepancies in construction that hint at changes over time are observed. Keep in mind that sometimes the significance of various features are not readily apparent now, but may be revealed through later insight or research, so take note of them. It may be helpful to have a checklist of the various building elements to ensure that you have considered them all. (For a checklist see HABS Historian's Guidelines, Outline At-a-Glance.)

Exterior:

When walking around the Secondary House, first take notice of the general shape, fenestration pattern, materials, chimney placement, and detail elements, all of which are clues to its period of development and stylistic origins and to its use and change over time (Fig. 1-5).

Its small, rectangular, three-bay-by-one-bay configuration and center chimney suggest a simple two-cell structure (two adjoining rooms on each floor).

Likewise, the center chimney further suggests that the two rooms share a common wall, on each side of which is located a fireplace for heat, thus containing no intervening space (hall) between.

The fenestration of the west front elevation is unbalanced, and it appears that a bay has been removed from the northern end. It is also clear that a porch or stoop(s) was once present, as the door is no longer accessible. Check for clues as to their former existence, looking for elements such as post holes or footings in the ground or porch roof supports in the eaves (Fig. 3).

Notice the high, raised basement which is unusual for this rural, more northern setting. Coupled with the large stone end chimney it is possible that this was used as a domestic service space. Note the traces of whitewash on the (randomly laid) stone (Fig. 4).



Figure 1



Figure 2



Figure 3



Figure 4



Figure 5

The house is sided in wood, although the depth of the bays (best visible at the doorway on the first floor due to the installation of the ventilation panels in the window openings) hints at a different form of construction and, in fact, the building above the stone foundation is log (Figure #6-9).

Unfortunately, the windows have been removed and ventilation panels inserted in their place to “mothball” the house, but it is still worth noting their location and size (while looking for clues as to the type and style of the former windows in the existing framing). What is the function of the small portal cut into the center of the rear elevation (Fig. 5 & 10)?

Likewise, note the doors and doorways (although largely rebuilt). Why are the first floor and the ground level doorways each on one side only? Is the lack of ground level doorways to the west front evidence that a porch or gallery once appeared along the front that would have blocked access to that level? Is it to orient the kitchen functions towards the fields and away from the main house?

The rear bulkhead entry indicates a sub-basement, likely for (food) storage (or later installation of utilities).

Based on the small size, humble materials (rubble stone and log) and stylistic elements (or lack thereof), it is likely that the original occupant was an early settler to this area, someone of limited means, or that it was intended for use by a tenant, overseer, laborer(s) or slave(s). In fact, similarly built duplex building forms are common to slave quarters. The large stone chimney at the north end wall suggests that this building may also have served in some capacity as a farm dependency for use in food preparation or other form of domestic service.

Because this is the “Secondary House” it is worth noting its relationship to the main house and to the rest of the farm, noting that the front faces the main house, and that it is located between it and the fields. In fact, in these fields, evidence exists of a row of slave quarters, indicating the Secondary House’s placement within a social hierarchy with the main house to the west and the slave quarters to the east (Fig. 2).



Figure 6



Figure 7



Figure 3



Figure 9



Figure 10

Interior, Basement (Ground) Level:

Currently, the secondary house is entered via the raised basement or ground level. Entering from the northern doorway, the oversized fireplace/hearth in this room suggests use as a kitchen, or at least some form of domestic use associated with food preparation, laundry, etc. (Fig. 11 & 12).

Despite the deteriorated state—including missing flooring and falling plaster—clues about interior treatment can be read. On the rear wall, variations in paint color between the top and bottom portions, along with nailing blocks in the upper portion, indicate that wainscoting and/or cabinets were once situated here. The location of the missing floor can also be read in the paint marks and placement of extant beams.

The beams or floor joists of the first floor can also be viewed overhead, due to missing ceiling plaster, providing an opportunity to observe the construction method/technology that give clues as to the age of the structure. The joists are hewn rather than sawn, indicating that the house was built before the mid-nineteenth century and potentially much earlier (Fig. 13).¹

Also note remnants of whitewash on the ceiling and joists, signifying that they were originally exposed and that the lath and plaster (on the walls as well) were added later. Was the upgrade a matter of style or increased wealth? Or does it indicate a transfer in occupant from, for example, slave to farm overseer?

The falling plaster on the walls also provides an opportunity to view other clues as to age. Note that the plaster was applied to split, rather than sawn, lath and that it contains animal hair.² Also note that the lath is held by nails with irregular heads, not machine made (Fig. 14).³ Such features suggest construction prior to ca. 1825.



Figure 11



Figure 12



Figure 13



Figure 14

¹ A round log was made into a square timber by first making diagonal cuts the length of a side and then using a broad axe to slice off the scored portions of the outer layer. The opposing side was treated in the same manner (for use in framing, sometimes left partially unhewn for use as joists, etc). The log was turned 90 degrees and the process repeated on the two remaining surfaces. This method of preparing timber was used from colonial times, until the 1840s or 1850s (might still be found later, particularly in outbuildings) when technological advances made possible the mass producing of circular sawn lumber. Pitt sawn lumber was also used prior to the advent of circular saws, creating vertical (rather than circular) saw marks. For hewn timber, look for the marks of lumber split along the grain and inter-dispersed by perpendicular axe marks.

² Much like hewn versus sawn timbers, early lath was split along the grain rather than cut with a saw. Split lath usually appears in lengths of up to 4' while sawn could be twice as long. Metal lath rivaled wood lath by the end of the nineteenth century, and rock lath—the precursor to sheetrock and plaster board or drywall—was used by the early twentieth century.

³ Nail chronology can be confusing, as with other building technologies, in that the popular use of various types overlaps, and nails for framing versus finish, etc. meant that many different nails types were needed and thus can be found in a single historic structure, particularly during the early part of the nineteenth century. Generally speaking, before about 1790, nails were wrought by hand and were irregular, particularly the heads, which were T-shape or multi-faceted to create a “Rose (shaped) head.” Early machine cut nails were developed about 1790, but until the mid-1820s still had a wrought head (usually two faceted). About 1825, machine cut heads were developed. By the late 1830s, machine cut nails with uniform heads (and length) were popularly used. Wire nails of sufficient size for use in construction were developed in the third quarter of the nineteenth century and are used to the present day. (Lee H. Nelson, “Nail Chronology as an Aid to Dating Old Buildings,” National Park Service, Technical Leaflet 15, published in *History News* (December 1963).

Note that the center wall contains the chimney block (although there is no fireplace on this side). The chimney block is flanked by plastered walls and a doorway on one side, to separate the space into two same-sized rooms.

Little remains of the window and doorway surrounds or other moldings in this room, as these openings have been rebuilt and the doors and windows replaced.

Turning to the stairway area, there are indications of a former partition wall/enclosure with a doorway (see hinges in extant frame) located at the base of the stair (Fig. 15). The wide planks used to form a partition wall are visible under the stairs, but are plastered on the side facing outward into the room. It raises speculation as to why the owners felt the need for this enclosure within such a small space. Was it to create a buffer between this room (kitchen) and the next, used as a more formal parlor or dining room? Does it suggest use as a duplex or other form of shared use, particularly of the “kitchen” by unrelated individuals? Was it merely for heat conservation?

Moving into the adjoining (southern) room, it appears that this was once a more formal space, containing a fireplace with a cabinet/closet to the side opposite the doorway, and moldings around the openings. While the mantel is now gone its outline is visible, and the hole above indicates the later installation of a stove for heating (Fig. 16).

Note the molding profile of the doorway—a simple surround with a bead along the inner edge and back-band along the outer (Fig. 17). Check this profile against others in the house; differences may reveal changes, or a hierarchy of function/formality in the house, public versus private spaces.

The floor is missing here, clearly revealing the purpose of the bulkhead found outside—to provide entry into a root cellar or storage area located under this room only. Seams in the stonework on the interior wall, however, suggest access may have once been provided to a crawl space under the adjoining room (Fig.18)

Returning to the stairway, it is a partially enclosed boxed winder located to the center of the rear exterior wall of the house, providing access from both rooms and thus allowing for some privacy and sense of formality. The need for the portal window on the exterior wall is now obvious; it was inserted to light the stairway, perhaps made dark by the addition of the enclosure at its base (Fig. 19 & 20).



Figure 15



Figure 16



Figure 17



Figure 18



Figure 19

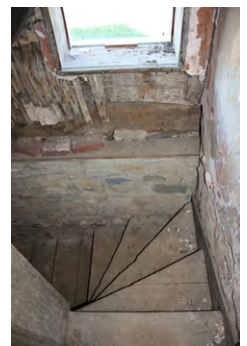

Figure 20

Interior, First Floor (main) Level:

Coming from the ground level, the stairway terminates in a small hall, providing a buffer between it and the two rooms entering from it. The variations in the door sills and flooring suggest that the doorways may not have been original, and/or that the stair “hall” may have once been open to one or both rooms (Fig. 21).

The first (main) floor contains the same basic floor plan; two equal size rooms sharing an interior wall and center chimney block. Containing the same molding profiles, the two rooms differ slightly, probably a result of varying use and to later changes.

The north room differs most significantly in that it no longer has its own exterior entry, thus rendering this room more private, and that it contains the stairway to the attic as well as a previous mode of access to attic through a hatch in the ceiling (Fig. 22).

Cracks in plaster indicate the location of a former exterior doorway, but the best evidence is provided by photographs taken prior to the most recent application of exterior siding that clearly show the entry closed over by the application of lath and plaster to the interior walls. Was this change made at the time that the walls were plastered, thus, occurring fairly early in its history?

Also, located on the ceiling against the center of the exterior side wall is a framed opening for access to the attic that was later covered over (Fig. 23). Presumably a ladder stair was once positioned against the side wall, as there is no evidence of (or space for) a more formal stair. Also visible are glimpses of the overhead floor joists that, like those below, appear to have been whitewashed.

The presence of this opening suggests that the current stairway to the attic is not original, but was added later to provide easier access to the attic. It includes a straight run to a doorway, beyond which the stair winds around 90 degrees and continues in a tight run to the attic level (Fig. 24). Other indications that the current attic stair is not original include significant differences in the size, style, and materials from those of the main stairway. Also note the walls in the enclosed portion of the stairway are plastered to the height of the attic floor where it would originally have been open to the room and to the main stairway. In addition, visible beneath the exterior siding (see Fig. 6-10) is an earlier portal opening, just above the current one, that is blocked by the current stairs to the attic.

Cracked plaster on the walls also reveals that the house is constructed of logs with chinking and galleting (in the form of stone slabs/chips) between the logs (Fig. 25).



Figure 21



Figure 22



Figure 23



Figure 24



Figure 25

The north room also contains the only surviving mantel piece, a fairly simple surround with a back band, although the shelf is missing (Fig. 26 & 27). As with the south basement room, note the hole above for a stove pipe. Also note the brick pattern in the hearth that appears to have been truncated (Fig. 28). The same holds true for the hearth in the adjoining room. It also appears that some of the floor boards around the hearth have been replaced (as also witnessed from the basement level by the lack of whitewash on those boards). Was the chimney rebuilt and reduced in size? Was it reduced to accommodate the small stair “hall” that allows for the separation of the two first-floor rooms? Note that in the attic space, the chimney is canted to the side near the top of the stair and it may have been that extra space was needed to accommodate access from it, once it was added to replace the earlier hatch and ladder stair (Fig. 29).

Note that molding profiles for the doorway and window surrounds do not match (Fig. 30 & 31). The molding profile of the doorway surround does, however, correspond to that of the fireplace (Fig. 27). The window surrounds were likely changed at a later date, either as a stylistic upgrade or the result of changes to the windows.

A look in the adjoining south room, where more plaster is missing, shows that the window openings were originally larger, and have been filled in with additional framing and brick nogging (Fig. 32). The new size is not too significant, so it may have been a simple matter of making standard-sized replacement windows fit, rather than a conscious effort to create smaller openings for, perhaps, energy efficiency.

In the south room, the falling plaster reveals that the exterior entrance received a similar treatment as the windows, reducing the opening slightly (Fig. 33 & 34). The plank and batten door is a replacement (but the one that it replaced, currently stored in the house, is of the same type).

There is a fireplace that corresponds to that in the north room, but it is missing its mantel (Fig. 35).



Figure 26



Figure 27



Figure 28



Figure 29



Figure 30



Figure 31

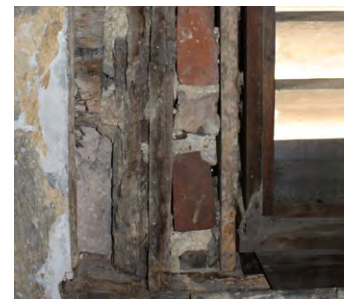

Figure 32



Figure 33



Figure 34



Figure 35

There is a built-in floor-to-ceiling cabinet in the south room against the front wall where it joins with the interior wall near the doorway between the two rooms (Fig. 36). The cabinet doors are missing but notches for hinges indicate that the cabinet was divided into upper and a smaller lower space. The molding profiles matches that of the interior doorways suggesting that it may be an original feature.

Somewhat awkward is the fact that the section of the interior partition wall that abuts the cabinet is of wood frame rather than lath-and-plaster as elsewhere (Fig. 37). Was the cabinet originally deeper, calling for infill? Was the cabinet originally located along the interior partition wall where the doorway is now found and these two rooms not accessible to one another (as in a duplex)? Is this the remnant of the original dividing wall before the lath-and-plaster walls were added?

It is also interesting to note that the molding around the doorway to the other side, where the wall is plastered, indicates that the plaster was applied *after* the molding.⁴ The same is true of the baseboards (Fig. 38). The attic is one open, unfinished space, bisected somewhat by the central chimney block, which is canted slightly to appear centered along the roof ridge, and possibly to accommodate access to the later stairway (Fig. 29, 39 & 40). The roof structure is exposed to reveal an open rafter system with rough-hewn principal rafters joined by mortise and tenon and held by pegs (Fig. 41 & 42), and then notched at the bottom end into the sill plate (Fig. 43).⁵ Simple planks have been added to create supporting “tie beams.” Narrow planks serve as common purlins to hold the roofing material.



Figure 36



Figure 37



Figure 38



Figure 39



Figure 40



Figure 41



Figure 42



Figure 43

⁴ This was an early plastering technique. The moldings were held by nailing blocks and the door or window surround and the plaster applied round them, rather than plaster first and cover the intervening spaces between the openings and walls with the molding afterwards.

⁵ This was a common joinery technique prior to the introduction of ridge boards upon which rafters were attached as part of the techniques of Balloon Framing, introduced by about 1840 and used almost exclusively for residential construction by about 1850.

Other Resources on Site:

The main house, while very different in construction and overall style, reveals a few similarities in materials and details that suggest it was built at the same time or close in period to the Secondary House. These elements include the log kitchen wing to the rear of the main house that resembles the construction technique of the Secondary House, including the V-notch joinery. Also, the mantels on the second floor of the main house—that are much more plain than those on the first—appear to be the same as those used in the Secondary House (based on the partial mantel still extant in the latter structure). Likewise, the molding surrounding the doorways in the second floor of the main house matches those in the Secondary House. Also, wide-board partition walls appear in the Secondary House (under the stair) and in the service wing of the main house. Archeological (and written) evidence also reveals that there was a row of slave quarters located in the fields just beyond the Secondary House, that would suggest that this structure was not constructed as a residence for slaves, but as an overseer’s house or as a dependency for the main house.

Brief Historical Information:

There are two theories about the origins of the Secondary House. The first is that it—or at least the stone-constructed, ground level of it—was erected by a tenant farmer, George Beckwith, who occupied some portion of this property from 1761 until about 1794, along with his sons Charles and Basil. According to Beckwith’s lease from absentee landholder Daniel Dulany, he was obligated to “keep in good tenantable repair the house already erected on the said devised premises, and to erect or build others of equal goodness.” Likewise, his contract called for the construction of a dwelling with a stone or brick chimney and a barn.⁶ However, it is not certain what that house consisted of, or even if it was on this portion of Dulany’s substantial tract, other parts of which were also tenanted.

The more likely theory is that this house, along with the main house and the stone barn, were erected by/for the Vincendiere family, who emigrated just before the turn of the nineteenth century from St. Dominigue (Haiti), and formerly from France. They relocated to the Frederick area as early as 1792 and accumulated the parcels of land that formed their plantation of over 700 acres, between 1795 and 1798. A June 1798 account of a traveler through this area described on the property (as seen from the road) “a row of wooden houses and one stone house with upper stories painted white” that would appear to be this house and the former row of slave cabins known to exist in the fields between this house and the Frederick Road.⁷ The fact that he mistakenly described the upper stories as stone painted white is an indication that the log walls of the upper story were sided rather than left exposed, and he assumed that the upper stories were of the same construction as the basement. Tax assessment records from 1798 likewise indicate “new improvements” to the property at that time. The main house, which also contains a log section of similar construction (believed to have been built as a free-standing kitchen incorporated into the main house in the 1860s) to the Secondary House, was erected soon thereafter. By 1800, the census indicates that the property accommodated a household of eighteen persons (family and fellow refugees) and ninety slaves.

⁶ Paula Stoner Reed, Cultural Resources Study, Monocacy National Battlefield. Washington, DC: U.S. Government Printing Office, 2004 (updated), 92. According to Reed, the text cited was part of the standard contract that Delany issued. Dulany Legal Papers, Maryland Historical Society, MS#1562[a].

⁷ Julian Ursyn Niemcewicz, *Under Their Vine and Fig Tree, Travels through America in 1797-1799, 1805*; Vol. XIV in the Collections of the New Jersey Historical Society at Newark (Elizabeth, NJ: The Grassmann Publishing Company, Inc.,), 111.

Although the log construction of the Secondary House is fairly typical for this region, the raised, stone, ground level with kitchen is somewhat unusual. One explanation is that its unusual form is a factor of the blending of vernacular building traditions of both of this region and of the French and French Colonial regions from which its owners originated. Elements influenced by French and St. Dominique building traditions include the raised basement, the combination of a stone first floor and log upper stories with chinking (manifested in the French colonies as “bousillage,” or timber framing with Spanish moss infill), and a “salle-and-chambre” plan (although the rooms of the Secondary House are of equal size rather than a slightly larger “salle” and adjoining “chambre”), that is also common in American Creole house forms. The original use of the structure is not known; some accounts suggest that the Vincendiere family first erected it as their own dwelling while constructing the main house, then used it for extended family and fellow refugees. Evidence of a former row of slave houses further suggests that this structure was part of a social hierarchy within their plantation complex. The fact that the kitchen entry in the Secondary House faces towards the slave row may indicate that it was available for the use of their slave population as well. The Secondary House was used as a tenant house by the Best Family who owned the property beginning in about 1843.⁸

⁸ Their ownership and presence here during the Civil War, Battle of Monocacy is reason why NPS has named this the “Best Farm” property.

HISTORIC AMERICAN BUILDINGS SURVEY

BEST FARM, SECONDARY HOUSE
(L' Hermitage, Secondary House)

HABS NO. MD-1171-A

Location: 4871 Urbana Pike, Monocacy National Battlefield, Frederick, Frederick County, Maryland, 21704. The Secondary House faces southwest towards the front façade of the main house, with rear doorways at ground-level opening onto the farm fields where a row of slave cabins once stood, and beyond to Urbana Pike, the main thoroughfare into Frederick.

The coordinates for the house are 39.370647 N, 77.397872 W and were obtained through Google Earth in December 2010 using NAD 1983. There is no restriction on the release of the locational data to the public.

Significance: The Secondary House was erected in the 1790s by the Vincendiere family, immigrants to the Frederick area from the French colony of St. Dominique (Haiti) in the West Indies. Its log construction is fairly typical of vernacular dwellings built in Western Maryland during this period, yet the house also exhibits accommodations made with respect to the building traditions of the Vincendiere's former homeland. Most significantly, features such as the substantially raised ground level, the basement kitchen, and the doorways that once opened from the first floor rooms onto a porch or gallery are characteristic of structures erected in tropical environments such as the West Indies. Many of these characteristics were transferred to coastal Louisiana where they are now identified with American Creole architecture. The chinked log construction of the Secondary House, while not expressly used in this manner in the French colonies, can be interpreted as a variation on French "bousillage" construction whereby vertical log framing is filled in with a mixture of mud and indigenous Spanish moss. Likewise, the two-room plan of the house is similar to both the English hall-and-parlor plan typical of this region and the French salle-and-chamber plan, although the same-size rooms and central chimney exhibited here (particularly on the first floor) more closely resembles duplex quarters used as slave housing.¹

The original use of the Secondary House is not known and, moreover, it appears to have been modified over time to accommodate new uses and/or occupants. The Vincendieres may have erected this structure before the main house, occupying it while their own dwelling was under construction, then adapting it as lodging for extended family and fellow refugees from St. Dominique. While exhibiting none of its grandeur, some of the architectural elements that appear in the private spaces of the main house, such as the service wing and second-floor chambers, match those found in the Secondary House. Application of these features to the Secondary House, including mantels, chair rail, window and door surrounds, as well as plastered walls and ceilings, also suggests occupancy by those other than slaves or low-ranking servants. Evidence of a former row of slave houses located between Urbana Pike and this structure further indicates that it

¹ The rooms of the Secondary House, however, are of equal size rather than a slightly larger "salle" and adjoining "chambre" in the French tradition.

was part of a social hierarchy of domestic dwellings appearing within the plantation landscape.

Description: The Secondary House is a single-story, two-cell plan structure of chinked logs covered in wood siding and resting on a raised stone basement. It measures three bays (two bays to the rear) across by one-bay deep, and has a side-gable roof. The front façade as built was symmetrically balanced with an entry at either end, resembling a typical, duplex style quarter. The house consists of two rooms per floor with a small enclosure at the top and bottom of the stairway to create only a limited intervening space between rooms. It has a central brick chimney block to provide heat, and a large stone chimney with a brick stack at the ground level northwest room for cooking purposes. The house was recently re-sided; due to the good condition of the logs underneath (and an early description of the house), it is assumed that the structure has always been sheathed in wood siding. One of the two front entries has been filled in.² The remaining entry is no longer accessible due to the removal of the front porch or stoop(s). Entry is currently provided by the two symmetrically placed doorways to the rear of the tenant house, at the ground level. The windows were removed and ventilation panels installed when the house was “mothballed,” but remnants of the previous sash currently stored in the house indicate that they were last six-over-six-light sash.

Evidence indicates that the original windows have been replaced; the openings were filled in with new framing members and brick nogging.³ The original window type is not known. There are two windows at each of the front and rear elevations of the first floor, clustered towards the center of the structure to allow for doorways on the front façade and to facilitate cross ventilation in hot weather. There are no windows at the ground level of these elevations. Each of the two basement rooms is lit by a single window located at the side elevation, towards the rear of the building. A small, fixed window or portal was cut into the center of the rear façade, at about the level of the sill of the windows, in order to light the interior stairway.⁴ There is a window on the first floor of the southeast elevation, towards the front, but no corresponding window on the other side due to the placement of the stone chimney. Windows also appear in both gable ends. As with the windows, changes have also been made to the doorways. On the first floor, one doorway was covered over on the interior by lath-and-plaster walls and on the exterior by the siding, and the other doorway was reduced in size. Due to their deteriorating condition, the door frames were reconstructed and new doors made to resemble the original ones consisting of planks held with battens (one of which is currently being stored in the house). At the basement level, the doors are

² The former opening is currently evident from cracking plaster on the interior walls and was also documented through photographs taken for HABS with the log walls exposed, prior to re-siding.

³ The new window size is not too significant so it may have been undertaken to accommodate standard-sized replacement windows rather than as a conscious effort to create smaller openings for energy efficiency or aesthetic purposes.

⁴ A similar portal was cut into the log walls prior to the current opening, but was covered over by a stairway that was added between the main floor and the attic, thus necessitating the new portal.

new and are Dutch-style so that the bottom and top sections can be opened separately (thus allowing park visitors to peer inside without entering).⁵ The gable roof is now covered with raised-seam metal.

The formal entry was located to one end of the southwest façade (again, the northerly one has been covered over). The presence of individual entries into each of the two rooms of the main floor suggests that the house may originally have been used as a duplex. A small winder stair hall to the center and back of the house, enclosed at the top and bottom, further allowed for separation of the two primary rooms (although the rooms are currently connected by a doorway). Access to the unfinished attic space was originally provided via a hatch in the ceiling of the northwest room, presumably with a ladder stair. A partially enclosed stairway has since been added to the northern room, above the main stair. Evidence that conflicts with the notion that the house was used as a duplex is the fact that only one basement room contains a large fireplace and hearth for cooking, while the other room appears to have been finished in a more formal manner, possibly for use as a dining room and/or parlor. It may be that the house was originally intended for use as a duplex (possible with a shared kitchen), but was changed early on, which would explain why the exterior doorway was removed from the north room of the first floor (and the doorway between the two rooms possibly added.)

The interior consists of two adjoining rooms per floor at both the basement and first floor level, with an unfinished attic. The house has been abandoned for some time and is in stable but deteriorating condition. Plaster is falling and moldings, windows, and original doors are missing throughout. However, remaining molding suggests that most of the finish was done at one time, with the exception of the windows and the first floor exterior doorway that received new moldings when they were replaced (and reduced in size). Whitewash on the beams, now visible due to falling ceiling plaster, suggests that the beams/floor joists were once exposed. Thus, the plaster was a later refinement. In fact, the moldings appear to have been applied before the plaster, which may merely indicate the antiquity of the plaster, as that was once common practice, suggesting that it was applied early on. The basement floor appears to have been used as a kitchen and parlor or dining room/parlor. The kitchen space includes a large fireplace with arched opening. Ghost images of former wainscoting and/or cabinetry are visible. Adjoining this is a room of the same size but more formal in its finish, including a fireplace (mantel missing) with a chimney closet to one side. The floor is now missing, exposing a root cellar. A boxed winder stairway adjoins the ground and first floors, terminating in a small hall that allows privacy for the two first floor rooms.

⁵ The doors were missing at the time that NPS acquired the property, so their appearance is unknown. Most likely, they resembled the vertical plank doors held with battens that appeared to the front of the house (now stored inside).

The second floor rooms served either as bed chambers or as multi-purpose living and sleeping chambers when the entries to both were in place, and perhaps once the one exterior entry was removed, as a parlor and a (more private) bed chamber. Both rooms have a fireplace on the common, interior wall. The mantel is extant in the north room only, consisting of a plain surround with back band. Cracking and falling plaster reveals a number of features including the log walls chinked with stone galleting, and the changes in the doorway and window openings. The north room also includes a former opening for access to the attic, and a partially enclosed winder stair to the attic. The truncated pattern in the brick hearths in both rooms suggest that the chimney stack may have been altered from the original, possibly to accommodate access via the new stair to the attic. The south room includes a built-in cabinet on the front wall abutting the doorway into the adjoining room. It is interesting to note that a portion of the partition wall between the cabinet and the fireplace is beaded board, rather than lath-and-plaster, suggesting the later addition of, or change to, the doorway between the two rooms.

The attic is a single, unfinished space, bisected somewhat by the central chimney block, which is canted slightly to appear centered along the roof ridge while also allowing enough space to access the new stairway that emerges at that location. The roof structure is exposed to reveal an open rafter system with roughly hewn principal rafters joined by mortise and tenon at the top and then notched into the sill plate below. Simple planks have been added to create supporting "tie beams." Narrow planks serve as common purlins to hold the roofing material.

History: The Secondary House was likely built just before the turn-of-the-nineteenth century by the Delavincendiere family (a/k/a De La Vincendiere or, as it was eventually simplified, Vincendiere). The Vincendieres emigrated here in 1793 from the West Indies colony of St. Dominique (Haiti), and were formerly from France. They were among the many escaping the slave uprising that began in 1791 and had operated a plantation in St. Dominique, bringing with them to Maryland at least twelve enslaved persons.⁶ As suggested, this structure may have been used as their dwelling house while undergoing construction of the main house, and then used to house extended family and fellow refugees, or perhaps a plantation overseer. The first parcel of what would eventually become a much larger plantation was purchased by an agent for Victoire Pauline Marie Gabrielle Vincendiere in March of 1795, although evidence suggests that the family was already living on the site by that time.⁷ Information indicates that Victoire and

⁶ For more information about the Vincendieres, their background and experiences in St. Dominique and Frederick see, Paula Stoner Reed, "L'Hermitage on the Monocacy Battlefield, Frederick, Maryland." In *Material Culture in Anglo-America*, David S. Shields, ed. (Columbia: University of South Carolina Press, 2009), 127-154. Also, Paula Stoner Reed, *Cultural Resources Study, Monocacy National Battlefield* (Washington, DC: U.S. Government Printing Office, 2004 (updated)), 90-101.

⁷ Frederick County Land Records, Liber WR 13, folio 397, Frederick County Courthouse, Frederick, Maryland. The parcel contained 457 acres.

her family arrived in “Frederick Town in Maryland” as early as December 1793.⁸ Based on the will of a French refugee living with the Vincendieres that is dated December 23, 1794, they were living on the property at that time. However, the adjoining parcel upon which the main and secondary houses sit was not acquired until 1798.⁹ Thus it is possible that they were living an existing structure on the property at the time of its purchase. The text of the will states that it was written from “Chambre Sud du Pavillion Est” or the south chamber of the east pavilion.¹⁰ This statement has been interpreted by some to be a reference to the Secondary House as a “pavilion” to the main house.¹¹

Further evidence of the construction of the Secondary House prior to the turn-of-the-nineteenth century exists. A June 1798 account of a traveler through this area described on the property “a row of wooden houses and one stone house with upper stories painted white” that would appear to be the Secondary House and the former row of slave cabins known to have existed in the fields between it and the road to Frederick.¹² The fact that he mistakenly described the upper stories as stone painted white is an indication that the log walls of the upper story were sided rather than left exposed, and that from a distance, could not be distinguished other than by color. Likewise, the assumption that the upper story was also stone suggests how unusual a raised log house may have appeared to one observing the dwellings of this region. Tax assessment records for Frederick County from 1798 likewise indicate “new improvements” to the property at that time.¹³ The main house, which also contains a log section of similar construction to the Secondary House, was likely erected soon thereafter.

It is unclear as to why the Vincendieres chose to settle in Frederick, although it was among the most populous and prosperous farming regions in the state. In fact Frederick flour was routinely exported to the West Indies where it was very highly regarded, a reputation with which the Vincendieres as planters were likely

⁸ According to the family’s “Declaration of Negroes” filed 24 December 1793, which indicates that they were at that time residents of “Frederick Town.” Reed, “L’Hermitage on the Monocacy Battlefield,” 130.

⁹ Frederick County Land Records, Liber WR 10, folio 124. This parcel added 291 acres for a total of 748 acres.

¹⁰ Frederick County Probate Records, Will for Pierre Laberon, Liber G.M. 3, folio 27, Frederick County Courthouse, Frederick, Maryland.

¹¹ Reed, “L’Hermitage on the Monocacy Battlefield,” 152. Heather Hembrey and Joy Beasley speculate that, “if the word *pavilion* is translated to refer to a “small detached dwelling” or “cabin,” associated with the larger house it might be inferred that Laberon wrote his will from the south chamber of the secondary dwelling.” Heather A.E. Hembrey and Joy Beasley, “A Study of Land Tracts Comprising L’Hermitage, 1724-1798.” *In Archeological Overview and Assessment and Identification and Evaluation Study of the Best Farm*, Joy Beasley, ed. (Washington, DC: Department of the Interior, National Capital Region, National Park Service, 2005), 4.10.

¹² Julian Ursyn Niemcewicz. *Under Their Vine and Fig Tree, Travels through America in 1797-1799, 1805*; Vol. XIV in the Collections of the New Jersey Historical Society (Elizabeth, NJ: The Grassmann Publishing Company, Inc., 1965), 111.

¹³ Frederick County Tax Assessment, 1798. C.Burr Artz Library, Maryland Room, Frederick, Maryland.

familiar.¹⁴ In addition, other émigrés already inhabited a “Frenchtown” within downtown Frederick.¹⁵

By 1800, the census indicates that Victoire was living at this site with a household of eighteen family members and invited individuals, and ninety slaves, making the Vincendieres one of the largest slaveholders in Frederick County.¹⁶ By 1810 the census records indicates a household of eight individuals (including Victoire) and ninety slaves, and by 1820 there were twelve household members, forty-eight slaves, four “free” and two “not naturalized” residents. The family resided here until 1827, when they sold the property to the John Brien and moved into the town of Frederick.¹⁷ In 1835 L'Hermitage was sold to wealthy local landowner John H. McElfresh and it remained in the family until sold to the National Park Service in 1993. The property was later transferring to his daughter Ariana, who married Charles E. Trail in 1852. The McElfresh/Trail family never lived here, however. Instead the farm was occupied and operated by tenants until the last one vacated in 1999.

The property is commonly known as the Best Farm for its long-time tenants, beginning with David Best as early as 1843 and extending to late in the century.¹⁸ According to census records for 1850, Best had a wife and four children in addition to seven slaves, a free-black house servant and a laborer, and eight (white) men assisting him on the farm.¹⁹ By 1860 the numbers had increased to seven family members, two free blacks including a “House Servant,” three male slaves and eight (white) laborers.²⁰ It is therefore likely that the Secondary House was used to house some of these workers. It has also been speculated that David Best may have retired to the Secondary House when he turned the farm over to his son, John T. Best, in 1863.²¹ The 1870 Census includes among those living on the farm other than family, five white labors and one mulatto worker. Best grew primarily wheat, corn, oats, and hay, and by the post-Civil War era also operated a successful dairy farm here. By 1870, Best was able to purchase his

¹⁴ Reed, “L'Hermitage on the Monocacy Battlefield,” 128. Reed has also suggested that their agent, local merchant and landholder James Marshall, may have had a prior business relationship with the Vincendieres and helped to establish them in Frederick (and probably before they obtained legal title to the property; Reed, 137.

¹⁵ Joy Beasley, “Occupational History of the Best Farm,” *In Archeological Overview and Assessment*, 3.6.

¹⁶ 1810 U.S. Population Census Records, Frederick County, Maryland Archives, Annapolis, Maryland; and Reed, “L'Hermitage on the Monocacy Battlefield,” 143-144.

¹⁷ Frederick County Land Records, Liber JS26, folio 551. According to Paula Reed, Victoire had a townhouse built for her in Frederick and lived there for the rest of her life; Reed, *Cultural Resource Study*, 98.

¹⁸ David Best's occupation is documented in a mortgage record for a loan from the widow of John McElfresh, presumably for funds needed to operate the farm. Frederick County Land Records, Liber HS 18, folio 474.

¹⁹ 1850 U.S. Population Census and Slave Census schedules.

²⁰ *Ibid.*, 1860.

²¹ Deposition by John T. Best, son of David Best, C.E. Trail Quartermaster Claim, #R-153, National Archives, RG 92. In addition, the 1870 Census lists David Best in a separate household on the property next to his son John and his wife and daughter.

own property, but remained as a tenant on the L'Hermitage.²² According to historian T.J.C. Williams, "For over forty years he [John T. Best] carried on a flourishing dairy business, which was a source of much revenue to him" and in 1888 he moved from L'Hermitage to his own farm where he had built a house.²³ Best did, however, continue to lease the property until about 1890.

The 1910 Population Census Records indicate that Jonas Summers was renting the property, along with his wife and seven children. A farm hand, Hela Summers, his wife and baby appear next in the listing, suggesting that they were residing closest to the main house and thus likely in the Secondary House.²⁴ They had all vacated by 1920 and L'Hermitage was rented to various tenant farmers until 1924 when first occupied by Courtney Wiles and family who, like Best, operated a dairy farm here. By about 1930, Elmer Wiles took over operation of the farm and Courtney moved into the Secondary House, which was electrified for his convenience. No other amenities appear to have been added, and even the main house did not receive indoor plumbing until 1950s.²⁵ By the late 1960s, the Secondary House was abandoned; the lower level was used as a root cellar and animals were allow to roam through, while the first floor was used to house rabbits.²⁶ The Wiles family continues to farm the property, but gave up residency in 1999. By that point it was already owned by the National Park Service, who had purchased the property in 1993. The house has been stabilized, including new siding, roofing, doorways and doors, and ventilators installed in the window openings.

Sources: Beasley, Joy, ed. *Archeological Overview and Assessment and Identification and Evaluation Study of the Best Farm*. Washington, DC: Department of the Interior, National Capital Region, National Park Service, 2005.

Frederick County Land Records, Frederick County Courthouse, Frederick, Maryland.

Frederick County Probate Records, Frederick County Courthouse, Frederick, Maryland.

Niemcewicz, Julian Ursyn. *Under Their Vine and Fig Tree, Travels through America in 1797-1799, 1805*; Vol. XIV in the Collections of the New Jersey

²² 1870 U.S. Population Census. The records list property that Best owned elsewhere. 1870 Agricultural Census, Maryland Archives, indicated that he still resided at L'Hermitage, with all 425 acres improved.

²³ T.J.C. Williams, *History of Frederick County*, (Baltimore: Regional Publishing Company, 1967 reprint of 1910 edition), 900.

²⁴ 1910 U.S. Population Census.

²⁵ Beasley, *Archeological Overview and Assessment*, 3.24; cites interview with Kenny Wiles by Joy Beasley, 2002.

²⁶ From Monocacy National Battlefield, Survey 7, February 10, 1997, "Walk-through of the Best, J.T./Trail, C.E. House (Wiles)," and interview with Keith and Michelle Wiles (Wiles grandson and wife, residents), as cited in Reed, *Cultural Resources Study*, 108.

BEST FARM, SECONDARY HOUSE
(L' Hermitage, Secondary House)
HABS No. MD-1171-A (page 8)

Historical Society at Newark. Elizabeth, NJ: The Grassmann Publishing Company, Inc.,

Reed, Paula Stoner and Edith B. Wallace. *Monocacy National Battlefield Cultural Resource Study*. Washington, D C: U.S. Government Printing Office, November 1999; updated July 2004.

Reed, Paula Stoner. "L'Hermitage on the Monocacy Battlefield, Frederick, Maryland." In *Material Culture in Anglo-America*, David S. Shields, ed., Columbia: University of South Carolina Press, 2009.

U.S. Population Census, Maryland Archives, Annapolis, Maryland (various years 1850-1910).

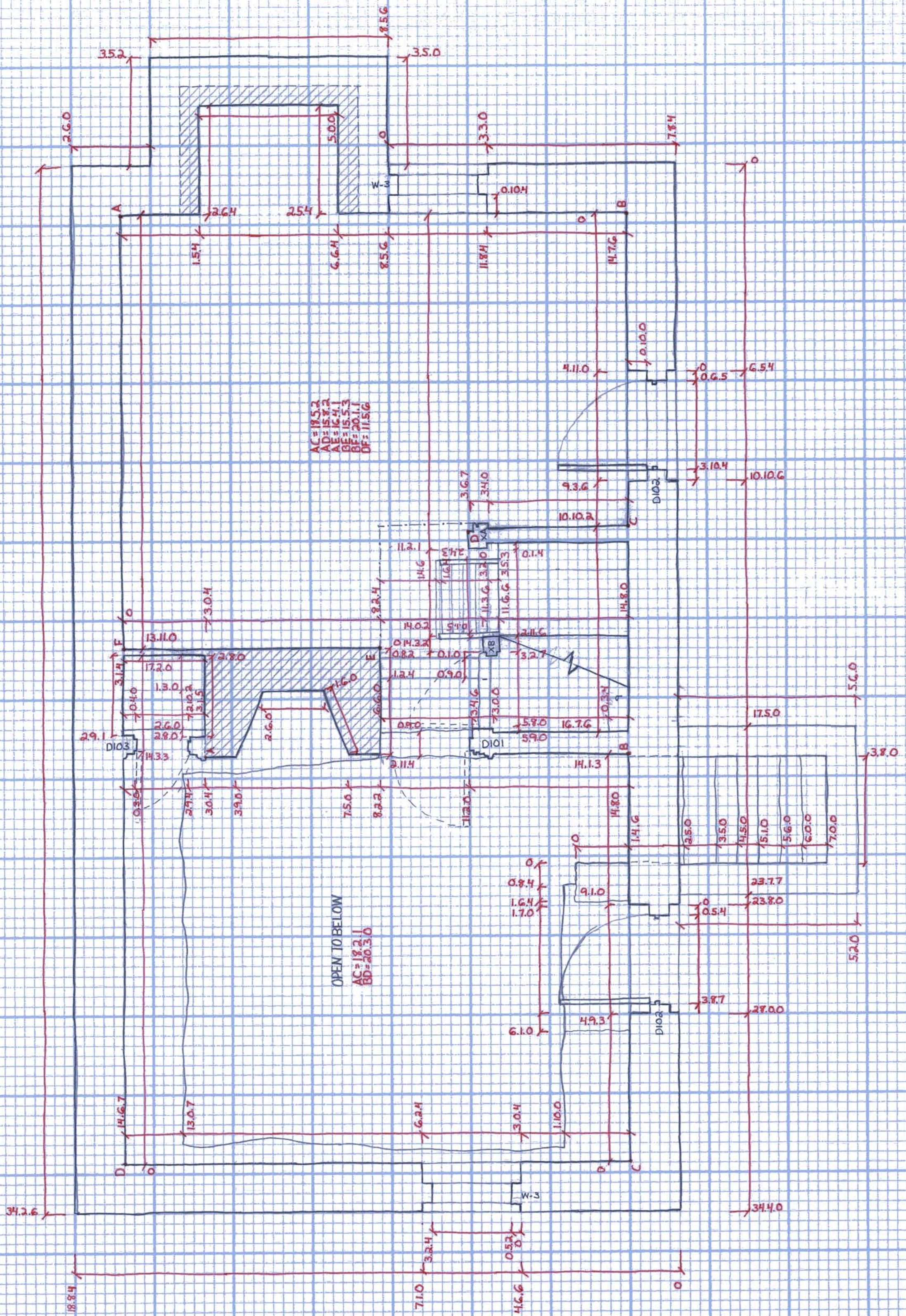

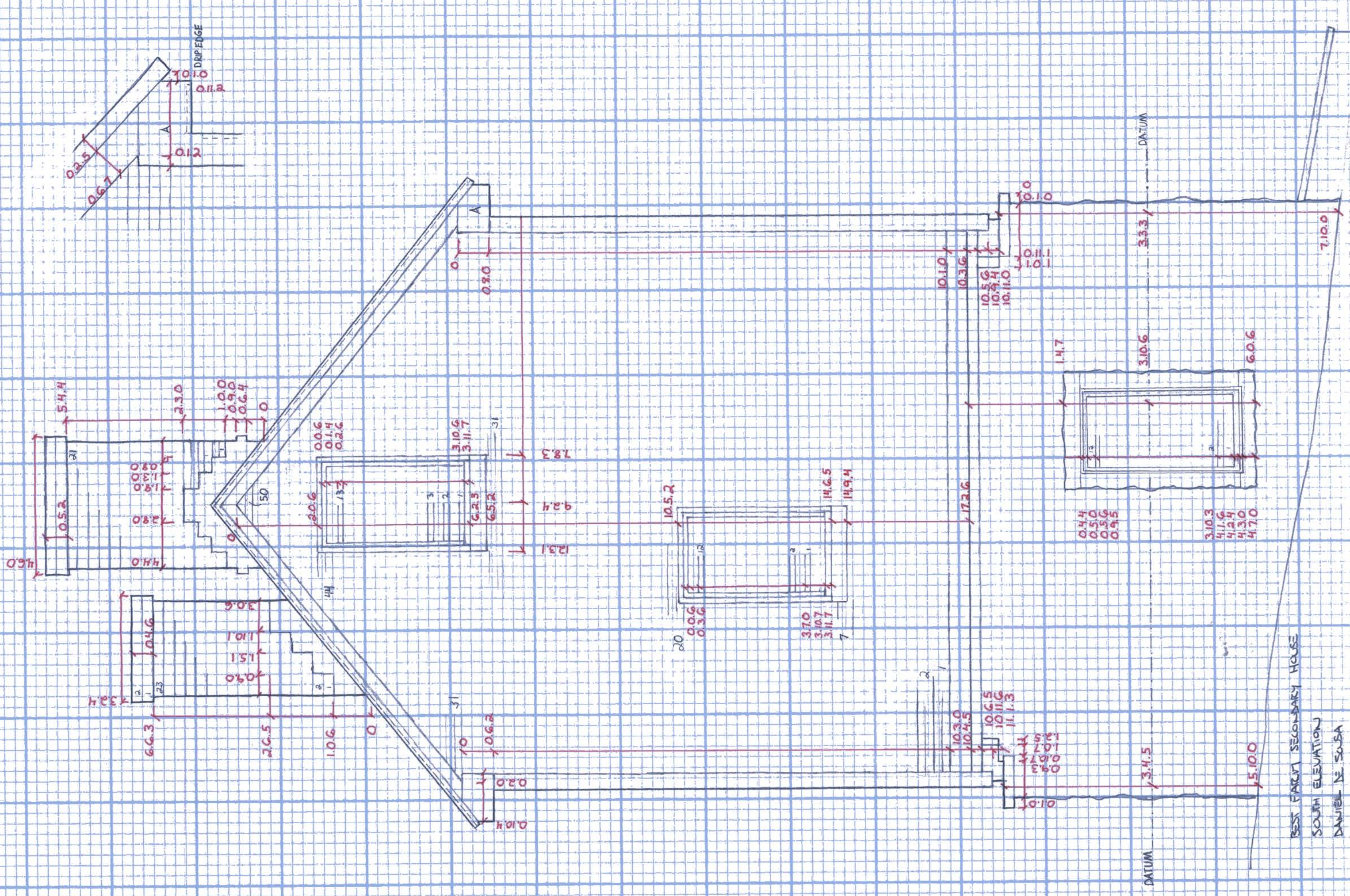

BEST FARM SECONDARY HOUSE
 SOUTH ELEVATION
 DANIEL DE SOUSA
 SEPTEMBER 200
 HABS # MD-1171-A

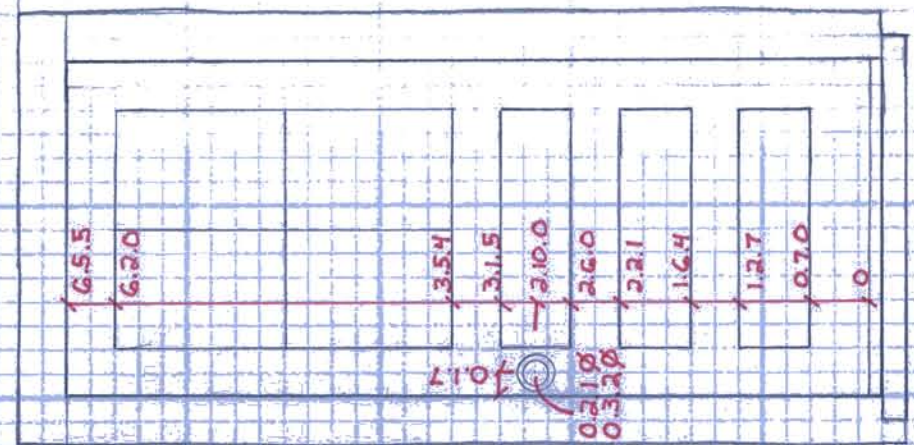
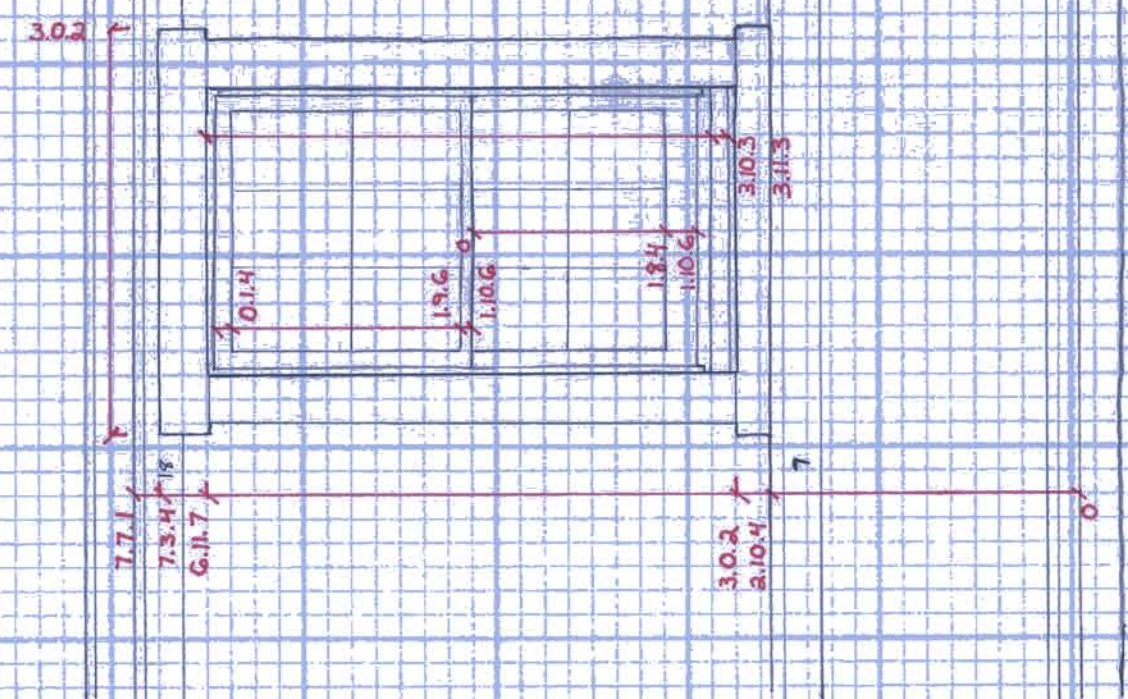
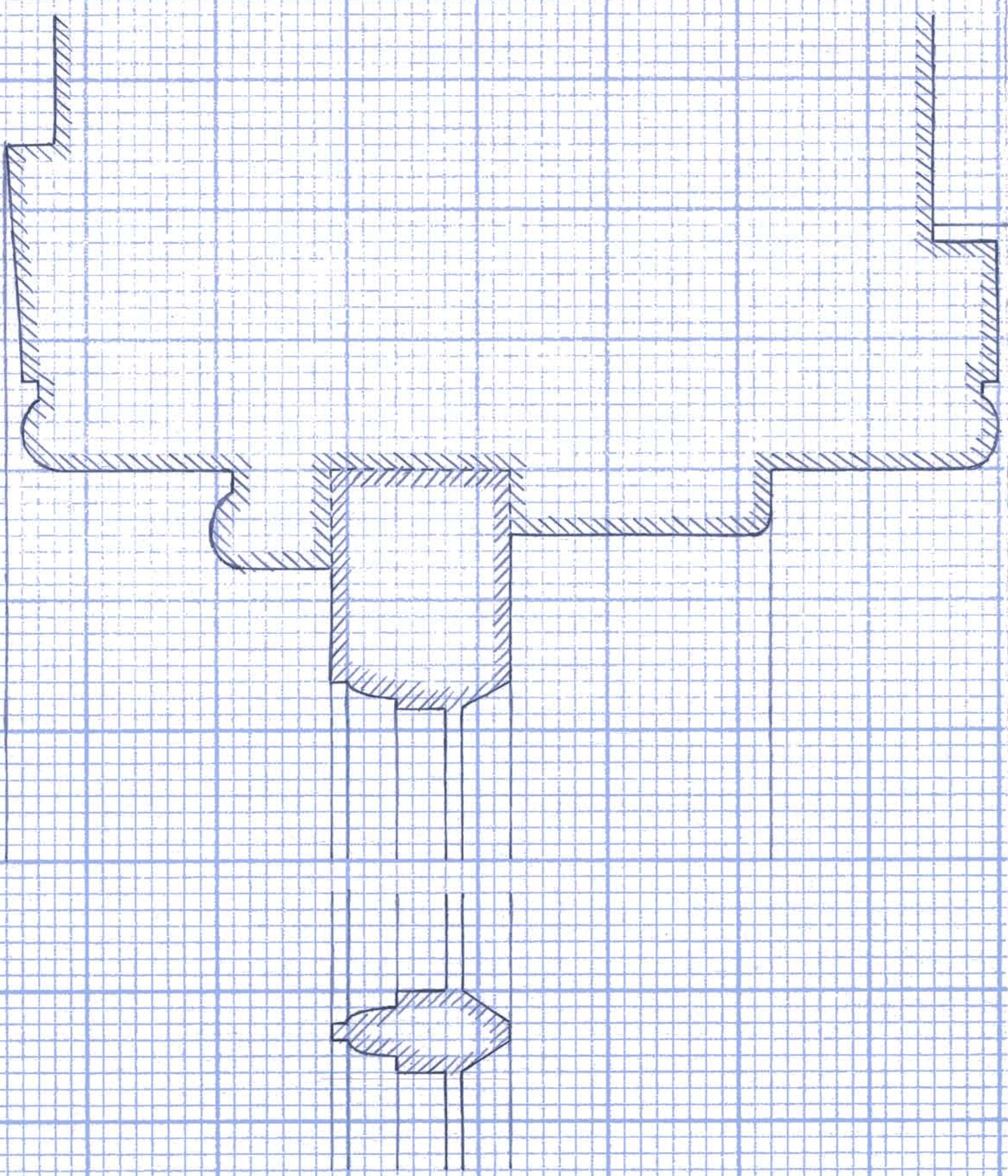
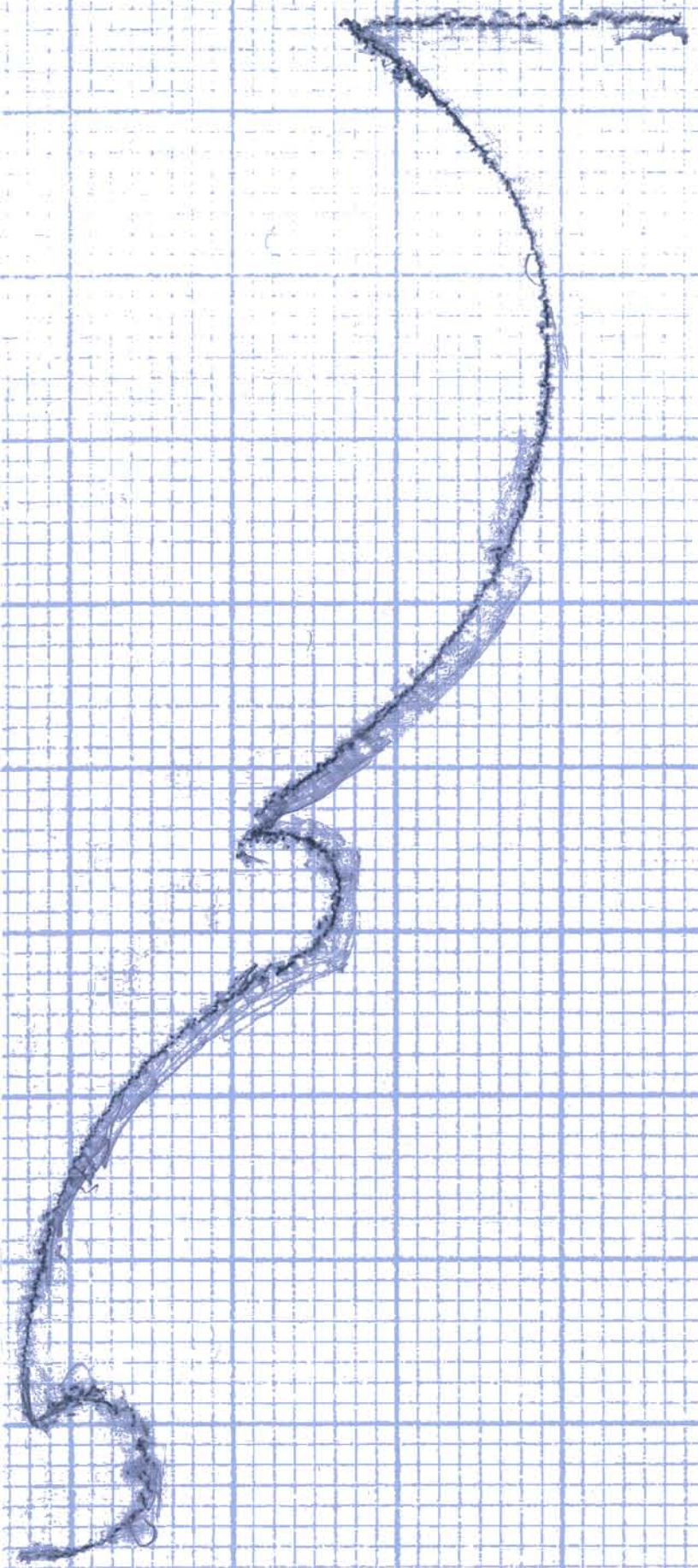

BEST FARM MAIN HOUSE
 DETAILS
 PAUL DAVIDSON, DANIEL DE SOUSA
 SEPTEMBER 2010