

United States Department of the Interior
National Park Service

National Register of Historic Places
Registration Form

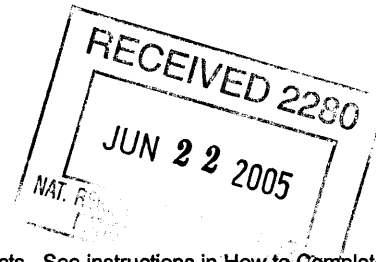

This form is for use in nominating or requesting determinations for individual properties and districts. See instructions in How to Complete the National Register of Historic Places Registration Form (National Register Bulletin 16A). Complete each item by marking "x" in the appropriate box or by entering the information requested. If any item does not apply to the property being documented, enter "N/A" for "not applicable." For functions, architectural classification, materials, and areas of significance, enter only categories and subcategories from the instructions. Place additional entries and narrative items on continuation sheets (NPS Form 10-900a). Use a typewriter, word processor, or computer, to complete all items.

1. Name of Property

historic name Siuslaw River Bridge No. 01821

other names/site number Siuslaw River (Florence) Bridge No. 01821E

2. Location

street & number Oregon Coast Highway No. 9 (US 101), MP 109.98 not for publication

city or town Florence vicinity

state Oregon code OR county Lane code 039

zip code 97439

3. State/Federal/Tribal Agency Certification

As the designated authority under the National Historic Preservation Act of 1986, as amended, I hereby certify that this nomination request for determination of eligibility meets the documentation standards for registering properties in the National Register of Historic Places and meets the procedural and professional requirements set forth in 36 CFR Part 60. In my opinion, the property meets does not meet the National Register Criteria. I recommend that this property be considered significant nationally statewide locally. (See continuation sheet for additional comments.)

James Hamrick 6/17/05
Signature of certifying official / Deputy SHPO Date

Oregon State Historic Preservation Office
State or Federal agency and bureau

In my opinion, the property meets does not meet the National Register criteria. (See continuation sheet for additional comments.)

Signature of commenting or other official Date

State or Federal agency and bureau

4. National Park Service Certification

I, hereby certify that this property is:

entered in the National Register Edson Beall 8/5/05
 See continuation sheet.

determined eligible for the National Register
 See continuation sheet.

determined not eligible for the National Register

removed from the National Register

other (explain): _____

Jan
Signature of Keeper

Date of Action

5. Classification

Ownership of Property

(Check as many boxes as apply)

- private
public-local
public-State
public-Federal

Number of Resources within Property

(Do not include previously listed resources in the count)

Table with 2 columns: Contributing, Noncontributing. Rows: buildings, sites, structures, objects, Total. Value 1 is entered under Contributing structures.

Number of contributing resources previously listed in the National Register 0

Category of Property

(Check only one box)

- building(s)
district
site
structure
object

Name of related multiple property listing

(Enter "N/A" if property is not part of a multiple property listing.)

C. B. McCullough Major Oregon Coast Highway Bridges, 1927-36.

6. Function or Use

Historic Functions

(Enter categories from instructions)

Transportation

Current Functions

(Enter categories from instructions)

Transportation

Historic Subfunctions

(Enter subcategories from instructions)

Road-related

Current Subfunctions

(Enter subcategories from instructions)

Road-related

7. Description

Architectural Classification

(Enter categories from instructions)

- Late 19th and 20th Century Revival
Classic Revival
Late Gothic Revival
Modern Movement
Moderne
Art Deco

Materials

(Enter categories from instructions)

- Foundation
Other
Concrete
Steel
Concrete

Narrative Description

(Describe the historic and current condition of the property on one or more continuation sheets)

See continuation sheets.

8. Statement of Significance

Applicable National Register Criteria

(Mark "x" in one or more boxes for the criteria qualifying the property for National Register listing)

- A Property is associated with events that have made a significant contribution to the broad patterns of our history.
B Property is associated with the lives of persons significant in our past.

C Property embodies the distinctive characteristics of a type, period, or method of construction or represents the work of a master, or possesses high artistic values, or represents a significant and distinguishable entity whose components lack individual distinction.

D Property has yielded, or is likely to yield information important in prehistory or history.

Criteria Considerations

(Mark "X" in all the boxes that apply.)

A owned by a religious institution or used for religious purposes.

B removed from its original location.

C a birthplace or a grave.

D a cemetery.

E a reconstructed building, object, or structure.

F a commemorative property.

G less than 50 years of age or achieved significance within the past 50 years.

Areas of Significance

(Enter categories from instructions)

Engineering
Transportation

Period of Significance

1933-36

Significant Dates

Completed in 1936.

Significant Person

(Complete if Criterion B is marked above)

Cultural Affiliation

Architect/Builder

Conde B. McCullough, Oregon State Bridge Engineer, designer
Mercer-Fraser Company, Eureka, California, contractor

Narrative Statement of Significance

(Explain the significance of the property on one or more continuation sheets.)

See continuation sheets.

9. Major Bibliographical References

(Cite the books, articles, and other sources used in preparing this form on one or more continuation sheets.)

Previous documentation on file (NPS)

preliminary determination of individual listing (36 CFR 67) has been requested.

previously listed in the National Register

previously determined eligible by the National Register

- designated a National Historic Landmark
- recorded by Historic American Buildings Survey # _____
- recorded by Historic American Engineering Record # OR-58

Primary Location of Additional Data

- State Historic Preservation Office
- Other State agency
- Federal agency
- Local government
- University
- Other

Name of repository: Prints and Photographs Division, US Library of Congress.

10. Geographical Data

Acreage of Property 2.16 acres

UTM References

(Place additional UTM references on a continuation sheet)

1	10	411156	4868317	3	
	Zone	Easting	Northing		Zone Easting Northing
2				4	

Verbal Boundary Description

(Describe the boundaries of the property on a continuation sheet.)

Boundary Justification

(Explain why the boundaries were selected on a continuation sheet.)

11. Form Prepared By

name/title Robert W. Hadlow, Ph.D., Senior Historian

organization Oregon Department of Transportation date June 30, 2004

street & number 123 NW Flanders Street telephone (503) 731-8239

city or town Portland state OR zip code 97209-4037

Additional Documentation

Submit the following items with the completed form:

Continuation Sheets

Maps

- USGS map** (7.5 or 15 minute series) indicating the property's location.
- sketch map for historic districts and properties having large acreage or numerous resources.

Photographs

Representative **black and white photographs** of the property.

Additional items (Check with the SHPO or FPO for any additional items)

Property Owner

(Complete this item at the request of the SHPO or FPO.)

name Oregon Department of Transportation

street & number 355 Capitol Street NE telephone _____

city or town Salem state OR zip code 97301

Paperwork Reduction Act Statement: This information is being collected for applications to the National Register of Historic Places to nominate properties for listing or determine eligibility for listing, to list properties, and to amend existing listings. Response to this request is required to obtain a benefit in accordance with the National Historic Preservation Act, as amended (16 U.S.C. 470 et seq.).

Estimated Burden Statement: Public reporting burden for this form is estimated to average 18.1 hours per response including the time for reviewing instructions, gathering and maintaining data, and completing and reviewing the form. Direct comments regarding this burden estimate or any aspect of this form to the Chief, Administrative Services Division, National Park Service, P.O. Box 37127, Washington, DC 20013-7127; and the Office of Management and Budget, Paperwork Reductions Project (1024-0018), Washington, DC 20503

United States Department of the Interior
National Park ServiceNATIONAL REGISTER OF HISTORIC PLACES
CONTINUATION SHEETSection 7 Page 6Siuslaw River Bridge No. 01821
Name of PropertyLane County, Oregon
County and State

Narrative Description

The Siuslaw River Bridge is a bridge is a reinforced-concrete structure with a bascule span at its center. It spans the Siuslaw River between the communities of Florence and Glenada at milepost 109.98 on the Oregon Coast Highway No. 9 (US 101) in Lane County, Oregon. It is the smallest of the five structures completed during the Oregon Coast Bridges Project in 1936.

The bridge is 1,568 feet long and includes a central 140-foot double-leaf steel deck truss draw span flanked by a pair of 154-foot reinforced-concrete through tied arches. The roadway is 27 feet curb-to-curb, with two travel lanes. Vertical clearance through the arch spans is 16'-4". Twenty reinforced-concrete deck girder spans form the approaches to the tied arches. Eight are on the north side and twelve on the south side, ranging from 42 to 70 feet in length. The bridge has 3 foot-wide sidewalks along its entire length on both sides.

The draw span's two leaves are hinged on 14-inch trunnions. They separate in the middle of the span and swing upward and away from each other. This operation is powered by two 15-horsepower motors. Horizontal clearance through the open span is 110 feet. When closed, the vertical clearance is 33 feet above the river. The original deck across the bascule span was Port Orford cedar wood planking paved with asphalt.¹

The two main piers are massive concrete structures with pits at their tops. As the bascule opens, large concrete counterweights descend into these pits. A concrete operator's house is located on tops of the piers at each of the four corners of the draw span. These contain the control mechanisms and general storage. They are 24 feet long by 9 feet wide and are topped by domed roofs. The door and window sashes are metal.²

The draw span is flanked on both sides by two reinforced-concrete through tied arches, each 154 feet long. These arches are open spandrel, and have curved sway bracing. The portal bracing bears a decorative winged cartouche in the center. Vertical clearance through these arches is 16'-4", and the horizontal clearance is 26'-11". The lower chords, or arch ties, are four eye-bars anchored to the concrete arch by being pinned to I-beams. These I-beams are buried along the axis of the arch, anchored by angle-iron lugs. The arches were constructed with Considère-type hinges. These are points in the rib where the reinforcing steel is not connected and the concrete not poured to full section until after the dead load has been applied to the arch. The purpose of this method is to reduce stress on the entire arch when the dead load is applied. The decks are carried on floor beams supported by hangers. The hangers and bottom chord bars were not encased in concrete until after the dead load was applied. This was done to prevent elongation and cracking of the concrete in the hangers. The hangers rest on structural steel shoes. The shoes on one end of the arch are on rollers. On the outer side of each of the arch ribs are located concrete spires, the tops of which are similar in design to those of the pier houses.³

On the Siuslaw River Bridge, McCullough combined the vocabularies of classical and Gothic-style elements with the popular Art Deco and Moderne influences of the late 1920s and the 1930s. Twin tiered pylons are located at the ends of the bridge. Zigzag inset panels are found on all four sides and are below grilles that cover lights that demarcate entry to the bridge during nighttime hours and in fog. Rising in a stepped manner, these pylons are capped with stylized domes, topped with minarets. Likewise, slender tiered pylons, capped with minarets mark entry to the tied arches. Their verticalness makes them fine examples of the Art Deco style. The main piers were scored to imitate laid cut stone blocks. The operator's houses rest on top of the piers and are capped with elongated sunburst-decorated onion domes and, like

¹O. C. Chase, "Design of Coast Highway Bridges," *Civil Engineering* 6 (October 1936): 648, 651; R. H. Baldock, "Bridge Builders' Secrets," *Oregon Motorist* 16, no. 4 (May 1936): 9.

²Chase, "Design of Coast Highway Bridges," 9; Baldock, "Bridge Builders' Secrets," 9; ODOT, Bridge Section, drawing #4789.

³Chase, "Design of Coast Highway Bridges," 649; ODOT, Environmental Section, Bridge File #1821E, "Engineering Antiquities Survey," November 1982, p. 72.

United States Department of the Interior
National Park ServiceNATIONAL REGISTER OF HISTORIC PLACES
CONTINUATION SHEETSection 7 Page 7Siuslaw River Bridge No. 01821
Name of PropertyLane County, Oregon
County and State

the entry pylons, are topped with minarets.

The bridge's concrete bents are tiered and ornamented in the Art Deco style with vertical detailing. Likewise column surfaces are broken by scoring. However, the web walls between main pier legs were cut away in the form of Gothic arches with sunburst rays. In addition, ornamental elbow brackets mounted at the top of the spandrel columns supporting and protruding beyond the sidewalks. The sidewalk balustrades include panels comprising small, stylized Gothic arches, which repeat the form seen in the piers and bents. They are stepped back in the Art Deco/Moderne philosophy to create shadow lines and increase visual interest. Concrete portal braces with scored decorative cartouches and fluted slender deck hangers complete the artistic ensemble on the concrete arch spans.

Acting State Bridge Engineer Glenn S. Paxson supervised construction of the five coastal bridges as Conde B. McCullough had taken a leave of absence to work on bridges in Central America. A contract was awarded to the Mercer-Fraser Company of Eureka, California. Work commenced on the Siuslaw River Bridge on 5 August 1934 and the structure was opened to traffic on 1 April 1936. One hundred forty men were employed each week with a weekly payroll of \$3,000. Each man worked thirty hours per week in order to employ as many men as possible. The construction required excavation of 3,800 cubic yards of material, 40,800 lineal feet of piling, 10,000 cubic yards of concrete, 200 tons of structural steel, and 1,000 tons of reinforcing steel. The cost was \$527,000.⁴

The Siuslaw River Bridge was the first of the five Public Works Administration bridges completed on the Oregon Coast Highway. Crowds descended upon Florence on Saturday, 23 May 1936 to participate in dedication festivities. Miss Gail Darling was crowned "Queen Rhododendron VIII" to rule over the two-day celebration. A "Queen's Ball" capped the first day's activities. On Sunday, the Queen christened the bridge by smashing a bottle of Canada Dry ginger ale on one of the entry pylons. Several booster organizations, including the "Red Devils" from Devil's Lake; and the North Bend, Corvallis, and Eugene chambers of commerce and local school bands also participated in the event. Former Governor A. W. Norblad delivered the principal dedicatory address Sunday morning, after which Queen Rhododendron christened the bridge with a bottle of Siuslaw River water. The annual Florence seafood dinner and afternoon dancing followed. It was estimated that 5,000 to 7,000 gathered in Florence to participate in the celebration.⁵

For the most part maintenance on the Siuslaw River Bridge has consisted of routine cleaning, painting and minor repairs. The wood plank deck of the draw span was used until the mid-1970s when continuous patching made it unserviceable. In 1977, it was replaced by a steel grid deck.⁶

⁴Baldock, "Bridge Builders' Secrets," 9.

⁵A. L. Lindbeck, "Siuslaw Span Dedication On This Weekend," *Portland Oregon Journal*, 24 May 1936; Richard Johnston, "Bottle Bursts, Siuslaw Bridge Christened by Queen Rhododendron," *Eugene News*, May 25, 1936; A. L. Lindbeck, "Great Throng Views Bridge Dedication," *Portland Oregon Journal*, May 25, 1936.

⁶ODOT Bridge Section, Maintenance File #1821E, Maintenance Report, prepared by J. Wood, October 26, 1976.

United States Department of the Interior
National Park ServiceNATIONAL REGISTER OF HISTORIC PLACES
CONTINUATION SHEETSection 8 Page 8Siuslaw River Bridge No. 01821

Name of Property

Lane County, Oregon

County and State

Narrative Statement of Significance

The Siuslaw River Bridge No. 01821 is being nominated under the C. B. McCullough Major Oregon Coast Highway Bridges Multiple Property Submission. It is significant under National Register criterion C because it embodies the distinctive characteristics of a type, period, and method of construction for mid-twentieth-century reinforced-concrete arch bridge technology. Just as important, it is significant under criterion C as the work of a master, Conde B. McCullough, Oregon state bridge engineer from 1919 to 1936. The bridge has a strong thematic association with the design and construction of several other major steel and reinforced-concrete bridges designed by McCullough and erected along the Oregon Coast Highway No. 9 (US 101) in the 1920s and 1930s. The bridge is also significant under criterion A for its association with construction of the Oregon Coast Highway, which eventually ran the length of Oregon and connected with adjacent segments in California and Washington. The road would not have been complete without eleven major bridges, including the Siuslaw River Bridge, and many other spans.

Europeans migrated to the lower Siuslaw River in the 1880s and by 1893 incorporated the town of Florence, reportedly named after a sailing ship that wrecked nearby. Sawmills and salmon canneries established in Florence in the late nineteenth century caused the local economy to blossom. Coastal steamers regularly shipped canned salmon from the Siuslaw River estuary at Florence. The Pacific Great Western Railway's construction of a line from Eugene to Florence in 1911-12, which continued south to Reedsport and Coos Bay, also stimulated the local economy. Construction of the Oregon Coast Highway in the 1920s bypassed primitive local roads and connected Florence with other communities along the Oregon coast.⁷

The Siuslaw River Bridge possesses national significance under criterion C as one of the six major bridges that McCullough constructed on the Oregon Coast Highway between 1931 and 1936 and spanned the remaining barriers to efficient travel along the route—three bays and three river estuaries that relied on an outmoded ferry service. (The others were the Alsea Bay Bridge at Waldport, the Yaquina Bay Bridge at Newport, the Umpqua River Bridge at Reedsport, the Coos Bay (McCullough) Bridge at Coos Bay, and the Rogue River Bridge at Gold Beach.) Completion of these bridges (one in 1932 and five in 1936) is considered the dividing line between the period of relative isolation and dependence on sea transportation for many of Oregon's coastal communities and their newfound association with each other along this ribbon of asphalt, known as US 101. The Siuslaw River Bridge is the only one of the five PWA coastal bridges with a bascule span. It was the first of the five bridges to be completed as part of the Oregon Coast Bridges Project.⁸

The Siuslaw River Bridge is also significant under criterion C as the work of a master, Oregon State Bridge Engineer, Conde B. McCullough, and due to its thematic association with several other major steel and reinforced-concrete bridges designed by McCullough and erected along the Oregon Coast Highway in the 1920s and 1930s. During his years as State Bridge Engineer, and later as Assistant State Highway Engineer, McCullough authored several books and many technical articles on bridge design and construction. He is significant for his use of innovative bridge technology, and for his visually appealing designs. He attained international recognition for the large-scale structures he designed to span the major rivers and estuaries, and several other thematically-similar concrete arch, beam, and girder structures, along the Oregon Coast Highway.

McCullough's bridges also had in common design themes and elements executed in classical, Gothic, and Art Deco/Moderne styles. They are evident on sidewalk railing balustrades; bracketing; arched curtain walls, entrance pylons, columns, stringers, piers, staircases, and other structural members. Eric N. DeLony, chief of the Historic American Engineering Record, remarked in his book, *Landmark American Bridges*, that this family of spans on the Oregon Coast

⁷Nathan Douthit, *A Guide to Oregon South Coast History: Traveling the Jedediah Smith Trail* (Corvallis: Oregon State University Press, 1999), 176-78.

⁸A. L. Lindbeck, "Great Throng Views Bridge Dedication," *Portland Oregon Journal*, 25 May 1936.

United States Department of the Interior
National Park Service

**NATIONAL REGISTER OF HISTORIC PLACES
CONTINUATION SHEET**

Section 8 Page 9

Siuslaw River Bridge No. 01821
Name of Property

Lane County, Oregon
County and State

Highway "represents some of the best and most innovative concrete and steel bridges in the world."⁹

Interestingly, McCullough once proudly exclaimed that "no architects were retained in connection with the design of the above [coastal] bridges. In other words, both the architectural and engineering design work was done in our bridge designing and drafting rooms." McCullough's sense of space, order, and proportion is evident in the Siuslaw River Bridge, which is truly an example of architecture creating art in mid-20th-century American engineering.¹⁰

The Siuslaw River Bridge is significant under criterion A because of its association with the construction of the Oregon Coast Highway in the 1930s. Completion of the Oregon Coast Highway was a major public works effort in the early and mid-1930s to establish an uninterrupted transportation route from California to Washington. The effort was aided by the Oregon Coast Bridges Project in which the federal Public Works Administration provided funds for the construction of five modern bridges to replace the existing slow, cumbersome ferries that crossed the larger bays, rivers and estuaries. An immediate accomplishment of the route's completion was the construction jobs that it provided to many unemployed workers. In more long-lasting terms, the highway's completion was a major factor in the development of commerce and tourism in Oregon's coastal regions, and it has since become one of the most notable scenic routes in the United States. The Oregon Coast Highway is worthy of its recent designation as a National Scenic Byway.

The Siuslaw River Bridge meets the property type and registration requirements for the C. B. McCullough Oregon Coast Highway Bridges Multiple Property Submission. It was completed during the period of significance (1927-36) on the then current alignment of the Oregon Coast Highway No. 9 (US 101). It was designed by Oregon State Highway Department bridge engineers under the direction of Conde B. McCullough. Its primary or secondary main spans are reinforced-concrete arches. It possesses a high degree of original integrity of design and materials.

⁹Eric DeLony, *Landmark American Bridges*, (New York: American Society of Civil Engineers and Bulfinch Press, 1993), 125-35 (quote, 125).

¹⁰C. B. McCullough to White and Wycoff Manufacturing Company (Holyoke, Massachusetts), 30 April 1946, ODOT Bridge Section files.

United States Department of the Interior
National Park Service

**NATIONAL REGISTER OF HISTORIC PLACES
CONTINUATION SHEET**

Section 9 Page 10

Siuslaw River Bridge No. 01821
Name of Property

Lane County, Oregon
County and State

Major Bibliographic References

- Atly, Elizabeth Shellin. "C. B. McCullough and the Oregon Coastal Bridges Project," TMs, 1977.
- Baldock, R. H. "Bridge Builders' Secrets," *Oregon Motorist* 16, no. 4 (May 1936): 5-12.
- Chase, O. C. "Design of Coast Highway Bridges," *Civil Engineering* 6 (October 1936): 648-51.
- Douthit, Nathan. *A Guide to Oregon South Coast History: Traveling the Jedediah Smith Trail*. Corvallis: Oregon State University Press, 1999.
- Hadlow, Robert W. *Elegant Arches, Soaring Spans: C. B. McCullough, Oregon's Master Bridge Builder*. Corvallis: Oregon State University Press, 2001.
- Johnston, Richard. "Bottle Bursts, Siuslaw Bridge Christened by Queen Rhododendron." *Eugene News*, May 25, 1936.
- Lindbeck, A. L. "Great Throng Views Bridge Dedication." *Portland Oregon Journal*, 25 May 1936.
- "Siuslaw Span Dedication On This Weekend." *Portland Oregon Journal*, 24 May 1936.
- Link, Gary M. "Siuslaw River Bridge, HAER No. OR-58, Report." Historic American Engineering Record, National Park Service, 1990.
- McCullough, C. B. "Five New Spans for Coast Highway." *Astoria Astorian Budget*, 26 February 1934.
- Oregon Department of Transportation. Bridge Section Maintenance File #1821E.
- Oregon State Highway Commission. *Eleventh Biennial Report, for 1933-34*.
- *Twelfth Biennial Report, for 1935-36*.
- Paxson, Glenn S. "Construction of Coast Highway Bridges." *Civil Engineering* 6, no. 10 (October 1936): 651-55.
- Peterson, Ernest W. "Concrete Viaduct Across Siuslaw River Ends Picturesque Old Era; Utility and Beauty in New Coast Span." *Portland Oregon Journal*, 12 April 1936, 6.
- Peterson, Ernest W. "Conquest of Oregon Coast Nears End." *Portland Oregon Journal*, 6 September 1936, s. 4, p. 1.
- "Siuslaw River Bridge," *Oregon Motorist* 8 (May 1936): 9.
- Smith, Dwight A., James B. Norman, and Pieter T. Dykman. *Historic Highway Bridges of Oregon*. Portland: Oregon Historical Society Press, 1989.

**United States Department of the Interior
National Park Service**

**NATIONAL REGISTER OF HISTORIC PLACES
CONTINUATION SHEET**

Section 10 Page 11

Siuslaw River Bridge No. 01821
Name of Property

Lane County, Oregon
County and State

Verbal Boundary Description

The property is described as beginning at the north end of the Siuslaw River Bridge, at mile post 190.98 on the Oregon Coast Highway No. 9, and running 1,568 feet to the south end of the bridge. It is 60 feet wide (30 feet either side of center line on the bridge).

Boundary Justification

The boundary includes property associated historically with the Siuslaw River Bridge.

**United States Department of the Interior
National Park Service**

**NATIONAL REGISTER OF HISTORIC PLACES
CONTINUATION SHEET**

Section 11 Page 12

Siuslaw River Bridge No. 01821
Name of Property

Lane County, Oregon
County and State

Photographs

James B. Norman, Photographer, June 2003
(Original negatives housed at Oregon Department of Transportation, Salem, Oregon)

Photographic Description

View No.	Description
1	General perspective view of the Siuslaw River Bridge, view looking northwest.
2	General perspective view of the bridge, view looking north.
3	General view of the bridge, view looking southeast.
4	General view of the main spans view looking southeast.
5	General view of the main spans, view looking southeast.
6	General view of the main spans, view looking south.

Leslie Schwab, Photographer, July 2004
(Original negatives housed at Oregon Department of Transportation, Salem, Oregon)

Photographic Description

View No.	Description
7	Detail view of the decorative concrete pylons, view looking north.
8	Detail view of the concrete through arch portals and portal obelisks, view looking north.
9	Detail view of the draw span operator's house/pylon.
10	Detail view of the operator's house/pylon, view looking northeast.
11	Detail view of the portal obelisk, view looking east.
12	Detail view of the entrance pylon, view looking northeast.
13	Detail view of the bridge plaque, view looking east.

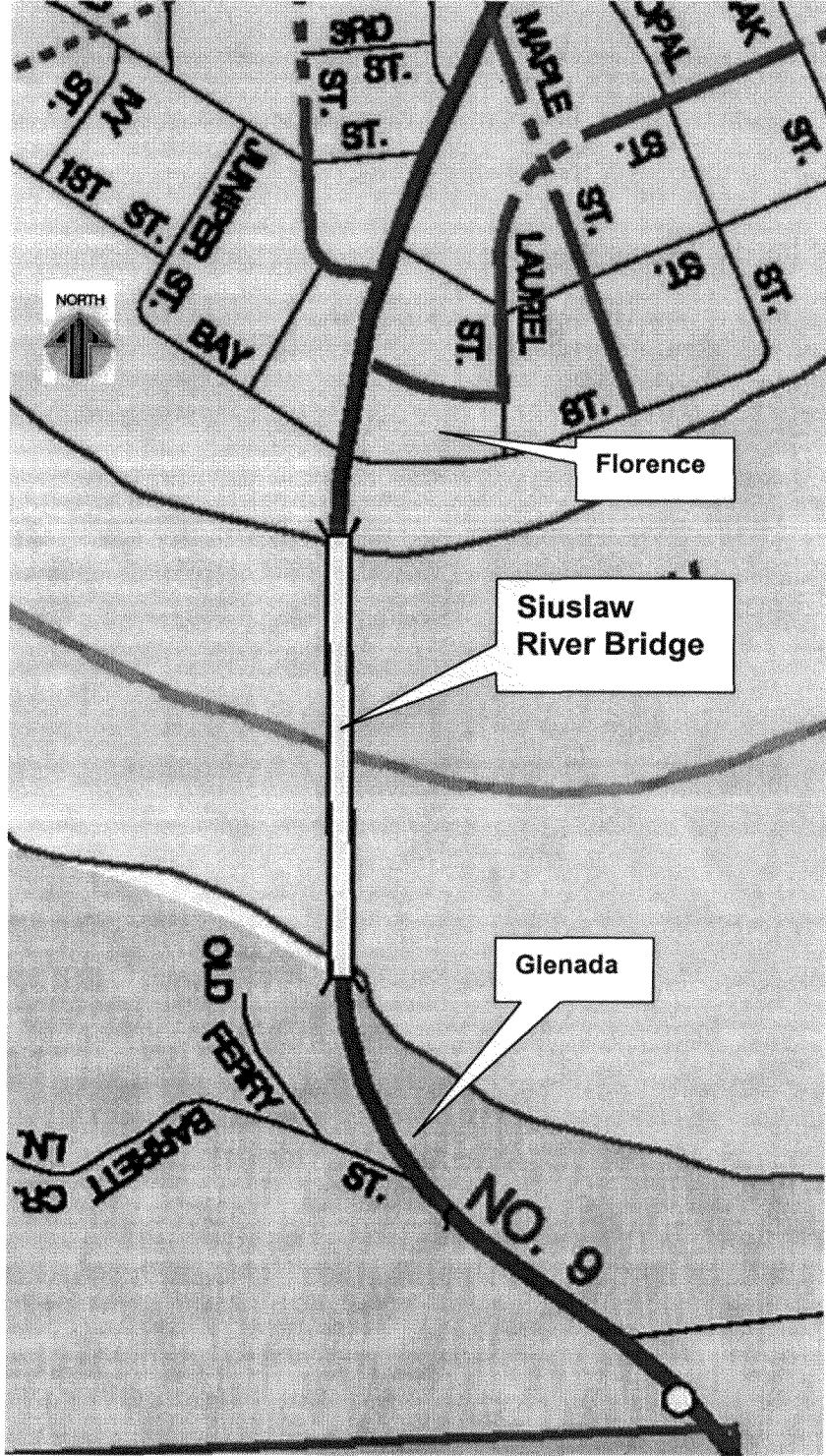

**Siuslaw River Bridge No. 01821
MP 190.98, Oregon Coast Highway No. 9
Florence, Lane County, Oregon**

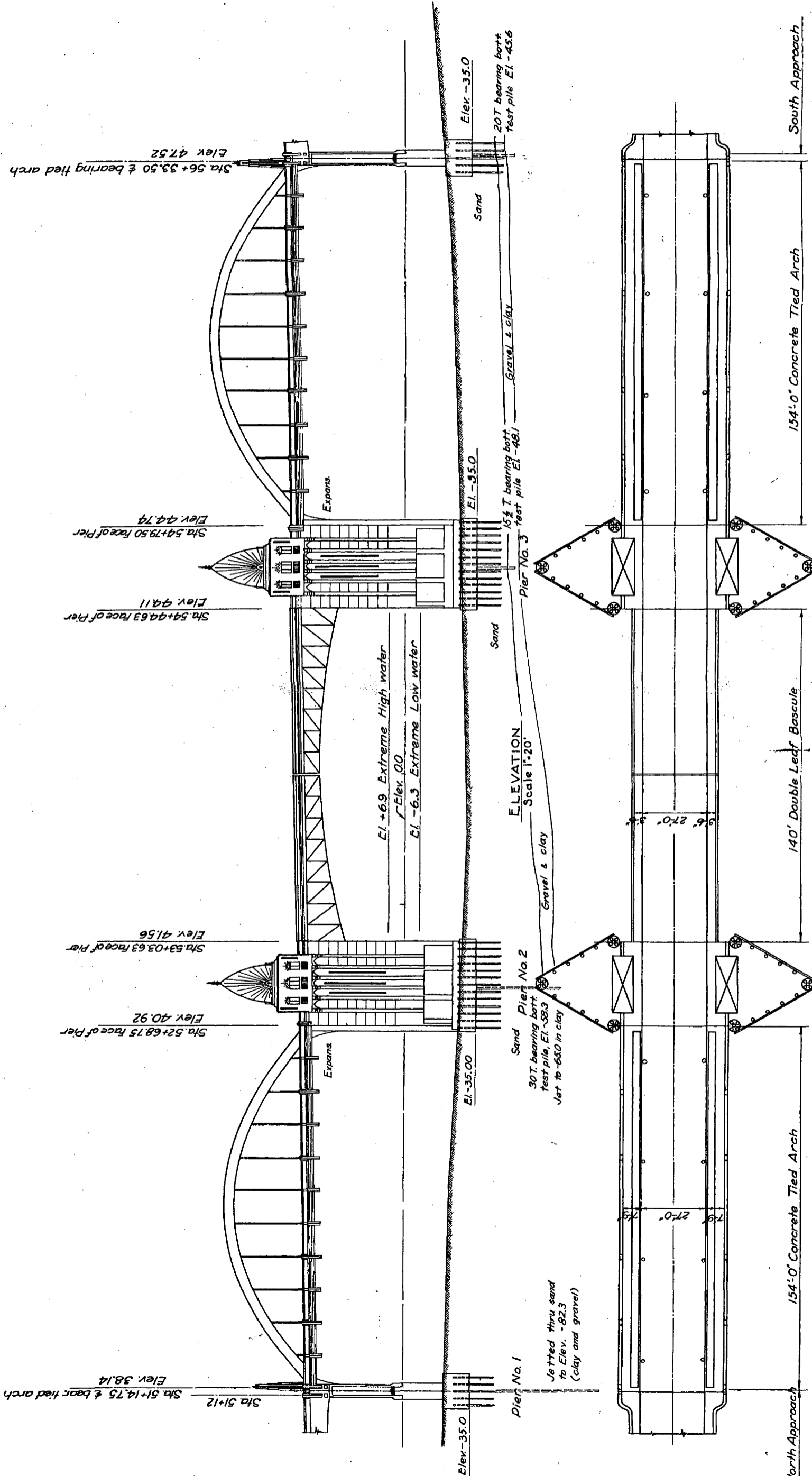

ELEVATION
Scale 1"=20'

DECK PLAN
Scale 1"=20'

OREGON
STATE HIGHWAY COMMISSION
SIUSLAW RIVER BRIDGE
LAYOUT MAIN SPANS
SCALE AS NOTED DRAWN BY CCS TRACED BY RAW
CALC. BK. NO. 129 CHECKED BY BRIDGE NO. 4751
BRIDGE NO. 1821

Approved:
[Signature]
Bridge Engineer
State Highway Engineer

Revised Jan. 5, 1934
Revised Apr. 4, 1935

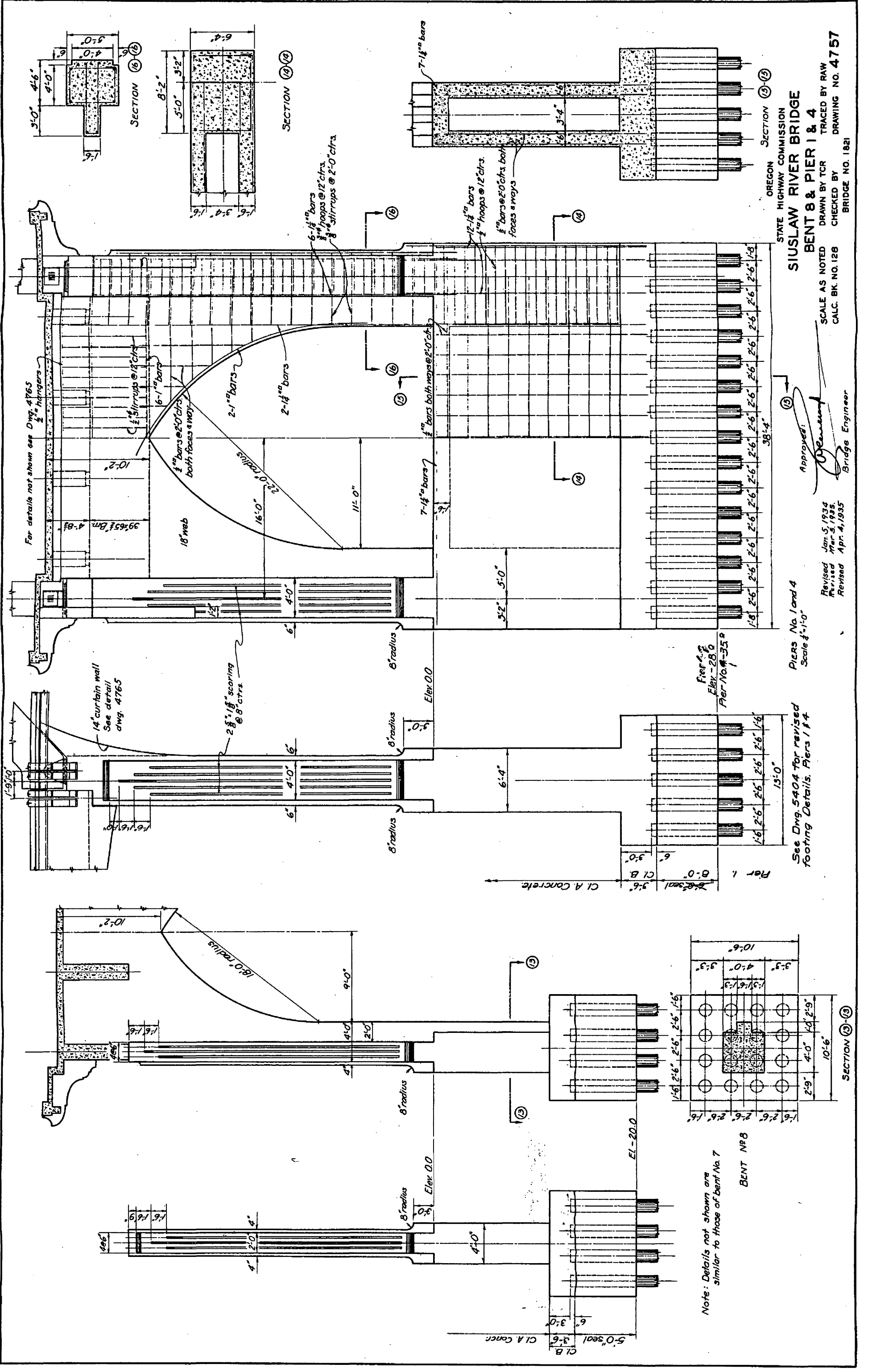

OREGON STATE HIGHWAY COMMISSION
SIUSLAW RIVER BRIDGE
BENT 8 & PIER 1 & 4
 DRAWN BY TCR
 CHECKED BY
 BRIDGE NO. 1821

SCALE AS NOTED
 CALC. BK. NO. 128
 DRAWING NO. 4757

Approved: *[Signature]*
 Bridges Engineer

Revised Jan. 5, 1934
 Revised Mar. 5, 1935
 Revised Apr. 4, 1935

Piers No. 1 and 4
 Scale 1/2" = 1'-0"

See Dwg. 5404 for revised footing details. Piers 1 & 4

Note: Details not shown are similar to those of bent No. 7

BENT No 8

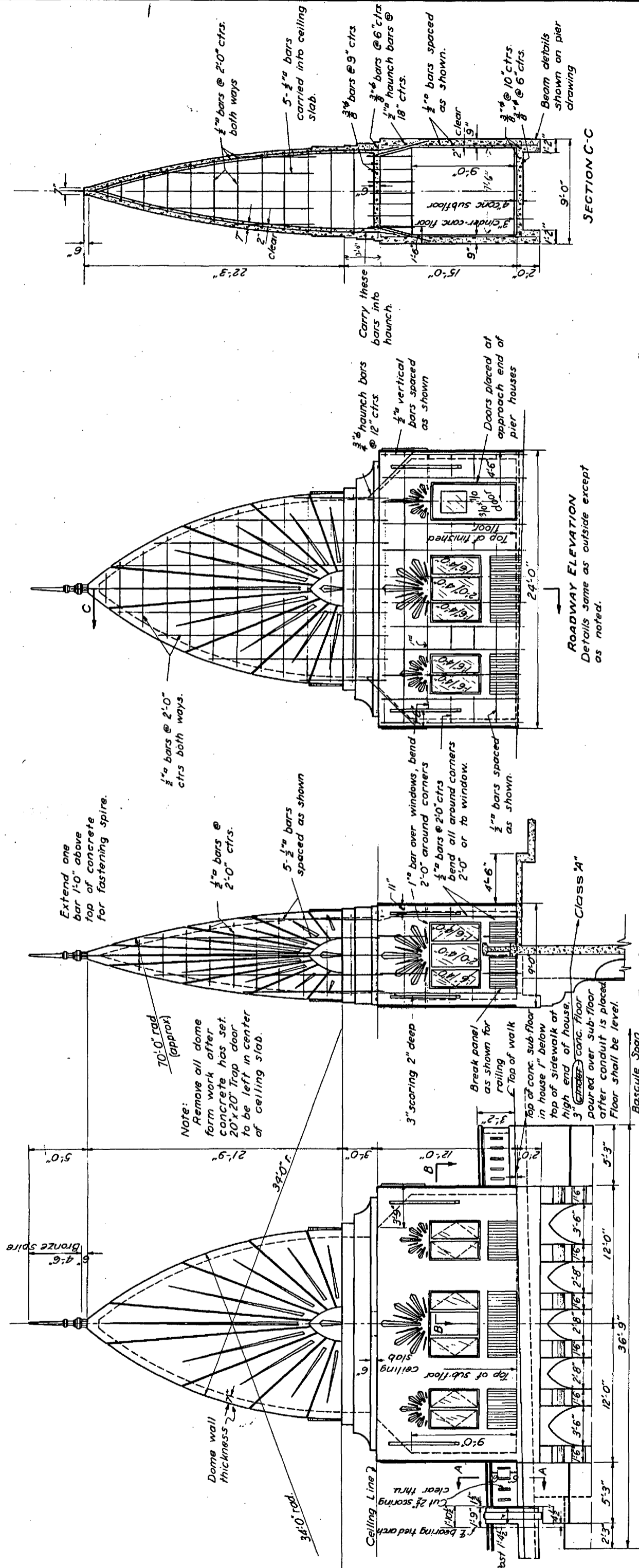

OUTSIDE ELEVATION
Scale $\frac{1}{4}''=1'-0''$

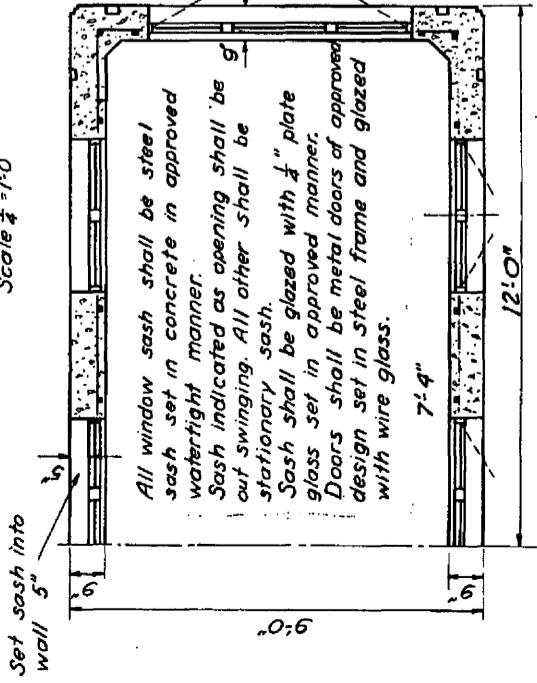

SECTION B-B
Scale $\frac{1}{2}''=1'-0''$

END ELEVATION
Both ends Similar

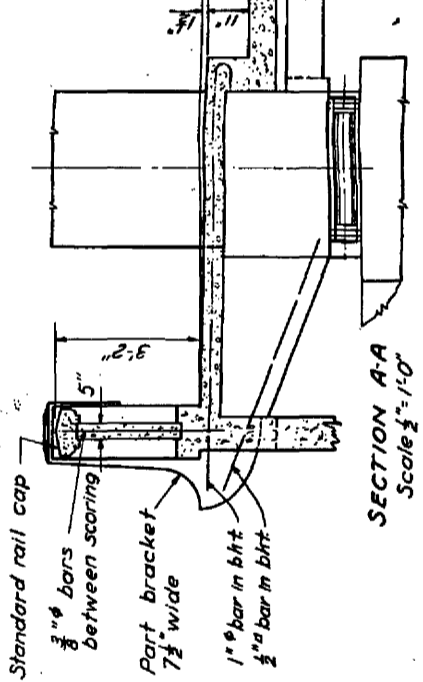

SECTION A-A
Scale $\frac{1}{2}''=1'-0''$

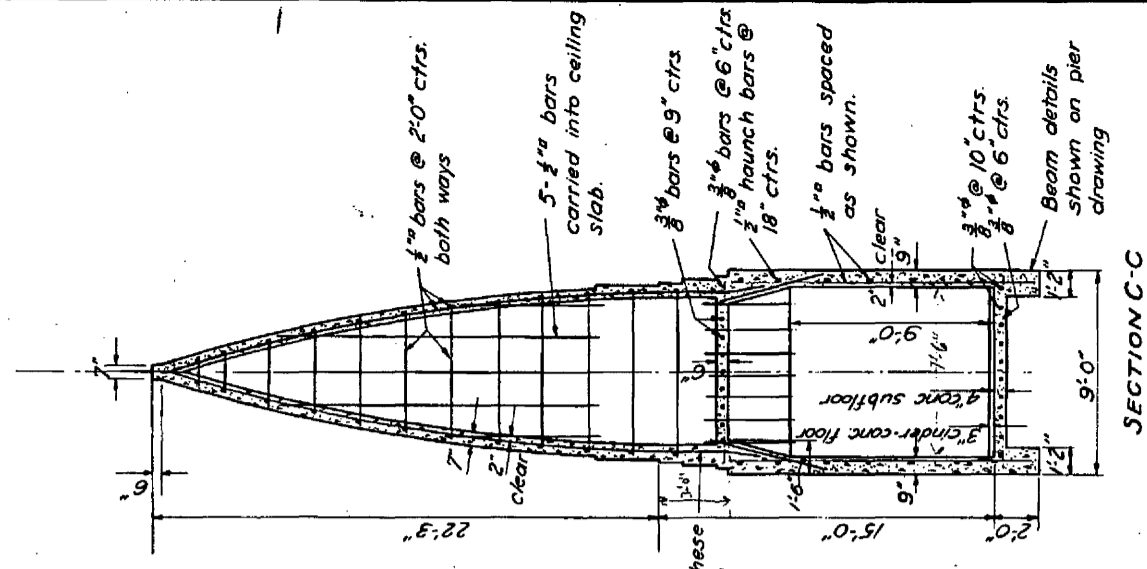

SECTION C-C

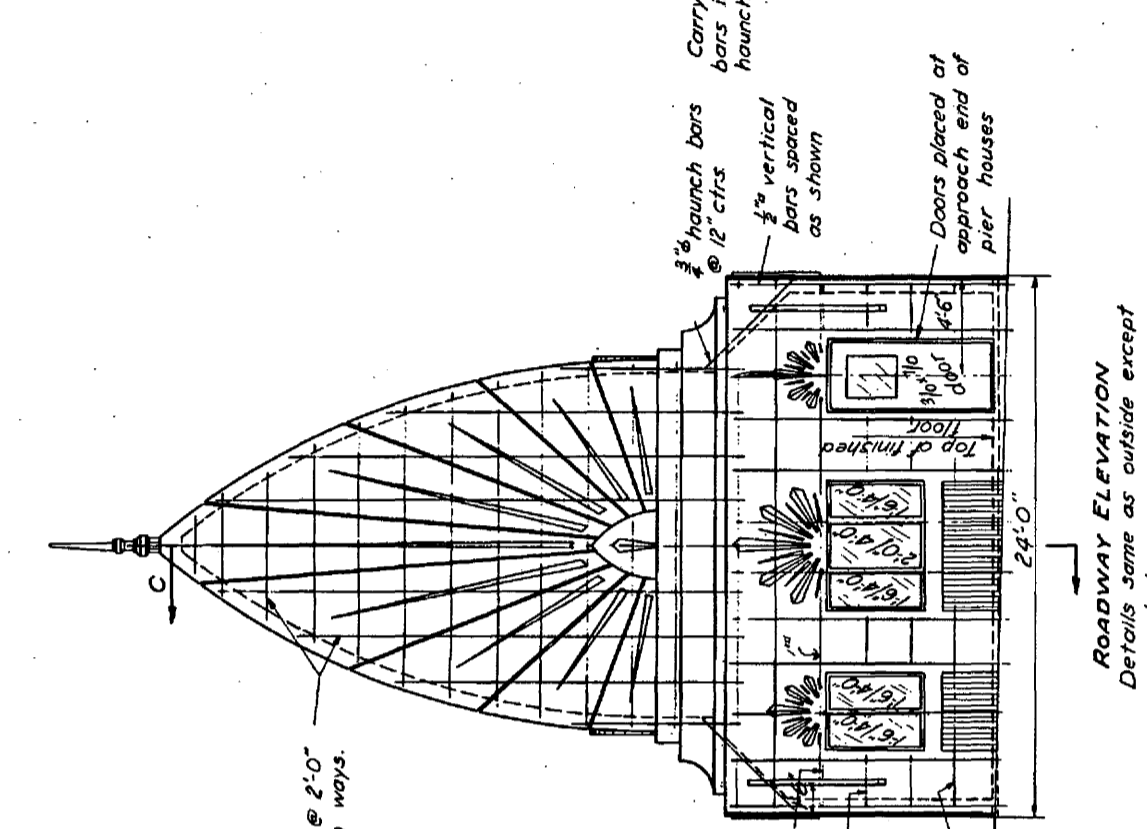

ROADWAY ELEVATION
Details same as outside except as noted.

OREGON
STATE HIGHWAY COMMISSION
SIUSLAW RIVER BRIDGE
DETAIL OF PIER HOUSES
SCALE AS NOTED DRAWN BY CCS TRACED BY AEJ
CALC. BK. NO. 129 CHECKED BY
BRIDGE NO. 1821 DRAWING NO. 4789

Revised Jan. 6, 1934
Revised Mar. 27, 1935
Revised Feb. 18, 1936

Approved:

[Signature]
Bridge Engineer

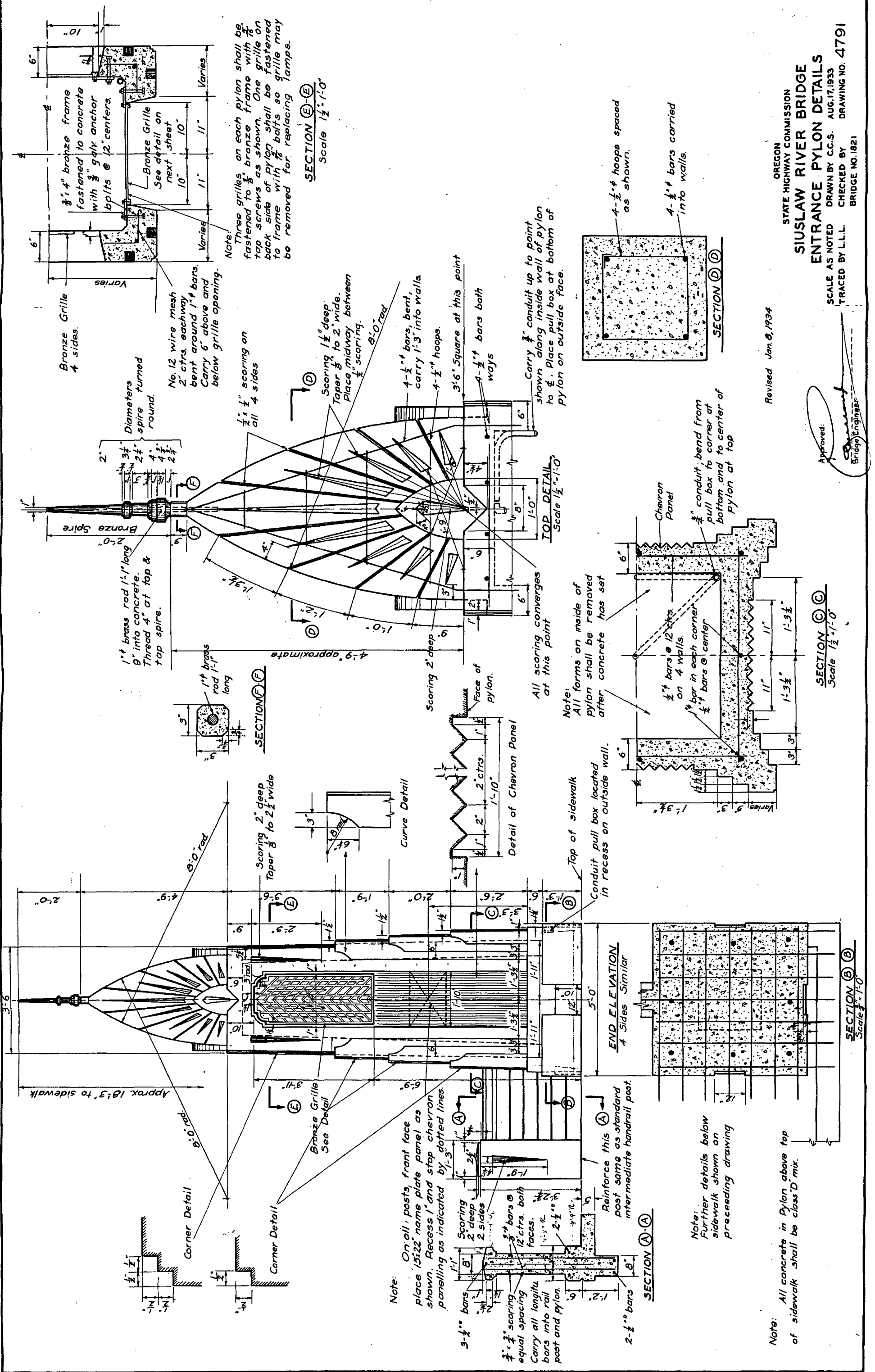

Revised Jan. 8, 1934

OREGON
STATE HIGHWAY COMMISSION
SIUSLAW RIVER BRIDGE
ENTRANCE PYLON DETAILS
SCALE AS NOTED DRAWN BY C.C.S. AUG. 17, 1933
TRACED BY L.L.L. CHECKED BY
BRIDGE NO. 1821

Approved:
Bridge Engineer