

56-2036

United States Department of the Interior
National Park Service

National Register of Historic Places Registration Form

This form is for use in nominating or requesting determinations for individual properties and districts. See instructions in National Register Bulletin, *How to Complete the National Register of Historic Places Registration Form*. If any item does not apply to the property being documented, enter "N/A" for "not applicable." For functions, architectural classification, materials, and areas of significance, enter only categories and subcategories from the instructions. Place additional certification comments, entries, and narrative items on continuation sheets if needed (NPS Form 10-900a).

1. Name of Property

Historic name Miller, Joseph M., Mausoleum

Other names/site number N/A

Name of related Multiple Property Listing N/A

2. Location

Street & number .8 mile north of jct. MO HWY 131 and 2nd Street n/a not for publication

City or town Holden n/a vicinity

State Missouri Code MO County Johnson Code 101 Zip code 64040

3. State/Federal Agency Certification

As the designated authority under the National Historic Preservation Act, as amended,

I hereby certify that this x nomination request for determination of eligibility meets the documentation standards for registering properties in the National Register of Historic Places and meets the procedural and professional requirements set forth in 36 CFR Part 60.

In my opinion, the property x meets does not meet the National Register Criteria. I recommend that this property be considered significant at the following level(s) of significance:

 national statewide x local

Applicable National Register Criteria: A B x C D

 Deputy SIAA
Signature of certifying official/Title

DEC 07 2017
Date JP 12/06/17

Missouri Department of Natural Resources
State or Federal agency/bureau or Tribal Government

In my opinion, the property meets does not meet the National Register criteria.

Signature of commenting official _____ Date _____

Title _____ State or Federal agency/bureau or Tribal Government _____

4. National Park Service Certification

I hereby certify that this property is:

entered in the National Register determined eligible for the National Register

determined not eligible for the National Register removed from the National Register

other (explain:)

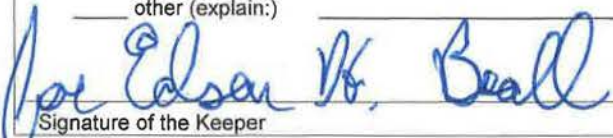
Signature of the Keeper

1.29.18
Date of Action

Miller, Joseph M., Mausoleum
Name of Property

Johnson County, Missouri
County and State

5. Classification

Ownership of Property
(Check as many boxes as apply.)

Category of Property
(Check only **one** box.)

Number of Resources within Property
(Do not include previously listed resources in the count.)

<input checked="" type="checkbox"/>	private
<input type="checkbox"/>	public - Local
<input type="checkbox"/>	public - State
<input type="checkbox"/>	public - Federal

<input checked="" type="checkbox"/>	building(s)
<input type="checkbox"/>	district
<input type="checkbox"/>	site
<input type="checkbox"/>	structure
<input type="checkbox"/>	object

<u>Contributing</u>	<u>Noncontributing</u>	
1	1	buildings
0	0	sites
0	0	structures
0	0	objects
1	1	Total

Number of contributing resources previously listed in the National Register

0

6. Function or Use

Historic Functions
(Enter categories from instructions.)

FUNERARY/ Cemetery

Current Functions
(Enter categories from instructions.)

VACANT/ Not in use

7. Description

Architectural Classification
(Enter categories from instructions.)

LATE 19TH AND 20TH CENTURY REVIVALS/
Late Gothic Revival

Materials
(Enter categories from instructions.)

foundation: Concrete
walls: Concrete
Steel
roof: Concrete
other: Stone

NARRATIVE DESCRIPTION ON CONTINUATION PAGES

Miller, Joseph M., Mausoleum
Name of Property

Johnson County, Missouri
County and State

8. Statement of Significance

- A Property is associated with events that have made a significant contribution to the broad patterns of our history.
- B Property is associated with the lives of persons significant in our past.
- C Property embodies the distinctive characteristics of a type, period, or method of construction or represents the work of a master, or possesses high artistic values, or represents a significant and distinguishable entity whose components lack individual distinction.
- D Property has yielded, or is likely to yield, information important in prehistory or history.

Criteria Considerations
(Mark "x" in all the boxes that apply.)

Property is:

- A Owned by a religious institution or used for religious purposes.
- B removed from its original location.
- C a birthplace or grave.
- D a cemetery.
- E a reconstructed building, object, or structure.
- F a commemorative property.
- G less than 50 years old or achieving significance within the past 50 years.

STATEMENT OF SIGNIFICANCE ON CONTINUATION PAGES

9. Major Bibliographical References

Bibliography (Cite the books, articles, and other sources used in preparing this form.)

Previous documentation on file (NPS):

- preliminary determination of individual listing (36 CFR 67 has been requested)
- previously listed in the National Register
- previously determined eligible by the National Register
- designated a National Historic Landmark
- recorded by Historic American Buildings Survey # _____
- recorded by Historic American Engineering Record # _____
- recorded by Historic American Landscape Survey # _____

Primary location of additional data:

- State Historic Preservation Office
- Other State agency
- Federal agency
- Local government
- University
- Other

Name of repository: Johnson County Historical Society

Historic Resources Survey Number (if assigned): _____

Areas of Significance

Architecture

Period of Significance

1917-1937

Significant Dates

1917

Significant Person

(Complete only if Criterion B is marked above.)

N/A

Cultural Affiliation

N/A

Architect/Builder

Builder/ Miller, Joseph M.

Miller, Joseph M., Mausoleum
Name of Property

Johnson County, Missouri
County and State

10. Geographical Data

Acreeage of Property 1.4

Latitude/Longitude Coordinates

Datum if other than WGS84: _____
(enter coordinates to 6 decimal places)

1 38.730246° -93.993103° 3 _____
Latitude: Longitude: Latitude: Longitude:

2 _____ 4 _____
Latitude: Longitude: Latitude: Longitude:

UTM References

(Place additional UTM references on a continuation sheet.)

_____ NAD 1927 or _____ NAD 1983

1 _____
Zone Easting Northing

3 _____
Zone Easting Northing

2 _____
Zone Easting Northing

4 _____
Zone Easting Northing

Verbal Boundary Description (On continuation sheet)

Boundary Justification (On continuation sheet)

11. Form Prepared By

name/title Andrea Herries (Edits by Debbie Sheals and Carl Cranfill)
organization Historic Preservation Consulting date November 21, 2017
street & number 29 South Ninth St. #210 telephone 573-874-3779
city or town Columbia state MO zip code 65201
e-mail debsheals@gmail.com

Additional Documentation

Submit the following items with the completed form:

- **Maps:**
 - A **USGS map** (7.5 or 15 minute series) indicating the property's location.
 - A **Sketch map** for historic districts and properties having large acreage or numerous resources. Key all photographs to this map.
- **Continuation Sheets**
- **Photographs**
- **Owner Name and Contact Information**
- **Additional items:** (Check with the SHPO or FPO for any additional items.)

Paperwork Reduction Act Statement: This information is being collected for applications to the National Register of Historic Places to nominate properties for listing or determine eligibility for listing, to list properties, and to amend existing listings. Response to this request is required to obtain a benefit in accordance with the National Historic Preservation Act, as amended (16 U.S.C.460 et seq.).

Miller, Joseph M., Mausoleum
Name of Property

Johnson County, Missouri
County and State

Estimated Burden Statement: Public reporting burden for this form is estimated to average 18 hours per response including time for reviewing instructions, gathering and maintaining data, and completing and reviewing the form. Direct comments regarding this burden estimate or any aspect of this form to the Office of Planning and Performance Management, U.S. Dept. of the Interior, 1849 C. Street, NW, Washington, DC.

Photographs

Submit clear and descriptive photographs. The size of each image must be 1600x1200 pixels (minimum), 3000x2000 preferred, at 300 ppi (pixels per inch) or larger. Key all photographs to the sketch map. Each photograph must be numbered and that number must correspond to the photograph number on the photo log. For simplicity, the name of the photographer, photo date, etc. may be listed once on the photograph log and doesn't need to be labeled on every photograph.

Photo Log:

Name of Property: Joseph M. Miller Mausoleum

City or Vicinity: Holden

County: Johnson State: Missouri

Photographer: Debbie Sheals (4-8, 10, 12-14, 16-18, 21) and Carl Cranfill (1-3, 9, 11, 15, 19-20, 22)

Date

Photographed: April 25, 2017 and June 21, 2017 through July 27, 2017

Description of Photograph(s) and number, include description of view indicating direction of camera:

- 1 of 22: Southeast Corner. Camera looking northwest.
- 2 of 22: Façade, East side. Camera looking west.
- 3 of 22: North Side. Camera looking south.
- 4 of 22: Cornice and Roof Detail at Upper Northeast Corner. Camera looking northwest.
- 5 of 22: Window Detail, North Side. Camera looking south.
- 6 of 22: Northwest Corner. Camera looking southeast.
- 7 of 22: Cornice and Upper Wall Detail, Northwest Corner. Camera looking southeast.
- 8 of 22: Back, West Side. Camera looking east.
- 9 of 22: South Side. Camera looking north.
- 10 of 22: Domed Cupola with Observation Platform and Stairs, Roof. Camera looking southeast.
- 11 of 22: Front Crypt Room, First Floor. Camera looking northwest.
- 12 of 22: Lower East Wall Detail, First Floor North Hall. Camera looking east.
- 13 of 22: Back Crypt Room, First Floor. Camera looking north.
- 14 of 22: North Hall, Second Floor. Camera looking east.
- 15 of 22: Reception Room, Second Floor. Camera looking southeast.
- 16 of 22: Reception Room, Second Floor. Camera looking northwest.
- 17 of 22: South Hall, Second Floor. Camera looking east.
- 18 of 22: Stairs to Cupola and Roof, Museum Room, Second Floor. Camera looking north.
- 19 of 22: Museum Room, Second Floor. Camera looking southwest.
- 20 of 22: Ceiling Detail, Museum Room, Second Floor. Camera looking up.
- 21 of 22: Interior Window Detail, Museum Room, Second Floor. Camera looking southwest.
- 22 of 22: Privy, Southwest of Mausoleum. Camera looking west.

Miller, Joseph M., Mausoleum

Johnson County, Missouri

Name of Property

County and State

Figure Log:

Include figures on continuation pages at the end of the nomination.

1. Aerial photo map from Google Earth, with a scale bar. Accessed July 24, 2017.
2. Aerial photo map of the area, from Google Earth with Coordinates. Accessed July 24, 2017.
3. Site Map.
4. Photo ca. 1970 of horse and rider, low stone wall and south side of mausoleum on Miller property.
5. First Floor Plan.
6. Second Floor Plan.
7. Photo ca. 1881 of Laura Alice Miller, Fred Miller, Joseph Marion Miller.
8. Photo collage ca. 1934 with Joseph M. Miller and images of the mausoleum.
9. Types of wall forms for concrete construction.
10. Diagram for correct placement of metal reinforcement in girder construction.
11. Cover of *Concrete Monuments, Mausoleums and Burial Vaults*.
12. Diagram for molding indented, inlaid and projecting letters as shown in *Concrete Monuments, Mausoleums and Burial Vaults*.
13. A. Burial-Crypt, Patent 858.070, June 25, 1907.
B. Image of crypt venting system from Joseph M. Miller Mausoleum, Front Crypt Room.

National Register of Historic Places
Continuation Sheet

Section number 7 Page 1

Miller, Joseph M., Mausoleum
Name of Property
Johnson County, Missouri
County and State
n/a
Name of multiple listing (if applicable)

Summary:

The Miller Mausoleum is located 8/10th of one mile north of the junction of Missouri HWY 131 and 2nd Street near the town of Holden, in Johnson County, Missouri. It is a two-story mausoleum with a vernacular adaptation of the Gothic Revival style, constructed entirely of reinforced concrete. Retired teacher and farmer Joseph Marion Miller began work on the building in 1917 and he spent the next twenty years enlarging and improving it. The mausoleum is located in a rural area, surrounded by cultivated farm fields and patches of forested land. It occupies a 1.4 acre site that adjoins Missouri Highway 131 to the east. The building sits close to the highway, facing east. It is surrounded by open lawns that are dotted with mature trees. The only other resource on the property is a small frame privy that was constructed ca.1980. The privy is a non-contributing building, and the mausoleum is a contributing building. Miller worked on the building in stages from 1917 to the late 1930s. The period of significance for the property begins with the onset of construction, 1917, and ends in 1937 when Miller established a trust for the future care of the completed building, which indicated he considered it to be complete. The Mausoleum building is generally square in plan, with a projecting entry bay that has monumental square pillars, covered porches at the first and second stories, and a tall stepped front parapet. A nameplate with block letters that read "MILLER" is centered in the upper façade. There is a wide front stairway to the second story porch, which has a concrete floor and an arcade formed of pointed arches. The projecting front bay is part of the original core of the building, which was begun in 1917 and completed ca. 1918. Miller spent nearly two additional decades finishing the interior and constructing a large addition which wraps around the sides and back of the original core. Both sections of the building have stuccoed concrete walls that are between two and three feet thick; most of the walls in the front section have square corner piers which extend above the roof line. The walls are all lined with narrow pointed-arch window openings. The flat roof is edged with parapets on all sides, and there are rows of evenly spaced, lancet shaped indentations at the second floor cornice line. A domed cupola centrally located on the roof is topped with a small observation deck. The first floor of the interior contains crypt rooms that hold a total of forty burial vaults, and there are two open gathering spaces on the second floor. The building is intact inside and out, and in fair condition. There have been no changes to the exterior form or footprint of the building, and exterior ornamentation and patterns of fenestration are intact. The most notable exterior alteration involved the front pillars, which have been encased in an extra layer of concrete to address structural issues, but that change does not overly detract from the design and integrity of the building. Two pillars were encased in the 1970s and the remaining two in the summer of 2017. Interior spaces remain much as they were in the 1930s. The building strongly conveys original qualities of workmanship and feeling, its materials and design are mostly unchanged, and it remains in its original setting.

National Register of Historic Places
Continuation Sheet

Section number 7 Page 2

Miller, Joseph M., Mausoleum
Name of Property
Johnson County, Missouri
County and State
n/a
Name of multiple listing (if applicable)

Elaboration

Setting:

The Joseph M. Miller Mausoleum is located approximately 8/10th of a mile north of the town of Holden, on the west side of Missouri Highway 131. (Figure 1, Photo 1) It occupies a level 1.4 acre site that measures 250 feet by 250 feet. (Figures 2, 3) The property is located in a rural area, with large parcels of open land than contains a mix of cultivated fields and forestland. (Figure 1) The nominated property covers a 250 foot square section of land on which the mausoleum is set, and is located in the northeast corner of a 15.69-acre parcel that has been in the Miller family since 1915. The 250 foot square parcel is based upon instructions contained in the "Joseph M. Miller Trust".¹ The nominated parcel is bound to the north by a gravel road that provides access to properties located west of Highway 131; a mix of open land and farm fields is located to the south and east, and the forested land to the west contains a large farm pond.

The mausoleum sits near the east edge of the nominated property, less than thirty feet from the shoulder of Highway 131. The area immediately surrounding the mausoleum includes mowed lawns and a few mature trees. Within the site boundaries is a small frame privy, located southwest of the mausoleum, and a concrete pad to the northwest. The small privy has frame walls covered with plywood paneling, and a gable roof finished with asphalt shingles. It is in very poor condition. The building measures approximately nine feet by seven feet, and a dividing center wall allows for two stalls. The concrete pad is the only remaining part of an open picnic shelter. The privy and picnic shelter were built by a local civic group in the 1980s, after the period of significance. They have not been used for many years and are in very poor condition. (Photo 22, Figure 3) The privy is a non-contributing building; the concrete pad from the shelter is not included in the resource count.

General Form:

The two-story reinforced concrete building is generally square, with a projecting front bay and a flat concrete roof with parapet walls. The eastern facing building was constructed in two phases. The first section, which was built between 1917 and 1918, includes the projecting front entrance bay and one large room on each floor. It is approximately 18 feet wide and 27 feet long. The sides and rear section, which were added later, encased the back part of the first section and more than doubled the square footage of the mausoleum. The combined sections measure approximately 34 feet by 34 feet, plus the front entry bay, which is 18 feet wide and 11'6" deep. (Photo 1, Figure 5)

The concrete walls on all sides of the building are three feet thick at the first floor and two feet thick at the second story. Each side of the building varies in configuration. (Photos 2, 3, 8, 9)

¹ "Joseph M. Miller Trust", September 20, 1937. A copy has been made available through Carl Cranfill, executor of the trust and great-great grandson of Joseph M. Miller.

National Register of Historic Places
Continuation Sheet

Section number 7 Page 3

Miller, Joseph M., Mausoleum
Name of Property
Johnson County, Missouri
County and State
n/a
Name of multiple listing (if applicable)

The walls are rough, showing patterns formed by the boards used as forms during construction, and the east, north and south sides have been finished with gray stucco. All but two window openings have pointed, arch topped window openings with smooth shaped sills. All arched openings in the building have pointed arches, and many of those appear to have been formed from dimensioned lumber that was set at a 45 degree angle. (Photos 5, 6, 9, 17, 21) Most of the window openings are similar in size, with slight variations created by the individual forms used to shape each opening. Most of the window openings have deep-set wood frames and sashes, and doorways and window openings have decorative metal bars that are mounted near the outside edge of the openings. The bars appear to be early, and at least some of them may be original. Several window openings have been infilled with recessed concrete panels in more recent years. (Photos 3 and 14)

The flat roof is edged with parapet walls that are topped with projecting concrete coping. The parapets have projecting piers that continue the line of pillars and corner piers of the walls below. A domed cupola located near the center of the roof is constructed of concrete. The roof deck is a flat concrete slab; it is in fair to poor condition.

East Wall, Façade:

The front (east) wall is approximately 34 feet wide and has a central projecting bay that measures 18 feet across with return walls that are just over 11 feet deep. (Photo 2, Figure 5) The prominent front bay has four square two-story concrete pillars separated by pointed arches at the second floor roofline. At the first floor, the pillars rest on a smooth concrete porch floor that is two steps above grade. The pillars of the front bay measure 3 feet by 3 feet. They were expanded from their original size of 2 feet by 2 feet when concrete was added for reinforcement. The south two were enlarged ca. 1970 and the north pair were reinforced in the summer of 2017. All four pillars are now similar in material and dimensions and have a smooth finish.

The projecting bay is topped by a high stepped parapet wall that has a large centered nameplate. The nameplate consists of a flat recessed panel onto which are mounted enameled metal letters that spell the name "MILLER". The letters are early or original and in fair condition. Above that nameplate at the cornice line are evenly spaced lancet shaped indentations, plus four shallow brackets that support the concrete coping of the parapet wall. The same type of inset lancet shapes are used along the cornice lines of the entire east, north and south walls. (Photo 4)

The front pillars support a second-story porch or balcony, which has a concrete slab floor that is set back from the face of the pillars. (Photo 2) That floor replaced the original in the early 1970s; a thin metal railing is on the south side of the balcony and all other sides are open. A four-foot wide set of stairs on the north side of the façade leads up to the balcony and a single doorway

National Register of Historic Places
Continuation Sheet

Section number 7 Page 4

Miller, Joseph M., Mausoleum
Name of Property
Johnson County, Missouri
County and State
n/a
Name of multiple listing (if applicable)

that opens to the front room on the second floor. (Photos 1 and 2) The large stairway, which is early or original, fills the north one-third of the first-story porch.

At the balcony level of the front wall is a centered, flat topped window opening. That opening is secured by iron bars and there is some original framing and wood shutters at the inside of the opening. (Photo 15) That window, and a much smaller opening (approximately 12 inch by 8 inch wide) in the south wall of the east crypt room are the only two flat topped window openings in the building.

The front wall of the first floor, which is sheltered by the second-story balcony, is flat, with a central single doorway that leads to the front crypt room on the lower level. (Photo 2, behind cinderblocks at the first level) The doorway is low, measuring just 60 inches at the lintel and 34 inches wide. The original door and framing are missing, and the doorway is secured with early iron bars and a newer plywood panel. Just south of that doorway, at the southeast corner of the building, is a large granite headstone that was imbedded into the wall sometime between 1918 and 1934.² The headstone marked the original gravesite of John D. and Margaret A. Miller, parents of the builder; it was moved to this location at the time that their bodies were interred in the mausoleum. (Figure 8, see headstone next to Joseph Miller.)

There are four additional grave markers incorporated into the front wall of the building, just north of the projecting bay. Two of the markers are set back to back in the wall, so that one is visible inside the building and one is visible outside. (Photo 12. Interior photo of two of the markers. The marker on the right side has another grave stone behind it, which can be seen on the exterior of the concrete wall.) The exterior marker is set into a recess that has splayed sides. The remainder of the north portion of the front wall is flat, with a single tall arched window at each floor, and projecting corner piers.

The portion of the front wall located south of the front projecting bay includes a single, large arched window at the second floor, and a small recessed first floor porch that shelters a doorway to the back crypt room of the first floor. The porch is supported by short square posts similar to those of the front. The posts have recently been reinforced with additional concrete to address structural issues. They are similar in size, 3 feet by 3 feet, to the repaired front pillars and have a smooth finish.

North Side Wall:

The north side wall has a low water table that extends slightly above the ground level, pointed arch window openings at the first and second floors, and varying heights of the parapet walls

² "Family Tomb is Built by Missouri Farmer on His Land," *Weekly Kansas City Star*, ca. 1934, n.p., Johnson County Historical Society, Warrensburg, MO, Miller Mausoleum Vertical File.

National Register of Historic Places
Continuation Sheet

Section number 7 Page 5

Miller, Joseph M., Mausoleum
Name of Property
Johnson County, Missouri
County and State
n/a
Name of multiple listing (if applicable)

and piers. (Photo 3) The first floor wall is flat, with three window openings located in the mid-region of the wall; two are tall and narrow and the third is shorter and smaller. (Photo 5) The back part of the wall has several small rectangular openings covered with copper mesh that were installed for ventilation of the crypts inside.

Ledges and slightly recessed panels divide the first and second stories of the north wall. At the front section of this north wall, the ledge is about two inches deep, and at the back section it is six to eight inches deep. The second story has four window openings that are uniform in size and similarly shaped as those at the first floor. Two of the openings are in recessed panels in the mid-section of wall and the remaining two are in the back section. The entire wall is finished with gray stucco. The lowest level of the varying roof line has a poured concrete scupper for rain runoff from the flat roof. Lancet-shaped indentations are evenly spaced along the cornice line of the upper parapet wall. Many of the original wood molds used to create the indentations remain in the wall. (Photo 7)

West (Back) Wall:

This wall does not have a top finish. It is the only side without stucco, and the small gravel used in the concrete mix during construction is visible, along with marks from the boards that were used as concrete forms. The foundation is exposed approximately 12 to 16 inches along the back (west) wall, and there are no window and door openings on the first floor. (Photo 8) A small galvanized pipe with a 3 to 4 inch diameter opening is at the northwest corner of the back wall, just above the foundation. The pipe is reported to be part of a drainage system for the crypts located on the opposite side of the first story wall. The first and second story are divided by a recessed ledge that is approximately 6 to 8 inches deep. The upper level has four evenly spaced window openings. A second poured concrete scupper drains the roof at the upper north corner of the wall.

South Side Wall:

The first floor of the south side has the recessed porch that leads to the back crypt room, and the rest of the wall is flat, with no fenestration or ornament. (Photo 9, Figure 5) There is one small window opening that was completely filled with concrete after ca.1970; it was originally in the back crypt room of the first floor. (Figure 5)

The second floor has four arch topped window openings which are the same size as those on north wall. Two of the openings are separated by the piers which extend from the first floor porch to above the second-story roofline. The remaining two windows are in the back section. Lancet shaped indentations near the cornice line repeat on this wall, as seen on the front and north sides of the building. Many of the original wood molds also remain imbedded in those ornamental features. The entire wall is finished with gray stucco.

National Register of Historic Places
Continuation Sheet

Section number 7 Page 6

Miller, Joseph M., Mausoleum
Name of Property
Johnson County, Missouri
County and State
n/a
Name of multiple listing (if applicable)

Cupola:

A non-symmetrical, eight-sided domed cupola is centered on the roof. The top of the dome is flat and has a small observation platform. (Photo 10) It is accessible by a steep, narrow concrete staircase with fourteen stairs: each that are approximately 12 inches wide with a 12 inch rise. The staircase and platform have shaped concrete railings.

Pointed, arch topped window opening are centered in 6 of the 8 sides of the cupola. They are the same size and dimensions as those on the first and second levels of the building. Five of the windows have been closed off with concrete panels.³ The sixth window has a wood panel inside and iron bars near the surface of the wall. A narrow single doorway on the east side of the cupola has an arched top, and original wood framing, with a triangular transom and a two panel wood door. (Photo 1) The frame is in fair condition; the door is in poor condition. The roof and the inside of the cupola are accessed via a narrow concrete staircase from the second floor. (Photo 18, Figure 6) The cupola interior features a tall polygonal concrete ceiling, and parts of the parapet wall from the original section of the building are also visible.

Interior:

First Floor:

The first floor of the building contains two crypt rooms, each of which has an exterior doorway. They are linked by a narrow stairhall on the north side of the building. (Figure 5) The front crypt room is part of the first section; the stairhall and back crypt room are in the second section. On the east side of the mausoleum, the first floor doorway and five shallow steps lead down into the oldest crypt room, which was begun in 1917. The open part of the rectangular shaped room measures approximately 11-1/2 feet wide by 8-1/2 feet deep. The room has 14 concrete crypts that fill the west wall, and they are configured in an array of 3 high by 4 wide. (Photo 11) Each crypt measures approximately 2 ½ feet wide by 2 feet high and is fronted with a flat, white marble nameplate and matching marble trim; seven are inscribed with the names of the interred, and one additional plate reads "Six Children of JM and Laura Miller". The north, east and south walls have plates inscribed with the names of family members who are buried at cemeteries located in other towns and communities; no crypts are set into those three walls. The south wall has a small square-topped window about twelve inches high by eight inches wide. A doorway on the north wall of that room leads to the stair hall and the back part of the building.

The stair hall was added after 1919. A tall, narrow stairway along the north wall leads to the second floor. Two windows at the corner of the lower landing of the stairway help to illuminate the space. The short east wall of this corridor has four headstones imbedded into it. (Photo 12.

³ The windows were likely closed off in the 1970s, during the same time that two of the front piers were encased with additional layers of concrete.

National Register of Historic Places
Continuation Sheet

Section number 7 Page 7

Miller, Joseph M., Mausoleum
Name of Property
Johnson County, Missouri
County and State
n/a
Name of multiple listing (if applicable)

The stones belonged to children of the builder and his brother, and were set into the wall probably when the second section of the building was constructed, between ca. 1920 and ca.1927.)

At the west end of the passage is a short flight of steps that leads down to the back (west) crypt room. A door near the southeast corner of the back crypt room has four steps and a low doorway. The door is sheltered by the open porch on the south side of the building. Like the front, east door, the south side door is 60 inches high and 34 inches wide. Some original framing remains in this doorway, but the door is missing and the opening is secured with iron bars and plywood. The open space of the back (west) crypt room measures approximately 28 feet wide and 8-1/2 feet deep. (Photo 13) The wide room has 28 crypts, arranged 4 high by 7 wide. These crypts are similar in size to the ones in the east crypt room, and also have flat, white stone covers and trim; eight of the stones are inscribed. The name plates in the two crypt rooms are secured to the front of each vault by different systems. The east (front) room uses long copper bolts and decorative washers, and the west (back) room uses a series of interlocking stone panels and trim.

The east wall of the back crypt room has two large recessed areas that are separated by a pier. (Photo 13) The recessed area originally contained large murals on canvas with wood frames, but only a few remnants on one mural have survived. The niches are now empty, with an unfinished gray stucco finish. Most of the other walls and the ceilings on the first floor are finished with smooth white plaster. That finish is most intact on the ceilings and north interior walls. The floors are all of smooth gray concrete that appears to be original.

Second Floor:

The second floor has two open rooms, as well as wide north and south corridors that connect all rooms on that level of the building. (Figure 6) The front (east) room is a reception area that originally contained family photos, and the larger west room is referred to by family members as the museum. The reception room, which is located just above the front crypt room, measures 13 feet wide by 17 feet long. It has four doorways and a window. A single doorway near the northeast corner of the room leads to the second story balcony and the front staircase. (Photo 15) A central window with wide beveled sides is centered in that east wall. (Photo 15) Wide doorways that are four feet across are in the north and south walls, and also have beveled tops and sides. (Photo 15 and 16) The bevel terminates about two feet above the floor and the remainder of the opening is square. The side doorways may have originally been window openings that were cut at the lower wall to provide access into the second section of the building that was added between 1920 and 1937. A fourth doorway in the west wall also appears to have been cut into the original concrete wall for access to the back (west) upper room.

National Register of Historic Places
Continuation Sheet

Section number 7 Page 8

Miller, Joseph M., Mausoleum
Name of Property
Johnson County, Missouri
County and State
n/a
Name of multiple listing (if applicable)

The north corridor has a concrete banister that runs along the stairway opening to the first floor, and a passage way between the reception room and the museum. (Photo 14) The south hall has a narrow stairway along its north interior wall that wraps around a corner and continues up to the roof and cupola. The north corridor also connects the front and rear rooms on the second level. (Photos 17, 18)

The museum room measures 30 feet wide by 16-1/2 feet deep. There are four square posts and a central concrete beam that runs north south to support the roof. (Photos 19, 20) Two windows each in the north and south walls and four windows in the west (back) wall have original wood framing with pointed-arch transoms and two-light wood casement sashes. (Photo 21) Most of the sashes have early or original glazing and many also have wood shutters over the sashes. Those window openings are secured with iron bars. The walls of the museum room all have narrow wood ledger boards embedded in the approximate location a picture rail would have been located. They are believed to have been installed to support art and tapestries that were hung there when the room was new. The walls and ceilings on the second floor are unpainted concrete, and most show the pattern and indentations from the form boards used to make the building. The floors are all of smooth concrete.

Integrity

The Miller Mausoleum retains integrity through retention of original form and materials, and has seen limited changes since construction began one hundred years ago. The thick concrete walls punctuated with tall arched windows conveys the builder's original design. Repair of the weakened pillars at the east and south walls provided critical structural support, and the change does not overly detract from the design of the building. The new floor of the balcony, which was installed in the 1970s, is also comparable to the original. All but one of the window openings are intact and many of the windows retain early frames and sashes. The interior spaces retain integrity through an unaltered plan, and materials that have seen limited damage. The first floor has seen the most deterioration, due to some vandalism of the crypt covers, loss of original doors, and deterioration of the white plaster finish on the south walls. Those changes are minimal and the feeling of the mausoleum remains intact. The upper level is also highly intact, with original finishes and retention of wood frames and sashes in the back room.

National Register of Historic Places
Continuation Sheet

Section number 8 Page 9

Miller, Joseph M., Mausoleum
Name of Property
Johnson County, Missouri
County and State
n/a
Name of multiple listing (if applicable)

Summary

The Joseph M. Miller Mausoleum, located 8/10th of one mile north of the junction of Missouri HWY 131 and 2nd Street near the town of Holden, in Johnson County, Missouri is significant under National Register Criterion C in the area of ARCHITECTURE. It is locally significant as a vernacular family mausoleum made of reinforced concrete, using construction methods that were readily available in the first part of the twentieth century. The large mausoleum, which was built primarily by one man who was not a professional tradesman in the field of concrete construction, is distinctive in its design and clearly displays technological achievement in its construction. For these reasons it is eligible for listing in the National Register of Historic Places under Criteria Consideration D, a cemetery. The building was constructed by retired teacher and farmer Joseph Marion Miller, on land purchased specifically for construction of his home and a mausoleum. (The home is no longer standing.) The period of significance runs from 1917, when he began work on the building, and ends in 1937, when Miller determined that the building was complete, and he established a trust to ensure its future care and maintenance. A privy located near the mausoleum was built after the period of significance; it is the only other resource on the property and it is a non-contributing building. Miller constructed the mausoleum of poured reinforced concrete to serve as a final resting place for himself and members of his family. His preference for a mausoleum was in accordance with his religious beliefs, and to eliminate his fear of being buried in the wet ground. It was likely also influenced by the growing trend of mausoleum construction in the United States, which occurred while he was planning and building his own. The two-story building was erected in stages. The front part, which faces east, was built between 1917 and ca. 1918. Over the following years the building was expanded to the rear and sides, and a domed cupola was added to the roof. Miller was a religious scholar, and he added the domed cupola on the roof in an homage to domed tombs mentioned in the bible. The first burial at the building took place in 1925, and the last was in 1982. All told, twenty-three people were interred there. All human remains have subsequently been removed, and the building is currently vacant. The mausoleum appears today much as it did when Joseph Miller completed the construction project in the late 1930s. The majority of the historic architectural features are intact, including form and plan of the building, materials, and crypt construction. It clearly imparts a sense of time and place.

Elaboration

The Miller Family

Johnson County, Missouri is located less than fifty miles southeast of Kansas City, Missouri. The county was established in 1834, and by 1835 had designated Warrensburg the county seat.⁴ Today, the county remains predominately rural, with Warrensburg in the central-eastern

⁴ Ewing Cockrell, *History of Johnson County Missouri* (Topeka: Historical Publishing Co., 1918), 92, 95.

National Register of Historic Places
Continuation Sheet

Section number 8 Page 10

Miller, Joseph M., Mausoleum
Name of Property
Johnson County, Missouri
County and State
n/a
Name of multiple listing (if applicable)

region as the largest metropolitan area. The town of Knob Noster and the Whitman Air Force Base are close by.⁵

In 1858, the town of Holden was platted approximately fifteen miles southwest of Warrensburg. Holden is currently the largest town in the western half of the county with a population of around 2,300.⁶ Smaller farm towns can be found throughout the county along the roads and highways that dissect the county. Missouri Highway 131 is a two-lane road that runs north from Holden to Highway 50. Highway 50 connects with Warrensburg to the east, and Kansas City to the west. At the intersection of these two roads is the small farm town of Pittsville, Missouri. Beginning in 1867, farmer, teacher and businessman, Joseph Marion Miller and his family lived their lives first in Pittsville and then in Holden, and by 1937 had left a monumental marker of the Miller family heritage along Highway 131 that connects those two towns. (Figure 1)

Joseph M. Miller was the eldest son of John D. Miller and Margaret Ann (*nee* Scrutchfiled) Miller.⁷ John D. Miller was a farmer and merchant originally from Marion County, Missouri, who moved his family to Johnson County ca.1867 when Joseph was twelve years old.⁸ The Millers settled on a farm near Pittsville and raised Joseph and his five siblings.⁹ The family farmed the land until ca.1887 when John D. and Margaret Ann Miller retired nine miles south along Missouri Highway 131 to the town of Holden.¹⁰

Around 1875, about twelve years prior to his parents' retirement in Holden, Joseph left Pittsville to attend the Warrensburg State Normal School for teacher training, and then moved to Iowa to teach for two years.¹¹ By the spring of 1879 he had returned to the Pittsville area and married Laura Alice Lundy.¹² Following his marriage, Joseph returned to farming and continued to teach for 12 more years at the Washington No. 7 School.¹³ In 1880, Joseph and Laura had their first child, Fred. (Figure 7)

In addition to being a teacher, Joseph was a successful farmer and businessman. According to Miller family history, an 1898 business directory listed him as a merchant, farmer, and breeder of short-horn cattle.¹⁴ He and Laura owned over 300 acres known as the "Shady Row Stock

⁵ "General Highway Map Johnson County," MoDot Office of Transportation and Planning, 2005, accessed July 6, 2017.

⁶ "Population, Holden MO," Population.us, accessed July 26, 2017, <http://population.us/mo/holden/>.

⁷ Cockrell, *History of Johnson County Missouri*, 643; Carl Cranfill, *A Heritage to Cherish*, edited by Lisa Ailshie, (Self-published, 2016), 42.

⁸ Cranfill, *A Heritage to Cherish*, 41-43.

⁹ Cranfill, *A Heritage to Cherish*, 42.

¹⁰ Cockrell, *History of Johnson County Missouri*, 643; Carl Cranfill, *A Heritage to Cherish*, 43.

¹¹ Cranfill, *A Heritage to Cherish*, 44.

¹² Cranfill, *A Heritage to Cherish*, 44-45.

¹³ Cranfill, *A Heritage to Cherish*, 44.

¹⁴ Cranfill, *A Heritage to Cherish*, 45.

National Register of Historic Places
Continuation Sheet

Section number 8 Page 11

Miller, Joseph M., Mausoleum
Name of Property
Johnson County, Missouri
County and State
n/a
Name of multiple listing (if applicable)

Farm” in Pittsville, and a lumber business in Oklahoma.¹⁵ Joseph Miller was also a civic leader who served as President of the Farmers Alliance of Missouri in 1892, and a member of the Lodge of Independent Order of Odd Fellows, and the Ancient Free and Accepted Masons.¹⁶ He was involved with business transactions and civic duties all of his adult life. The 1918 *History of Johnson County Missouri* described Joseph M. Miller as “a prominent citizen of Madison township,...one of Johnson County’s most valued and public-spirited men.”¹⁷

Joseph and Laura had a busy and prosperous life in Pittsville. After Fred was born in 1880, the couple had eight more children. Six of those babies died within their first year. The three surviving children were Fred, Elsie and Edwin.¹⁸ Like their parents Joseph and Laura, these three children remained in southwest Missouri throughout their long lives. Fred and Elsie stayed in Pittsville, and Edwin moved to the Kansas City region.¹⁹ By 1915, at the age of sixty, Joseph and Laura were ready for retirement, and like their parents, John D. and Margaret Ann Miller, the couple retired to the Holden area.

The Project

Joseph had planned a project for his retirement years, which was to construct a mausoleum as a final resting place for himself and his family. His daughter, Elsie (*nee* Miller) Henderson, reported during a 1975 interview with Bob Harris of the *Daily Star-Journal* that her father had begun planning the mausoleum decades before his retirement.²⁰ Information from local newspapers and the *History of Johnson County, Missouri* show that once he had purchased a fifteen acre site north of Holden, that plan was promptly put into action. Today, facing east, along Highway 131, is a large, two-story reinforced concrete mausoleum built by Joseph M. Miller which has become part of his legacy in Johnson County. (Photo 1)

The first building project Miller undertook on his new property was the construction of a new brick and frame farmhouse for Laura, Joseph, and Edwin, the youngest son who was still in high school in 1915.²¹ The September 16, 1915 edition of the *Holden Enterprise* noted that “J.M. Miller, of Pittsville, is having a residence erected in Holden.” In 1918, the house was described

¹⁵ Cranfill, *A Heritage to Cherish*, 45.

¹⁶ Cranfill, *A Heritage to Cherish*, 45.

¹⁷ Cockrell, *History of Johnson County Missouri*, 643.

¹⁸ Cranfill, *A Heritage to Cherish*, 48.

¹⁹ Cranfill, *A Heritage to Cherish*, 47-48.

²⁰ Bob Harris, “Mysterious Miller Mausoleum,” *Daily Star-Journal* (Warrensburg, MO), Jan. 22, 1975, n.p. Johnson County Historical Society, Warrensburg, MO, Miller Mausoleum Vertical File.

²¹ Cockrell, *History of Johnson County Missouri*, 644; “Family Tomb is Built by Missouri Farmer on His Land,” n.p.

National Register of Historic Places
Continuation Sheet

Section number 8 Page 12

Miller, Joseph M., Mausoleum
Name of Property
Johnson County, Missouri
County and State
n/a
Name of multiple listing (if applicable)

as “a handsome, modern county home located a short distance from this city [Holden].”²² (That building was destroyed by fire in December of 2004.²³)

The house was quickly erected, and Miller moved to construction of the mausoleum. The July 13, 1917 issue of the *Warrensburg Standard-Herald* printed “Joseph M. Miller is erecting a burial vault at his premise north of town,” and by the printing of the 1918 *History of Johnson County Missouri*, he had completed the first section of the building. The county history proclaimed that Miller “has erected a beautiful mausoleum to be occupied in the years to come by his immediate family and their descendants. This tomb is well constructed of cement and stone, perfectly reinforced with three or four tons of steel, and it is surrounded by a park.”²⁴

Miller continued to work on the building in stages following the completion of that first section. By the late 1920s he had expanded it to twice its original size, and then slowed his pace in the 1930s and worked on smaller details until 1937, when a trust was established for the perpetual care of the mausoleum. According to Miller family history, the second section was finished by 1927 and the upper story had been opened as a free museum.²⁵ Miller reported in 1934 that “the main structure is done but the doors are not in place or the finishing touches completed.”²⁶ By 1937, when the “Joseph M. Miller Trust” was signed by Alice and Joseph Miller, the mausoleum was complete and he had spent most of his life-savings on its construction.²⁷

While Miller was deeply invested in development of the family mausoleum, he also gave thought to the perpetual care of other members of his community. In 1975, during her interview with the *Daily Star-Journal*, Elsie stated that her father had hoped others would also choose to build mausoleums on his land, and that he had set aside ten acres “out there for mausoleums. But Holden is too small a place for people to be able to afford those things. Mausoleums are too expensive.”²⁸

Although the cemetery was never developed, the trust clarifies his intentions for the Miller mausoleum and a cemetery to occupy the 15.69 acres purchased in 1915, but on two separate tracts within that area. The first tract was described as “a tract of land 250 feet east and west by 250 feet north and south on which is situated the Joseph M. Miller Mausoleum...” and the second tract was, “to be known as the Joseph M. Miller Cemetery and held by the said trustees

²² Cockrell, *History of Johnson County Missouri*, 644.

²³ Christi Stowe, “Tragedy mars Christmas holiday for Holden family when home burns,” Holden newspaper (Holden, MO), December 2004, n.p. Clipping provided by Cochran family of Holden, MO.

²⁴ Cockrell, *History of Johnson County Missouri*, 644.

²⁵ Cranfill, *A Heritage to Cherish*, 49.

²⁶ “Family Tomb is Built by Missouri Farmer on His Land.” n.p.

²⁷ Cranfill, *A Heritage to Cherish*, 49; “Joseph M. Miller Trust”, September 20, 1937.

²⁸ Harris, “Mysterious Miller Mausoleum,” n.p.

National Register of Historic Places
Continuation Sheet

Section number 8 Page 13

Miller, Joseph M., Mausoleum
Name of Property
Johnson County, Missouri
County and State
n/a
Name of multiple listing (if applicable)

in perpetuity: it being my intention and purpose that said two above described tracts shall be held by said trustees....”²⁹

Where the boundary line for the Mausoleum area stops and the cemetery starts is not clearly stated in the trust. The boundaries for the nominated property were determined by two sources: the instructions from the trust for a 250 square foot parcel, which set the precedent for the size of the nominated property, and the estimated location of a low stone wall that was located just south of the mausoleum in the twentieth century. The wall, which can be seen in a ca. 1970 photo but no longer exists, was likely a boundary for the mausoleum tract. (Figures 3 and 4)

Miller’s Motivation and the Mausoleum Movement in the United States

The unusual building piqued the interest of local community members, and in 1934 reporters from the *Weekly Kansas City Star* traveled to Holden to interview Miller about his mausoleum and find out what had motivated him to build it.³⁰ Joseph Miller was seventy-nine years old at the time of the interview, and he told the reporters that memories from his childhood and Biblical studies guided him in his venture. He had become concerned as a boy about being set in the wet ground, and decided at that time he would be buried above ground. He said during his interview, “I dreaded the thought of lying in the water that settles into practically all graves.”³¹ He also believed that his mausoleum was representative of the tombs that Abraham and other Biblical figures had been buried in; and noted that other cultures throughout history had also buried their dead in tombs.³² The article ended by listing Miller as a Methodist and former lecturer on Biblical subjects, and stated that “He has many ideas independent of the beliefs of his church.”³³ (Figure 7)

Joseph Miller had been raised in the Pittsville Cumberland Presbyterian church, which his parents attended when he was young.³⁴ As an adult, he and Laura were active members of the Blackwater Methodist church in Pittsville.³⁵ Miller family history described him as a religious scholar, who was “very proficient in religious studies as an early age,” and he carried his devotion to his faith throughout his life, eventually becoming an ordained minister in 1915.³⁶ That position gave him opportunity to write about and give lectures on a wide variety of topics including Biblical, history and theology.³⁷

²⁹ “Joseph M. Miller Trust”, September 20, 1937, 1.

³⁰ “Family Tomb is Built by Missouri Farmer on His Land,” n.p.

³¹ “Family Tomb is Built by Missouri Farmer on His Land,” 1934, n.p.

³² “Family Tomb is Built by Missouri Farmer on His Land,” 1934, n.p.

³³ “Family Tomb is Built by Missouri Farmer on His Land,” 1934, n.p.

³⁴ Cranfill, *A Heritage to Cherish*, 42.

³⁵ Cranfill, *A Heritage to Cherish*, 46.

³⁶ Cranfill, *A Heritage to Cherish*, 46.

³⁷ Cranfill, *A Heritage to Cherish*, 46.

National Register of Historic Places
Continuation Sheet

Section number 8 Page 14

Miller, Joseph M., Mausoleum
Name of Property
Johnson County, Missouri
County and State
n/a
Name of multiple listing (if applicable)

Articles written about Miller's mausoleum since its completion often mention that travelers along Highway 131 may have been curious and surprised by the unusual building.³⁸ Over the years, it became significant to the community as a family mausoleum, which was as distinctive in its design as the man who built it. Albeit large and unusual for Johnson County at the time that Miller was planning and building his mausoleum, it reflects a national trend that was developing in the construction and use of large community mausoleums in multiple states across the county, including Missouri. This trend may have influenced some of Miller's choices in construction materials and design of his vernacular mausoleum.

In the 1800s, Victorian funerary practices resulted in the development of cemeteries that were viewed as places of sanctuary for the dead, and the living who bereaved their loss.³⁹ Ideas that portrayed the Victorian home as a place of private refuge transferred to cemeteries. Researcher and author, Katherine Corbett wrote in "Bellfontaine Cemetery, St. Louis City of the Dead" that "in the city of the living each family aspired to its privately owned, personally decorated sanctuary; these ideas would be mirrored in the cemetery, the city of the dead."⁴⁰ Beginning in 1831, with Mount Auburn in Boston, Massachusetts, cities had begun to develop pastoral rural cemeteries on the outskirts of the city limits for sanitary purposes, and they quickly evolved into settings which joined art and nature for aesthetic pleasure.⁴¹

Cemetery tombstones, grave markers and monuments became highly styled in the mid-1800s, as did above-ground tombs and family mausoleums that became popular in the late 1800s. Ann Morris conducted an extensive survey of cemeteries in St. Louis County, Missouri in 2000, where she examined the numbers and types of burial locations in that area. In a review of the types of monuments and art placed in the cemeteries she commented that "the ultimate expression of Victorian funerary art was the family mausoleum. From 1880 to the 1920s successful capitalists spent their new wealth on family mausoleums..."⁴²

At the turn of the twentieth century, the idea of a mausoleum built only for one person or a single family expanded into the construction of large community mausoleums that could keep many bodies. They featured large rooms such as chapels or wide reception hallways that were light-filled, often with the concrete vaults along the sides of those central gathering spaces.⁴³

³⁸ "Family Tomb is Built by Missouri Farmer on His Land," 1934, n.p.; Ruth Dudley, "Holden Mausoleum Perpetuates Founder's Memory - J.M. Miller," *Daily Star-Journal* (Warrensburg, MO), Dec. 21, 1967, n.p.; Stephanie Edwards, "Miller Mausoleum Still a Fascination." *Holden Image* (Holden, MO), June 4, 2012.

³⁹ Katherine T. Corbett, "Bellefontaine Cemetery, St. Louis City of the Dead." *Gateway Heritage* 2(1991): 58-59.

⁴⁰ Corbett, "Bellefontaine Cemetery, St. Louis City of the Dead," 59.

⁴¹ Corbett, "Bellefontaine Cemetery, St. Louis City of the Dead," 60.

⁴² Ann Morris, "Sacred Green Space, A Survey of Cemeteries in St. Louis County," Missouri State Historic Preservation Office, 2000, accessed July 2, 2017, <http://dnr.mo.gov/shpo/survey/SLAS032-R.pdf>.

⁴³ David G. Stuart, "Old Mission Mausoleum," National Register of Historic Places Nomination, May 21, 2009, (Washington D.C.: National Park Service, Department of the Interior), plans.

National Register of Historic Places
Continuation Sheet

Section number 8 Page 15

Miller, Joseph M., Mausoleum
Name of Property
Johnson County, Missouri
County and State
n/a
Name of multiple listing (if applicable)

These large buildings were intended to alleviate overcrowding in cemeteries, offer a forward thinking or progressive response to the inevitable and eternal human condition of death, and comfort those who feared burial in the ground. Publications and advertisements proclaiming the advantages of mausoleums began to appear in trade magazines and newspapers in the early 1900s.⁴⁴

Joseph Miller was not alone in thinking that a mausoleum was a better resting place than a grave beneath the soil. In 1914, an editorial titled 'Post Cineres Gloriam Venit' praised the history of mausoleums and proclaimed the advantages of their use. Author, W. C. Jenkins, wrote "A wave of sentiment in favor of mausoleum entombment has swept over parts of several states during the past five years, and more persons are daily engaged in building private and community homes for the dead."⁴⁵

Jenkin's lengthy article examined the history of tombs and mausoleums, particularly those used by ancient and religious figures. Illustrations in his article showed pictures of the tomb of the Virgin Mary and the dome topped tomb of Rachel in Palestine.⁴⁶ Whether through this article or other research, Miller knew about Mary's tomb, and that domes were commonly used in early Judeo-Christian tombs. During his 1934 interview with the *Weekly Kansas City Star* he showed his guests a large painting of the tomb of the Virgin Mary that was hung in his mausoleum, and he explained that a flattened dome constructed on the top of the building was "his interpretation of the domes on the temples of the orient."⁴⁷

Safety and eternal rest were also promised in mausoleums through claims such as "the foremost mausoleum builders of this country assert that the methods employed provide for concrete interior work as lasting as the pyramids."⁴⁸ In 1917, an advertisement printed in the *Daily Republican*, which circulated through the Cape Girardeau area in southeast Missouri, advertised vaults available in the "Temple of Rest" mausoleum being built in the New Lorimier Cemetery. The Mo.-Ill. Mausoleum Company, who sponsored the ad, sought to persuade people that interment in the mausoleum would comfort the living by knowing that their loved ones "lie secure and calm behind the sealed slab of a marble wall..."⁴⁹

⁴⁴ "The Temple of Rest" Mausoleum, Blog, advertisement reprinted from the *Daily Republican*, Dec. 1 1917, *Southeast Missourian*, (Cape Girardeau, MO), 3, accessed July 5, 2017, <http://www.semissourian.com/blogs/flynch/entry/47594>; M.C. Jenkins, "Post Cineres Gloriam Ventit," *National Magazine* 40 (Jan. 1914): 641-651. Google Books, accessed July 3, 2017, <https://play.google.com/books/reader?id=Fs1OAAQAAAJ&printsec=frontcover&output=reader&hl=en&pg=GBS.PA636>.

⁴⁵ Jenkins, "Post Cineres Gloriam Ventit," 642.

⁴⁶ Jenkins, "Post Cineres Gloriam Ventit," 641 and 642.

⁴⁷ "Family Tomb is Built by Missouri Farmer on His Land," 1934, n.p.

⁴⁸ Jenkins, "Post Cineres Gloriam Ventit," 646.

⁴⁹ "The Temple of Rest" Mausoleum, Blog, 3.

National Register of Historic Places
Continuation Sheet

Section number 8 Page 16

Miller, Joseph M., Mausoleum
Name of Property
Johnson County, Missouri
County and State
n/a
Name of multiple listing (if applicable)

Like other people who purchased vaults in community crypts for the reasons advertised by mausoleum companies, Miller wanted to provide a safe place for himself and family. He also was not alone in his fear of eternally lying in the wet of the ground. Mausoleum companies worked to evoke emotional responses from their readers by publishing statements such as “Your mortal remains will be placed in a watery grave to be devoured by the vermin of earth.”⁵⁰ Jenkins stated that ground burials were a brutal custom that dammed the dead “to a bleak and often neglected cemetery, with the cold, wet ground for a bed,” until the final awakening.⁵¹ Choosing to build a mausoleum out of reinforced concrete, a versatile construction material that had gained popularity around the turn of the twentieth century for being a strong and enduring product, provided a solution to those problems.

Construction of the Joseph M. Miller Mausoleum

Joseph M. Miller’s building is significant as a vernacular family mausoleum, and he selected reinforced concrete as a building material that would protect himself and his family in their final resting place for a long time. In 1917, when he began construction of his private mausoleum in Holden, Missouri, concrete construction in the United States had already been experimented with as an important and versatile building material for one century.⁵² One of the most well-known early commercial projects was construction of the 363 mile Erie Canal from 1817 to 1825 in the upper northeast region of the United States.⁵³ This early project utilized hydraulic cement, and in the century to follow, different methods and materials that would expand the use and applications of this moldable, durable, water resistant material were developed by professional builders in commercial construction and by individuals in smaller scale residential and farm projects.

By the mid-1800s, reinforced concrete emerged as another significant development in concrete construction in the United States. In 1854, author Orson S. Fowler wrote a book titled *A Home for All*, in which he chronicled the construction of his octagonal concrete house. His book praised the use of calcified lime, sand and rock in construction of what he termed the “gravel wall”. The book made available to the general public detailed instructions on acquisition of lime and stone, along with methods for building a concrete reinforced wall and subsequent house. The book reviewed for the unskilled laborer the experimental nature of constructing the house, where he learned how to correct mistakes made, for example, in certain mixes and setting

⁵⁰ “The Temple of Rest” Mausoleum, Blog, 2.

⁵¹ Jenkins, “Post Cineres Gloriam Ventit,” 638.

⁵² “Joseph M. Miller is erecting a burial vault at his premises north of town,” *Warrensberg Standard-Herald* (Warrensburg, MO) July 13, 1917, Trails Regional Library, Warrensburg, MO.

⁵³ “A National Treasure,” Erie Canalway, National Heritage Corridor, accessed July 18, 2017, <https://eriecanalway.org/learn/history-culture>.

National Register of Historic Places
Continuation Sheet

Section number 8 Page 17

Miller, Joseph M., Mausoleum
Name of Property
Johnson County, Missouri
County and State
n/a
Name of multiple listing (if applicable)

times.⁵⁴ According to Amy E. Slaton in *Twentieth-Century Building Materials*, by 1860 he advanced his method enough to secure a patent for a reinforced concrete wall.⁵⁵

Slaton wrote that acceptance of concrete as a building material was slow, but by 1877, American engineer Thaddeus Hyatt published *An Account of Some Experiments with Portland Cement Concrete, Combined with Iron, as a Building Material* which reviewed his many experiments in the use of iron reinforcing rods in conjunction with concrete. By the 1890s, the precedent of using iron reinforced concrete in commercial construction to build larger and taller buildings and structures in the United States was led by engineer and architect Ernest Ransome.⁵⁶ His pioneering work was followed by additional techniques that emerged around 1900, all of which aided the exponential growth of reinforced concrete construction in the United States at the turn of the twentieth century.⁵⁷

The growing popularity of reinforced concrete construction spawned the publication of numerous pattern books and builder's guides that offered advice on how to build with concrete. In 1911, for example, the Norman W. Henley Publishing Company in New York issued the *Catalogue of Good, Practical Books*. Two of the fifteen publications listed under the title of "Concrete" are *Popular Handbook for Cement and Concrete Users*, by Myron H. Lewis and *Concrete Monuments, Mausoleums and Burial Vaults* by A. A. Houghton.⁵⁸

Popular Handbook for Cement and Concrete Users is a 430 page book which explains in great detail how to build with reinforced concrete. A few examples of subjects covered in the book are "Concrete Foundation Work," "How to Design Reinforced Concrete Beams, Slabs and Columns," "Systems of Reinforcement," and the "Cost of Concrete Work," which is a chapter filled with charts and tables to help the builder accurately calculate materials and price. *Concrete Monuments, Mausoleums and Burial Vaults* is a sixty five page guide to the design and construction of such items.

⁵⁴ O.S. Fowler, *A Home for All or The Gravel Wall and Octagon Mode of Building* (New York: Fowlers & Wells, 1854), 26-27, Google Books, Accessed July 7, 2017, https://books.google.com/books/about/A_Home_for_All.html?id=jF9JAQAAIAAJ.

⁵⁵ Amy E. Slaton, et. al., "Reinforced Concrete," *Twentieth-Century Building Materials, History and Conservation*, edited by Thomas C. Jester (New York: McGraw-Hill, 1995), 94.

⁵⁶ Slaton, et. al., 94-95.

⁵⁷ Slaton, et. al., 94-95.

⁵⁸ Myron H Lewis and Albert H. Chandler, *Popular Hand Book For Cement and Concrete Users* (New York: Norman W. Henley Publishing Company, 1911), Google Books, accessed July 7, 2017, <https://books.google.com/books?id=TYM0AAAAMAAJ&printsec=frontcover&dq=popular+hand+book+for+cement+and+concrete+users&hl=en&sa=X&ved=>; A.A. Houghton, *Concrete Monuments, Mausoleums and Burial Vaults* (New York: Norman W. Henley Publishing Co., 1911), Google Books, accessed July 3, 2017, <https://books.google.com/books?id=2aJXAAAAYAAJ&pg=RA1-PA13&dq=concrete+monuments+mausoleums+and+burial+vaults&hl=en&sa=X&ved=>.

National Register of Historic Places
Continuation Sheet

Section number 8 Page 18

Miller, Joseph M., Mausoleum
Name of Property
Johnson County, Missouri
County and State
n/a
Name of multiple listing (if applicable)

It is likely that Miller consulted comparable pattern books as he was planning and constructing the large family mausoleum on his property. As a teacher, farmer and businessman, Joseph M. Miller would have had the ability to research materials, methods and cost for construction of his mausoleum. According to Carl Cranfill, Miller's great-great grandson, Miller built most of the mausoleum by himself, so he most likely had at least a basic understanding of tool use and building skills.⁵⁹ The building is a technological achievement in its construction for one man, and how he achieved that feat may be explained in those pattern books, as many of the techniques are similar to what appears in the building.

Material such as cement, rock, sand and wood for Miller's project may have been shipped in by train and sourced from suppliers for the Johnson County roads industry. Multiple railroads passed through Holden beginning in 1865, bringing supplies from across the mid and central regions of Missouri and Kansas. The first was the Pacific Railroad, which ran from St. Louis to Kansas City, followed by the St. Louis and Santa Fe, the St. Louis and San Francisco and the Missouri, Kansas and Texas (MKT).⁶⁰ Carl Cranfill reports that his great-great grandfather purchased the land for the mausoleum close to Holden specifically because the town had railroad access less than one mile away from the construction site.⁶¹ (Figure 1) Pittsville, which is nine miles north of Holden along Missouri Highway 131, did not have railroad access in the 1910s, and additional mileage to the train depots would have made transportation of raw materials to the work site difficult.

Joseph Miller may have also been able to source some of the materials from suppliers or construction companies who were building roads in Johnson County at the same time that he was working on the mausoleum. He was a proponent of building good roads throughout Johnson County, and was associated with the "Good Roads" committee according to an editorial he submitted to the *Holden Enterprise* in 1914.⁶² That committee was involved with submitting legislation for road development to the Missouri Legislature. In 1917, the county invested \$130,734.00 in road and bridge construction and maintenance.⁶³ Most of the roads they were laying and maintaining were gravel covered, but they had invested in constructing almost 1000 concrete culverts throughout the county between 1910 and 1918.⁶⁴ Miller's involvement with the good roads committee may have given him a connection to this industry and local sources of building materials such as rock and sand.

The Joseph M. Miller Mausoleum was constructed in phases, and the two-story concrete walls reveal differences in wall design and construction used between 1917 and 1937. Consistently,

⁵⁹ Carl Cranfill, interview with Deb Sheals, June 22, 2017.

⁶⁰ Cockrell, *History of Johnson County Missouri*, 103-105.

⁶¹ Carl Cranfill, phone interview with Andrea Herries, July 11, 2017.

⁶² "Good Roads." *Holden Enterprise*, Jan. 31, 1914, n.p.

⁶³ Cockrell, *History of Johnson County Missouri*, 84.

⁶⁴ Cockrell, *History of Johnson County Missouri*, 82-83.

National Register of Historic Places
Continuation Sheet

Section number 8 Page 19

Miller, Joseph M., Mausoleum
Name of Property
Johnson County, Missouri
County and State
n/a
Name of multiple listing (if applicable)

all of the concrete walls show indentations that remain from eight to twelve inch wide horizontal boards. The primary difference in wall design is seen at the front (east) half of the building, which has two-story square columns with recessed wall sections between them, and the back (west) half of the mausoleum which has flat walls and no columns. (Photos 2, 3, 6, 9)

For the front part of the building, Miller may have followed instructions and diagrams for the construction of square column forms and trough walls. As explained in *Popular Handbook for Cement and Concrete Users*, columns provide support for a vertical trough created by wall forms secured between them.⁶⁵ When completed, the concrete walls are slightly recessed from the columns. (Photo 9) The book gives three systems of forms for trough walls that use horizontal boards, two of which are easily movable, allowing the builder to reuse them instead of building new forms each time a new section of the wall is set. (Figure 9, Movable Wall Forms) For the back section, Miller may have used forms that were built up as a single unit, but raised up only as high as needed for each separate pouring. According to *Popular Handbook for Cement and Concrete Users*, this system is made of studding and matched boards, which allows for easier pouring results and a flush wall surface.⁶⁶ (Figure 9, Forms Made of Studding and Matched Boards, and Photos 6, 9)

The interior walls, beams and ceilings in the mausoleum show that Miller followed the advice of builders' guides by including metal reinforcement in the poured concrete. Spalling of small sections of concrete on the interior walls and ceilings have revealed rods, beams, and what appear to be metal parts from old farm implements and cars. (Photo 20) Metal pieces with long levers and handles, and strips with metal rings and nuts and bolts attached are visible in the ceilings of the upper floor.⁶⁷ Miller may have learned the mechanics of properly imbedding metal reinforcement within the concrete from readily available manuals. *Popular Handbook for Cement and Concrete Users* dedicated five chapters to the theory, design and construction of reinforced concrete components such as slabs, columns, floors, loads, walls and roofs. Diagrams in the book show proper, and often improper, ways to use reinforcements along with mathematical equations for figuring necessary spans and loads. (Figure 10)

Ideas and methods for application of the stucco wall finish and decorative architectural elements on the mausoleum may have also come from handbooks. The east, north and south exterior sides of the mausoleum all have an early or original stucco top coat. The *Popular Handbook for Cement and Concrete Users* recommends that "Houses having solid walls of monolithic concrete are best treated by making the surfaces of the walls unbroken without attempting to

⁶⁵ Myron H. Lewis, and Albert H. Chandler, *Popular Hand Book For Cement and Concrete Users*, 69-71.

⁶⁶ Lewis and Chandler, *Popular Hand Book For Cement and Concrete Users*, 68-69.

⁶⁷ The cupola added to the roof also has visible metal implements on the ceiling that are shaped differently than commonly used iron rods and rails in metal reinforced concrete.

National Register of Historic Places
Continuation Sheet

Section number 8 Page 20

Miller, Joseph M., Mausoleum
Name of Property
Johnson County, Missouri
County and State
n/a
Name of multiple listing (if applicable)

imitate masonry or joints in stone.”⁶⁸ Five types of finishes are recommend, one being “surfacing with mortar or stucco.”⁶⁹

Miller designed his two-story mausoleum with simple Gothic Revival styling, which was popular in funerary architecture in the nineteenth century. According to Douglas Keister in *Stories in Stone*, Gothic Revival styling is one of six broad groups of American cemetery architecture, and he writes in this 2004 publication that “Perhaps no style of architecture is so closely associated with cemeteries as Gothic.”⁷⁰ Miller may have seen many examples of Gothic architecture used in other cemeteries and mausoleums during the late 1800s and early 1900s and decided to model his mausoleum in the same fashion. As a biblical scholar and Methodist minister, he may have also chosen to use this style for its close ties to Christianity. Keister states that Gothic Revival is “in fact, the first purely Christian architecture.”⁷¹

Miller’s interpretation of Gothic Revival design is evident through verticality in the two-story pillars on the front of the building and the pointed arches in the upper wall of that façade, along with pointed-arch window openings on the first and second floors, and the lancet shaped indentations at the cornice line. (Photo 2, 4, 5, 9) The window openings once contained art glass, another decorative architectural element found in Gothic Revival design. Joseph Miller probably constructed the wood window frames and sashes, and may have purchased the art glass that was installed in them. Many of those original frames remain in the window openings on the second floor back room.⁷² The windows have triangular transoms, four inch painted trim boards and stools, and functioning sashes with clear glazing. (Photo 21)

The ornamental lancet shaped indentations on the exterior walls were formed with wood molds set into the wall forms prior to pouring of the concrete. Many of those molds were not removed at the time of construction and remain in niches along the south and north walls. (Photo 7) Methods for using that type of inverse mold are explained in the handbooks previously mentioned. One of these books, *Concrete Monuments, Mausoleums and Burial* gives directions and diagrams that show how to shape recessed letters, decorative borders and emblems in wood that can then be applied in relief to concrete monuments.⁷³ (Figure 12)

⁶⁸ Lewis and Chandler, *Popular Hand Book For Cement and Concrete Users*, 84.

⁶⁹ Lewis and Chandler, *Popular Hand Book For Cement and Concrete Users*, 84.

⁷⁰ Douglas Keister, *Stories in Stone, A Field Guide to Cemetery Symbolism and Iconography* (Salt Lake City: Gibbs, Smith, 2004), 13 and 21.

⁷¹ Keister, 20.

⁷² Multiple frames are stacked on the second-story floor. These frames may fit the openings that are currently filled with concrete panels for security purposes.

⁷³ A.A. Houghton, *Concrete Monuments, Mausoleums and Burial Vaults*, (New York: Norman W. Henley Publishing Co., 1911), 38-46, Google Books, accessed July 3, 2017, <https://books.google.com/books?id=2aJXAAAAYAAJ&pg=RA1-PA13&dq=concrete+monuments+mausoleums+and+burial+vaults&hl=en&sa=X&ved=>

National Register of Historic Places
Continuation Sheet

Section number 8 Page 21

Miller, Joseph M., Mausoleum
Name of Property
Johnson County, Missouri
County and State
n/a
Name of multiple listing (if applicable)

The decorative detail in the building was purposeful, and the time and attention dedicated to items such as the windows and lancet indentations along the cornice line show Miller's intention to have the mausoleum be a place of beauty. His trust also made his intentions clear by instructing that the mausoleum was to be kept in a high state of repair and the surroundings "a place of continueing [sic] beauty."⁷⁴

Construction of the interior of the mausoleum was given equal attention by Miller, expressing his values and theological ideology, as well as his desire to memorialize family and friends. The first floor, where the two crypt rooms are located, was designed for perpetual care of the dead, and the upper floor, where art and family artifacts were displayed, was intended to be visited by surviving members of the family and community.⁷⁵ The mausoleum is light filled, particularly on the second floor. The white stone nameplates and trim that cover the forty vaults and the walls that were finished with bright white plaster on the first floor also help to lighten the rooms.

On the second floor, large oil paintings with religious themes were hung on the walls of the museum room, which is a large open room at the back of the building.⁷⁶ (Figure 6) The plan of the room is unchanged since construction, but only one frame and remnants of that painting remain. According to Miller family history, "muskets, derringers, swords, Indian relics, and a beautiful hand-woven tapestry" were also displayed in this back room.⁷⁷ (Figure 6) The reception room at the front of the second floor was used for the display of family photos.⁷⁸ This room may have also had a small wood burning stove, as evidenced by a small circular hole and pipe that remain in the west wall of this room. Heating the upper floor of the mausoleum would have made it accessible for visitors year round.

By the time that the Joseph M. Miller Mausoleum was featured in the *Weekly Kansas City Star* in 1934, most of the construction of the building was complete.⁷⁹ The first and second floors, and the domed cupola were done, and only installation of doors and finishing touches remained.⁸⁰ The non-symmetrical eight sided cupola has window openings on six of the sides that were fitted with wood sashes and art glass by Miller. The windows were removed many years ago, but the vertical wood plank door which provides access to the rooftop is intact. Miller built the cupola with a flattened top that he used as an observation platform to be able to view the surrounding countryside.

⁷⁴ "Joseph M. Miller Trust", September 20, 1937.

⁷⁵ Cranfill, *A Heritage to Cherish*, 49.

⁷⁶ "Family Tomb is Built by Missouri Farmer on His Land," *Weekly Kansas City Star*, ca. 1934, n.p., Johnson County Historical Society, Warrensburg, MO, Miller Mausoleum Vertical File.

⁷⁷ Cranfill, *A Heritage to Cherish*, 49.

⁷⁸ "Family Tomb is Built by Missouri Farmer on His Land," n.p.

⁷⁹ "Family Tomb is Built by Missouri Farmer on His Land," n.p.

⁸⁰ "Family Tomb is Built by Missouri Farmer on His Land," n.p.

National Register of Historic Places
Continuation Sheet

Section number 8 Page 22

Miller, Joseph M., Mausoleum
Name of Property
Johnson County, Missouri
County and State
n/a
Name of multiple listing (if applicable)

While Miller was able to construct a building of distinct design that honored the memory of family and friends, he also had to give attention to the engineering of the crypts, which was the main purpose of the building. He may have been aided in this work by builders' guides as well as patents for mausoleums. These sources provided instruction to anyone who wanted to build a mausoleum or burial vault. (Figure 11) *Concrete Monuments, Mausoleums and Burial Vaults* for example, contains directions for sizing individual crypts, instructions for using metal lath as reinforcement between the four inch thick walls that divided each crypt, how to replicate each box until the desired number of individual vaults is achieved, and how to make a beam and tackle system for lifting the coffins into place. The following excerpt explains construction of a crypt, and a figure illustrating the directions accompanies the text. "The mold for the crypt is easily made in a square box form, and this placed at the proper point upon the concrete for the shelf below same, and thus molds the partition walls and also the shelf above the crypt. This form must be made in sections, so it can be easily removed from the work..."⁸¹

Construction of a mausoleum involves not only crypts, but also a ventilation system which allows for gases to escape out of each crypt, while not causing foul orders on the outside of the building. In 1907, ten years before Miller began construction of his mausoleum, William I. Hood and John W. Chesrown, both of Norwalk, Ohio secured a patent that used a valve and piping system inside the crypts and mausoleum walls which served this ventilation purpose. Miller may have used components from that design in his mausoleum, as the plan shown in the patent and the description of the air passage system are similar to his own. (Figure 13A and B)

Joseph M. Miller's building is locally significant as a vernacular family mausoleum, which used reinforced concrete as a construction medium for its enduring properties, ensuring the protection of the interred. Concrete may have also been used for its versatility. It could be prepared, poured and shaped by one person; making it possible for Joseph Miller to build his mausoleum almost exclusively by himself. The Joseph M. Miller Mausoleum is distinctive to Johnson County and the surrounding area. The survey titled "One Hundred Years of Architectural Resources in Johnson County, Missouri", which was conducted in 1987, lists the Miller mausoleum as the only mausoleum in the county.⁸² A search for other large mausoleums built of reinforced concrete throughout Missouri, and immediate surrounding states, revealed buildings only found in public cemeteries that had been constructed by commercial companies. Some of those mausoleums in Missouri were being constructed in the 1910s in St. Louis, Kansas City, Cape Girardeau, and St. Joseph.⁸³ In surrounding states, the Oak Hill Cemetery

⁸¹ A.A. Houghton, *Concrete Monuments, Mausoleums and Burial Vaults*, 52.

⁸² Joy Stevenson, Roger Maserang and Tom Christopher, "One Hundred Years of Architectural Resources in Johnson County, Missouri," (Missouri Department of Natural Resources, Missouri State Historic Preservation Office, June 1987), 91.

⁸³ Ann Morris, "Sacred Green Space, A Survey of Cemeteries in St. Louis County,," Susan Jezak Ford, "Union Cemetery" National Register of Historic Places Nomination, April 19, 2016 (Washington D.C.: National Park Service, Department of the Interior); "The Temple of Rest" Mausoleum, Blog,

National Register of Historic Places
Continuation Sheet

Section number 8 Page 23

Miller, Joseph M., Mausoleum
Name of Property
Johnson County, Missouri
County and State
n/a
Name of multiple listing (if applicable)

Mausoleum in Lawrence, Kansas was constructed in 1917, and in Wichita, the Old Mission Mausoleum was built in 1918.⁸⁴ In Chicago, Illinois the Beecher Cemetery mausoleum was built in 1913.⁸⁵

Final Resting Place

Joseph Miller died in 1938 and Alice Miller died in 1942. Perpetual care of the mausoleum was left to their children, Fred and Elsie, and Lundy Miller, to be supported by proceeds from their land.⁸⁶ In accordance with his wishes, they were interred in the mausoleum, along with family members who passed before them. This included Joseph's parents, John D. Miller and Margaret A. Miller, who had been moved by him from the local Rock Springs Cemetery and interred in the front crypt room before 1934. He had also interred the small coffins of six of his children who had died in childhood. The first relative interred in the mausoleum immediately after death was his brother, Dr. Samuel P. Miller, who died in July of 1925.⁸⁷ His brother's vault also contained three small coffins of children that he and his wife, Dora B. (*nee* White) Miller, had lost in childhood.⁸⁸ Some of the other people interred were relatives of Fern (*nee* Haggard) Miller, William H. Miller, who was the step-brother of Joseph Miller, his sister-in-law, Dora Bell Miller, and a preacher and his wife who had long been associated with the family.⁸⁹ All told, twenty-three bodies were interred in the crypt vaults.

Joseph Miller put careful planning into his mausoleum, making sure that his family was gathered together in a single resting place. If a family member was not interred in the mausoleum, a stone nameplate secured to the walls of the front crypt room recorded that persons' name, birth, death and location of burial. (Photo 11) To further identify who was in the mausoleum, Miller moved the grave stones from original cemetery plots to the mausoleum. His parents' grave stone is set in the front southeast corner of the building, and four of the headstones for the children that had been moved to the mausoleum were incorporated as part of the wall construction. (Two are visible in Photo 12, Figure 8)

Unfortunately, Miller was not able to foresee changes that would affect the long term use of the mausoleum; one being that the size of coffins increased in the years after his death. Eventually,

advertisement reprinted from the *Daily Republican*, Dec. 1 1917, *Southeast Missourian*, (Cape Girardeau, MO), accessed July 5, 2017. <http://www.semissourian.com/blogs/flynch/entry/47594>; Barbara Turner, "Mora Mora Cemetery," National Register Nomination, 2006 (Washington D.C.: National Park Service, Department of the Interior).

⁸⁴ David G. Stuart, "Old Mission Mausoleum," National Register of Historic Places Nomination, May 21, 2009 (Washington D.C.: National Park Service, Department of the Interior).

⁸⁵ Kurt West Garner and Sandra Lee Thielman, "Beecher Mausoleum," National Register of Historic Places Nomination, Sept 18, 2013 (Washington D.C.: National Park Service, Department of the Interior).

⁸⁶ "Joseph M. Miller Trust", 1. The identity of Lundy Miller is unknown, it may his third child, Edwin Miller.

⁸⁷ Cranfill, *A Heritage to Cherish*, 231.

⁸⁸ Cranfill, *A Heritage to Cherish*, 231.

⁸⁹ Cranfill, *A Heritage to Cherish*, 231.

National Register of Historic Places
Continuation Sheet

Section number 8 Page 24

Miller, Joseph M., Mausoleum
Name of Property
Johnson County, Missouri
County and State
n/a
Name of multiple listing (if applicable)

the vaults proved to be too small to accommodate larger, new caskets. Attempts were made to chisel out parts of the vaults to enlarge them enough for modern caskets, but this was abandoned as a regular practice, and the mausoleum fell from use.⁹⁰ The last body placed in the mausoleum was that of his daughter-in-law and wife of Fred, Fern (*nee* Haggard) Miller, who died at the age of one hundred in 1982.⁹¹

In the 1950s Miller's children granted permission to the Holden Jaycees to use the surrounding property and a lake located in the central region of the 15.69 acres for recreational purposes.⁹² This local civic group erected a small privy and a picnic shelter in the 1980s to the southwest and northwest of the mausoleum. The privy and shelter remain only partially intact and are in very poor condition. (The concrete pad is the only part of the shelter remaining.) Descendants of Joseph M. Miller have had all the bodies once interred in the mausoleum exhumed and moved to the Holden Cemetery because the building is in need of repair and has long suffered from vandalism.⁹³

Carl Cranfill, great-grandson and executor of the Joseph M. Miller trust, has invested a great deal of time researching and writing about his family history and protecting the mausoleum. His work, *A Heritage to Cherish*, along with a collection of newspaper clippings and family documents, provided significant information for this nomination.⁹⁴ He is currently directing necessary repairs of the building and surrounding site. In 2017 Carl had brush and vines removed from the concrete walls, the front pillars have been reinforced with new layers of concrete and leaks in the roof are scheduled for repair. The work has helped to secure the structure and does not overtly affect the original design and look of the mausoleum.

Conclusion

The Joseph M. Miller Mausoleum is unique to Johnson County as a vernacular family mausoleum which displays construction methods that were described in reinforced concrete instruction manuals available to professional tradesmen and unskilled laborers at the turn of the twentieth century. Farmer, teacher and businessman, Joseph M. Miller was motivated to create his mausoleum by Judeo-Christian burial practices that originated in the Middle East, and an effort to avoid the thought of decay of his body after burial in a wet grave. Possibly inspired by the versatility of reinforced concrete as a construction medium, and by the rising popularity of large mausoleums in public cemeteries, Joseph was encouraged to use concrete as a building

⁹⁰ Sue Sterling, "Mausoleum May Haunt the County," *Daily Star-Journal* (Warrensburg, MO), Aug. 26 1993, n.p.; Cranfill, *A Heritage to Cherish*, 50.

⁹¹ Mausoleum vault namestones and records of Carl Cranfill.

⁹² Harris, "Mysterious Miller Mausoleum," n.p.

⁹³ Sue Sterling, "Heir plans to resurrect Miller Mausoleum as site public may visit," *Daily Star-Journal* (Warrensburg, MO), June 27, 2017, B1.

⁹⁴ Carl Cranfill Collection. The collections consists of various newspaper clippings, family photos, family documents and legal paperwork collected between ca. 2005 and 2017.

National Register of Historic Places
Continuation Sheet

Section number 8 Page 25

Miller, Joseph M., Mausoleum
Name of Property
Johnson County, Missouri
County and State
n/a
Name of multiple listing (if applicable)

material that would protect himself and his family in their final resting place for a long time. It retains original materials, plans, workmanship and location. The only changes of note are reinforcement of the front pillars and two side piers with additional layers of concrete. Two of the pillars on the south side of the façade had been repaired in the 1970s, and following the recent repair of the north pillars, the front is once again symmetrical and proportional in appearance. The building is intact and strongly conveys its design values, and a sense of its time and place.

National Register of Historic Places
Continuation Sheet

Section number 9 Page 26

Miller, Joseph M., Mausoleum
Name of Property
Johnson County, Missouri
County and State
n/a
Name of multiple listing (if applicable)

Sources

"A National Treasure." Erie Canalway, National Heritage Corridor. Accessed July 18, 2017.
<https://eriecanalway.org/learn/history-culture>.

"Certificate of Survey, Section 3, Township 45 North, Range 28 West." Eagle Pointe Surveying, LLC. Johnson County Recorder of Deeds, Instr# 398180, Book: 13, Page 151, May 12, 2017.

Cockrell, Ewing. *History of Johnson County Missouri*. Topeka: Historical Publishing Co., 1918.

Corbett, Katherine T. "Bellefontaine Cemetery, St. Louis City of the Dead." *Gateway Heritage* 2(1991): 58-67.

Carl Cranfill Collection. Collection of newspaper clippings, family papers and legal documents for Miller family and mausoleum.

Cranfill, Carl. *A Heritage to Cherish*. Edited by Lisa Ailshie. Self-published, 2016.

Cranfill, Carl, phone interview with Andrea Herries, July 11, 2017.

Cranfill, Carl, interview with Deb Sheals, June 22, 2017.

Dudley, Ruth. "Holden Mausoleum Perpetuates Founder's Memory –J.M. Miller." *Daily Star-Journal* (Warrensburg, MO), Dec. 21, 1967.

Edwards, Stephanie. "Miller Mausoleum Still a Fascination." *Holden Image* (Holden, MO), June 4, 2012.

"Family Tomb is Built by Missouri Farmer on His Land." *Weekly Kansas City Star*, ca. 1934. Johnson County Historical Society, Warrensburg, MO. Miller Mausoleum Vertical File.

Ford, Susan Jezak. "Union Cemetery." National Register of Historic Places Nomination, April 19, 2016. Washington D.C.: National Park Service, Department of the Interior.

Fowler, O.S. *A Home for All or The Gravel Wall and Octagon Mode of Building*. New York: Fowlers & Wells, 1854. Google Books. Accessed July 7, 2017.
https://books.google.com/books/about/A_Home_for_All.html?id=jF9JAQAAIAAJ.

Garner, Kurt West and Sandra Lee Thielman. "Beecher Mausoleum." National Register of Historic Places Nomination, Sept 18, 2013. Washington D.C.: National Park Service, Department of the Interior.

"General Highway Map Johnson County." MoDot Office of Transportation and Planning, 2005. Accessed July 6, 2017.

"Good Roads." *Holden Enterprise*, Jan. 31, 1914.

National Register of Historic Places
Continuation Sheet

Section number 9 Page 27

Miller, Joseph M., Mausoleum
Name of Property
Johnson County, Missouri
County and State
n/a
Name of multiple listing (if applicable)

Google Earth. Accessed July 17, 2017.

Harris, Bob. "Mysterious Miller Mausoleum." *Daily Star-Journal* (Warrensburg, MO), Jan. 22, 1975. Johnson County Historical Society, Warrensburg, MO. Miller Mausoleum Vertical File.

Hood, William I. and John W. Chestown. Burial-Crypt, Patent 858.070. June 25, 1907. *Official Gazette of the United States Patent Office* 2(1907): 3104. Hathi Trust. Accessed July 3, 2017. <https://babel.hathitrust.org/cgi/pt?id=wu.89119133841;view=1up;seq=1514;size=150>Slaton, Amy E.

Houghton, A.A. *Concrete Monuments, Mausoleums and Burial Vaults*. New York: Norman W. Henley Publishing Co., 1911. Google Books. Accessed July 3, 2017. <https://books.google.com/books?id=2aJXAAAAYAAJ&pg=RA1-PA13&dq=concrete+monuments+mausoleums+and+burial+vaults&hl=en&sa=X&ved=>

Jenkins, M.C. "Post Cineres Gloriam Ventit." *National Magazine* 40 (Jan. 1914): 641-651. Google Books. Accessed July 3, 2017. <https://play.google.com/books/reader?id=Fs1OQAAMAAJ&printsec=frontcover&output=reader&hl=en&pg=GBS.PA636>.

"J.M. Miller of Pittsville, is having a residence erected in Holden." *Holden Enterprise (Holden, MO)* Sept 16, 1915. Trails Regional Library, Warrensburg, MO.

"Joseph M. Miller is erecting a burial vault at his premises north of town." *Warrensburg Standard-Herald* (Warrensburg, MO) July 13, 1917. Trails Regional Library, Warrensburg, MO.

"Joseph M. Miller Trust", September 20, 1937. A copy has been made available through Carl Cranfill, executor of the trust and great-great grandson of Joseph M. Miller.

Keister, Douglas. *Stories in Stone, A Field Guide to Cemetery Symbolism and Iconography*. Salt Lake City: Gibbs, Smith, 2004.

Lewis, Myron H and Albert H. Chandler. *Popular Hand Book For Cement and Concrete Users*. New York: Norman W. Henley Publishing Company, 1911. Google Books. Accessed July 7, 2017. <https://books.google.com/books?id=TYM0AAAAMAAJ&printsec=frontcover&dq=popular+hand+book+for+cement+and+concrete+users&hl=en&sa=X&ved>

Morris, Ann. "Sacred Green Space, A Survey of Cemeteries in St. Louis County." Missouri State Historic Preservation Office, 2000. Accessed July 2, 2017. <http://dnr.mo.gov/shpo/survey/SLAS032-R.pdf>.

1911 Catalogue of Good, Practical Books. New York: Norman W. Henley Publishing Company, 1911. Google Books.

National Register of Historic Places
Continuation Sheet

Section number 9 Page 28

Miller, Joseph M., Mausoleum
Name of Property
Johnson County, Missouri
County and State
n/a
Name of multiple listing (if applicable)

"Population, Holden MO." Population.us. Accessed July 26, 2017.
<http://population.us/mo/holden/>

Slaton, Amy E., Paul E. Gaudette, William G. Hime and James D. Connolly. "Reinforced Concrete." In *Twentieth-Century Building Materials, History and Conservation*, edited by Thomas C. Jester, 94-107. New York: McGraw-Hill, 1995.

Sterling, Sue. "Heir plans to resurrect Miller Mausoleum as site public may visit." *Daily Star-Journal* (Warrensburg, MO), June 27, 2017.

Sterling, Sue. "Miller Built Mausoleum for Family Resting Place." *Daily Star-Journal* (Warrensburg, MO), Aug. 26 1993.

Sterling, Sue. "Mausoleum May Haunt the County." *Daily Star-Journal* (Warrensburg, MO), Aug. 26 1993.

Stevenson, Joy, Roger Maserang and Tom Christopher. "One Hundred Years of Architectural Resources in Johnson County, Missouri." Missouri Department of Natural Resources, Missouri State Historic Preservation Office, June 1987.

Stowe, Christi. "Tragedy mars Christmas holiday for Holden family when home burns." Holden newspaper (Holden, MO), December 2004. Clipping provided by Cochran family of Holden, MO.

Stuart, David G. "Old Mission Mausoleum." National Register of Historic Places Nomination, May 21, 2009. Washington D.C.: National Park Service, Department of the Interior.

Turner, Barbara. "Mora Mora Cemetery." National Register Nomination, 2006. Washington D.C.: National Park Service, Department of the Interior.

"The Temple of Rest" Mausoleum. Blog. Advertisement reprinted from the *Daily Republican*, Dec. 1 1917. *Southeast Missourian*, (Cape Girardeau, MO) Accessed July 5, 2017.
<http://www.semissourian.com/blogs/flynch/entry/47594>.

National Register of Historic Places
Continuation Sheet

Section number 10 Page 29

Miller, Joseph M., Mausoleum
Name of Property
Johnson County, Missouri
County and State
n/a
Name of multiple listing (if applicable)

Verbal Boundary Description

Beginning at the southeast corner of the Northeast $\frac{1}{4}$ of the Southeast $\frac{1}{4}$ of Section 3, Twp 45 N, Range 28 W, proceed north along the east line of said section 257.16 feet to the Point of Beginning. Continue north along the east section line 250 feet, then west 250 feet, then south 250 feet, and finally east 250 feet to the point of beginning.

The boundaries are shown as a heavy dashed line in Figure 3; they include the mausoleum and surrounding lawn.

Boundary Justification

The nominated property is located in the northeast corner of a 15.69-acre parcel of land that includes the mausoleum and undeveloped land that was intended to serve as a cemetery. (The cemetery was never developed, and no other burials have occurred on the 15.69 parcel outside the mausoleum.) A trust deed created by Joseph M. Miller in 1937 set aside a cemetery at this location, plus a "tract of land 250 feet east and west by 250 feet north and south on which is located the Joseph M. Miller Mausoleum and the residence wherein I live."⁹⁵ (The residence is no longer extant.) Although the trust document did not identify the exact location of the mausoleum parcel in relation to the larger tract, it set a precedent for the size of the nominated property.

⁹⁵ "Joseph M. Miller Trust", September 20, 1937. A copy has been made available through Carl Cranfill, executor of the trust and great-great grandson of Joseph M. Miller.

National Register of Historic Places
Continuation Sheet

Section number Figures Page 30

Miller, Joseph M., Mausoleum
Name of Property
Johnson County, Missouri
County and State
n/a
Name of multiple listing (if applicable)

1. Aerial photo map from Google Earth, with a scale bar.

Accessed July 24, 2017.

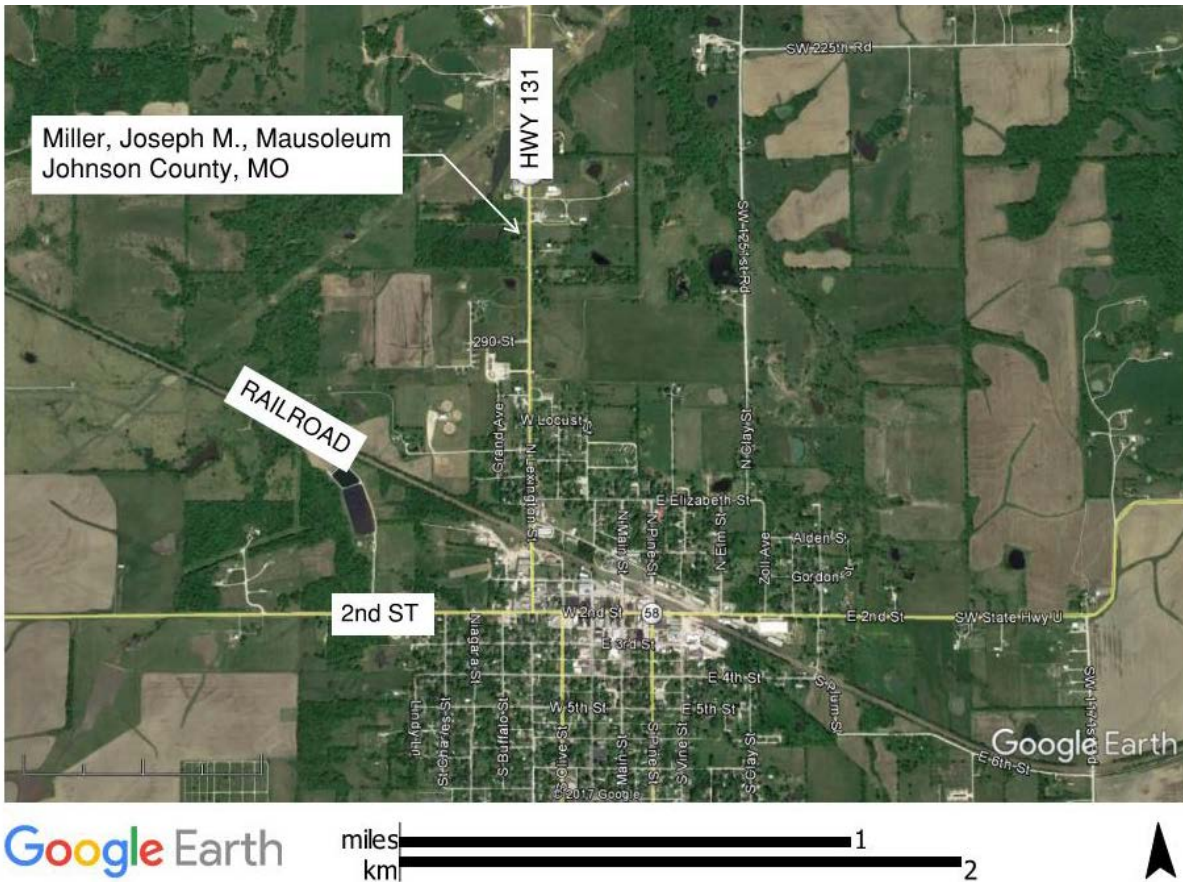

National Register of Historic Places
Continuation Sheet

Section number Figures Page 31

Miller, Joseph M., Mausoleum
Name of Property
Johnson County, Missouri
County and State
n/a
Name of multiple listing (if applicable)

2. Aerial photo map of the area, from Google Earth with Coordinates.

Accessed July 24, 2017.



Miller, Joseph M., Mausoleum
.8 mile north of jct. MO HWY 131 and 2nd St. Holden, MO 64040 Latitude: 38.730246° Longitude: -93.993103°



National Register of Historic Places
Continuation Sheet

Section number Figures Page 32

Miller, Joseph M., Mausoleum
Name of Property
Johnson County, Missouri
County and State
n/a
Name of multiple listing (if applicable)

3. Site Map.

Map created by Deb Sheals July 2017 with site survey for East 1/2 of Section 3-45-28 West, by Eagle Pointe Surveying, LLC (Johnson County Recorder of Deeds Instr# 398180, Book: 13, Page 151, May 12, 2017) with Google Earth Aerial Capture Overlay.

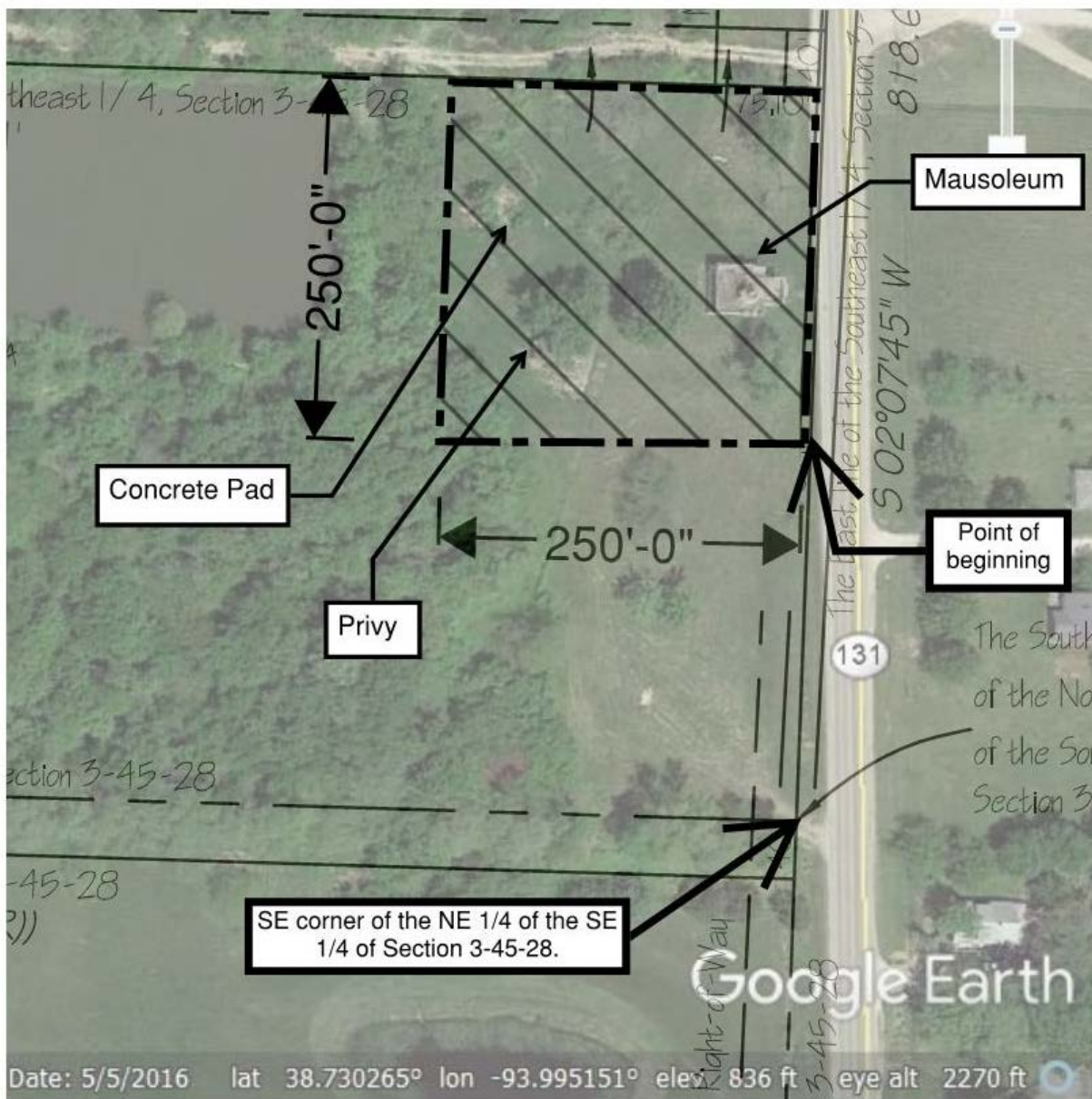

National Register of Historic Places
Continuation Sheet

Section number Figures Page 33

Miller, Joseph M., Mausoleum
----- Name of Property
Johnson County, Missouri
----- County and State
n/a
----- Name of multiple listing (if applicable)

4. Photo ca.1970 of horse and rider, low stone wall and south side of mausoleum on Miller property.

Photo courtesy of Carl Cranfill and Cochran Family.



National Register of Historic Places
Continuation Sheet

Section number Figures Page 34

Miller, Joseph M., Mausoleum
Name of Property
Johnson County, Missouri
County and State
n/a
Name of multiple listing (if applicable)

5. First Floor Plan.

Created by Andrea Herries July 2017.

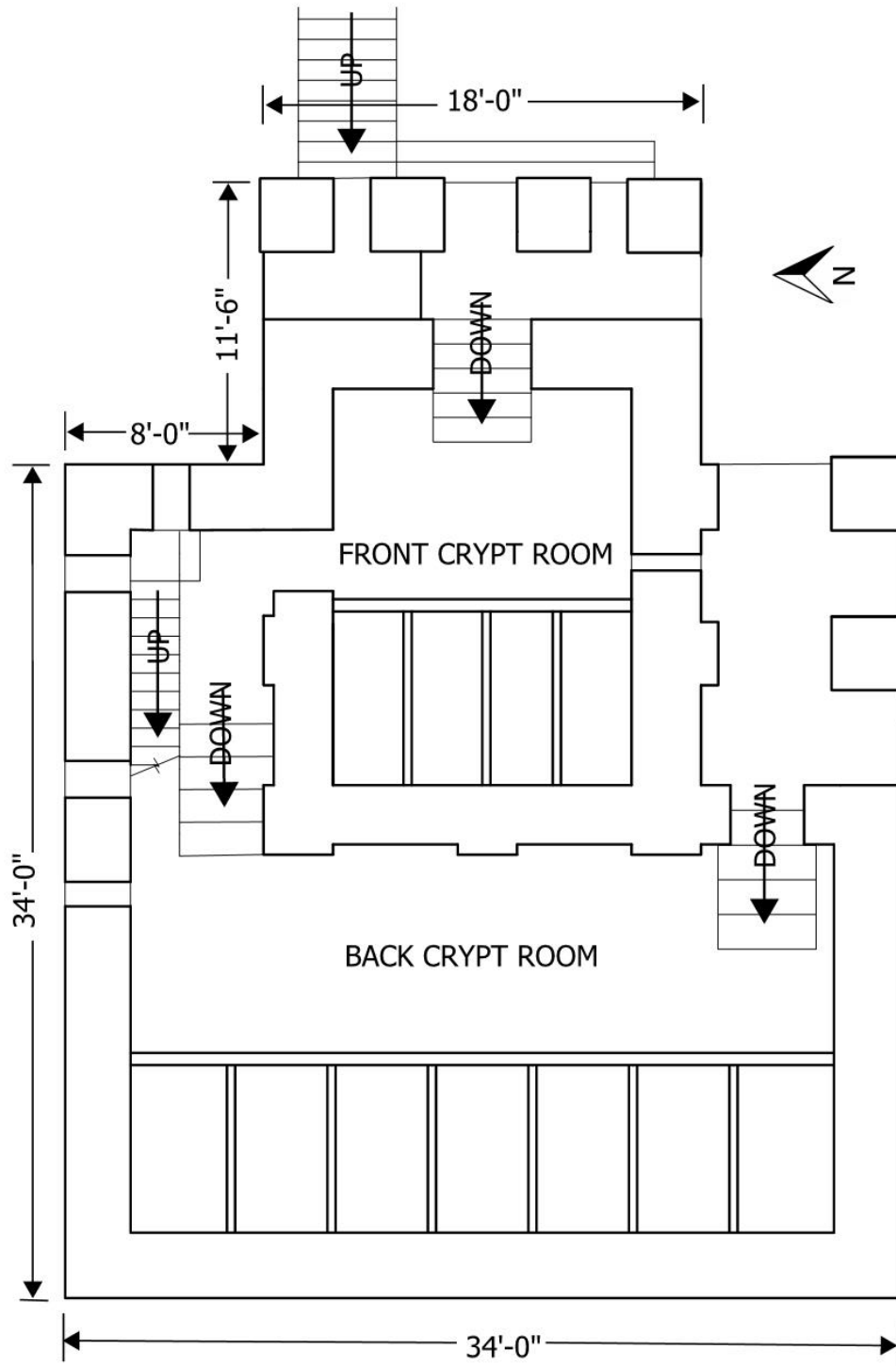

National Register of Historic Places
Continuation Sheet

Section number Figures Page 35

Miller, Joseph M., Mausoleum

Name of Property
Johnson County, Missouri

County and State
n/a

Name of multiple listing (if applicable)

6. Second Floor Plan.

Created by Andrea Herries July 2017.

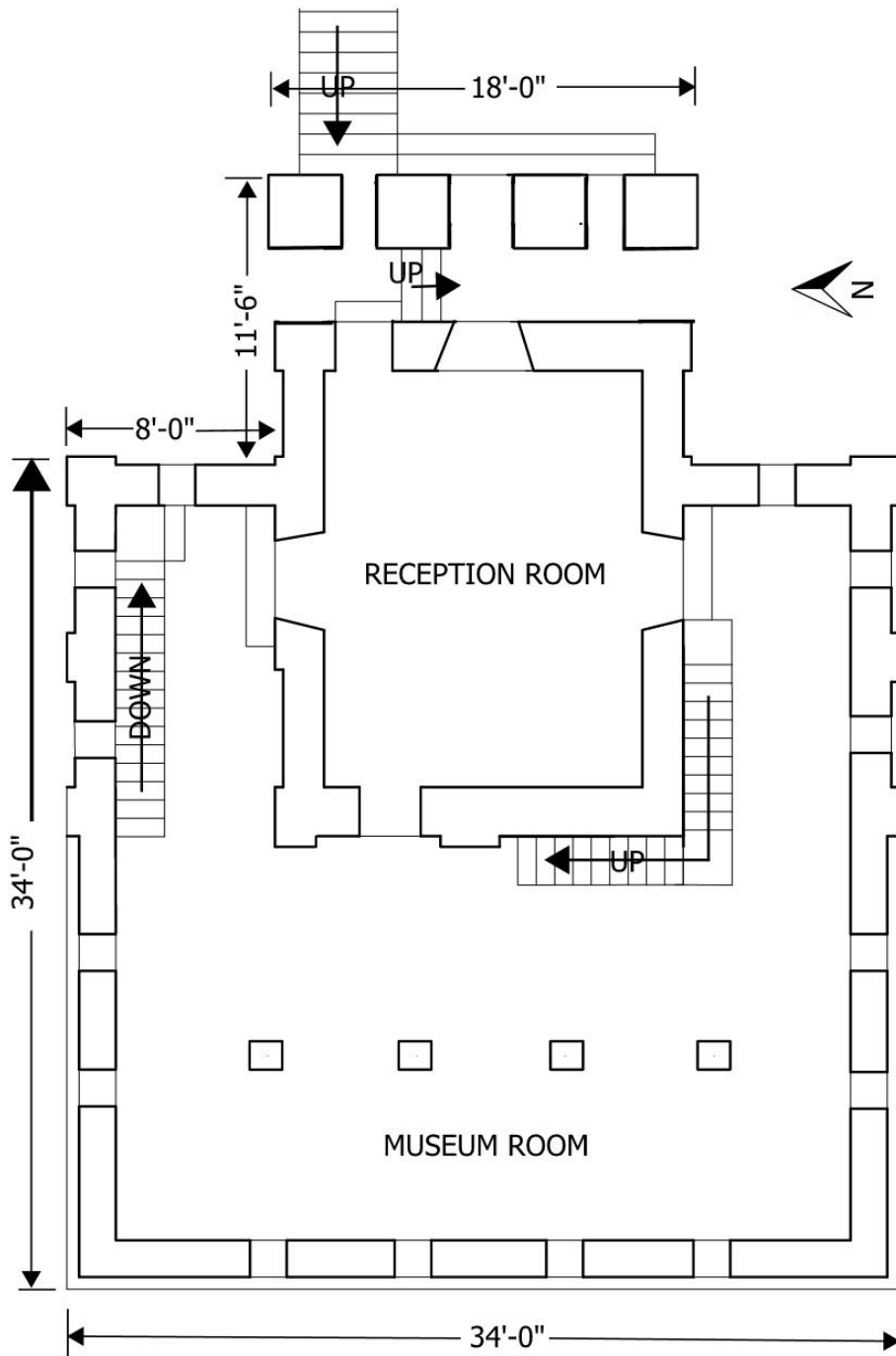

National Register of Historic Places
Continuation Sheet

Section number Figures Page 36

Miller, Joseph M., Mausoleum

Name of Property

Johnson County, Missouri

County and State

n/a

Name of multiple listing (if applicable)

7. Photo of Laura Alice Miller, Fred Miller, Joseph Marion Miller ca. 1881.

Photo courtesy of Carl Cranfill.



National Register of Historic Places
Continuation Sheet

Section number Figures Page 37

Miller, Joseph M., Mausoleum

Name of Property
Johnson County, Missouri

County and State
n/a

Name of multiple listing (if applicable)

8. Photo collage with Joseph M. Miller and images of the mausoleum ca. 1934.

"Family Tomb is Built by Missouri Farmer on His Land." *Weekly Kansas City Star*, ca. 1934.
Johnson County Historical Society, Warrensburg, MO. Miller Mausoleum Vertical File.

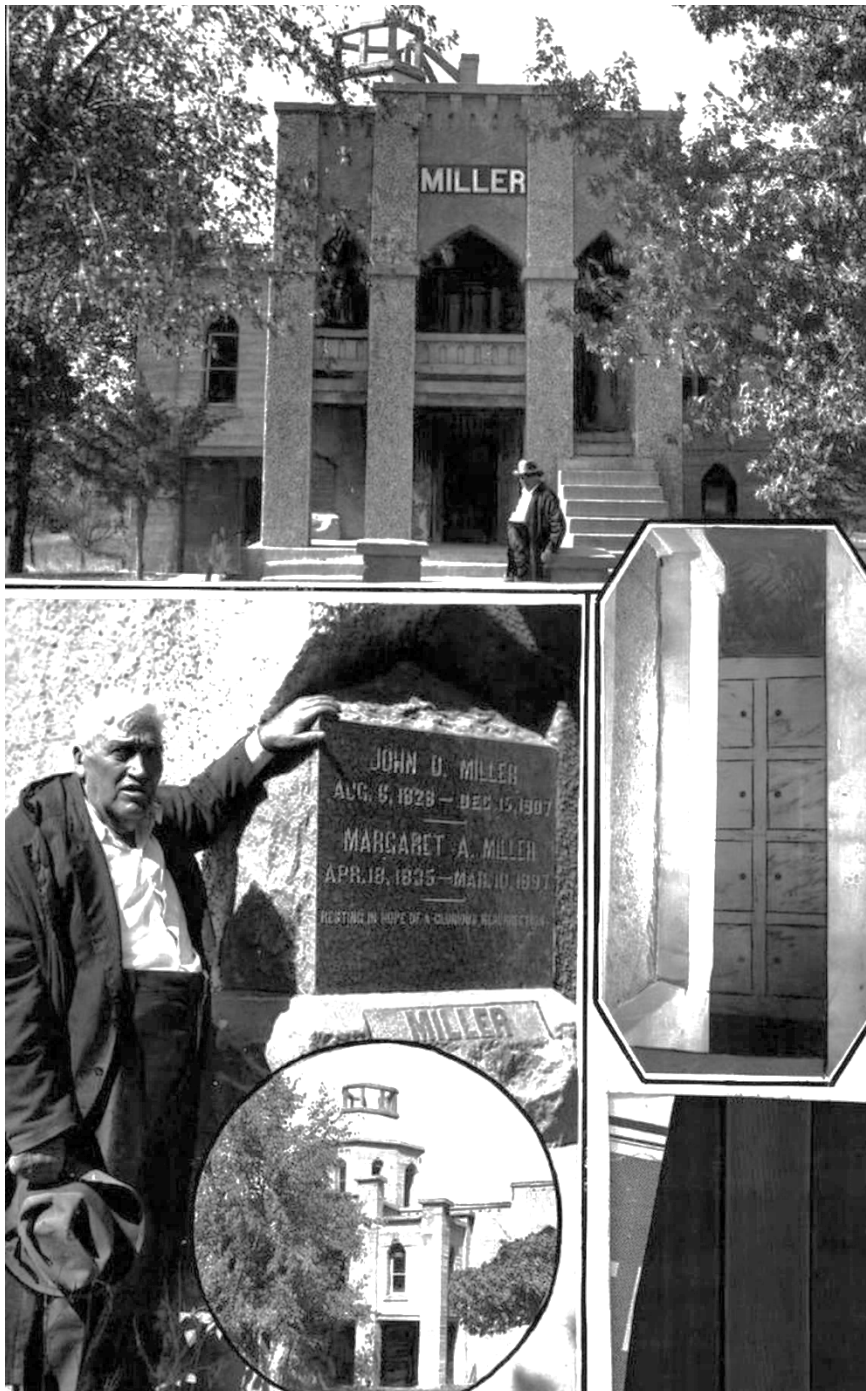

National Register of Historic Places
 Continuation Sheet

Section number Figures Page 38

Miller, Joseph M., Mausoleum

Name of Property
Johnson County, Missouri

County and State
n/a

Name of multiple listing (if applicable)

9. Types of wall forms for concrete construction.

Myron H. Lewis and Albert H. Chandler, *Popular Hand Book For Cement and Concrete Users* (New York: Norman W. Henley Publishing Company, 1911), 68-70, Google Books, accessed July 6, 2017.

Movable Wall Forms

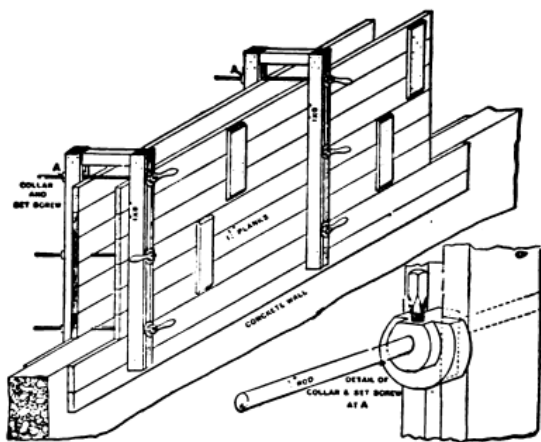

FIG. 23.—Movable Wall Forms.

Forms Made of Studding and Matched Boards

1. Where the boards are nailed to the inside of the studding and the form erected as a unit.

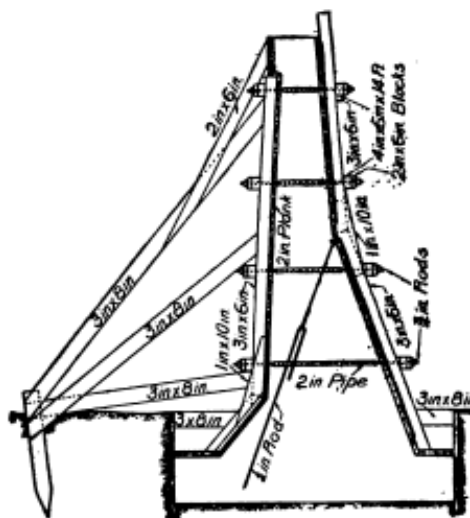

FIG. 20.—Forms for Reinforced Concrete Retaining Wall.

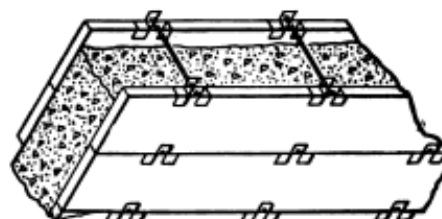

FIG. 21.—The Farrel Plank Holder.

2. Where the studding is erected and braced, and the boards set one at a time without nailing. This design is much more convenient for pouring, as the concrete is only the width of a board below the top of the form, which is built up as the work proceeds.

National Register of Historic Places
Continuation Sheet

Section number Figures Page 39

Miller, Joseph M., Mausoleum
Name of Property
Johnson County, Missouri
County and State
n/a
Name of multiple listing (if applicable)

10. Diagram for correct placement of metal reinforcement in girder construction.

Myron H. Lewis and Albert H. Chandler. *Popular Hand Book For Cement and Concrete Users* (New York: Norman W. Henley Publishing Company, 1911), 172, Google Books, accessed July 6, 2017.

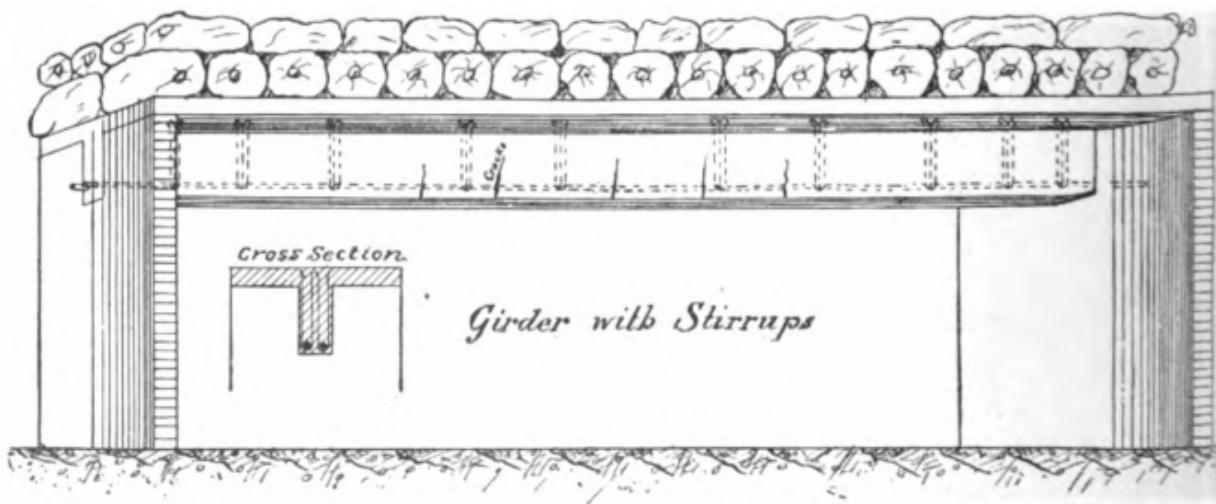

FIG. 49.—Test of Girder under Load with and without Stirrups. (Hennebique.)

National Register of Historic Places
Continuation Sheet

Section number Figures Page 40

Miller, Joseph M., Mausoleum
Name of Property
Johnson County, Missouri
County and State
n/a
Name of multiple listing (if applicable)

11. Cover of *Concrete Monuments, Mausoleums and Burial Vaults*.

A.A. Houghton, *Concrete Monuments, Mausoleums and Burial Vaults*, (New York: Norman W. Henley Publishing Co., 1911) Cover Page, Google Books, Accessed July 3, 2017.

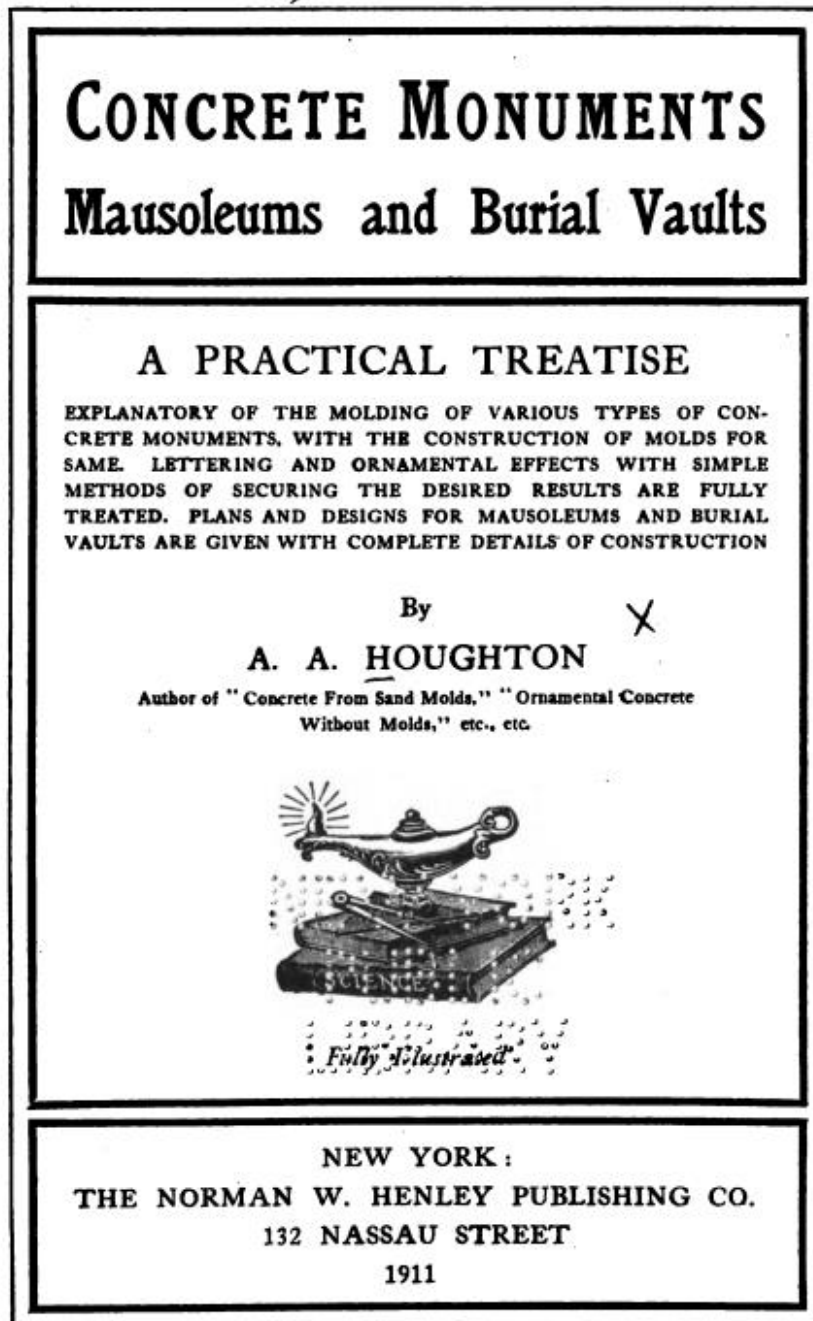

National Register of Historic Places
Continuation Sheet

Section number Figures Page 41

Miller, Joseph M., Mausoleum

Name of Property
Johnson County, Missouri

County and State
n/a

Name of multiple listing (if applicable)

12. Diagram for molding indented, inlaid and projecting letters as shown in *Concrete Monuments, Mausoleums and Burial Vaults*.

A.A. Houghton, *Concrete Monuments, Mausoleums and Burial Vaults*, (New York: Norman W. Henley Publishing Co., 1911) 41, Google Books, accessed July 3, 2017.

MAUSOLEUMS AND BURIAL VAULTS

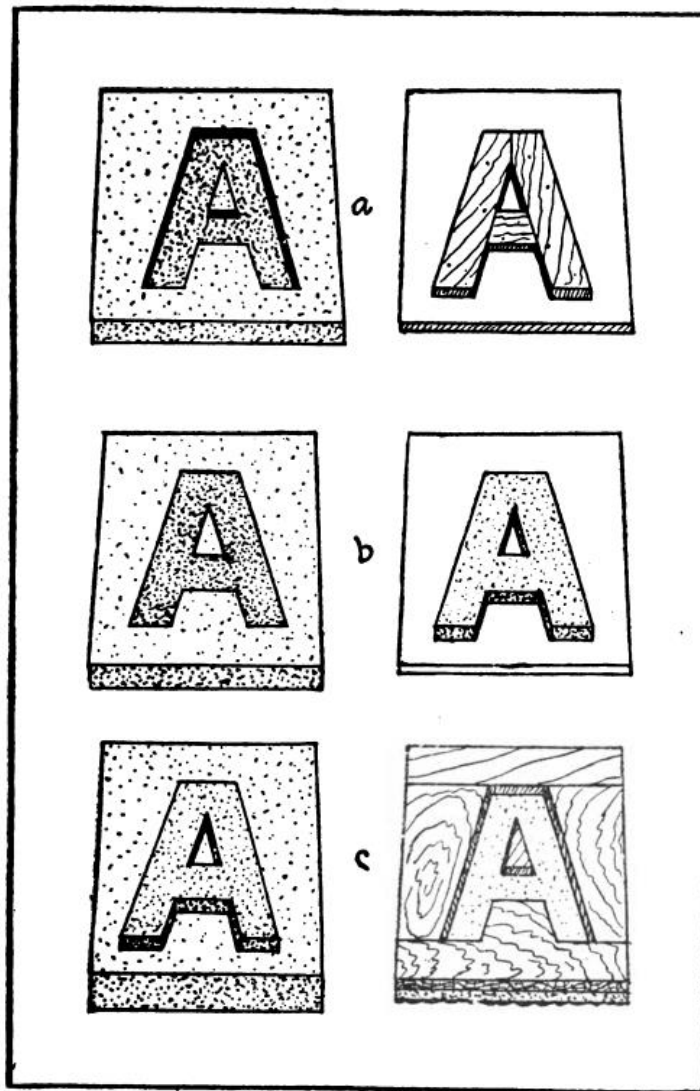

FIG. 10.—Molding indented ; inlaid and projecting letters.

National Register of Historic Places
Continuation Sheet

Section number Figures Page 42

Miller, Joseph M., Mausoleum
Name of Property
Johnson County, Missouri
County and State
n/a
Name of multiple listing (if applicable)

13. A. Burial-Crypt, Patent 858.070, June 25, 1907.

Burial-Crypt, patent 858.070, June 25, 1907, Hathi Trust, accessed June 3, 2017.

B. Image of vault venting system from Joseph M. Miller Mausoleum, Front Crypt Room.

Photo by Deb Sheals, June 21, 2017.

A

Figure 13 A shows the plan from the 1907 "Burial-Crypt" patent, which has a reception hallway, like Miller's, and pipes and valves along the front and back of the crypts, identified by the numbers 5 and 7. Figure 13 B shows the piping system at the front of Miller's crypts.

858,070. BURIAL-CRYPT. WILLIAM I. HOOD, Norwalk, Ohio, assignor of one-half to John W. Chesrown, Norwalk, Ohio. Filed Mar. 14, 1907. Serial No. 362,399.

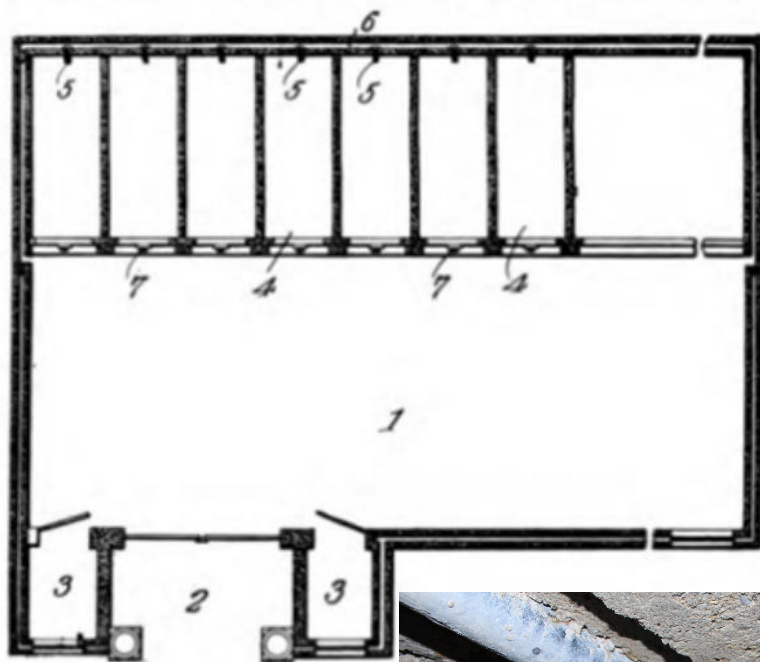

B



National Register of Historic Places
Continuation Sheet

Section number Photos Page 43

Miller, Joseph M., Mausoleum

Name of Property
Johnson County, Missouri

County and State
n/a

Name of multiple listing (if applicable)

Photo Key. Exterior and First Floor.

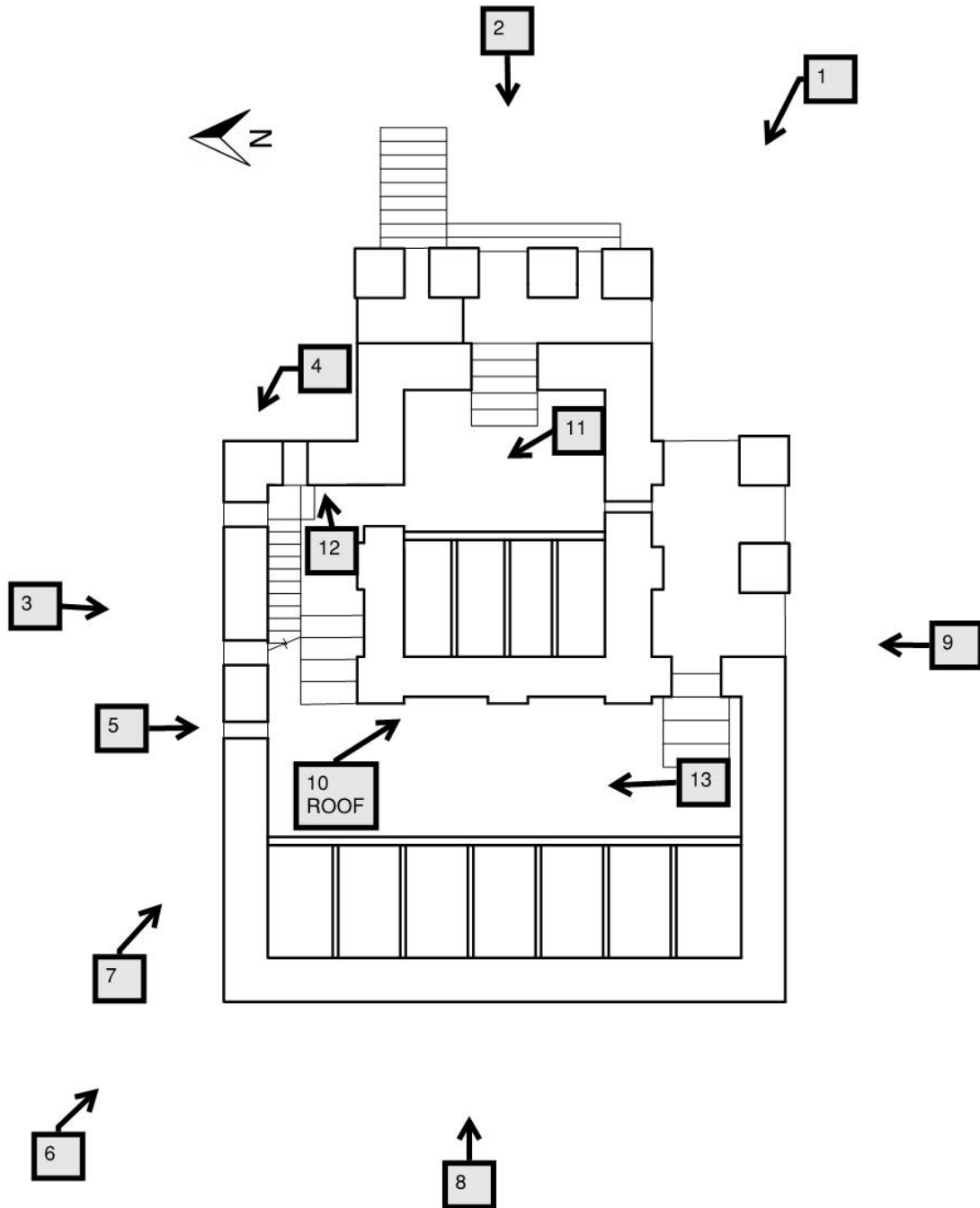

National Register of Historic Places
Continuation Sheet

Section number Photos Page 44

Miller, Joseph M., Mausoleum
Name of Property
Johnson County, Missouri
County and State
n/a
Name of multiple listing (if applicable)

Photo Key. Second Floor.

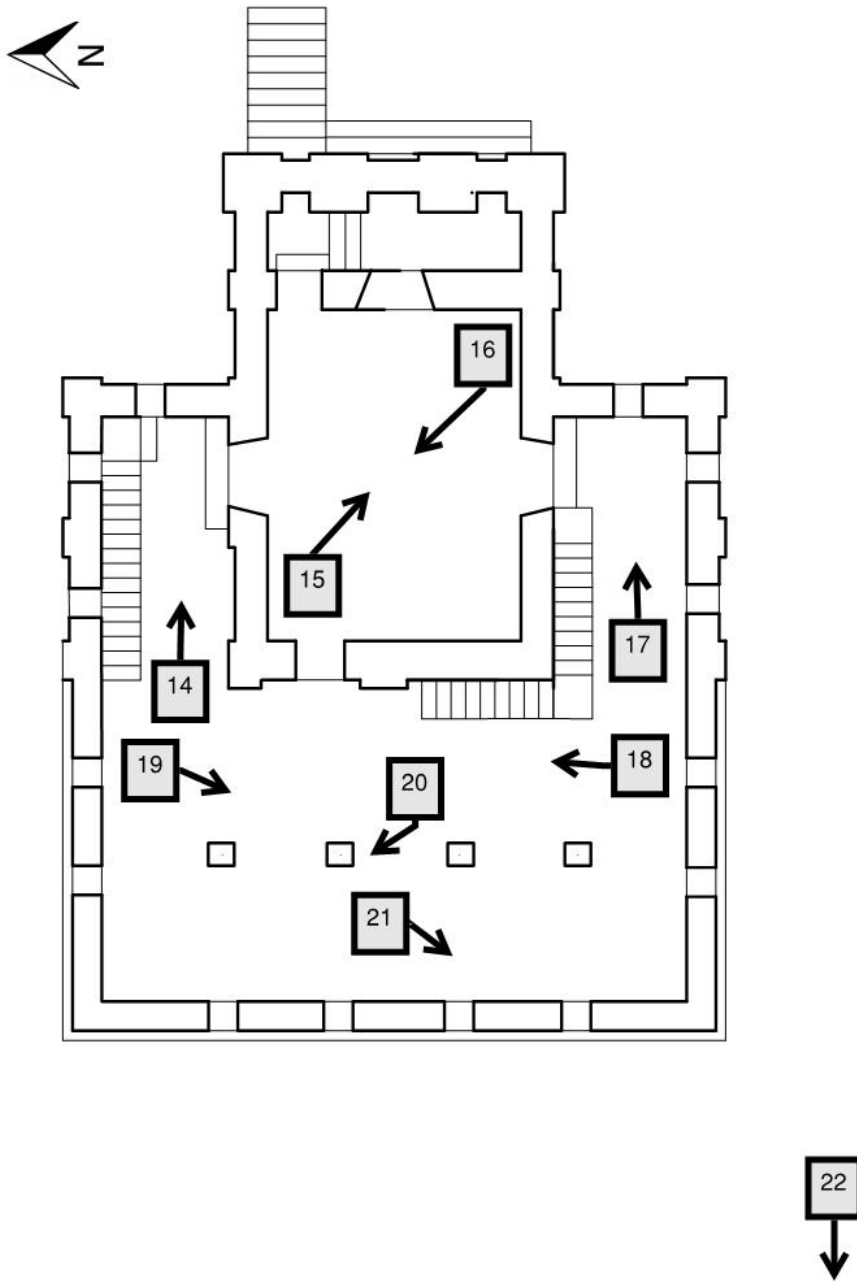

National Register of Historic Places
Continuation Sheet

Section number Photos Page 45

Miller, Joseph M., Mausoleum
Name of Property
Johnson County, Missouri
County and State
n/a
Name of multiple listing (if applicable)

1 of 22: Southeast Corner. Camera looking northwest.



2 of 22: Façade, East side. Camera looking west.



National Register of Historic Places
Continuation Sheet

Section number Photos Page 46

Miller, Joseph M., Mausoleum
Name of Property
Johnson County, Missouri
County and State
n/a
Name of multiple listing (if applicable)

3 of 22: North Side. Camera looking south.



4 of 22: Cornice and Roof Detail at Upper Northeast Corner. Camera looking northwest.



National Register of Historic Places
Continuation Sheet

Section number Photos Page 47

Miller, Joseph M., Mausoleum
Name of Property
Johnson County, Missouri
County and State
n/a
Name of multiple listing (if applicable)

5 of 22: Window Detail, North Side. Camera looking south.



6 of 22: Northwest Corner. Camera looking southeast.



National Register of Historic Places
Continuation Sheet

Section number Photos Page 48

Miller, Joseph M., Mausoleum
Name of Property
Johnson County, Missouri
County and State
n/a
Name of multiple listing (if applicable)

7 of 22: Cornice and Upper Wall Detail, Northwest Corner. Camera looking southeast.



8 of 22: Back, West Side. Camera looking east.



National Register of Historic Places
Continuation Sheet

Section number Photos Page 49

Miller, Joseph M., Mausoleum

Name of Property
Johnson County, Missouri

County and State
n/a

Name of multiple listing (if applicable)

9 of 22: South Side. Camera looking north.



10 of 22: Domed Cupola with Observation Platform and Stairs, Roof. Camera looking southeast.



National Register of Historic Places
Continuation Sheet

Section number Photos Page 50

Miller, Joseph M., Mausoleum
Name of Property
Johnson County, Missouri
County and State
n/a
Name of multiple listing (if applicable)

11 of 22: Front Crypt Room, First Floor. Camera looking northwest.



12 of 22: Lower East Wall Detail, First Floor North Hall. Camera looking east.



National Register of Historic Places
Continuation Sheet

Section number Photos Page 51

Miller, Joseph M., Mausoleum

Name of Property
Johnson County, Missouri

County and State
n/a

Name of multiple listing (if applicable)

13 of 22: Back Crypt Room, First Floor. Camera looking north.



14 of 22: North Hall, Second Floor. Camera looking east.



National Register of Historic Places
Continuation Sheet

Section number Photos Page 52

Miller, Joseph M., Mausoleum

Name of Property
Johnson County, Missouri

County and State
n/a

Name of multiple listing (if applicable)

15 of 22: Reception Room, Second Floor. Camera looking southeast.



16 of 22: Reception Room, Second Floor. Camera looking northwest.



National Register of Historic Places
Continuation Sheet

Section number Photos Page 53

Miller, Joseph M., Mausoleum

Name of Property

Johnson County, Missouri

County and State

n/a

Name of multiple listing (if applicable)



17 of 22: South Hall, Second Floor. Camera looking east.



18 of 22: Stairs to Cupola and Roof, Museum Room, Second Floor. Camera looking north.

National Register of Historic Places
Continuation Sheet

Section number Photos Page 54

Miller, Joseph M., Mausoleum

Name of Property
Johnson County, Missouri

County and State
n/a

Name of multiple listing (if applicable)

19 of 22: Museum Room, Second Floor. Camera looking southwest.



20 of 22: Ceiling Detail, Museum Room, Second Floor. Camera looking up.



National Register of Historic Places
Continuation Sheet

Section number Photos Page 55

Miller, Joseph M., Mausoleum

Name of Property
Johnson County, Missouri

County and State
n/a

Name of multiple listing (if applicable)

21 of 22: Interior Window Detail, Museum Room, Second Floor. Camera looking southwest.



22 of 22: Privy, Southwest of Mausoleum. Camera looking west.





SMILE
FOR ALL THE
CAMERAS

PRIVATE
PROPERTY
NO TRESPASSING

PRIVATE
PROPERTY
NO TRESPASSING

27.07.2017



MILLER

PRIVATE
PROPERTY
NO TRESPASSING

STL

21.07.2017



21.07.2017













SMILE
YOU'RE ON
CAMERA

PRIVATE
PROPERTY

21.07.2017



W. D. MILLER
1865-1950.29.1950

DR. W. H. MILLER
OF WASHINGTON
JULY 17 1864-DEC 1913

Small white paper label with illegible text.

Grid-patterned marble panel.

Grid-patterned marble panel.

Marble panel with a handle.

Marble panel with a handle.

JOHN T. MILLER
1828-1907

MEMORIAL OF
SARAH EDITHVILLE
BORN [illegible]
DIED [illegible]
AUGUST 18 [illegible]
18 [illegible]

MEMORIAL OF
HEZEKIAH MILLERSON
BORN [illegible]
DIED [illegible]
PARENTS OF [illegible]

Marble panel with a handle.

20.07.2017



LORAN E.

SON OF

J. W. & A. A.

MILLEN

DECEASED

APRIL 1888

AGE 20 YEARS

1888

1888

1888

1888

1888

1888

1888

1888

1888

1888

1888

1888

1888

1888

1888

1888

1888

1888

1888

1888







25.04.2017



PRIVATE
PROPERTY
NO TRESPASSING







20.07.2017



20.07.2017





25.04.2017

UNITED STATES DEPARTMENT OF THE INTERIOR
NATIONAL PARK SERVICE

NATIONAL REGISTER OF HISTORIC PLACES
EVALUATION/RETURN SHEET

Requested Action:

Property Name:

Multiple Name:

State & County:

Date Received: 12/14/2017 Date of Pending List: Date of 16th Day: Date of 45th Day: 1/29/2018 Date of Weekly List: 2/2/2018

Reference number:

Nominator:

Reason For Review:

Accept Return Reject 1/29/2018 Date

Abstract/Summary Comments:

Recommendation/ Criteria

Reviewer Edson Beall Discipline Historian

Telephone _____ Date _____

DOCUMENTATION: see attached comments : No see attached SLR : No

If a nomination is returned to the nomination authority, the nomination is no longer under consideration by the National Park Service.



Memorandum

Date: December 4, 2017

To: J. Paul Loether, National Register of Historic Places

From: Mike Sutherland, Deputy SHPO

Subject: **Joseph M. Miller Mausoleum, Holden vic., Johnson County, MO, National Register Nomination**



Our state review board, the Missouri Advisory Council on Historic Preservation, approved the above nomination on **November 3, 2017**. All owners and appropriate elected public officials were notified and provided at least thirty (30) days to comment on the above proposed nomination in accordance with Section 36CFR60.6, interim regulations, using the exact notification format recommended by the National Register. **The enclosed disc contains the true and correct copy of the nomination to the National Register of Historic Places.**

Please find enclosed the following documentation:

- 1 CD with original National Register of Historic Places registration form
- Multiple Property Documentation Form
- Photographs
- 1 CD with electronic images
- Original USGS map(s)
- 2 Piece(s) of correspondence (cover letter and signature page)
- Other: _____

Comments:

- Please ensure that this nomination is reviewed
- The enclosed owner objection(s) do _____ do not _____ constitute a majority of property owners.
- Other: _____