

United States Department of the Interior  
National Park Service

National Register of Historic Places  
Registration Form

This form is for use in nominating or requesting determinations for individual properties and districts. See instructions in *How to Complete the National Register of Historic Places Registration Form* (National Register Bulletin 16A). Complete each item by marking "x" in the appropriate box or by entering the information requested. If an item does not apply to the property being documented, enter "N/A" for "not applicable." For functions, architectural classification, materials, and areas of significance, enter only categories and subcategories from the instructions. Place additional entries and narrative items on continuation sheets (NPS Form 10-900a). Use a typewriter, word processor, or computer, to complete all items.

1. Name of Property

historic name Linwood Plantation Manager's House

other names/site number \_\_\_\_\_

2. Location

street & number five miles southeast of Newellton on LA Hwy 608 N/A not for publication

city or town Newellton  vicinity

state Louisiana code LA county Tensas code 107 zip code 71357

3. State/Federal Agency Certification

As the designated authority under the National Historic Preservation Act, as amended, I hereby certify that this  nomination  request for determination of eligibility meets the documentation standards for registering properties in the National Register of Historic Places and meets the procedural and professional requirements set forth in 36 CFR Part 60. In my opinion, the property  meets  does not meet the National Register criteria. I recommend that this property be considered significant  nationally  statewide  locally. ( See continuation sheet for additional comments.)

*Gerri Hobdy*

June 6, 1994

Signature of certifying official/Title Gerri Hobdy, Date  
LA SHPO, Dept of Culture, Recreation and Tourism  
State of Federal agency and bureau

In my opinion, the property  meets  does not meet the National Register criteria. ( See continuation sheet for additional comments.)

Signature of certifying official/Title \_\_\_\_\_ Date \_\_\_\_\_

State or Federal agency and bureau \_\_\_\_\_

4. National Park Service Certification

I hereby certify that the property is:

- entered in the National Register.  
 See continuation sheet.
- determined eligible for the National Register.  
 See continuation sheet.
- determined not eligible for the National Register.
- removed from the National Register.
- other, (explain:)

*Paul R. Frazier*

Signature of the Keeper

Date of Action

9/23/94

Linwood Plantation Manager's House

Name of Property

Tensas Parish, LA

County and State

5. Classification

Ownership of Property

(Check as many boxes as apply)

Category of Property

(Check only one box)

- private
- public-local
- public-State
- public-Federal
- building(s)
- district
- site
- structure
- object

Number of Resources within Property

(Do not include previously listed resources in the count.)

Contributing	Noncontributing	
1		buildings
		sites
		structures
		objects
1	0	Total

Name of related multiple property listing

(Enter "N/A" if property is not part of a multiple property listing.)

N/A

Number of contributing resources previously listed in the National Register

0

6. Function or Use

Historic Functions

(Enter categories from instructions)

DOMESTIC/single dwelling

Current Functions

(Enter categories from instructions)

VACANT/not in use

7. Description

Architectural Classification

(Enter categories from instructions)

Greek Revival

Materials

(Enter categories from instructions)

foundation brick

walls weatherboard

roof metal

other

Narrative Description

(Describe the historic and current condition of the property on one or more continuation sheets.)

**United States Department of the Interior  
National Park Service****National Register of Historic Places  
Continuation Sheet**

Linwood Plantation Manager's House, Newellton vicinity, Tensas Parish, LA

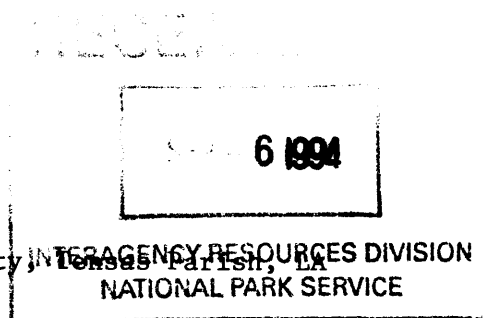
Section number 7 Page 1

The Linwood Plantation Manager's House (c. 1875) is a one story frame late vernacular interpretation of the Greek Revival style. The house stands facing Lake St. Joseph in a rural agricultural area near the Tensas Parish community of Newellton. Although it has experienced some changes over the years, it remains eligible for National Register listing.

The house consists of a post-Civil War main block and a rear connecting ell whose pegged framing indicates it to be much older than the structure to which it is connected. Although the ell's floorplan has been altered (see below), that of the main block remains intact. It consists of five rooms within two ranges. The front range contains a central hall with one room on each side. The shallow rear range contains three rooms, and its middle room is wider than the center hall behind which it is located. Galleries are attached to the front and side of the main block, as well as to the side and rear of the ell.

The home's notable Greek Revival feature is its use of simple pediment-shaped lintels. These are found above most of the windows on the main block and ell, indicating that the latter's exterior was remodeled when the main block was constructed. Pedimented lintels are also found above all of the interior doors within the main block and above two exterior doors. The lintel above the main entrance is larger than the rest, for it surmounts a single leaf door accompanied by a transom and sidelights. While the door and sidelights themselves have been replaced (see below), the original transom survives. Though not specifically a Greek Revival feature, the molded vertical and horizontal wooden members surrounding the transom and sidelights add a mark of distinction to the entrance. Simple entablatures surmount the pillars along the galleries.

Linwood has experienced the following alterations since its construction:

- 1) the replacement of its original front door and sidelights with Eastlake examples which are more elaborate than one would expect to find in a rural area. The glass inserts within the door and sidelights are subdivided in a manner suggestive of the Queen Anne Revival. A door opening onto the main block's side gallery may also have been replaced at this time.

CONTINUED

**United States Department of the Interior  
National Park Service**

**National Register of Historic Places  
Continuation Sheet**

Linwood Plantation Manager's House, Newellton vicinity, Tensas Parish, LA

Section number 7 Page 2

---

- 2) a 1968 rehabilitation which accomplished the following:
  - 1) the remodeling of the ell. One of the rooms within the original two room wing was subdivided to create two baths and a hallway. A closet and vertical beaded board wall covering were added in the second room.
  - 2) the repair of the home's chimneys, the replacement of the home's original foundation with newer brick piers, and the filling of the spaces between the piers with vertical boards.
  - 3) the replacement of the galleries' balustrades with new railings composed of two-by-fours arranged in a geometric pattern and the replacement of the pillars. The pillars currently in place on the main gallery are copies of the originals and have shallow chamfers for decoration. The pillars on the ell's gallery were replaced by two-by-fours.
  - 4) the sheetrocking of the interior walls,
- 3) changes to the ell's facade. One door has been converted into a window and another door's location has been changed. This work was accomplished after the 1968 rehabilitation.
- 4) the loss of the home's simple Greek Revival mantels and the ell's exterior stair.

Although the above mentioned alterations at first glance seem significant, the home still conveys the appearance and feeling of a late vernacular Greek Revival style house. It is this identity for which it is being nominated to the National Register. Houses reflecting architectural styles earlier than the Queen Anne Revival are rare within Tensas Parish, whose building patrimony primarily reflects late nineteenth and early twentieth century styles (see Part 8). As a rare example of the pre-Queen Anne taste and an equally rare example of the Greek Revival within Tensas Parish, the Linwood Plantation Manager's House is a viable candidate for National Register listing.

**8. Statement of Significance**

**Applicable National Register Criteria**

(Mark "x" in one or more boxes for the criteria qualifying the property for National Register listing.)

- A** Property is associated with events that have made a significant contribution to the broad patterns of our history.
- B** Property is associated with the lives of persons significant in our past.
- C** Property embodies the distinctive characteristics of a type, period, or method of construction or represents the work of a master, or possesses high artistic values, or represents a significant and distinguishable entity whose components lack individual distinction.
- D** Property has yielded, or is likely to yield, information important in prehistory or history.

**Criteria Considerations** N/A  
(Mark "x" in all the boxes that apply.)

Property is:

- A** owned by a religious institution or used for religious purposes.
- B** removed from its original location.
- C** a birthplace or grave.
- D** a cemetery.
- E** a reconstructed building, object, or structure.
- F** a commemorative property.
- G** less than 50 years of age or achieved significance within the past 50 years.

**Areas of Significance**

(Enter categories from instructions)

architecture

**Period of Significance**

c. 1875

**Significant Dates**

c. 1875

**Significant Person**

(Complete if Criterion B is marked above)

N/A

**Cultural Affiliation**

N/A

**Architect/Builder**

unknown

**Narrative Statement of Significance**

(Explain the significance of the property on one or more continuation sheets.)

**9. Major Bibliographical References**

**Bibliography**

(Cite the books, articles, and other sources used in preparing this form on one or more continuation sheets.)

**Previous documentation on file (NPS):** N/A

- preliminary determination of individual listing (36 CFR 67) has been requested
- previously listed in the National Register
- previously determined eligible by the National Register
- designated a National Historic Landmark
- recorded by Historic American Buildings Survey # \_\_\_\_\_
- recorded by Historic American Engineering Record # \_\_\_\_\_

**Primary location of additional data:**

- State Historic Preservation Office
- Other State agency
- Federal agency
- Local government
- University
- Other

Name of repository:

\_\_\_\_\_

Linwood Plantation Manager's House  
Name of Property

Tensas Parish, LA  
County and State

## 10. Geographical Data

**Acreeage of Property** @ 1 acre

### UTM References

(Place additional UTM references on a continuation sheet.)

1	1 5	6 7 2 2 0 0	3 5 4 4 8 3 0
Zone	Easting	Northing	
2			

3			
Zone	Easting	Northing	
4			

See continuation sheet

### Verbal Boundary Description

(Describe the boundaries of the property on a continuation sheet.)

See sketch map.

### Boundary Justification

(Explain why the boundaries were selected on a continuation sheet.)

## 11. Form Prepared By

name/title National Register Staff

organization Division of Historic Preservation date April 1994

street & number P. O. Box 44247 telephone (504) 342-8160

city or town Baton Rouge state Louisiana zip code 70804

### Additional Documentation

Submit the following items with the completed form:

#### Continuation Sheets

#### Maps

A **USGS map** (7.5 or 15 minute series) indicating the property's location.

A **Sketch map** for historic districts and properties having large acreage or numerous resources.

#### Photographs

Representative **black and white photographs** of the property.

#### Additional items

(Check with the SHPO or FPO for any additional items)

### Property Owner

(Complete this item at the request of SHPO or FPO.)

name Lucille Jacoby Blum and Margaret Blum Epstein

street & number 7524 St. Charles Avenue telephone (504) 861-8777

city or town New Orleans state Louisiana zip code 70118

**Paperwork Reduction Act Statement:** This information is being collected for applications to the National Register of Historic Places to nominate properties for listing or determine eligibility for listing, to list properties, and to amend existing listings. Response to this request is required to obtain a benefit in accordance with the National Historic Preservation Act, as amended (16 U.S.C. 470 *et seq.*).

**Estimated Burden Statement:** Public reporting burden for this form is estimated to average 18.1 hours per response including time for reviewing instructions, gathering and maintaining data, and completing and reviewing the form. Direct comments regarding this burden estimate or any aspect of this form to the Chief, Administrative Services Division, National Park Service, P.O. Box 37127, Washington, DC 20013-7127; and the Office of Management and Budget, Paperwork Reductions Projects (1024-0018), Washington, DC 20503.

**United States Department of the Interior  
National Park Service**

**National Register of Historic Places  
Continuation Sheet**

Linwood, Tensas Parish, LA

Section number 8 Page 1

---

The Linwood Plantation Manager's House is architecturally significant on the local level as a rare example of the pre-Queen Anne Revival taste within Tensas Parish. Although a simple vernacular interpretation, the house is also one of the few remaining examples of the Greek Revival style in a parish where they must have once been quite numerous.

Tensas Parish is named for an Indian tribe found in the area by the French when Rene Robert Cavalier, the Sieur de La Salle, explored the Mississippi River in 1682 (see Historical Note). Located in the northeast portion of the state, the Tensas region was included within Concordia Parish when the latter was first created in 1805 and reorganized in 1807. However, the area was prone to flood and remained largely unsettled for many years. By the 1840s the Tensas region's population had finally grown large enough to justify the creation of a separate political subdivision, and on March 17, 1843, the northern reaches of Concordia officially became Tensas Parish. The village of St. Joseph was designated as parish seat.

Because the Mississippi's repeated overflows kept the soil's fertility high, the parish developed a successful plantation economy. On the eve of the Civil War, its population was 91% slaves and there were 118 large slaveholdings (i.e., fifty or more slaves). Of these 118, the average size of a slaveholding was 100. The absentee ownership rate was 34%. Hence of the 118 large slaveholdings in the parish, 78 of them involved individuals who resided on the property. Given the above, it is clear that there must have been numerous Greek Revival houses in Tensas Parish on the eve of the Civil War. Twenty of these plantations were located along the shores of the oxbow Lake St. Joseph. These planters were so prosperous that one Union soldier who crossed the region during the 1863 Vicksburg campaign described it as "...the nicest and richest country that I have been in." Linwood was the southernmost plantation on Lake St. Joseph's eastern shore. However, all but one of the Lake St. Joseph houses (Winter Quarters--National Register) were destroyed by the invading forces.

Despite the fact that Tensas Parish was well settled in the antebellum period, little survives from before the late nineteenth century. Tensas has not yet been surveyed, but the staff's knowledge of this rural parish indicates that its architectural patrimony largely consists of late nineteenth and early twentieth century Queen Anne style houses, bungalows, and nondescript cottages and commercial buildings. As far as the State Historic Preservation Office can determine, there are only about a half dozen or so examples of the Greek Revival style in the entire parish. In the opinion of the Louisiana SHPO, all of these rare survivors are eligible for National Register listing. Though a post-Civil War house, the Linwood Manager's House,

CONTINUED

**United States Department of the Interior  
National Park Service**

**National Register of Historic Places  
Continuation Sheet**

Linwood, Tensas Parish, LA

Section number  $\frac{8}{9}$  Page  $\frac{2}{1}$

---

with its vernacular Greek Revival styling, is part of a very small collection of houses representing the parish's earlier architectural taste.

Historical Note

Like the Manager's House, a second Linwood Plantation main house was constructed after the Civil War. Unfortunately, this house was destroyed by fire within the last few years, leaving the Manager's House as the only surviving structure on the property.

Linwood Plantation is believed by some historians to be the site upon which La Salle met the Tensas Indians during his 1682 traversal of the Mississippi River. However, professional archaeologists disagree upon whether or not the evidence discovered to date substantiates this claim. Therefore, it is not possible to nominate the Linwood site for archaeological significance at this time.

Bibliography

Hilburn, Jack, telephone interview, April 29, 1994. Mr. Hilburn is the craftsperson who completed the rehabilitation of the Linwood Plantation Manager's House in 1968.

Lamkin, Marjorie E. "Tensas Parish, 1963." St. Joseph, La.: Tensas Parish Police Jury, October, 1963.

Logan, Marie T. Mississippi-Louisiana Border Country: Revised Edition. Baton Rouge, La.: Claitor's Publishing Division, 1980.

Owens, Jeffrey Alan. "The Burning of Lake St. Joseph." Louisiana History. 32(Fall 1991):393-415.

Site visit by National Register Staff.



**United States Department of the Interior**  
**National Park Service**

# **National Register of Historic Places**

## **Continuation Sheet**

Linwood, Tensas Parish, LA

Section number 10 Page 1

---

### **BOUNDARY DESCRIPTION**

Please see attached sketch map.

### **BOUNDARY JUSTIFICATION**

Boundaries were drawn to encompass the nominated resource and its immediate setting. They do not follow property lines because of extensive rural acreage. Should future research demonstrate that the archaeological sites on the plantation are eligible under Criterion D, the acreage can be adjusted at that time.

# LINWOOD PLANTATION MANAGER'S HOUSE

Newellton vicinity, Tensas Parish, Louisiana

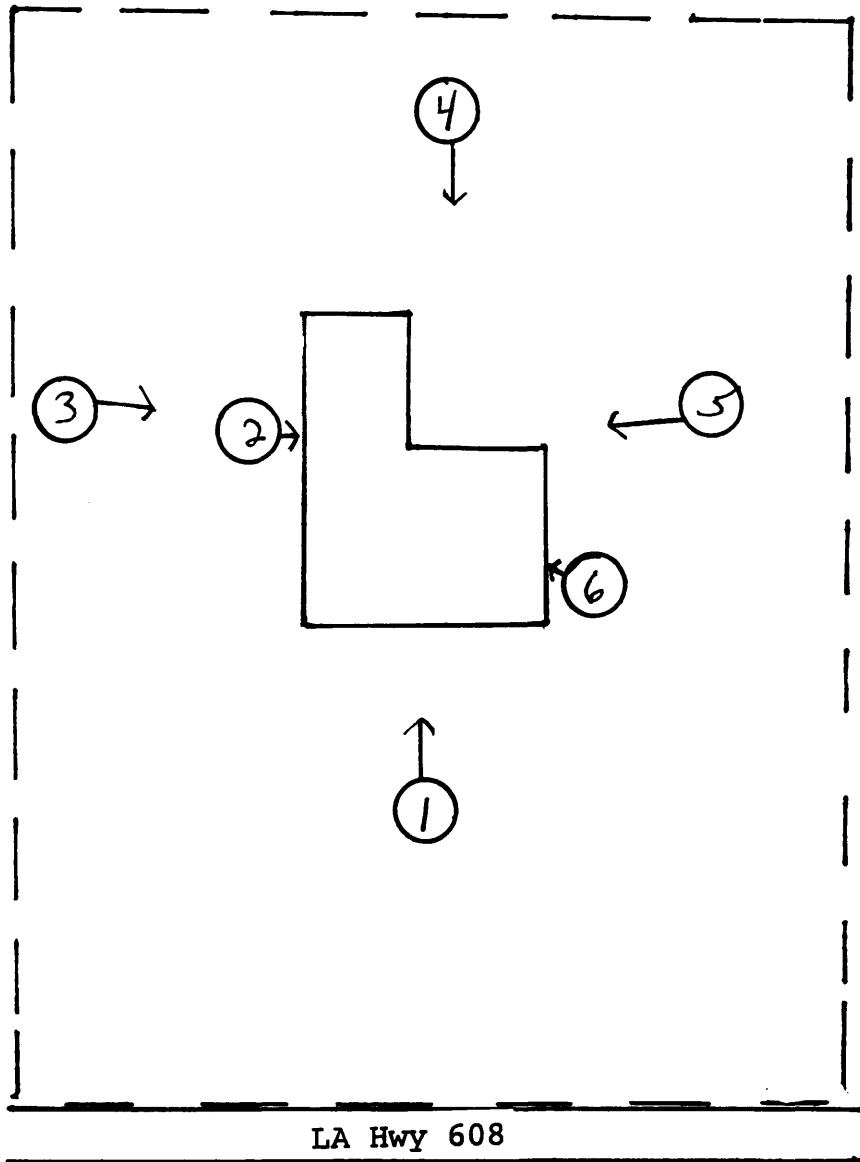

Boundary — — — —

Scale 1" = 40'

North ↑