

562928

United States Department of the Interior
National Park Service

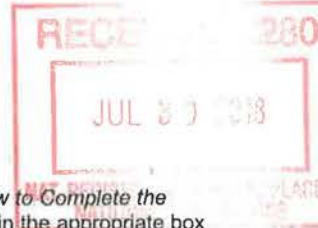

National Register of Historic Places Registration Form

This form is for use in nominating or requesting determinations for individual properties and districts. See instructions in *How to Complete the National Register of Historic Places Registration Form* (National Register Bulletin 16A). Complete each item by marking "x" in the appropriate box or by entering the information requested. If an item does not apply to the property being documented, enter "N/A" for "not applicable." For functions, architectural classification, materials, and areas of significance, enter only categories and subcategories from the instructions. Place additional entries and narrative items on continuation sheets (NPS Form 10-900a). Use a typewriter, word processor, or computer, to complete all items.

1. Name of Property

historic name Minneola Manufacturing Company Cloth Warehouse

other names/site number Minneola Cotton Mill Cloth Warehouse

2. Location

street & number 108 East Railroad Avenue

n/a not for publication

city or town Gibsonville

n/a vicinity

state North Carolina

code NC

county Guilford

code 081

zip code 27249

3. State/Federal Agency Certification

As the designated authority under the National Historic Preservation Act, as amended, I hereby certify that this nomination request for determination of eligibility meets the documentation standards for registering properties in the National Register of Historic Places and meets the procedural and professional requirements set for in 36 CFR Part 60. In my opinion, the property meets does not meet the National Register criteria. I recommend that this property be considered significant nationally statewide locally. (See continuation sheet for additional comments.)

Heidi Chesey
Signature of certifying official/Title

7/23/18
Date

North Carolina Department of Natural and Cultural Resources
State or Federal agency and bureau

In my opinion, the property meets does not meet the National Register criteria. (See Continuation sheet for additional comments.)

Signature of certifying official/Title

Date

State or Federal agency and bureau

4. National Park Service Certification

I hereby certify that the property is:

- entered in the National Register.
 See continuation sheet
- determined eligible for the National Register.
 See continuation sheet
- determined not eligible for the National Register.
- removed from the National Register.
- other, explain: _____

Jan Salter
Signature of the Keeper

Signature of the Keeper

Date of Action

9.11.2018

5. Classification

Ownership of Property
(Check as many boxes as apply)

Category of Property
(Check only one box)

Number of Resources within Property
(Do not include previously listed resources in count.)

- private
- public-local
- public-State
- public-Federal

- building(s)
- district
- site
- structure
- object

Contributing	Noncontributing	
1	0	buildings
0	0	sites
0	0	structures
0	0	objects
1	0	Total

Name of related multiple property listing
(Enter "N/A" if property is not part of a multiple property listing.)

n/a

Number of Contributing resources previously listed in the National Register

n/a

6. Function or Use

Historic Functions
(Enter categories from instructions)

INDUSTRY/industrial storage

Current Functions
(Enter categories from instructions)

COMMERCE/warehouse

7. Description

Architectural Classification
(Enter categories from instructions)

Other: Heavy timber mill construction

Other: Cast-iron-post mill construction

Materials
(Enter categories from instructions)

foundation Brick

walls Brick

roof Synthetic membrane

other _____

Narrative Description

(Describe the historic and current condition of the property on one or more continuation sheets.)

8. Statement of Significance

Applicable National Register Criteria

(Mark "x" in one or more boxes for the criteria qualifying the property for National Register listing.)

- A** Property is associated with events that have made a significant contribution to the broad patterns of our history.
- B** Property is associated with the lives of persons significant in our past.
- C** Property embodies the distinctive characteristics of a type, period, or method of construction or represents the work of a master, or possesses high artistic values, or represents a significant and distinguishable entity whose components lack individual distinction.
- D** Property has yielded, or is likely to yield, information important in prehistory or history.

Criteria Considerations

(Mark "x" in all the boxes that apply.)

Property is:

- A** owned by a religious institution or used for religious purposes.
- B** removed from its original location.
- C** a birthplace or grave.
- D** a cemetery.
- E** a reconstructed building, object, or structure.
- F** a commemorative property
- G** less than 50 years of age or achieved significance within the past 50 years.

Narrative Statement of Significance

(Explain the significance of the property on one or more continuation sheets.)

Areas of Significance

(Enter categories from instructions)

ARCHITECTURE
INDUSTRY

Period of Significance

1907-1968

Significant Dates

1907
1935
1953

Significant Person

(Complete if Criterion B is marked)

n/a

Cultural Affiliation

n/a

Architect/Builder

unknown

9. Major Bibliographical References

Bibliography

(Cite the books, articles, and other sources used in preparing this form on one or more continuation sheets.)

Previous documentation on file (NPS):

- preliminary determination of individual listing (36 CFR 67) has been requested
- previously listed in the National Register
- Previously determined eligible by the National Register
- designated a National Historic Landmark
- recorded by Historic American Buildings Survey # _____
- recorded by Historic American Engineering Record # _____

Primary location of additional data:

- State Historic Preservation Office
- Other State Agency
- Federal Agency
- Local Government
- University
- Other

Name of repository: _____

Minneola Manufacturing Company Cloth Warehouse
Name of Property

Guilford County, North Carolina
County and State

10. Geographical Data

Acreege of Property approximately one acre

UTM References NAD 83

(Place additional UTM references on a continuation sheet.)

1 17 631262.63 3996512.522
Zone Easting Northing

2 _____

3 _____
Zone Easting Northing

4 _____

See continuation sheet

Verbal Boundary Description

(Describe the boundaries of the property on a continuation sheet.)

Boundary Justification

(Explain why the boundaries were selected on a continuation sheet.)

11. Form Prepared By

name/title Jennifer F. Martin
organization MdM Historical Consultants Inc. date March 27, 2018
street & number Post Office Box 1399 telephone 919/368-1602
city or town Durham state NC zip code 27702

Additional Documentation

Submit the following items with the completed form:

Continuation Sheets

Maps

A **USGS map** (7.5 or 15-minute series) indicating the property's location

A **Sketch map** for historic districts and properties having large acreage or numerous resources.

Photographs

Representative **black and white photographs** of the property.

Additional items

(Check with the SHPO or FPO for any additional items.)

Property Owner

(Complete this item at the request of SHPO or FPO.)

name Lindley Industrial Park LLC, attn. Tom Lindley
street & number P.O. Box 2193 telephone 336-584-4156x202
city or town Burlington state NC zip code 27216

Paperwork Reduction Act Statement: This information is being collected for applications to the National Register of Historic Places to nominate properties for listing or determine eligibility for listing, to list properties, and to amend existing listing. Response to this request is required to obtain a benefit in accordance with the National Historic Preservation Act, as amended (16 U.S.C. 470 *et seq.*)

Estimated Burden Statement: Public reporting burden for this form is estimated to average 18.1 hours per response including time for reviewing instructions, gathering and maintaining data, and completing and reviewing the form. Direct comments regarding this burden estimate or any aspect of this form to the Chief, Administrative Services Division, National Park Service, P. O. Box 37127, Washington, DC 20013-7127; and the Office of Management and Budget, Paperwork Reductions Projects (1024-0018), Washington, DC 20303.

United States Department of the Interior
National Park Service

National Register of Historic Places Continuation Sheet

Section number 7 Page 1

Minneola Manufacturing Company Cloth Warehouse
Guilford County, North Carolina

Description

The cloth warehouse at Minneola Manufacturing Company, originally called Minneola Cotton Mill, stands on the east side of the historic mill complex in Gibsonville, Guilford County, North Carolina. The cloth warehouse faces north-northeast and occupies an approximately 1-acre portion of the eighteen-acre rectangular parcel where the Minneola Manufacturing Company has stood since the late-nineteenth century. The cloth warehouse is bounded on the north by East Railroad Avenue, on the east by Smith Street, on the south by Minneola Street, and on the west by the other industrial buildings associated with the Minneola Manufacturing Company. The overall complex is not eligible for the National Register because the entire north wall of the historic mill was covered with brick veneer in the 1980s. The area to the south and east of the cloth warehouse is residential in character. The tracks of the former North Carolina Railroad Company railroad, which arrived in 1854, run north of the warehouse, dividing it from Gibsonville's commercial downtown.

The cloth warehouse is a three-story brick building with a one-story brick addition on its south side. The building was constructed in three phases. The original three-story, rectangular brick warehouse to the north dates to 1907. In 1935, a three-story, brick annex addition on the south of the original block doubled the size of the warehouse. In 1953, the company built a one-story brick packing room and loading dock addition to the south elevation. A small two-story brick addition containing bathrooms was built on the north elevation in 1977.

The cloth warehouse is one building, but it is described in three sections.

Exterior

Cloth Warehouse, 1907, 1977

The original portion of the warehouse is a rectangular building that spans seventeen bays on its north-facing façade and four bays on the east and west elevations. Segmental brick arches and granite sills frame the windows on the three now-visible elevations. In 1935, each window was bricked in, but the brick is

United States Department of the Interior
National Park Service

National Register of Historic Places Continuation Sheet

Section number 7 Page 2

Minneola Manufacturing Company Cloth Warehouse
Guilford County, North Carolina

slightly recessed in the bays so that the window frames are clearly discernable.¹ In the 1950s, a few window bays were fitted with doors or metal louvered vents.

The main entrance is on the west end of the first level of the north elevation and is marked by a modern flat metal canopy. Metal louvered vent panels occupy the first and second level bays immediately to the left or east of the entrance bay. A two-story, flat-roofed, three-bay-wide windowless brick addition containing bathrooms on both levels and dating from 1977 projects from the north elevation. A metal fire escape extending from the third level to the ground is located just to the east or left of the bathroom addition. Tall metal downspouts extend from scuppers at the bottom of the roof parapet, added in 1935, to the ground in front of the building to provide drainage from the roof.

The west elevation is four bays wide. A wide loading dock entrance with a roll-down door added around 1960 is located on the first level at the north end of the elevation. A metal door surrounded by brick fills the southernmost bay on the first level. On the second and third levels either brick or a combination of brick and metal louvered vents fill the window bays. Two bays—the northernmost one on the second level and the one second from the northernmost on the third level—contain wide warehouse-type roll-down doors with flat concrete sills and flat stretcher-bond brick lintels.

The south elevation is covered by the 1935 addition, but its window bays are visible on the interior of the 1907 warehouse. The east elevation, also four bays wide, contains no doors. The windows are bricked in or filled with a combination of brick and metal louvered vents or entire panels of louvered vents. The second and third level window bays retain their rusticated granite sills, while the first level sills have been removed.

The slightly-pitched gable roof is topped with a membrane surface and edged by a brick parapet wall with granite coping. Originally, the membrane roof was covered with gravel.

¹ The plans for the 1935 addition include the note, "windows in old building to be removed and openings bricked up. All 3 floors. Windows in rear of old building 1st floor shall be bricked up also." Minneola Manufacturing Company, First Floor Plan, Sheet 2, 1935, in possession of the property owner.

United States Department of the Interior
National Park Service

National Register of Historic Places Continuation Sheet

Section number 7 Page 3

Minneola Manufacturing Company Cloth Warehouse
Guilford County, North Carolina

Cloth Warehouse Annex, 1935

The three-story, brick building is seventeen bays wide on its south elevation and four bays deep on its west and east elevations. Separating each bay, full-height brick pilasters extend from the ground to the parapet. The building has a flat roof. Rectangular steel windows throughout are fitted with wire glass and framed by concrete sills and soldier course brick lintels.

The west elevation retains intact steel frame windows with center hoppers in the elevator tower that rises above the building's roofline. One other steel window on this elevation with eight-over-sixteen lites remains intact, while the other windows have been partially fitted or completely replaced with louvered metal vents. The altered windows display various lite patterns, including eight intact lites on top or twelve lites or sixteen lites on the bottom.

The east elevation has a single-leaf metal door beneath a flat metal awning on the south end of the first level, but no other openings on that level. The second level includes one intact steel twelve-over-twelve window in the second bay (looking south to north), two northernmost bays filled with metal louvered vents, and the southernmost bay filled with brick and a metal louvered vent. The third level features two intact eight-over-twelve steel windows in the first and third bays (looking south to north) and two steel windows fitted with corrugated metal, but retaining the upper eight lites.

The south elevation of the 1935 annex features seventeen intact twelve-over-twelve windows on the second floor and seventeen intact eight-over-twelve steel windows on the third level. The 1953 addition obscures the first floor where the windows have been infilled with concrete block. The window bays remain discernable on the interior of the 1935 warehouse.

The flat roof is topped with a membrane surface and edged by a brick parapet wall with concrete coping that has been covered with metal. The flat-roofed brick elevator tower on the west elevation extends approximately ten feet above the roof surface. A wood hatch is located on its east elevation and its north and south parapets are topped with metal.

United States Department of the Interior
National Park Service

National Register of Historic Places Continuation Sheet

Section number 7 Page 4

Minneola Manufacturing Company Cloth Warehouse
Guilford County, North Carolina

Packing Room Addition, 1953

A one-story, brick addition with a slightly sloped shed roof extends along the south side of the 1935 annex. The 1953 section has a single metal louvered vent centered on its west elevation. The north end of the east elevation has one single-leaf metal door topped by a flat metal awning and fronted by a metal stair descending south. The south elevation includes twelve original steel windows to the east of the loading dock. A metal canopy at the loading dock shelters three brick-infilled windows at the east end, a large warehouse opening covered by a metal roll-down door, and a single-leaf metal door inserted into a partially brick-infilled former window bay. A metal louvered vent is on the west end of the elevation.

Interior

1907 Cloth Warehouse Interior

The interior originally consisted of open warehouse spaces on each of the three levels. The only major alteration to that configuration is that the first level contains a wide entry corridor created when a north-south-running concrete block wall was built to the east of the entrance in the space in the early 1990s. The wall enclosed only a portion of the large open space that characterized this level of the warehouse. Unlike the rest of the building where the floor is original wood, the floor in the entry corridor is poured concrete. The first level of the 1907 cloth warehouse is built with eighteen steel H-beams and steel joists that run in an east-west direction and support a wooden ceiling. The entry corridor contains an enclosed stair on the west side. A single metal door and a larger warehouse door pierce the concrete block wall on the east side of the concrete block corridor wall and allow entry into the large warehouse space that occupies the remainder of this level.

The second level of the 1907 building features eighteen pine columns running in an east-west direction down the center of the large open space. Iron caps top each column supporting wood ceiling joists. The floor is wood and walls are brick. Window bays have been infilled with brick. A door on the east end of the north wall leads to the fire escape. The stair on the west end has been framed and sheetrocked.

The third level of the 1907 building is nearly identical to the second floor and features eighteen pine columns running in an east-west direction down the center of the large open space. Iron caps top each

United States Department of the Interior
National Park Service

National Register of Historic Places Continuation Sheet

Section number 7 Page 5

Minneola Manufacturing Company Cloth Warehouse
Guilford County, North Carolina

column supporting the center of the ceiling where the wood ceiling joists meet and support the wood deck ceiling. The floor is wood and walls are brick. The windows on the south wall are infilled with brick, while the windows on the north, west, and east walls are infilled with concrete block. Access to the 1935 annex is through a sliding kalamein door—a wood door sheathed in metal—measuring six feet wide by seven feet tall near the east end of the south wall. The door runs on a steel track and is pulled by a rope with a metal weight at the end. Kalamein doors like this one could be closed automatically to help prevent fires from spreading through the warehouse. A metal single-leaf door leading to the fire escape partially fills a bricked-in window near the east end of the north wall. The stair at the west end has been enclosed with sheetrock.

1935 Cloth Warehouse Annex Interior

The interior of the 1935 annex is entered through a wide opening on the west end of the south wall located in the first level corridor of the 1907 building. The corridor, created in the early 1990s when the concrete block wall was built, continues into the 1935 annex. Just inside the entrance to the annex to the west, a brick shaft holds the original elevator. To the south of the elevator is a small enclosed office with a door on its south wall. The floors in the annex's corridor are wood and metal grate. Like the 1907 building, the annex features a warehouse door and single-leaf metal door on the east concrete block wall. These doors lead to a large storage space to the east with wood floors and brick walls. Eighteen steel H-beams support horizontal steel I-beams upon which the wood ceiling rests. Window bays on the south wall have been infilled with concrete block. Brick pilasters along the former south exterior of the 1907 building extend along the north wall. On the north wall, a kalamein door leads to the 1907 building.

The second level features vertical steel H-beams running in a north-south direction down the center of a large open space. The beams support horizontal steel I-beams upon which the wood ceiling rests. A small office with wood walls and two six-lite fixed windows is located on the east wall of the space. The brick elevator enclosure is just to the north or right of the office. An adjacent wide opening located on the west end of the north wall leads to the second floor of the 1907 building. The annex's second floor contains original climate and humidity monitoring equipment, fans, and an original sprinkler system. Bays on the north wall are filled with brick, but others contain original steel windows with center hoppers. A kalamein door measuring six feet wide by seven feet tall is located on the east end of the north wall and leads into the 1907 building.

United States Department of the Interior
National Park Service

National Register of Historic Places Continuation Sheet

Section number 7 Page 6

Minneola Manufacturing Company Cloth Warehouse
Guilford County, North Carolina

The third level is like the second level and features vertical steel H-beams running in a north-south direction down the center of a large open space. The beams support horizontal steel I-beams upon which the wood ceiling rests. The brick elevator enclosure is in the northwest corner and adjacent to the wide opening that leads to the third floor of the 1907 building. Steel H-beams line the north wall. A window on the east elevation is covered with plywood, but the remaining windows are intact. A wide opening on the east end of the north wall leads to the third level of the 1907 building.

1953 Packing Room Addition Interior

Like the 1907 and 1935 sections of the building, the 1953 addition contains a north-south running concrete block wall that divides the larger storage space from a west side corridor. A loading dock door and a single leaf door in the concrete block wall lead to the larger warehouse space. This space contains one large storage space with brick and concrete block walls and a wood floor. Eighteen steel H-beams and steel joists that run in an east-west direction support a wooden ceiling. A kalamein door on the north wall leads to the 1935 annex. On the south wall, all window bays have been bricked in, but the twelve easternmost windows retain their metal sash on the exterior.

Integrity Statement

The cloth warehouse at Minneola Manufacturing Company retains integrity to convey its significance in the area of industry as an essential facility for safeguarding Minneola's valuable finished cloth product and preparing it to ship to market. The cloth warehouse also retains integrity to convey its significance in the area of architecture as an important textile-related building type in piedmont North Carolina. Like other historic textile buildings in the region, the cloth warehouse expanded over time to meet production and storage demands and to respond to changing technology. The cloth warehouse retains its integrity of location because it remains in the place where it was built and later expanded. The cloth warehouse retains its integrity of setting because it stands in Gibsonville in piedmont North Carolina where it was built and oriented to both the railroad right-of-way and the rest of the Minneola Manufacturing Company complex. Its integrity of design remains intact because its massing, scale, materials, fenestration patterns, structural systems, and overall spatial organization are preserved. The building's character-defining materials including its brick exterior, brick pilasters, granite window sills, steel windows and beams, pine columns,

United States Department of the Interior
National Park Service

National Register of Historic Places Continuation Sheet

Section number 7 Page 7

Minneola Manufacturing Company Cloth Warehouse
Guilford County, North Carolina

and wood floors contribute to the building's integrity of materials. The cloth warehouse's integrity of workmanship is evidenced by the building's brick exterior and heavy timber and cast-iron-post mill construction. The cloth warehouse retains physical features, including a brick exterior, heavy timber and cast-iron-post mill construction, steel windows, wood floors, brick interior walls, and light-filled interior spaces, that contribute to its integrity of feeling. Because the cloth warehouse's physical features survive and because the building functioned as a cloth warehouse for Minneola Manufacturing Company, it possesses integrity of association.

United States Department of the Interior
National Park Service

National Register of Historic Places Continuation Sheet

Section number 8 Page 8

Minneola Manufacturing Company Cloth Warehouse
Guilford County, North Carolina

Summary

The Minneola Manufacturing Company cloth warehouse is eligible for listing in the National Register of Historic Places at the local level under Criterion A for its significance in the area of industry. Minneola Manufacturing Company, of which the cloth warehouse was an integral part, served as the dominant industry in Gibsonville from 1886, when it was founded as Minneola Cotton Mill, until it closed in 1988. It had a major impact on the town's growth and development and formed the basis for Gibsonville's industrial economy for one hundred years. As the primary repository of the finished goods for the Minneola Manufacturing Company, the cloth warehouse functioned as a critical facility for protecting the company's valuable finished cloth product and preparing it to ship to market.

The Minneola Manufacturing Company cloth warehouse is also eligible for listing in the National Register of Historic Places at the local level under Criterion C for its architectural significance. The intact free-standing cloth warehouse illustrates principles in mill design that promoted fire resistance and that protected the finished cloth from the mechanization environment of the main mill building. While cloth warehouses or cloth rooms, as they are sometimes known, were a ubiquitous feature of cotton mill complexes in the early to mid-twentieth century, the Minneola Manufacturing Company cloth warehouse is the largest, still free-standing example in piedmont North Carolina. Its architectural significance stems from the cloth warehouse's embodiment of industrial design and mill construction from the first half of the twentieth century. The three-story brick warehouse, which retains many original steel wire-glass windows and interior steel and pine columns and supports, was built following slow-burn construction techniques as part of the Minneola Manufacturing Company complex.

The period of significance begins at the date of construction, 1907, and ends in 1968. Although the mill operated until 1988, the post-1968 industrial use lacks the exceptional significance necessary to extend the period of significance to within the last fifty years.

Historical Background and Industry Context

The Minneola Manufacturing Company cloth warehouse is eligible for listing in the National Register of Historic Places at the local level under Criterion A for its significance in the area of industry. The Minneola Manufacturing Company cloth warehouse is located in the small town of Gibsonville, which straddles the

United States Department of the Interior
National Park Service

National Register of Historic Places Continuation Sheet

Section number 8 Page 9

Minneola Manufacturing Company Cloth Warehouse
Guilford County, North Carolina

border between Guilford and Alamance counties. Between 1776 and 1790, Andrew Gibson (1750-1824), who was born in Scotland, settled in Guilford County.² One of his sons, Joseph Gibson (1785-1857), owned hundreds of acres in Guilford County, much of it inherited from his father. When Joseph Gibson learned the North Carolina Railroad planned to run its tracks near his land, he offered to grade the rail bed if the company would establish the line on his property. Gibson's slaves began laying the rail line in 1851 and a depot was built in 1854. The North Carolina Railroad named the area around the depot Gibsonville, in honor of Joseph Gibson. Gibsonville was incorporated on February 18, 1871 with the depot at the center of the town's one-square-mile boundary.³

According to the 1979 architectural resource inventory for Gibsonville, High Point, and Jamestown published by the North Carolina Department of Cultural Resources, "Gibsonville is representative of a late nineteenth century mill town, in which the town functions as an independent municipality, but is dominated physically and economically by the factory, in this case the Minneola Cotton Mill."⁴ The textile industry, which played a major role in the growth and development of Gibsonville, began in Guilford County when merchant Henry Humphreys established Mt. Helca Steam Cotton Mill in Greensboro in 1833. The first steam cotton mill in the state and one of the earliest in the South, the machinery for Mt. Helca came from Philadelphia and was shipped upriver from Fayetteville.⁵

Minneola Manufacturing Company was the first major industry in Gibsonville and served as the dominant industry in Gibsonville from 1886, when it was founded as Minneola Cotton Mill, until it closed in 1988. Berry Davidson (1831-1913), a prominent millwright and prolific mill builder during the last half of the nineteenth century, and his nephew, Joseph A. Davidson, established Minneola Cotton Mill in 1886. The Davidsons began Minneola in a single steam-powered building containing twenty-eight looms on which

² Andrew Gibson arrived in North Carolina in 1776 according to Donald Whyte, *A Dictionary of Scottish Emigrants to the USA, Volume 1* (Baltimore: Magna Carta Book Co., 1972), 132; Andrew Gibson first appears in the census for Guilford County in 1790, 1790 United States Federal Census, Guilford County, Ancestry.com, accessed March 23, 2018; "Andrew D. Gibson," U.S. Find a Grave Index, Ancestry.com, accessed March 23, 2018.

³ "Gibsonville Belongs to Alamance, Guilford Counties," *The Daily Times-News* (Burlington), May 23, 1976.

⁴ H. McKelden Smith, ed., *Architectural Resources: An Inventory of Historic Architecture, High Point, Jamestown, Gibsonville, Guilford County* (Raleigh: North Carolina Department of Cultural Resources, Division of Archives and History, 1979; reprint [by same], 1980, 21.

⁵ On November 26, 1833, the *Fayetteville Weekly Observer*, quoting the *Greensborough Patriot* newspaper, reported that "Mr. Henry Humphreys has completed the buildings for his Cotton Factory in that town."; *Greensboro Daily News*, February 15, 1914; "First Cotton Mill Built in the South Built in N.C.," *Western Sentinel* (Winston-Salem), August 18, 1922.

United States Department of the Interior
National Park Service

National Register of Historic Places Continuation Sheet

Section number 8 Page 10

Minneola Manufacturing Company Cloth Warehouse
Guilford County, North Carolina

they produced plaids.⁶ Two years later, in 1888, the Davidsons, Charles H. Fisher, and John W. Page incorporated the company as the Minneola Manufacturing Company. By this time, the mill processed cotton into fabrics, thread, and cloth and employed forty operatives.⁷

Cone Export and Commission Company, headed by brothers Moses and Caesar Cone of Baltimore, purchased Berry Davidson's interest in Minneola Manufacturing Company in 1892. Davidson left the company and opened Hiawatha Mill, also in Gibsonville.⁸ Five years later, in 1898, Minneola Manufacturing Company had 150 workers, almost four times the number it had ten years earlier.⁹ By this time, Gibsonville's population stood around five hundred. In addition to the town's two largest employers, Minneola Manufacturing Company and Hiawatha Mills, other industries included W. C. Michael's woodworking business, Huff's flour mill, a cannery, and a tannery.¹⁰ In the fall of 1899, a Greensboro newspaper reported that Gibsonville boasted seven general stores, a drug store, a hotel, a livery barn, and some minor enterprises." The article added that "three nice churches and a good school are to be found there."¹¹

The mill continued to expand in the late nineteenth and early twentieth centuries so that by 1901, Minneola Manufacturing Company operated 200 looms and 2,000 spindles to make plaids and sheetings.¹² In 1903-1904, J. W. Cone was president and Joseph A. Davidson, an original founder, served as secretary and treasurer. In January 1903, the company announced it would expand from 200 looms to 500 looms and the main building of the plant was to be doubled in size to accommodate the weaving department. A finishing room and a new spinning mill with a capacity of ten thousand spindles was planned.¹³ In announcing the expansion, *the Greensboro Patriot* newspaper noted that the "thriving village of Gibsonville in eastern

⁶ "Minneola Manufacturing Company, Gibsonville, N.C.," *The Raleigh Times*, April 22, 1907; Catherine W. Bishir, "Berry Davidson (1831-1915)," *North Carolina Architects and Builders: A Biographical Dictionary*, Copyright & Digital Scholarship Center, North Carolina State University Libraries, Raleigh, NC.

⁷ "Notice of Incorporation," *Greensboro Daily Workman*, September 1, 1888; "New State Enterprises," *The Reidsville Review*, June 26, 1889.

⁸ W. Clark Lindley, e-mail communication with Richard Angino, August 23, 2013; Bishir, "Berry Davidson (1831-1915).

⁹ "Gibsonville," *The Greensboro Patriot*, April 20, 1898.

¹⁰ "Gibsonville: Eastern Guilford's Busiest Town," *The Greensboro Patriot*, May 3, 1899.

¹¹ "Gibsonville's Progress," *The Greensboro Patriot*, September 20, 1899.

¹² "A Busy, Happy, Town," *The North Carolinian* (Raleigh), November 14, 1901.

¹³ "Minneola Mill to be Enlarged," *The Wilmington Messenger*, January 30, 1903. A worker village immediately south of the mill no longer exists.

United States Department of the Interior
National Park Service

National Register of Historic Places Continuation Sheet

Section number 8 Page 11

Minneola Manufacturing Company Cloth Warehouse
Guilford County, North Carolina

Guilford, will take on new life this year which augurs well not only for the fine farming country round about, but for the grand old county of which it is a component part and the state at large."¹⁴

In 1907, the year the cloth warehouse was built, the plant was making plain and twilled flannel for the production of linens and clothing at its seven-acre site. Four hundred employees worked the twelve looms and 15,000 spindles.¹⁵ As production increased, the need for a free-standing building where finished products could be stored safely before shipping became critical. Originally planned as a two-story building, the company decided on a three-story building with ample space to accommodate the output from the plant.¹⁶

As the repository of the company's finished cloth, the Minneola Manufacturing Company cloth warehouse was seen as a vital part of the dominant industry in Gibsonville. Its importance is highlighted by correspondence between the mill and Factory Insurance Association of Hartford, Connecticut, which insured Minneola Manufacturing Company in the early twentieth century and monitored the cloth warehouse while it was under construction. In a telegram dated May 14, 1907, the insurance company directed the cotton mill to "take extraordinary precaution while sprinkler [in the] warehouse is being connected. Maintain continuous watchman service. Wire immediately [when] protection restored."¹⁷ Factory Insurance Association followed up in a letter in October of that year that the mill must "provide 18 pails in each of the three floors," referring to the buckets of water they required in case a fire needed to be extinguished.¹⁸

In addition to providing construction guidelines for the types of buildings they insured, Factory Insurance Association also required Cone Mills to report on the type and quantities of materials stored in the buildings at Minneola and the amount of coverage the building and its contents required. The cotton mill

¹⁴ "Guilford County's Textile Interest Expanding," *The Greensboro Patriot*, January 28, 1903.

¹⁵ "Minneola Manufacturing Company, Gibsonville, N. C.," *The Raleigh Times*, April 22, 1907; the population in 1907 is unknown, but the 1910 population stood at 1,162.

¹⁶ Sketch of cloth warehouse dated February 5, 1907, Factory Insurance Association records: 1906-1922, in the Cone Mills Records, Southern Historical Collection, UNC-Chapel Hill.

¹⁷ Telegram from Factory Insurance Association to Minneola Manufacturing Company, May 14, 1907, Factory Insurance Association records: 1906-1922, in the Cone Mills Records, Southern Historical Collection, UNC-Chapel Hill.

¹⁸ Letter from G. Y. Lancaster, Inspector, to Minneola Manufacturing Company, November 3, 1907, Factory Insurance Association records: 1906-1922, in the Cone Mills Records, Southern Historical Collection, UNC-Chapel Hill.

United States Department of the Interior
National Park Service

National Register of Historic Places Continuation Sheet

Section number 8 Page 12

Minneola Manufacturing Company Cloth Warehouse
Guilford County, North Carolina

recorded that the cloth warehouse contained 35,000 pieces of cloth on December 1, 1911.¹⁹ Minneola also reported to the insurance company the packing material, containers, and nails stored in the cloth warehouse used to package the cloth for shipping. On June 12, 1916, Minneola described that the cloth warehouse contained among other materials, twenty barrels of hemp twine, several hundred plank (wood) or veneer boxes, seventy-four kegs of nails, and forty-five bundles of blue paper.²⁰

The cloth warehouse typically held finished goods, while the mill's five warehouses, which are located to the southwest of the cloth warehouse, held raw cotton exclusively. These warehouses are one-story, rectangular brick buildings with flat roofs and firewalls between them to prevent the spread of fire. In September 1917, warehouses one through three contained over twelve hundred bales of cotton. At the same time the company stored paper, spools, nails, cloth, brooms, twine, jars, chemicals, and slab leather in the cloth warehouse.²¹ The importance of the cloth warehouse and its contents is evidenced by the fact that Minneola Manufacturing Company insured it alone for \$30,000.²²

In late 1918 and early 1919, Minneola employed 300 workers operating 616 looms and 18,684 spindles. The town grew alongside the mill so that by 1920, 1,302 people lived in Gibsonville.²³ The Gibsonville plant included facilities for dyeing and finishing and had three boilers.²⁴ In the early twentieth century, the Cones constructed a mill village immediately south of the plant to house its workers.²⁵ In 1935, as production increased, Minneola Manufacturing Company built an annex to the south side of the cloth warehouse that doubled its size.

¹⁹ "Cloth in Storage Warehouse," Factory Insurance Association records: 1906-1922, in the Cone Mills Records, Southern Historical Collection, UNC-Chapel Hill.

²⁰ "June 12, 1916: Contents Warehouses, Opening Room, Storage Building," Factory Insurance Association records: 1906-1922, in the Cone Mills Records, Southern Historical Collection, UNC-Chapel Hill.

²¹ "September 18, 1917: Contents Warehouses, Opening Room, Storage Building," Factory Insurance Association records: 1906-1922, in the Cone Mills Records, Southern Historical Collection, UNC-Chapel Hill.

²² Letter from Factory Insurance Association to Minneola Manufacturing Company, December 15, 1917, Factory Insurance Association records: 1906-1922, in the Cone Mills Records, Southern Historical Collection, UNC-Chapel Hill.

²³ "Minneola Mill Employees Make Fine Record in Backing Up Government," *The Charlotte Observer*, November 24, 1918. Melvyn O. Wyrick, "History of the Town of Gibsonville," 1971, www.gibsonville.net, accessed March 22, 2018.

²⁴ *America's Textile Reporter: For the Combined Textile Industries*, Volume 33, Issue 10, 1919.

²⁵ The mill houses have been moved or destroyed and the only evidence of the village are the streets it occupied.

United States Department of the Interior
National Park Service

National Register of Historic Places Continuation Sheet

Section number 8 Page 13

Minneola Manufacturing Company Cloth Warehouse
Guilford County, North Carolina

In 1940, Gibsonville's population stood at 1,753.²⁶ Many of the plant's workers saw action in World War II and unfortunately many lost their lives. In the summer of 1945, Thomas Hinton, who worked at Minneola Manufacturing Company before serving in the war, died off Okinawa after a Japanese suicide plane dropped a bomb on the destroyer *Abele*.²⁷

The textile industry, including all of Cone Mills' facilities, prospered during the post-World War II era. By the 1940s, the Cone company was purchasing over a million dollars' worth of raw material and converting it to finished cotton flannels. About eighty-five percent of this material was shipped out of North Carolina.²⁸ In 1949, Minneola Manufacturing Company employed 750 workers. Around this time, Minneola Manufacturing Company started making denim.²⁹

By 1950, the population of Gibsonville had climbed to 1,866.³⁰ Minneola remained the largest textile plant in Gibsonville. Other industries included Gibsonville Hosiery Mills and Dixie Bell Textiles, two small operations compared to Minneola, and Engineered Plastics Inc., which made plastics for textile plants. The town included two African American and five white churches and numerous retail concerns.³¹

In 1953, a one-story brick addition containing a packing house and loading dock was built onto the rear of the cloth warehouse. Around the same time, the winder room and dye waste facility in the main plant received additions. The company also sold many of its mill houses to employees that year. By the mid-1950s, the plant employed 600 people and made denim and flannel shirting.³² In 1957, Minneola was making greige goods, fabric in its raw and un-dyed or un-printed state, instead of denim. The mill employed 460 people and produced 11 million yards of greige goods during 1957.³³ By the early 1960s, the plant had converted to producing sateens and twills with 417 workers.³⁴

²⁶ Melvyn O. Wyrick, "History of the Town of Gibsonville," 1971, www.gibsonville.net, accessed March 22, 2018.

²⁷ "Gibsonville News," *The Daily Times-News* (Burlington), July 14, 1945.

²⁸ *In the Matter of Minneola Manufacturing Company and Textile Workers Union of America* (C. I. O.), Case No. 5-R-1651, September 16, 1944, National Labor Relations Board, www.nlr.gov, accessed April 26, 2016.

²⁹ *The Daily Times-News* (Burlington), January 28, 1957; *The Daily Times-News* (Burlington), May 9, 1949.

³⁰ Melvyn O. Wyrick, "History of the Town of Gibsonville," 1971, www.gibsonville.net, accessed March 22, 2018.

³¹ "Modern Progress Review of the County, Gibsonville," *The Daily Times-News* (Burlington), May 9, 1949.

³² "Gibsonville Has Normal Progress During Year," *The Daily Times-News* (Burlington), January 30, 1954.

³³ "Cone Mills Shows Steady Progress," *The Daily Times-News* (Burlington), January 27, 1958.

³⁴ "Cone Mills Reports Good Year," *The Daily Times-News* (Burlington), February 4, 1963.

United States Department of the Interior
National Park Service

National Register of Historic Places Continuation Sheet

Section number 8 Page 14

Minneola Manufacturing Company Cloth Warehouse
Guilford County, North Carolina

In October 1988, the Cone Mills Corporation announced the closing of the Minneola Manufacturing Company, which employed 500 workers. The company blamed competition from imported fabric, unfavorable business conditions, and the need to consolidate its operations.³⁵

In 1988, Lindley Industrial Park LLC, owned by the Lindley family of Burlington, purchased the mill and currently rents a portion of it for a variety of uses. The cloth warehouse is mostly empty except for a few businesses that lease space.

The Minneola Manufacturing Company cloth warehouse is eligible for listing in the National Register of Historic Places at the local level under Criterion A for its significance in the area of industry. The cloth warehouse was an integral part of Minneola Manufacturing Company, which was as the chief industry in Gibsonville from 1886, when it was founded as Minneola Cotton Mill, until it closed in 1988. The company heavily impacted the town's growth and development and formed the basis for the town's economy for one hundred years. As the main repository of the finished cloth for the Minneola Manufacturing Company, the three-story, brick warehouse was an essential facility for safeguarding the company's product and preparing it for shipment to market.

Architecture Context

The Minneola Manufacturing Company Cloth Warehouse is eligible for the National Register of Historic Places under Criterion C for architecture as a locally significant example of early twentieth century textile mill construction in Gibsonville and of a free-standing cloth warehouse in piedmont North Carolina. The location, form, materials, and features of the cloth warehouse exemplify early twentieth-century free-standing cloth warehouse construction in piedmont North Carolina and demonstrate the crucial role of cloth warehouses in providing a controlled and safe environment for storing the valuable finished products for a textile manufacturing facility. The construction standards and design at the cloth warehouse conformed to standards of insurance requirements that called for what was known as slow-burn construction where wood timbers and steel H-beams maintained structural integrity in case of fire. Builders erected early twentieth-century industrial buildings like the cloth warehouse with structural steel construction made of standard factory-made parts. I-shaped columns and beams with reinforced plates and joints could be riveted together to create substantial support that allowed for larger buildings with expansive open interior space. Other

³⁵ *The Dispatch* (Lexington), October 31, 1988.

United States Department of the Interior
National Park Service

National Register of Historic Places Continuation Sheet

Section number 8 Page 15

Minneola Manufacturing Company Cloth Warehouse
Guilford County, North Carolina

features such as kalamein doors—wood doors covered with plates of sheet metal—contributed to the warehouse’s fireproof qualities by preventing the spread of fire.³⁶

As insurance companies promoted fire-resistive construction, widely disseminated publications from the late nineteenth century including C. J. H. Woodbury’s *The Fire Protection of Mills* from 1882 and Frank Kidder’s *Architects and Builders Pocketbook* from 1885 helped to influence the construction of textile buildings. Mill engineers trained in the northeast, where the textile industry proliferated, also spread the tenets of slow-burn mill design and construction across the country, including in North Carolina.³⁷ Following fireproof standards of the period, textile mill buildings throughout piedmont North Carolina were usually brick, stood at least two stories tall, had flat or slightly-pitched gable roofs, oversized windows, and heavy interior timbers. Wood used in industrial buildings was combustible, but it did not warp, expand, or falter when it was first subjected to heat. Safety standards included brick fire walls, fire pumps, sprinklers, and of course, buckets.

The plan and placement of the cloth warehouse reflect a deliberateness on the part of the company to construct a building that would assure the preservation of its finished products and provide for ease in shipping. In erecting a commodious free-standing building devoted to cloth storage, the company protected the flannels it was making by storing them away from the processing portions of its plant. The cloth warehouse was humidity-controlled, unlike the production areas where humidity was kept high to prevent thread from breaking. The conditions in the cloth warehouse, which was free from the cotton dust swirling around the main mill, assured that the cloth would be in the best condition for shipping. The placement of the building away from the mill meant that a fire in the mill, especially in the opening and picking rooms where fires were most common, would not reach the finished cloth. Cloth warehouses like the one at Minneola Manufacturing Company were nearly always located near the railroad siding to provide ease of loading onto rail cars. As plants transitioned to trucks for transporting goods, loading docks, like the one added to the cloth warehouse in 1953, became essential.

Factory Insurance Association of Hartford, Connecticut insured Minneola Manufacturing Company in the early twentieth century and provided guidance for constructing buildings that could withstand total

³⁶ C. T. Richards, "Kalamein Work and the Making of a Metal Covered Door." *The Metal Worker, Plumber, and Steam Fitter*, December 5, 1908, 40.

³⁷ Betsy Hunter Bradley, *The Works: Industrial Architecture of the United States* (New York: Oxford University Press, 1999), 129.

United States Department of the Interior
National Park Service

National Register of Historic Places Continuation Sheet

Section number 8 Page 16

Minneola Manufacturing Company Cloth Warehouse
Guilford County, North Carolina

devastation from fire, including the cloth warehouse for the Gibsonville plant. An undated sheet of instructions from the insurance company in the Cone Mills Records entitled "General Specifications for Storehouses, Two or More Stories in Height," directed that the cloth warehouse be located at least fifty feet from any other building, most likely to prevent the spread of fire, and that the outside walls be constructed of brick or reinforced concrete at least twelve inches thick. Window openings were to be as few as possible and fitted with wire glass in metal frames, such as those in the 1935 annex. The insurance company also directed that sprinklers be installed throughout and that smoking "be absolutely prohibited."³⁸

Insurers like Factory Insurance Association directed many aspects of a mill building's construction including doors, especially interior doors, which proved crucial to stopping the spread of fire. Kalamein doors are common throughout mill buildings, including the cloth warehouse at Minneola Manufacturing Company. They were generally built of two or three thicknesses of tongue and groove boards that were then nailed together diagonally. The door was then covered in tin or sheet metal that was nailed on so that the nail heads were not exposed. The door hung on special rollers and an overhead track so that it would close when not held open. A cord held the door open, but if a fire occurred, that cord would burn and break causing the door to close thus shutting off one section of the building from the adjacent section.³⁹

Only two other industrial complexes survive in Gibsonville. In the 1890s, Berry Davidson, founder of Minneola Manufacturing Company, founded Hiawatha Cotton Mill, on Eugene Street. The oldest section, a two-story, brick carding and spinning room has segmental arch windows and a low-gabled roof. Throughout the twentieth century, extensive one-story brick additions surrounded the original core, which is now only partially visible from the rear of the complex, so that the mill has the appearance of a mid- to late-twentieth century industrial complex. The east end of the Eugene Street elevation has an art moderne façade with projecting bands of brick and curved walls leading to a double-leaf fully-glazed entrance. Hiawatha Cotton Mill lacks a free-standing cloth warehouse.

Gibsonville Hosiery Mill is on the north side of Burlington Street between Chase Street and Apple Street in northeast Gibsonville and is just over the border in Alamance County. The large complex of one-story buildings began around 1914 with the one-story, low-pitched-gabled-roofed brick building at the southwest

³⁸ Factory Insurance Association, "General Specifications for Storehouses, Two or More Stories in Height," Factory Insurance Association records: 1906-1922, in the Cone Mills Records, Southern Historical Collection, UNC-Chapel Hill.

³⁹ Daniel August Tompkins, *Cotton Mill, Commercial Features. A Text Book for the Use of Textile Schools and Investors* (Charlotte, North Carolina: By the author, 1899), 166.

United States Department of the Interior
National Park Service

National Register of Historic Places Continuation Sheet

Section number 8 Page 17

Minneola Manufacturing Company Cloth Warehouse
Guilford County, North Carolina

corner. It features a south end parapet wall and segmental-arched windows with brick infill. The mill was expanded in the 1920s, with a frame, sawtooth-roof addition and later, in the twentieth century, with windowless brick additions to the north and northeast of the original mill. Like Hiawatha, Gibsonville Hosiery Mill lacks a free-standing cloth warehouse.

Minneola Manufacturing Company cloth warehouse remains a copious free-standing brick building of three stories with a one-story, mid-century rear addition. It retains the feeling, association, workmanship, materials, location, design, and setting of an edifice built as a storehouse for cloth in the complex of a cotton mill begun in the late nineteenth century that developed over subsequent decades. The cloth warehouse displays numerous features and design and functional elements characteristic of textile cloth warehouse architecture from the first decades of the twentieth century: slow-burn masonry construction, large operable steel windows, steel and pine columns, and kalamein doors. Modifications to the building, such as the bricked-in windows, do not detract from its significance, but highlight the types of alterations made to industrial buildings over time in order to comply with changes in technology and use. The cloth warehouse is significant for its exemplification of slow-burn construction in its materials and form and for its representation of piedmont North Carolina cloth warehouse architecture from the period.

Cloth Rooms and Cloth Warehouses at North Carolina Cotton Mills

Cotton mills throughout the state built cloth rooms or cloth warehouses as part of their plants in the late-nineteenth and first half of the twentieth century. As textile companies advanced technologically, spaces inside mills became more specialized with certain processes located in specific areas of the operation. Some cloth rooms were contained in designated areas within the confines of a main mill building or as part of a free-standing building that included spaces for other uses. Less common were buildings solely devoted to cloth storage and the materials associated with shipping and packing the cloth for transport like the one at Minneola Manufacturing Company.⁴⁰

At Loray Cotton Mills (NR 2001) in Gastonia, the main 1900-1901 five-story brick building included a cloth room at the northwest corner on the first floor below the weaving room housed on the second floor.⁴¹

⁴⁰ The author examined cotton mills on Sanborn Fire Insurance maps from every piedmont county for the period 1900 to approximately 1918, depending on on-line availability.

⁴¹ Sanborn Fire Insurance map, Gastonia, North Carolina, 1922.

United States Department of the Interior
National Park Service

National Register of Historic Places Continuation Sheet

Section number 8 Page 18

Minneola Manufacturing Company Cloth Warehouse
Guilford County, North Carolina

Loray Mill has been redeveloped in recent years and retains its main mill building. In the early twentieth century, Durham Cotton Manufacturing Company on East Pettigrew Street in Durham had its cloth room in the northwest corner of the two-story, brick weaving and carding building added to the west of the main building around 1895. The weaving and carding building containing the cloth room remains standing, but the original four-story main mill with its seven-story brick tower with belfry was demolished in 1955.⁴² Revolution Cotton Mills (NR 1984), constructed in 1899-1900 in Greensboro, included cloth rooms contained in a portion of a circa 1904 addition at the southwest corner of the main building. Revolution Cotton Mills has been renovated and now houses apartments, retail space, and offices.

Mills throughout piedmont North Carolina erected separate buildings used for cloth storage and other functions, mostly offices or shipping rooms. At Lakeside Mills (NR 1984) in Burlington, the office/cloth room is the largest support building in the complex begun in 1892. The early twentieth-century office/cloth room's four-bay façade is five bays deep and features a parapet on its north-facing façade that shields the low-pitched gable roof. The building, along with the main mill, remains intact. Windsor Cotton Mill, later known as Bellevue Cotton Mill, on Gilmer Street in Burlington includes a two-story brick office building (NR 1984) constructed in 1890. By 1908, a one-story brick cloth room was added to its east side. This originally free-standing building with two functions was connected to the larger mill by brick additions some time before 1949.⁴³ Eno Cotton Mills (NR 2011), which made gingham at its plant in Hillsborough, built its original building in 1896, but expanded it significantly in 1904. As demand for the company's gingham grew, so did the mill. The 1911 Sanborn Fire Insurance map shows three principal buildings: the main mill, a dye house, and a one-story brick building with three distinct spaces devoted to three functions: a cotton shed, supply room, and space used for shipping and as a cloth room. The former free-standing building is now surrounded by more modern additions. Established in 1886 in Burlington, Elmira Cotton Mills included a two-story brick office with an attached one-story brick cloth room.⁴⁴ This combination office and storage building stood on the opposite side of Elmira Street from the plant. It is no longer extant.

⁴² Sanborn Fire Insurance map, Durham, North Carolina, 1907; Durham Cotton Manufacturing Company, Open Durham website, accessed November 1, 2017.

⁴³ "Lafayette Holt Designs Company Shop's First Cotton Mill," *The Daily Times-News* (Burlington), July 9, 1953; Sanborn Fire Insurance map, Burlington, North Carolina, 1908; "Celanese Lanese Corporation Salutes the Centenary of Alamance County," *The Daily Times-News* (Burlington), May 9, 1949.

⁴⁴ "Cotton Mills Give City New Life After Shop's Removal," *Daily Times-News*, February 25, 1954.

United States Department of the Interior
National Park Service

National Register of Historic Places Continuation Sheet

Section number 8 Page 19

Minneola Manufacturing Company Cloth Warehouse
Guilford County, North Carolina

Free-standing buildings used solely as cloth rooms are rare at cotton mills in North Carolina. A cloth warehouse stands at Bellevue Manufacturing Company (NR 2003) in Hillsborough, Orange County. The mill added the two-story, brick cloth building to its plant in 1923. The gabled building is anchored by an elevator tower at the northeast corner and features continuous steel hopper windows. A small portion of Bellevue Manufacturing Company burned in 2016, but the cloth building remains and is undergoing restoration and renovation. The free-standing cloth warehouse at Asheville Cotton Mills is the only building from that plant to survive a 1995 fire. The two-story, brick, gable-roofed building dates to circa 1900, has metal windows, and is a contributing resource in the Riverside Industrial Historic District (NR 2004).

The Cloth Warehouse at Minneola Manufacturing Company in Gibsonville is the largest cloth storage building constructed in the first decades of the twentieth century in piedmont North Carolina. It illustrates the mill's intentional placement of its cloth storage building away from the production area and adjacent to the rail line serving the complex. The 1953 addition of a packing room and loading dock on the rear elevation signaled the shift away from the railroad as a means to ship product to using trucks for that purpose. With its wood and steel elements, wire-glass surviving windows, and metal-clad wood doors designed to close in the event of fire, the warehouse embodies the principles of slow-burn, fire-resistance construction.

United States Department of the Interior
National Park Service

National Register of Historic Places Continuation Sheet

Section number 9 Page 20

Minneola Manufacturing Company Cloth Warehouse
Guilford County, North Carolina

Section 9. Bibliography

1790 United States Federal Census, Guilford County. Ancestry.com. Accessed March 23, 2018.

"Andrew D. Gibson." U. S. Find a Grave Index. Ancestry.com. Accessed March 23, 2018.

Bishir, Catherine W. "Berry Davidson (1831-1915)." *North Carolina Architects and Builders: A Biographical Dictionary*, Copyright & Digital Scholarship Center. North Carolina State University Libraries, Raleigh, NC.

Bradley, Betsy Hunter. *The Works: The Industrial Architecture of the United States*. New York: Oxford University Press, 1999.

The Charlotte Observer. November 24, 1918.

The Daily Times-News (Burlington). February 4, 1963.

The Daily Times-News (Burlington). February 4, 1963.

The Daily Times-News (Burlington). February 25, 1954.

The Daily Times-News (Burlington). January 27, 1958.

The Daily Times-News (Burlington). January 28, 1957.

The Daily Times-News (Burlington). January 30, 1954.

The Daily Times-News (Burlington). July 9, 1953.

The Daily Times-News (Burlington). May 9, 1949.

United States Department of the Interior
National Park Service

National Register of Historic Places Continuation Sheet

Section number 9 Page 21

Minneola Manufacturing Company Cloth Warehouse
Guilford County, North Carolina

The Dispatch (Lexington). October 31, 1988.

“Durham Cotton Manufacturing Company.” Open Durham website. Accessed November 1, 2017.

Factory Insurance Association Records: 1906-1922. In the Cone Mills Records, Southern Historical Collection, UNC-Chapel Hill.

Fayetteville Weekly Observer. November 26, 1833.

Greensboro Daily News. February 15, 1914.

Greensboro Daily Workman. September 1, 1888.

The Greensboro Patriot. April 20, 1898.

The Greensboro Patriot. January 28, 1903.

The Greensboro Patriot. May 3, 1899.

The Greensboro Patriot. September 20, 1899

In the Matter of Minneola Manufacturing Company and Textile Workers Union of America (C. I. O.),
Case No. 5-R-1651, September 16, 1944, National Labor Relations Board, www.nlr.gov,
accessed April 26, 2016.

Lindley, W. Clark. E-mail communication with Richard Angino, August 23, 2013.

The North Carolinian (Raleigh). November 14, 1901.

The Raleigh Times. April 22, 1907.

The Reidsville Review. June 26, 1889.

United States Department of the Interior
National Park Service

National Register of Historic Places Continuation Sheet

Section number 9 Page 22

Minneola Manufacturing Company Cloth Warehouse
Guilford County, North Carolina

Richardson, C. T. "Kalamein Work and the Making of a Metal Covered Door." *The Metal Worker, Plumber, and Steam Fitter*. December 5, 1908.

Sanborn Fire Insurance Maps, Burlington, North Carolina, 1908.

Sanborn Fire Insurance Maps, Durham, North Carolina, 1907.

Sanborn Fire Insurance Maps, Gastonia, North Carolina, 1922.

Smith, H. McKelden, ed. *Architectural Resources: An Inventory of Historic Architecture, High Point, Jamestown, Gibsonville, Guilford County*. Raleigh: North Carolina Department of Cultural Resources, Division of Archives and History, 1979. Reprint, (by same), 1980.

Tomkins, Daniel August. *Cotton Mill, Commercial Features. A Text Book for the Use of Textile Schools and Investors*. Charlotte, North Carolina: By the author, 1899.

Western Sentinel (Winston-Salem). August 18, 1922.

Whythe, Donald. *A Dictionary of Scottish Emigrants to the USA, Volume 1*. Baltimore: Magna Carta Book Co., 1972.

The Wilmington Messenger. January 30, 1903.

Melvyn O. Wyrick. "History of the Town of Gibsonville," 1971. www.gibsonville.net. Accessed March 22, 2018.

United States Department of the Interior
National Park Service

National Register of Historic Places Continuation Sheet

Section number 10 Page 23

Minneola Manufacturing Company Cloth Warehouse
Guilford County, North Carolina

Section 10. Geographical Data

Verbal Boundary Description

The boundary of the Minneola Manufacturing Company Cloth Warehouse is shown by the bold line on the accompanying GIS map. Scale 1" = 100'

Boundary Justification

As shown on the boundary map, the nominated boundary for the Minneola Manufacturing Company Cloth Warehouse includes an approximately 1-acre portion at the northeast end of an 18-acre rectangular parcel (PIN 8835973537). It extends into the city's right-of-way, following the curb along Smith Street and briefly along East Railroad Avenue, continuing southwest to the curb along the entry drive off East Railroad Avenue. The remainder of the Minneola Manufacturing Company mill complex stands on the rest of the larger parcel and has been altered to the extent that is not eligible for listing in the National Register of Historic Places. The nomination boundary includes the historically significant Minneola Manufacturing Company Cloth Warehouse and an appropriate setting to convey its historic significance.

Minneola Manufacturing Company Cloth Warehouse
National Register of Historic Places Boundary Map



Minneola Manufacturing Company Cloth Warehouse
108 East Railroad Avenue
Gibsonville, Guilford County, North Carolina
UTM References: 17 E: 631262.63 N: 3996512.522
Scale 1"=100'



 National Register Boundary

 Tax Parcels

National Register of Historic Places
PHOTO KEY, FIRST FLOOR PLAN
Minneola Manufacturing Company Cloth Warehouse
108 East Railroad Avenue, Gibsonville, Guilford County, NC

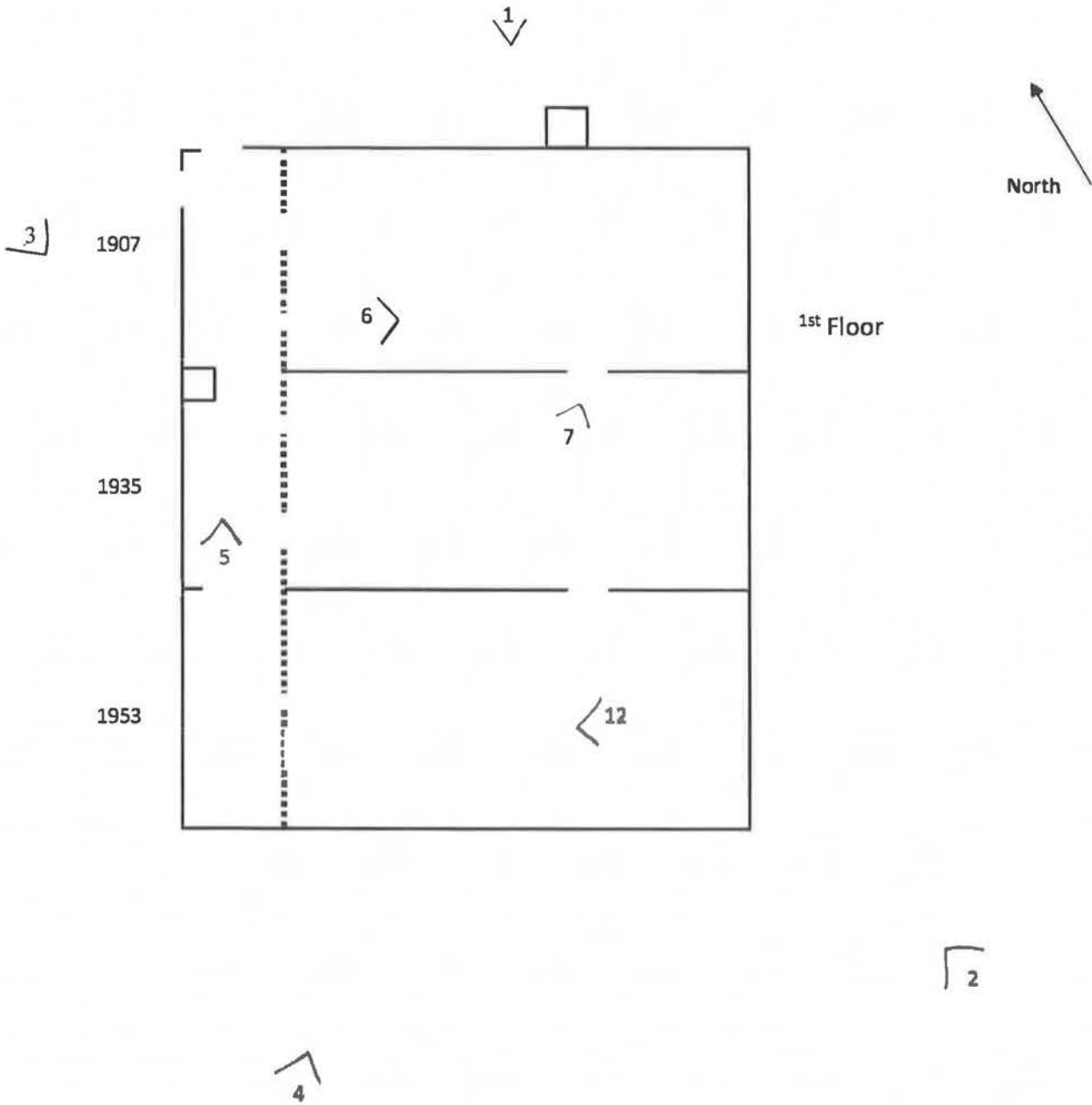

National Register of Historic Places
PHOTO KEY, SECOND AND THIRD FLOOR PLANS
Minneola Manufacturing Company Cloth Warehouse
108 East Railroad Avenue, Gibsonville, Guilford County, NC

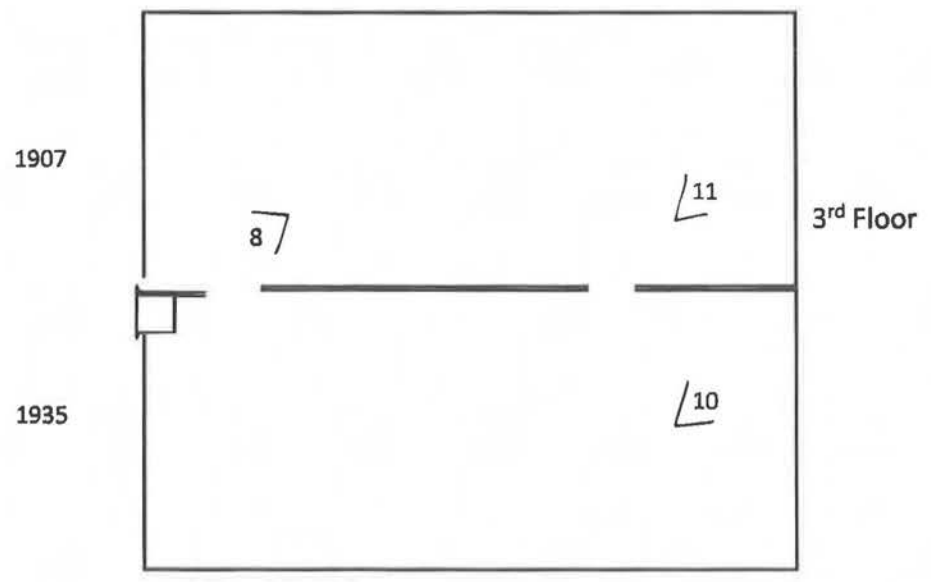
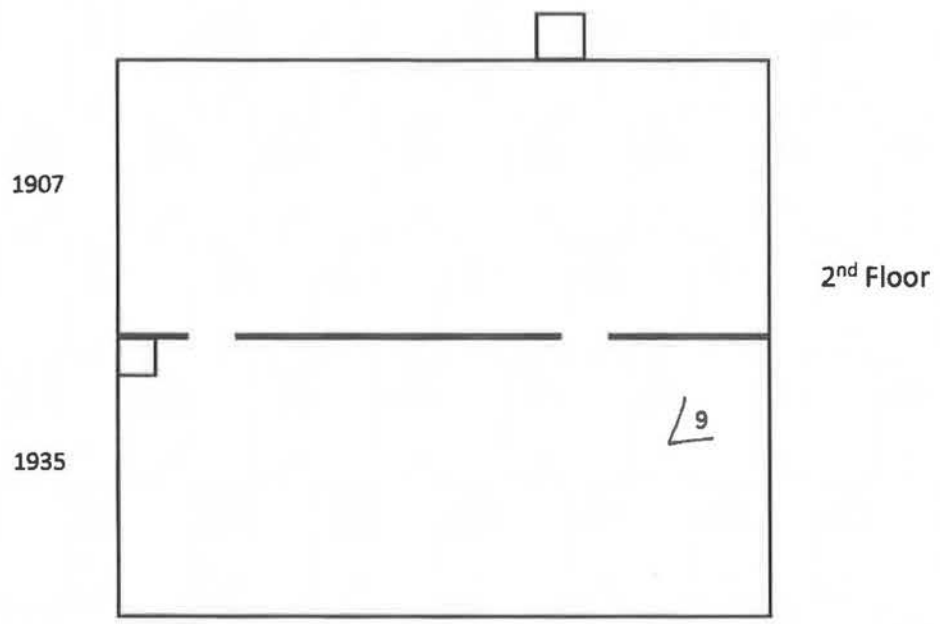

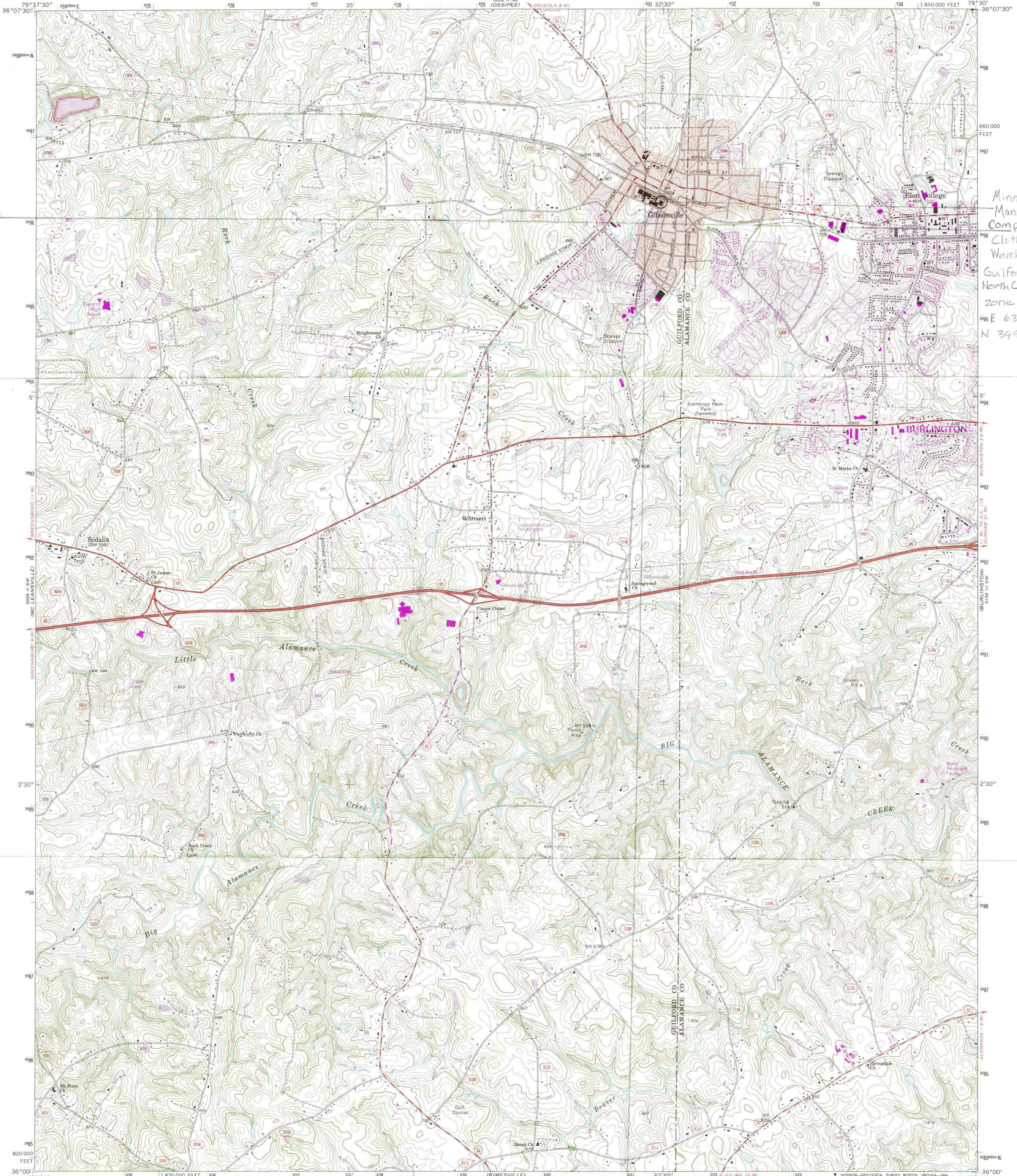

Minneola
Manufacturing
Company
Cloth
Warehouse
Guilford Co.,
North Carolina
zone 17
E 631262.63
N 3996512.522

Produced by the United States Geological Survey
Control by USGS, NOS/NOAA and North Carolina Geodetic Survey
Topography by photogrammetric methods from aerial photographs
taken 1969. Field checked 1970
North American Datum of 1927 (NAD 27). Projection and
10,000-foot ticks: North Carolina coordinate system
(Lambert conformal conic)
Blue 1000-meter Universal Transverse Mercator ticks, zone 17
North American Datum of 1983 (NAD 83) is shown by dashed
corner ticks. The values of the shift between NAD 27 and NAD 83
for 7.5-minute intersections are obtainable from National Geodetic
Survey NADCON software
Red tint indicates areas in which only landmark buildings are shown
Fine red dashed lines indicate selected fence and field lines where
generally visible on aerial photographs. This information is unchecked

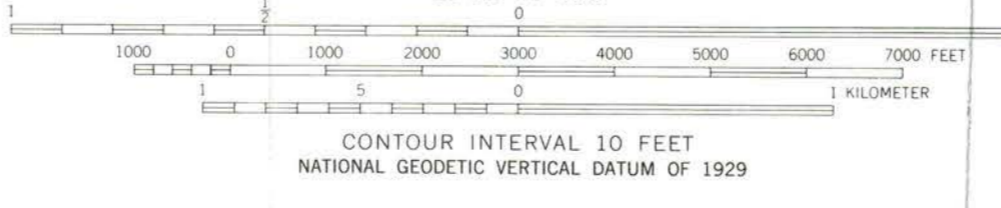

THIS MAP COMPLIES WITH NATIONAL MAP ACCURACY STANDARDS
FOR SALE BY U.S. GEOLOGICAL SURVEY
DENVER, COLORADO 80225, OR RESTON, VIRGINIA 22092
A FOLDER DESCRIBING TOPOGRAPHIC MAPS AND SYMBOLS IS AVAILABLE ON REQUEST



ROAD CLASSIFICATION

Primary highway, hard surface	Light-duty road, hard or improved surface
Secondary highway, hard surface	Unimproved road
Interstate Route	U.S. Route
	State Route

Revisions shown in purple compiled in cooperation with State of North Carolina agencies from aerial photographs taken 1991 and other sources. This information not field checked. Map edited 1994
Purple tint indicates extension of urban areas
Information shown in purple may not meet USGS content standards and may conflict with previously mapped contours

GIBSONVILLE, N. C.
36079-A5-TF-024
1970
REVISED 1994
DMA 5036 11 SE-SERIES V842

SPACE
AVAILABLE
336-584-1156

108

RAILROAD AVE





DO NOT
BLOCK
DRIVE

T















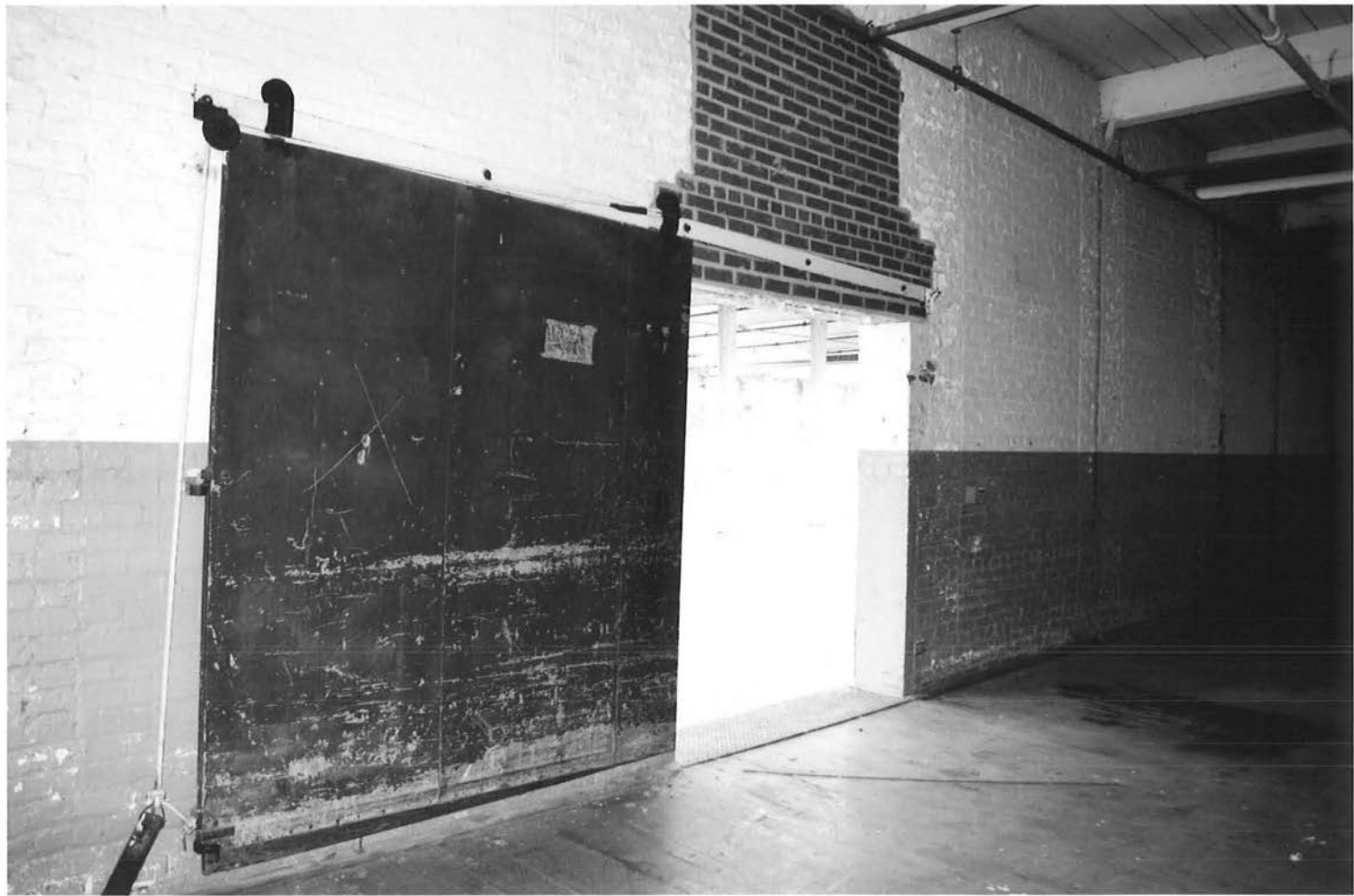



UNITED STATES DEPARTMENT OF THE INTERIOR
NATIONAL PARK SERVICE

NATIONAL REGISTER OF HISTORIC PLACES
EVALUATION/RETURN SHEET

Requested Action:

Property Name:

Multiple Name:

State & County:

Date Received: 7/30/2018 Date of Pending List: 8/27/2018 Date of 16th Day: 9/11/2018 Date of 45th Day: 9/13/2018 Date of Weekly List:

Reference number:

Nominator:

Reason For Review:

Accept Return Reject 9/11/2018 Date

Abstract/Summary Comments:

Recommendation/ Criteria

Reviewer Jim Gabbert Discipline Historian

Telephone (202)354-2275 Date _____

DOCUMENTATION: see attached comments : No see attached SLR : No

If a nomination is returned to the nomination authority, the nomination is no longer under consideration by the National Park Service.



North Carolina Department of Natural and Cultural Resources
State Historic Preservation Office

Ramona M. Bartos, Administrator

Governor Roy Cooper
Secretary Susi H. Hamilton

Office of Archives and History
Deputy Secretary Kevin Cherry

July 23, 2018

Joy Beasley, Keeper
National Register of Historic Places
National Park Service
U.S. Department of the Interior
1849 C Street NW, Mail Stop 7228
Washington, D.C. 20240

Re: Bladen County Training School – Bladen County
Minneola Manufacturing Company Cloth Warehouse – Guilford County
Oak Grove Cemetery – Wake County
Oberlin Cemetery – Wake County

Dear Ms. Beasley:

Enclosed are the nominations for the above-referenced properties to be listed in the National Register of Historic Places.

We trust you will find the nominations to be in order. If you have any questions, please contact Jenn Brosz at (919)807-6587, or jenn.brosz@ncdcr.gov.

Sincerely,

Dr. Kevin Cherry
State Historic Preservation Officer

KC/bw: enclosures