

United States Department of the Interior
National Park Service

56-2288

National Register of Historic Places Registration Form

This form is for use in nominating or requesting determinations for individual properties and districts. See instructions in National Register Bulletin, *How to Complete the National Register of Historic Places Registration Form*. If any item does not apply to the property being documented, enter "N/A" for "not applicable." For functions, architectural classification, materials, and areas of significance, enter only categories and subcategories from the instructions.

1. Name of Property

Historic name: Messina Orchard

Other names/site number: _____

Name of related multiple property listing:

N/A

(Enter "N/A" if property is not part of a multiple property listing)



2. Location

Street & number: 721-781 North Capitol Avenue

City or town: San Jose State: California County: Santa Clara

Not For Publication: Vicinity:

3. State/Federal Agency Certification

As the designated authority under the National Historic Preservation Act, as amended,

I hereby certify that this X nomination ___ request for determination of eligibility meets the documentation standards for registering properties in the National Register of Historic Places and meets the procedural and professional requirements set forth in 36 CFR Part 60.

In my opinion, the property X meets ___ does not meet the National Register Criteria. I recommend that this property be considered significant at the following level(s) of significance:

___ national ___ statewide X local

Applicable National Register Criteria:

X A ___ B X C ___ D

	<u>2/22/18</u>
Signature of certifying official/Title:	Date
<u>California State Historic Preservation Officer</u>	
State or Federal agency/bureau or Tribal Government	

In my opinion, the property <u>meets</u> <u>does not meet</u> the National Register criteria.	
Signature of commenting official:	Date
Title :	State or Federal agency/bureau
or Tribal Government	

Messina Orchard
Name of Property

Santa Clara County, CA
County and State

4. National Park Service Certification

I hereby certify that this property is:

- entered in the National Register
- determined eligible for the National Register
- determined not eligible for the National Register
- removed from the National Register
- other (explain:)

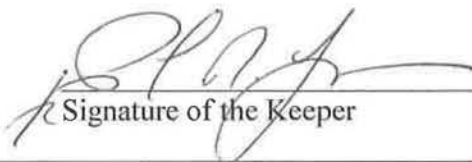
Signature of the Keeper

4/9/2018
Date of Action

5. Classification

Ownership of Property

(Check as many boxes as apply.)

- Private:
- Public – Local
- Public – State
- Public – Federal

Category of Property

(Check only one box.)

- Building(s)
- District
- Site
- Structure
- Object

Messina Orchard
Name of Property

Santa Clara County, CA
County and State

Number of Resources within Property

(Do not include previously listed resources in the count)

Contributing	Noncontributing	
<u>5</u>	<u> </u>	buildings
<u>3</u>	<u> </u>	sites
<u>1</u>	<u> </u>	structures
<u> </u>	<u> </u>	objects
<u>9</u>	<u> </u>	Total

Number of contributing resources previously listed in the National Register 0

6. Function or Use

Historic Functions

(Enter categories from instructions.)

DOMESTIC: single dwelling

AGRICULTURE/SUBSISTENCE: agricultural outbuilding

AGRICULTURE/SUBSISTENCE: agricultural field

Current Functions

(Enter categories from instructions.)

DOMESTIC: single dwelling

AGRICULTURE/SUBSISTENCE: agricultural outbuilding

AGRICULTURE/SUBSISTENCE: agricultural field

Messina Orchard
Name of Property

Santa Clara County, CA
County and State

7. Description

Architectural Classification

(Enter categories from instructions.)

LATE 19TH AND 20TH CENTURY REVIVALS: Spanish Colonial Revival

LATE 19TH AND 20TH CENTURY REVIVALS: Mediterranean Revival

Materials: (enter categories from instructions.)

Principal exterior materials of the property: WOOD: walls, siding

STUCCO: walls

TERRA COTTA: roofing/decoration

CONCRETE: paving

Narrative Description

(Describe the historic and current physical appearance and condition of the property. Describe contributing and noncontributing resources if applicable. Begin with a **summary paragraph** that briefly describes the general characteristics of the property, such as its location, type, style, method of construction, setting, size, and significant features. Indicate whether the property has historic integrity.)

Summary Paragraph

The Messina Orchard consists of a 4.96 acre, rectangular parcel of land located southeast of the intersection of North Capitol Avenue and Mabury Road, in San Jose, California. The parcel contains two houses, the 1935 Stefano and Marie Messina house, richly ornamented Spanish Revival-style residence with a 1935 matching garage; a the 1949 Richard and Marie Messina house, a well-preserved Mediterranean Revival-style residence; two equipment sheds; a water tank and numerous orchard trees in an open field between the two residences. The 1935 house has extensive and formal landscape plantings east of the residence, including a circular pathway, fountain and paired palm trees. The 1949 house also has formal landscaping and a masonry wall at the northeast corner of the site, at the intersection of North Capitol Avenue and Mabury Road. All buildings and sites date to the period of significance of the orchard's operations, 1925 to 1960.

Messina Orchard
Name of Property

Santa Clara County, CA
County and State

Narrative Description

Property Description and Setting

The Messina Orchard occupies 4.96 acres in a rectangular parcel running southwest from the corner of North Capitol Avenue and Mabury Road, in San Jose, California. The property is a rural agrarian environment surrounded by urban arterial streets and the Interstate 680 highway to the west. The property contains five buildings, the 1935 Spanish Revival-style Stefano and Marie Messina house and garage (located at 721 N. Capitol Ave.); the 1949 Mediterranean Revival-style Richard and Anita Messina house (781 N. Capitol Ave.), located at the north of the site; and two equipment sheds, constructed in 1925 and located west of the Stefano and Marie Messina house. Formal landscaping is located east of the 1935 Stefano and Marie Messina house; and is located to the north and east of the 1949 Richard and Anita Messina house. The property also contains one structure, a water tank constructed in 1925 and located north of the Stefano and Marie Messina house. Orchard trees are located in between and to the west of both houses.

Physical Description and Integrity

The following describes the individual contributing buildings, structures and sites.

1935 Stefano and Marie Messina house, garage and formal landscaping (2 buildings; 1 site)

A driveway runs from North Capitol Avenue on the south side of the property and to the 1935 Stefano and Marie Messina house and garage (**Photo 1**). The house has one site, formal landscaping and gardens, located to the east of the residence. The formal landscaping consists of a tinted-concrete walkway leading on-axis from the house's entrance porch to a fountain surrounded by boxwood hedges and a circular, tinted-concrete walkway. The walkway continues east, on-axis, to a pair of palm trees at the eastern border of the property at North Capitol Avenue. Near the palm trees are several Juniper, Redwood, Cedar, pine, pepper and Chinese Elm trees – all of which form a visual barrier between the property and North Capitol Avenue. The formal landscape also has plantings containing fountain grasses, Calla lilies, roses and seasonal flower beds, with an open lawn surrounding the concrete walkway and in between the formal plantings and the house (**Photos 2 and 3**).

The 1935 Stefano and Marie Messina house is a single-story, wood-framed residence resting on a perimeter concrete foundation. It has an irregular plan, with a cross-gable roof finished with Spanish clay-barrel tiles. A hipped roof on the rear section of the house serves the sleeping wing of the building. Exterior wall cladding is textured stucco with decorative tile inserts on the chimney and in the gable ends. Fenestration consists of arched, multi-light wood sash windows, six-over-one, double-hung wood sash windows, and multi-light wood casement windows.

The front (east) elevation faces the formal garden and consists of a triple-arched front porch framed by four spiraled columns with carved Corinthian capitals. The cross-gabled roof has two smaller gable ends intersecting and flanking the front porch. The left (south) gable end contains a bull's-eye window with a decorative iron grille, surmounted by a decorative, cement-plaster swag in the gable end. The right (north) gable end contains a recessed and arched window

Messina Orchard
Name of Property

Santa Clara County, CA
County and State

supported by decorative brackets and surmounted by the same gable-end swag detail found on the south gable end (**Photo 4**). The north elevation contains a projecting, gable-roofed wing finished in Spanish clay-barrel tiles. The east façade of this projecting wing contains a large, inset and arched window framed by a spiral detail that echoes the front columns. Located in the reentrant angle between the north elevation wall and the east façade wall of the north elevation's projecting wing, is a small corner garden separated by a low brick wall surmounted by a wrought-iron fence (**Photo 5**). The left side (south) elevation contains a side entrance into the kitchen, a wood-sash window with a multi-light and arched upper sash, diamond-shaped roof vents in the gable end and a chimney covered in textured stucco. The chimney has an arched top, with three openings above two brick bands, with decorative tile inserts set within (**Photo 6**).

Spanish Revival-style character defining features include the irregular plan, with projecting gable ends and wings; arched front porch separated with decorative cement-plaster columns; side arches with smaller, matching columns leading to landscape areas; arched chimney with decorative tile and brick insets; multiple-light fenestration expressed in arched picture windows and the top sash of double-hung windows; textured-stucco exterior wall cladding and Spanish clay-barrel tiles.

The interior of the house is in largely original condition and contains formal rooms with Spanish Revival design details, with the formal rooms separated by stepped arches and flanked by cement-plaster columns with spiral shafts and Corinthian capitals. Original hardwood flooring is also extant in the formal rooms (**Photos 7 and 8**). The living room contains a richly detailed fireplace, with a cement-plaster mantel supported by corbels, and a decorative ceramic-tile surround consisting of larger tiles depicting California missions surrounded by field tiles in various earth tones (**Photo 9**). The master bathroom contains original green and black ceramic tiles and Art Deco fixtures (**Photo 10**).

The 1935 detached garage is located southwest of the Stefano and Marie Messina house. The garage is constructed of wood-framed walls on a concrete foundation. It is L-shaped in plan with a small office or storage room to the north of the vehicle parking area. The front (east) elevation is dominated by the garage door opening framed by pilasters with triangular capitals topped with clay-barrel tiles. The walls are covered in textured stucco with clay-barrel tiles to match the adjacent house (**Photo 11**).

The 1935 Stefano and Marie Messina house is in excellent condition, with no significant alterations to the building. Wood sash and wood casement windows are original to the building and in operable condition. The 1935 garage is in excellent condition with replacement of the front garage door in 1960. Both the house and garage maintain integrity of location, design, settings, materials, workmanship, feeling and association.

1949 Richard and Anita Messina House and formal landscaping (1 building; 1 site)

The 1949 Richard and Anita Messina house is located at the northeast corner of the site, near the intersection of North Capitol Avenue and Mabury Road. Two driveways enter the property, one from the north side on Mabury Road and another driveway leading to the east elevation at 781 N.

Messina Orchard

Name of Property

Santa Clara County, CA
County and State

Capitol Ave. A brick-landscaping wall runs along the north and east property lines, connecting the two driveway entrances, which are flanked by brick entrance piers. The house is a two-story residence, irregular in plan, constructed with wood-framed walls resting on a perimeter concrete foundation. Roof massing is complex, with a combination of hipped and shed roofs finished with clay-barrel tiles. A flat stucco finish covers the exterior walls. The roof eaves have exposed rafters. Fenestration consists of original multi-pane, steel casement windows.

The front (north) elevation consists of a projecting, hipped-roof single story, with a front porch on square columns with bracketed capitals. Entrance to the house is to the side of the front porch. A projecting, hipped-roof single-story mass is located west of the porch and contains an arched window. A decorative brick base course runs along the north elevation. The upper story is set back from the first, with corner loggias supported by square columns with brackets that match the porch below. A second-floor window with decorative wrought iron railings is centered between the two corner loggias (**Photo 12**).

The right side (east) elevation consists of the projecting and irregular hipped and shed roofs, surmounted by the two-story building mass. A two-car garage occupies the south side of the east elevation, with a recessed entrance to the north (**Photo 13**).

Mediterranean Revival-style character-defining features include asymmetrical roof massing, clay-barrel roof tiles, recessed upper story with corner loggias, arched windows, decorative wrought iron railings on the upper loggias and stucco exterior wall cladding.

The house's interior features an original kitchen with a Streamline Moderne-style rounded kitchen cabinet and original tile work (**Photo 14**). Original hardwood floors remain, and the original staircase with wrought iron railing (**Photo 15**). The family room contains Mid-Century Modern-style interior features, including curved glass and metal ceiling beams (**Photo 16**). Nearly all of the interior furnishings are original to the house and date to the Richard and Anita Messina period of occupation.

The brick-landscaping wall running along the northeast side of the property and mature trees provide a visual barrier from the street. Formal landscaping is located behind the walls to the north and east of the house, with lawns planted between the house and landscaping. Tree species consist of several Pine trees, Redwood trees, smaller palm trees, junipers, White Birch trees, Camphor trees, and Modesto Ash trees. Boxwood hedges run along the driveways and demarcate planted areas consisting of Jacaranda trees, flowering plum trees and seasonal flower beds.

The 1949 Richard and Anita Messina house is excellent original condition with two alterations. A small, upstairs bedroom was added to the southeast corner of the east elevation above the garage (1960); and the multi-paned, arched window on the north elevation has been replaced with fixed glass (1960). Despite these alterations, the house maintains integrity of location, design, settings, materials, workmanship, feeling and association. The building maintains a high degree of integrity of design, materials and workmanship, with the second-story addition

Messina Orchard
Name of Property

Santa Clara County, CA
County and State

designed in keeping with the *Secretary of the Interior's Standards*, as it used the same materials and the same casement window design.

Multi-Bay Equipment Shed (1925 – 1 building)

The Multi-Bay Equipment Shed is a long, rectangular building located west of the 1935 Stefano and Marie Messina garage. The shed has a cross-gable roof finished with corrugated metal and exterior walls covered in vertical wood siding. The east elevation is a four-bay composition with square columns creating the stalls for the storage of farm equipment (**Photo 17**). The shed is in good condition and maintains integrity of location, design, settings, materials, workmanship, feeling and association.

Single-Bay Equipment Shed (1925 – 1 building)

The Single-Bay Equipment Shed is a smaller, rectangular building located north of and adjacent to Equipment Shed 1. This structure also has a gable roof finished with corrugated metal and wood-framed walls finished with vertical board siding. The cross-gabled shed is open on both the north and south elevations, allowing for a tractor to drive through the building and access the surrounding orchard (**Photo 18**). The shed is in good condition and maintains integrity of location, design, settings, materials, workmanship, feeling and association.

Water Tank (1925 – 1 structure)

A circular Redwood water storage tank with a conical sheet metal roof and resting on a concrete foundation is located north of the Stefano and Marie Messina house. The foundation was constructed in 1925, with the water tank replaced in 1960. The water tank is in good condition and maintains integrity of location, design, setting, materials, workmanship, feeling and association (**Photo 19**).

Orchard (1925 – 1 site)

Approximately 4 acres of mature orchard trees surround the water tank and run between and west of the two houses (**Photo 20**). A number of the extant orchard trees are part of the original orchard planted by Stefano Messina in 1925. The remaining trees were transplanted to the south and west areas of the site when the larger Messina property holdings were subdivided in 2000. Extant orchard tree species include 25 Apricot trees, 15 Prune trees, 15 Walnut trees, 15 Olive trees, 6 Peach trees, 6 Cherry trees, 5 Fig trees, 2 Apple trees, 2 Mulberry trees, 3 Quince trees, 2 pear trees and 2 pear trees.

Historic Integrity of the Site

All extant buildings and sites listed above are in their original setting and original locations. The 1935 Stefano and Marie Messina house and garage are in nearly original condition with a high degree of integrity of design, materials, workmanship, feeling and association.

Messina Orchard
Name of Property

Santa Clara County, CA
County and State

Despite the small upstairs addition (1960) to the 1949 Richard and Anita Messina house and a single window replacement (1960), this building is in largely original condition and possesses a high degree of integrity of design, materials, workmanship, feeling and association.

The two remaining farm buildings were used actively during the operation of the Messina Orchard. The 1925 Multi-Bay Equipment Shed and 1925 Single-Bay Equipment Shed (tractor shed) possess a high degree of integrity of design, materials, workmanship, feeling and association.

The 1925 water tank also maintains integrity of location, design, materials, workmanship, feeling and association. The tank resting on top of the original foundation was replaced in 1960.

Between 1925 and 1927, Stefano Messina constructed the fruit processing operations of the orchard adjacent to and southeast of the driveway leading to the 1935 Stefano and Marie Messina house. This included the construction of a wood-framed, corrugated-metal clad fruit processing building facing North Capitol Avenue, and three fruit dehydrators located behind (west) the fruit processing building. Fruit harvested from the orchard trees on the adjacent land was sorted, processed and packed for delivery inside the fruit processing building. Fruit chosen for drying was sorted to be laid in large trays in the sun, sold for canning, or sent to the dehydrators behind the fruit processing building.

In 2001, the Santa Clara Valley Transportation Authority expanded its Capitol Light Rail system along North Capitol Avenue. Installation of light rail tracks in the median of the road required substantial widening of North Capitol Avenue. At this time, the Messina family subdivided their larger property holdings, including the fruit processing building and dehydrators, allowing for installation of the Capitol Light Rail system. The fruit processing building and dehydrators were removed for this project's construction in 2001.

Messina Orchard
Name of Property

Santa Clara County, CA
County and State

8. Statement of Significance

Applicable National Register Criteria

(Mark "x" in one or more boxes for the criteria qualifying the property for National Register listing.)

- A. Property is associated with events that have made a significant contribution to the broad patterns of our history.
- B. Property is associated with the lives of persons significant in our past.
- C. Property embodies the distinctive characteristics of a type, period, or method of construction or represents the work of a master, or possesses high artistic values, or represents a significant and distinguishable entity whose components lack individual distinction.
- D. Property has yielded, or is likely to yield, information important in prehistory or history.

Criteria Considerations

(Mark "x" in all the boxes that apply.)

- A. Owned by a religious institution or used for religious purposes
- B. Removed from its original location
- C. A birthplace or grave
- D. A cemetery
- E. A reconstructed building, object, or structure
- F. A commemorative property
- G. Less than 50 years old or achieving significance within the past 50 years

Areas of Significance

(Enter categories from instructions.)

ARCHITECTURE

AGRICULTURE

Messina Orchard
Name of Property

Santa Clara County, CA
County and State

Period of Significance

1925 - 1960

Significant Dates

1925: Construction of two Equipment Sheds
1935: Stefano and Marie Messina House
1949: Richard and Anita Messina House

Significant Person

(Complete only if Criterion B is marked above.)

Cultural Affiliation

Architect/Builder

1935 Stefano and Marie Messina House: Richard Messina/ George Martin Landscape Design
1949 Richard and Anita Messina House: Vincent J. Sunzeri

Messina Orchard
Name of Property

Santa Clara County, CA
County and State

Statement of Significance Summary Paragraph (Provide a summary paragraph that includes level of significance, applicable criteria, justification for the period of significance, and any applicable criteria considerations.)

The Messina Orchard is eligible for the National Register of Historic Places at the local level of significance under Criterion A, in the area of Agriculture, for its association with the agricultural development of the Santa Clara Valley. The property is also eligible for the National Register of Historic Places at the local level under Criterion C in the area of Architecture, for its two intact, period revival single-family residences, formal landscaping, extant farm buildings and orchard trees. Two generations of the Messina family worked the orchard. Stefano and Marie Messina constructed the 1935 Stefano and Marie Messina house and formal gardens as a distinctive and representative example of the Spanish Revival style. The residence possesses a high degree of historic integrity. Richard Messina, Stefano Messina's son, constructed the second family house, the 1949 Richard and Anita Messina house, as a distinctive and representative example of the Mediterranean Revival style, with Mid-Century Modern interior details. The district also contains two agricultural buildings, an agricultural structure, original farm equipment and orchard trees from when the Messina Orchard employed up to 25 persons in the cultivation and processing of fruit, contributing to the vast fruit production that earned the Santa Clara Valley the name, "Valley of Heart's Delight." The period of significance is 1925 to 1960, and spans the construction date of two farm buildings, the construction of the 1935 Stefano and Marie Messina house and the 1949 Richard and Anita Messina house, and to the year when fruit production had declined substantially in the Santa Clara Valley, as post-World War II industrial growth and suburban expansion replaced the orchards with roadways, subdivisions and industrial parks.

Narrative Statement of Significance (Provide at least **one** paragraph for each area of significance.)

Criterion A: Agricultural Association

Development of the Messina Orchard Buildings

In 1905, Stefano and Marie Messina emigrated as children from Sicily and settled in the Santa Clara Valley. Following their marriage in 1922, Stefano and Marie Messina purchased 40 acres of orchard land that contained the subject property and was owned by local horticulturist Floyd Lundy. At this time the Lundy property was an established orchard stretching southwest from the intersection of North Capitol Avenue and Mabury Road near the hamlet of Berryessa, northeast of downtown San Jose. The Messinas purchased additional lands in the Berryessa area, planted orchard trees and developed the combined properties into their orchard operations, known as "Messina Orchards."

While the additional land holdings were planted with various orchard trees, the fruit processing operations were located on the subject property. Beginning in 1925, Stefano Messina constructed the functional buildings of the orchard, including the extant single-bay and multi-bay equipment sheds, and the water tank. Stefano Messina planted prunes, apricots and peaches on the orchard property in the 1920s. Between 1925 and 1927 he constructed a wood-framed and corrugated-metal clad fruit processing facility along with mechanical fruit dehydrators, a rail system and

Messina Orchard

Name of Property

Santa Clara County, CA
County and State

infrastructure immediately southeast of the extant 1935 Stefano and Marie Messina house and facing North Capitol Avenue, for easy access to fruit delivery trucks. The fruit processing facility and dehydrators were in operation until 1990.¹

While the multi-bay equipment shed housed individual farm vehicles and equipment in the various stalls, the design and orientation of the single-bay equipment shed is deliberately open, allowing for a tractor and sprayer to be pulled straight into the shed from either side of the property. The Messina Orchard produced and processed apricots, prunes, cherries and walnuts. The orchard trees were planted in sections organized by tree type around the 40-acre property. Approximately 4.5 acres of orchard trees remain, many in their original locations as planted in 1925.

Stefano and Marie Messina occupied the extant Lundy house on the property until 1934, when fire destroyed the building. In 1935, Stefano Messina constructed the richly detailed, Spanish Revival-style Stefano and Richard Messina house as the Messina family residence. Family oral history indicates that Stefano dispatched his son Richard (then 22 years old) to look for a suitable architectural style (**Figure 2**). After tours of southern California viewing architecture, Richard Messina aided Stefano in choosing the Spanish Revival Style for their new home. The house was completed in 1935 and was constructed by local contractor George Martin, who appears to have aided in design of the formal gardens east of the house (**Figure 3**).

Stefano Messina ran the orchard's daily operations, while Marie Messina handled bookkeeping and administrative duties. Stefano and Marie Messina raised seven children in the 1935 family house, just steps from the active orchard. Stefano taught his two sons, Richard and Anthony, how to manage the orchard, drive tractors, oversee production and negotiate sales. Marie tasked her daughters, Victoria, Josephine, Lillian, Marie and Eleanor, with assisting her in administrative duties and with the daily fruit processing operations, including the cutting, sorting and packing of apricots, cherries and other orchard products.

Stefano Messina died in 1946, leaving the orchard to his son Richard Messina. Richard Messina (1912-2001) and his wife, Anita, managed all orchard operations and staff until commercial production was stopped circa-1990. In 1949, Richard and Anita Messina constructed the family's second-generation house, the Richard and Anita Messina house, on the northeast corner of the property. Richard Messina chose a two-story residence, constructed in the Mediterranean Revival Style with Mid-Century Modern interior design details. The contractor was local builder Vincent Joseph Sunzeri.

Richard and Anita Messina had three daughters: Marilyn, Diana and Stephanie. Richard took on his father's role of managing the daily operations of the orchard, while Anita and her daughters worked in the sorting, packing and processing of the orchard products.

¹ Interview with Marilyn Messina, Richard Messina's daughter, 1999, confirms the closing date of operation. The fruit processing facility, dehydrators and infrastructure were removed for the City of San Jose's Capitol Light Rail Project in 2001.

Messina Orchard
Name of Property

Santa Clara County, CA
County and State

Richard Messina and his family participated daily in the operations of the orchard. Richard was known as an active and caring boss and was frequently seen working with his employees throughout the orchard (**Figure 4**). Richard Messina was known for adapting the region's technological advancements to his orchard operations. He was one of the first orchardists to use the John Deere Sub-soiler, a tractor-pulled rotary tiller that penetrated the soil at greater depths, allowing for more water penetration and greater tree growth. Richard Messina was a highly regarded regional orchardist and was featured in various journal articles.² For over fifty years, Richard and Anita Messina operated fruit production, dehydration, packing and sales, building a successful family business served by two generations. Messina Orchards sold its fruit products to all of the major packinghouses in the Santa Clara Valley, including Dole, Del Monte, Mayfair and Glorietta.

Messina Orchard Operations

In addition to the family members, the Messina Orchard employed a regular crew of about twenty men all year. The men were mainly Italian, Mexican and Portuguese locals that would remain with the Messina Orchards for their entire career. During the harvest season from May until early August, the Messina Orchard was a beehive of activity with neighborhood women sorting, packing and processing the fruit, while their children played in the adjacent gardens. The Orchard also hired migrant Mexican families during the harvest season; many of them forming lasting relationships with the Messina family and returning for the next year.

The Messina Orchard operations were conducted southeast of the 1935 Stefano and Marie Messina House. A driveway located at the southeast corner of the site served as access to both the house to the north and the fruit processing facility and dehydrators to the south. A low concrete wall once separated the residential and operational sides of the orchard.

Apricots and prunes were the primary orchard products, along with peaches, cherries and walnuts. After being harvested from trees in the field by seasonal and permanent workers, the product was sorted, graded for various sale categories, and either laid out in large trays in the fruit processing facility, or placed in the adjacent dehydrators. English walnuts were dried, hulled and packed in this building also. During the harvest, fruit-drying trays were laid out in areas to the south of and behind the fruit processing facility.

Equipment was used regularly throughout the daily orchard operations and stored primarily in the multi-bay equipment shed. The single-bay equipment shed was known as the tractor shed and had a pass-through design that allowed the tractor to drive in both directions to different areas of the orchard.³

Tending to the orchard trees at all times of the year was a family operation. Smudging was a process of protecting orchard trees from frost destruction during the winter months. After

² See "R.V. Messina – New Developments – Sound Experience," *Clara-Benito Farm Journal*, October 1952. Richard Messina was also photographed casting a ballot for the 1951 California Measure for Dried Prunes in an article for the *San Jose Mercury News*, October 14, 1951.

³ Interviews with Marilyn Messina, 3/29/16 and 4/18/17 and additional dates.

Messina Orchard

Name of Property

Santa Clara County, CA
County and State

smudging of citrus trees was developed in southern California in the 1920s, it was practiced regularly in Santa Clara Valley orchards. A smudge pot is a large vessel containing oil with a chimney in the center. When the oil is burned, the vapor and particulates from the process “smudge,” or forms a protective blanket that prevents rapid cooling of the trees during the colder winter nights. A large orchard contained numerous smudge pots placed in rows between the trees. At the Messina Orchard in the evening, all family members, including the children were given a lighted torch and told to race down the rows of trees to light the smudge pots. The children would race into the fields to be the first to light all of his or her rows of smudge pots. An honor was bestowed on the child who lit all of his or her smudge pots first.⁴

Marilyn Messina, Richard Messina’s daughter, lived on the ranch throughout her childhood and notes that some of the orchard’s employees worked for the Messina family for over 55 years. Ethnicities of permanent and seasonal employees followed the trends of worker development in Santa Clara Valley horticulture, including both Italian and Mexican immigrants. Her insights into the people working for her father are illustrative:

Messina Orchards was supported by countless "hands" that worked alongside my grandfather and father throughout the span of nearly one hundred years of harvesting fruit in the Santa Clara Valley. The hands of Rufino and Martin Aguilera, two brothers from Mexico who spent fifty-five years as trusted year round foremen. They oversaw all operations and the hiring of seasonal workers during the harvest time. The hands of Alfonso Chiodo and Tony Lopez driving the tractor and hauling tons of fruit on army surplus trucks to the local canneries, including Mayfair Packing, Dole, Barron Grey, and Glorietta. The hands of Manuel Lopez, Pete Ramirez, Joe Lazara, Dominic Taormina, Terry La Rosa, Joe Terry and Jose Montona that moved irrigation pipes, ladders, props, and hundreds of cannery boxes. Hands that pruned hundreds of acres of fruit trees in the winter cold, stood along the tractors as they pulled the big sprayers through rows and rows of fruit trees in rubber slickers, boots and hats. The hands that dipped prunes, sulfured apricots, hulled walnuts and the local women who packed cherries and cut apricots each May, June and July.

The seasonal workers who came to harvest the crops during those unforgettable summers often camped on the property. They were usually large families with many children and extended family members. The Rugia family, the Chavez family and the many others whose names I cannot recall but whose faces I shall never forget. Each summer we grew a little older and taller and even though many did not speak any English we would play together in the orchards and when the day's picking was over the families would gather in a circle for dinner and play guitars and sing. Together they picked tons of cherries, apricots, peaches, prunes and walnuts. By October the harvest was ended and they returned home.⁵

⁴Interview with Marilyn Messina, electronic correspondence, 9/22/17.

⁵ Correspondence from Marilyn Messina to Seth Bergstein, 4/25/17.

Messina Orchard
Name of Property

Santa Clara County, CA
County and State

The Messina Orchard provides an extant window into two family generations of agricultural development in the Santa Clara Valley. The orchard was owned and operated by Italian immigrants who brought agricultural practices from their native country and then adopted new farming techniques and methods to develop the Santa Clara Valley into one of the richest fruit-producing regions in the United States. Stefano and Marie Messina developed the Messina Orchard into a thriving horticultural operation in the 1930s and 1940s, particularly taking advantage of the demand for canned and dried fruit created by World War II. Following the war, Richard and Anita Messina took over the orchard, representing the second generation of the Messina family that would work the land. Running the orchard was a family affair, with all members and children assisting in orchard operations. In addition, a regular staff of twenty men was employed on a yearly basis, as well as the employment of numerous regional and migrant workers during the harvest season. The extant houses, extant agricultural buildings and the numerous apricot, prune and other fruit trees on the property are a record of two generations of family participation in the Santa Clara Valley fruit industry.

Background: Historical Summary of the Santa Clara Valley Fruit Industry **Early Development of Fruit Production**

Until the 1880s, commercial agricultural production in the Santa Clara Valley relied on wheat and cereal crops, with Santa Clara County becoming the fifth largest wheat producer in the State of California. By the early 1880s, the development of the cereal market by growers in the Midwest led to more competitive prices and West Coast wheat production began to decline. This heralded a shift to horticulture and fruit growing in the Santa Clara Valley.⁶

Developments in fruit horticulture for the Santa Clara Valley began in earnest when Louis Pellier grafted his French Prune variety onto domestic plum stock, creating a heartier and more flavorful prune. Ballou successfully dried the fruit in small quantities and sold them to the San Francisco market in 1867. In 1868 Ballou dried eleven tons of various fruits and shipped them around the Horn to New York City in a profitable venture. In the following two decades, Santa Clara Valley farmers slowly turned to fruit growing as a means of agriculture.⁷

The next step in the development of horticulture in the Santa Clara Valley centered upon getting the ripened fruit to the market. With drying one option already proven to be successful by Ballou, James Madison Dawson, a Maryland native, developed a crude cannery in his kitchen in 1871. Madison shipped 350 cases of canned fruit in his first year, and represents the birth of the canning industry in the San Jose region. In 1873 Dawson opened the J.M. Dawson & Co. cannery, occupying a new brick building in downtown San Jose. That year they produced 8,000 cases of canned fruit for the regional market. By 1887 when the cannery was operated by his widow and son, the company turned out approximately 140,000 cases.⁸

⁶ Stephen M. Payne, *Santa Clara County Harvest of Change*, 1987, 71.

⁷ Clyde Arbuckle, *Clyde Arbuckle's History of San Jose*, 1985, 155.

⁸ Arbuckle, 156.

Messina Orchard

Name of Property

Santa Clara County, CA
County and State

The first substantial commercial success in prune production occurred in 1881 when E.L. Bradley harvested his 10 acres of French prunes for a return of nearly \$4,000, a substantial sum at the time. Bradley's success proved the profitability and adaptability of the French prune to the Santa Clara Valley. By 1895 the Santa Clara Valley became known as the prune-growing center of the world with over 4.5 million prune trees. In addition to the prune tree, apricots, cherries, plums and peaches were developed and planted in the millions to be dried and shipped to eastern and worldwide markets. The rising demand for dried fruit during World War I boosted demand substantially as well.

The primary issue with fruit production and profitability was overproduction and spoilage of the product before it could reach the market. Growers relied on three methods to maximize production and sales: drying, canning and refrigerated railroad cars. With early developments in fruit drying proving to be successful, shipping the fruit to market before the product spoiled was the next challenge. Levi Ames Gould invented the first crudely refrigerated rail cars to keep the fruit fresh for the long rail journey. The *California Farmer* noted the achievement on August 11, 1870. By the end of 1871 the journal reported that Gould had shipped 30 carloads of fresh fruit that year. By 1876, San Jose was the largest fruit shipping city in California, with railroad statistics listing the top three origin points of fruit traffic being San Jose, followed by Sacramento and Marysville. By 1881, over 100 carloads of fresh and dried fruits were shipped from San Jose to eastern markets. Gould's innovation is part of a long list of horticultural and technical advancements in fruit growing and processing that would characterize the fruit growers of the Santa Clara Valley during its heyday of development, 1880 – 1945, when the region earned the nickname, Valley of Heart's Delight.

Technological and Social Advancements in Horticulture

Technological advancement in the science of horticulture and methods of fruit preservation characterized fruit production in the Santa Clara Valley. With the success of early fruit growers such as E.L. Gould, farmers in the valley sought to improve on the earlier fruit drying methods. Early methods, including the use of dehydrators, led to significant loss of product. Pioneers such as John Ballou found that dipping prunes in a lye solution allowed the skin to crack, allowing quicker drying before the fruit fermented. This earliest drying method involved dipping the prunes into a lye solution, placing them in trays and allowing them to dry in the sun. The sun-drying method remained the regional practice until 1918 when an uncanny September rainstorm lasting three days destroyed much of the year's fruit crop, which was drying in the open sun. The disaster cost local growers millions of dollars, leading to the continuous development of mechanical dehydrators by local growers, who often also became inventors.

Innovations in mechanization would characterize the technological development of fruit production in the region. The region's growers and machinists, all in an effort to maximize production and profit, would examine nearly every process of fruit production, from drying to shipping. During the peak periods of fruit production, innovation occurred constantly. Joseph Amori of the California Packing Corporation developed a machine to cut and pit apricots, one of the few inventions still used today. Los Gatos inventor John Bean used his previous invention of a well water pump to develop the first fruit sprayer used commercially in the Santa Clara Valley.

Messina Orchard
Name of Property

Santa Clara County, CA
County and State

His invention would lead to the development of his Bean Spray Company, which built its first factory in San Jose on Julian Street. At the time of Bean's death in 1908, his company was the largest spray pump company in the world. The Bean Spray Company absorbed other companies that started out with singular technical innovations in horticulture, including a tractor developed by Alfred Johnson, which used crawler-type wheels with treads to better handle the wet soil conditions often found in the valley.

In 1888 Luther Cunningham invented the mechanized prune dipping machine, using hinged metal baskets to bathe the prunes in the lye solution in large quantities. He joined with W.C. Anderson in 1902, forming the Anderson Barngrower Manufacturing Company. In 1910 the company constructed a large factory in San Jose, near the Southern Pacific Railroad yard on Julian Street. The company also developed additional machinery for the region's fruit production, including the continuous can sterilizer, which sterilized, cooked and cooled cans in one process. In 1928, the Anderson Barngrower Manufacturing Company merged with the Bean Spray Pump Company and the Smith Manufacturing Company, renaming the conglomerate the Food Machinery Company (FMC). FMC would become one of the largest fruit processing machinery companies in the world.⁹

By 1900, the vast quantity of fruit grown and processed in the Santa Clara Valley led to the typical problems of supply, demand and democratizing profits to the region's vast number of growers. The development of cooperatives among growers became the solution. John Z. Anderson formed the California Fruit Union in 1883 to tackle the economic problems. This small cooperative was overshadowed by Philo Hersey's Santa Clara County Fruit Exchange, which incorporated in 1892. The cooperative grew to include 436 regional growers, from Willow Glen to Berryessa, and constructed a large fruit packing plant on Sunol Street in San Jose.

Prunes would demand their own cooperatives, as the Valley was producing nearly three-fourths of California's prunes by 1900. By 1915, the Santa Clara Valley Fruit Exchange dissolved leading to the development of the California Prune and Apricot Growers, Inc. in 1917. The cooperative sought to be the leading Santa Clara Valley cooperative by regulating the quality of all fruit produced by its growers, standardizing the product and negotiating freight shipping fees, all with the goal of democratizing proceeds for the region's growers. The organization would develop and market its Sunsweet brand, which remains in production today.¹⁰

Valley of Heart's Delight: 1890 - 1945

The developments in irrigation, horticultural technology and transportation laid the foundation for fruit supply and production in the Santa Clara Valley. The demand created by eastern markets and two world wars would provide the market for the meteoric development of the Santa Clara Valley into the nation's leading producer of fruits and nuts from the end of the 19th Century until the close of World War II. Markets were both local and widespread, from the local and regional fruit stands and grocers to the large regional markets of San Francisco and Los Angeles. Even

⁹ Payne, 146.

¹⁰ Arbuckle, 160.

Messina Orchard

Name of Property

Santa Clara County, CA
County and State

before World War I, northern Europeans enjoyed canned fruit from one of the numerous San Jose canneries constructed to process the seemingly endless amount of fruit.¹¹

By 1890, the Santa Clara Valley boasted 4,454,945 fruit trees, with orchards spreading across the valley in seemingly endless numbers. Nearly 3,000,000 of these trees were prune trees. By 1900, the number of fruit trees reached 4,788,615, with 2,718,600 prune trees and increasing numbers of apricot, peach and cherry trees. Demand for fruit production hit a peak due to the need for dried fruit for World War I, but declined with the close of the war. The peak of fruit production in the Santa Clara Valley occurred in 1925, with 6,959 farms producing fruit in the valley. With the substantial demand provided by American and European markets during World War II, the amount of horticultural acreage in the Valley would rise steadily into the 1940s, with 59,494 acres planted in prunes, 18,584 acres planted in apricots, 7,511 acres planted in pears, and 2,628 acres planted in cherries. When Stefano Messina came to the Valley in 1922, he arrived during a time of fertile fields and a promising market open to the development of the Messina Orchard.¹²

Decline of Fruit Production in the Santa Clara Valley: 1945 – 1970

The end of World War II is considered to be the beginning of the demise of the Santa Clara Valley's fruit industry. Demand for dried and canned fruit reduced considerably following the end of World War II, causing a significant fall in canned and dried fruit prices and leaving the region's growers with significant problems of overproduction for reduced demand. This combined with changing development in the Santa Clara Valley toward industry and technology, which had begun during World War II.

During World War II, the Santa Clara Valley became active in developing technology and industry in support of the war effort. Nearby Moffett Field was one of the major bases of the United States Army-Air Corps, with substantial development occurring in the years 1935 to 1942. To support the war effort, over seventy new industrial plants were constructed in the Santa Clara Valley during wartime. In San Jose, nearly 9 million dollars was invested in new industrial plants for the production of metals and plastics for military and industrial use. Existing plants that innovated horticultural equipment were converted for wartime production. One example is the Food Machinery and Chemical Corporation (FMC) facility, which was converted for tank production in 1943. The opening of the International Business Machine Corporation in 1943 set the stage for the Valley's burgeoning technological developments in computers and information science that continues today. Between 1945 and 1965 more than 550 new industries moved into the Santa Clara Valley. Many of these industries were constructed on converted orchard land.¹³

The acute housing shortage for returning military personnel and their families following World War II and a vastly expanding population in the 1950s and 1960s contributed substantially to the decline in the Santa Clara Valley fruit industry. With a shift in the labor pool toward manufacturing, research and development, new roadways, housing developments and shopping centers replaced the valley's vast orchards.

¹¹ Yvonne Jacobson, *Passing Farms, Enduring Values*, 1984, 164.

¹² Arbuckle, 163.

¹³ Payne, 168.

Messina Orchard
Name of Property

Santa Clara County, CA
County and State

Fruit acreage figures provide an indication of the decline. Prune acreage in the Santa Clara Valley reached 59,494 acres in 1940, declining to 18,900 acres by 1970. Similarly, acres planted in apricots peaked in 1940 at 18,584 acres, declining to 5,215 acres by 1970.¹⁴ As the demand for fruit declined nationwide, the suburbanization and industrial development of the Santa Clara Valley led to a rise in property values. This combination of factors shifted the horticultural industry to the Central Valley, where land was cheaper and not under the threat of suburbanization.

Cities in the Santa Clara Valley adopted aggressive annexation strategies to enlarge their tax bases for growing city operations. One example of city annexation practices that consumed vast tracts of agricultural land was the City of San Jose and its City Manager, A.P. “Dutch” Hamann, who presided over the city in the 1950s and 1960s. Under Hamann’s tenure, the City of San Jose annexed enormous tracts of orchard land for construction of new roads, shopping centers and housing subdivisions, transforming the Santa Clara Valley into the sprawling metropolis that exists today.¹⁵

Ethnic Groups Contributing to Santa Clara Valley Fruit Production

Various ethnic groups changing over time formed the vast labor force for Santa Clara Valley fruit production. From the 1880s until about 1900, Chinese men moved from the railroad workforce to the Santa Clara Valley. In 1870 Santa Clara County had about 104 Chinese farm workers, with the number growing to 2,723 in 1890. With the passage of the Chinese Exclusion Act in 1882 and various Chinese exclusion policies in California in the 1880s, the Chinese labor force began to leave the Santa Clara Valley, with nearly complete departure of the ethnic group by 1900.

By around 1908, Santa Clara Valley farmers hired few, if any, Chinese laborers, switching to Japanese immigrants to provide their labor force. Reportedly, the 1915 prune harvest was accomplished almost exclusively by Japanese laborers, who were willing to work for a paltry two dollars per day, far below what white laborers were willing to make. In the 1920s and 1930s Filipino and Mexican immigrants joined the workforce.¹⁶

Fruit production is a labor-intensive and seasonal operation. During the peak of the harvest, vast amounts of labor were required to pick, dry, process and pack the fruit for delivery. The demand for labor would reduce dramatically after the harvest; thus, seasonal or migratory workers began to dominate the labor pool. Migrant workers would arrive in the Santa Clara Valley for the harvest of apricots, pears and prunes between July and August. Often they lived in small bunkhouses on the orchard property or in nearby low-rent districts. The peaks and valleys of labor demand dovetailed with a migratory form of life and Mexican immigrants began to

¹⁴ Arbuckle, 163.

¹⁵ The history of San Jose annexation is chronicled in the 2009 *San Jose Modernism Historic Context Statement* by PAST Consultants, LLC.

¹⁶ Payne, 85.

Messina Orchard

Name of Property

Santa Clara County, CA
County and State

dominate the fruit production labor pool by the 1930s, joined by poor white farmers looking for work in the Great Depression.¹⁷

The vast Santa Clara Valley fruit packing and canning industries were dominated by Chinese labor until the arrival of Portuguese and Italian families. While the men labored in the fields, the women picked the fruit and worked as laborers in the packinghouses. Following the first wave of Italian immigration from northern Italy, a large Italian workforce started populating the valley from 1890 (718 residents) until World War I (1,822 residents). Because of the language barrier, only the lowest labor opportunities were first available to Italian immigrants, including the low-paying positions as pickers, sorters, packers and cannery workers. The Italians also entered the cannery labor force during this time period as well, and would contribute substantially to fruit growing, packing and processing in the coming decades. However, increasing numbers became fruit growers and pioneers, forming their own labor organizations and helping to continue in the development of the Valley's unprecedented fruit industry in the early 1900s.¹⁸

The Messina orchard illustrates the varied use of ethnic groups during its existence. Stefano and Marie Messina were Italian immigrants that arrived shortly after World War I to take advantage of a burgeoning fruit growing industry in Santa Clara Valley. Once established, they became regional participants in the Valley's vast horticultural industry, operating the Messina Orchard for two generations. Richard and Anita Messina continued the family business, with Richard Messina leading the Orchard's operation for a second generation of ownership until 1990. The Messina Orchard was a family operation with all children participating in the myriad daily tasks of running a significant horticultural operation. The Messina family hired and maintained relationships with regional workers who ran the day-to-day operations and migrant families from Mexico who worked during the harvest and returned to the same location every year due to a sense of loyalty to the Messina family.

Criterion C: Architecture

The Messina Orchard contains two historic, period-revival houses that served two generations of the Messina family: the 1935 Stefano and Marie Messina house and the 1949 Richard and Anita Messina house. The site also contains formal landscaping around each of the houses, two farm buildings, a water tank structure, original farm equipment and over four acres of orchard trees.

1935 Stefano and Marie Messina House, Garage and Formal Landscaping

The 1935 Stefano and Marie Messina house and garage are outstanding examples of Spanish Revival architecture and possess high artistic values. While the architect of the house and garage is unknown, family interview indicate that Stefano Messina dispatched his son, Richard Messina, to tour southern California for an appropriate style for the family home. Richard Messina viewed the Spanish Revival-style homes constructed by notable architect George Washington Smith in Santa Barbara, as well as significant Spanish Revival-style buildings in Los Angeles and Pasadena, such as Pasadena City Hall. Upon his return to the Messina Orchard, Stefano and

¹⁷ Payne, 100.

¹⁸ Basin Research Associates, *Cultural Resources Documentation Completed for the Capitol Light Rail Project*, 2000, 9.

Messina Orchard
Name of Property

Santa Clara County, CA
County and State

Richard Messina oversaw the construction of the 1935 Stefano and Marie Messina house in the Spanish Revival style.

As developed in California, the Spanish Revival style became popular following the 1915 Panama-California Exposition in San Diego and the designs of Bertram Goodhue for the California Quadrangle at the Exposition's entrance. The style sought to express and romanticize the California Missions and the state's Spanish and Mexican heritages, while designing buildings that harmonized with the state's Mediterranean climate. Buildings were constructed with irregular plans, often built around a courtyard, with complex rooflines, low-pitched roofs covered in clay-barrel tiles, arched porches and loggias, and irregular fenestration, often with arched openings. Materials were intended to resemble the Spanish missions and included thick walls with rounded corners finished with cement plaster, multi-light wood sash or casement windows often with decorative wrought iron grilles, rounded chimney tops, clay-barrel roofing tiles, and decorative details rendered in cement plaster or through the use of brick or ceramic tile inserts in building walls and gable ends.

The Stefano and Marie Messina house is in original condition and displays high artistic values that communicate its Spanish Revival-style. These character defining features include the irregular plan, with projecting gable ends and wings; arched front porch separated with decorative cement-plaster columns; side arches with smaller, matching columns leading to landscape areas; arched chimney with decorative tile and brick insets; multiple-light fenestration expressed in arched picture windows and the top sash of double-hung windows; textured-stucco exterior wall cladding and Spanish clay-barrel tiles.

The house's interior also displays hallmarks of the Spanish Revival style, including thick plastered walls, arched ceilings in the living room, formal rooms separated by arched openings flanked by cement plaster columns, and a tiled living room fireplace featuring ceramic tiles with romantic scenes depicting California missions set within a field of tiles in various earth tones.

While the 1935 Stefano and Marie Messina garage adjacent to the house is a modest design, it does display Spanish Revival stylistic features that match the house. These features include the use of cement plaster to create a look of thick walls with rounded corners; matching wood-sash windows; the garage door opening framed by cement plaster pilasters; and clay-barrel roof tiles.

The formal garden and lawns to the east of the house contribute to the site and were a source of pride for the successful horticulturist. Los Gatos landscape architect George Martin, who was known for his residential landscape designs and contracting operations in the Santa Clara Valley designed the formal garden to the north and east of the house.

A tinted concrete path centered on the house's front porch runs east of the house to a raised, circular foundation. The tinted concrete path continues east, on-axis from the circular fountain and terminates at the eastern property line on North Capitol Avenue. Two palm trees stand at the head of the path, symbolizing the farmer's success. To the north and south of these trees are a series of mature Redwood, Juniper, Cedar, Chinese Elm and smaller palm trees that serve to

Messina Orchard
Name of Property

Santa Clara County, CA
County and State

create a visual barrier between the property and the bustling arterial street to the east. Seasonal flowerbeds are set around the trees. The formal garden was a source of family pride, with the children often tending to the various plants. It remains in good condition today.

1949 Richard and Anita Messina House and Formal Landscaping

Constructed after World War II and at the beginning of the Mid-Century Modern movement in California, the Richard and Anita Messina house is a hybrid design, with Mediterranean Revival-style exterior massing and details, with Mid-Century Modern-style interior design elements. The house is in nearly original condition with a single window replacement (1960) in the arched opening on the north elevation and a second-story addition (1960) to the east elevation that matched the form, massing and materials of the original building.

The house was designed and constructed by Vincent Joseph (V.J.) Sunzeri (1903-1989), a regional contractor who is credited for constructing the Crescent Shopping Center in San Jose in the 1940s and the St. John Vianney Church (1954) in East San Jose, near the Messina Orchard. While these contributions are noteworthy, they don't elevate Vincent Sunzeri to a level of master architect or builder.

However, the Richard and Anita Messina house does possess high artistic values as a representative of the Mediterranean Revival style constructed in 1949. This style possesses similar design characteristics to the Spanish Revival style including asymmetrical roof massing, irregular plans, cement plaster wall cladding and clay-barrel tiles. The Richard and Anita Messina house's exterior contains many of these character-defining features, including the asymmetrical roof massing with roofs covered in clay-barrel tiles, stucco exterior wall cladding, a recessed upper story with corner loggias and decorative wrought iron railing.

The interior is in largely intact and possesses high artistic values in the use of stepped archways to delineate rooms, hardwood floors, a wrought-iron staircase, a masonry living room fireplace, Mid-Century Modern-style metal-casement windows and a family room with Mid-Century Modern-style metal ceiling beams and curved obscure glass.

Formal landscaping is located behind the walls to the north and east of the house, with lawns planted between the house and landscaping. Tree species consist of several Pine trees, Redwood trees, smaller palm trees, junipers, White Birch trees, Camphor trees, and Modesto Ash trees. Boxwood hedges run along the driveways and demarcate planted areas consisting of Jacaranda trees, flowering plum trees and seasonal flower beds. The formal landscaping north and east of the house is in good condition and continues to be a source of pride for the Messina family.

The Messina family houses, the 1935 Stefano and Marie Messina house and the 1949 Richard and Anita Messina house, are both representative examples of the Spanish Revival and Mediterranean Revival styles, respectively. Both houses are in largely original condition, with no alterations that would impact the individual historic integrity of the houses. Both houses also contain original interior character-defining features and original furnishings from both generations of the Messina family. The houses represent a window into two family generations

Messina Orchard
Name of Property

Santa Clara County, CA
County and State

that prospered in the Santa Clara Valley fruit industry and took pride in their surroundings, as evidenced by the outstanding original condition of both houses today.

9. Major Bibliographical References

Bibliography (Cite the books, articles, and other sources used in preparing this form.)

Arbuckle, Clyde. *Clyde Arbuckle's History of San Jose*. San Jose, CA: Smith & McKay Printing Company, 1985.

Basin Research Associates, Inc. and Ward Hill, M.A. *Cultural Resources Documentation for Completed for the Capitol Light Rail Project, Santa Clara Valley Transportation Authority, City of San Jose, Santa Clara County, California*, December 2000.

California Prune and Apricot Growers Association (Sunsweet). *California's Nature-Flavored Prunes and Apricots*. Paper-bound Book, 1917.

Chapman, Robin. *California Apricots: The Lost Orchards of Silicon Valley*. Charleston, SC: American Palate, 2013.

Henderson, Judi. "Messina Orchard Out, Homes Safe," *Continuity (Newsletter of Preservation Action Council of San Jose)*, Vol. 17, No. 1, Spring 2006.

Interviews with Marilyn Messina, Richard V. Messina's daughter, 1999, 2000, 2006, 2016, 2017.

Jacobson, Yvonne. *Passing Farms Enduring Values*. Los Altos, CA: William Kaufman, Inc., 1988.

National Register Bulletin 15: *How to Apply the National Register Criteria for Evaluation*. Washington D.C.: U.S. Department of the Interior, National Park Service, 1990 (Revised 1991, 1995, 1997, 1998).

National Register Bulletin 16A: *How to Complete the National Register of Historic Places Registration Form*. Washington D.C.: U.S. Department of the Interior, National Park Service, 1977 (Revised 1986, 1991, 1997).

PAST Consultants, LLC. *San Jose Modernism: Historic Context Statement*, 2009.

Payne, Stephen M. *Santa Clara County: Harvest of Change*. Northridge, CA: Windsor Publications, Inc., 1987.

"Professional Design Lasts a Lifetime," *Pacific Sun*, April 19, 1961.

Messina Orchard
Name of Property

Santa Clara County, CA
County and State

“Ranch – Home – Garden,” *San Jose Mercury News*, October 14, 1951.

“R.V. Messina – New Developments, Sound Experience,” *Clara-Benito Farm Journal*,
October 1952.

Urban Programmers. *Mitigation Documentation Required by City of San Jose Planning
Department PDC 005-060, Conditions of Approval, Cultural Resource 5.1, Completed for
the Messina Fruit Ranch*, June 30, 2006.

Previous documentation on file (NPS):

- preliminary determination of individual listing (36 CFR 67) has been requested
- previously listed in the National Register
- previously determined eligible by the National Register
- designated a National Historic Landmark
- recorded by Historic American Buildings Survey # _____
- recorded by Historic American Engineering Record # _____
- recorded by Historic American Landscape Survey # _____

Primary location of additional data:

- State Historic Preservation Office
- Other State agency
- Federal agency
- Local government
- University
- Other

Name of repository: History San Jose

Historic Resources Survey Number (if assigned): _____

10. Geographical Data

Acreage of Property 4.96 acres

Latitude/Longitude Coordinates

Datum if other than WGS84: _____

(enter coordinates to 6 decimal places)

1. Latitude: 37.377190

Longitude: -121.850465

Verbal Boundary Description (Describe the boundaries of the property.)

The Messina Orchard is located on the southwest corner of N. Capitol Avenue and Mabury Road, in San Jose, Santa Clara County, California. The parcel consists of APN 254-06-049,

Messina Orchard
Name of Property

Santa Clara County, CA
County and State

a 4.96-acre rectangular parcel that extends southwest from the above roadway intersection and containing the two residences, 681 N. Capitol Avenue and 721 N. Capitol Avenue.

Boundary Justification (Explain why the boundaries were selected.)

The boundary includes the remaining parcel belonging to the Messina Orchard and includes a residence and garage, constructed circa-1935; a second family home, constructed circa-1949, formal landscaping in front of both residences, two equipment barns, a water tank and an orchard laid out between the two homes.

11. Form Prepared By

name/title: Seth A. Bergstein, Principal
organization: PAST Consultants, LLC
street & number: P.O. Box 721
city or town: Pacific Grove state: CA zip code: 93940
e-mail seth@pastconsultants.com telephone: (415) 515-6224 date: October 2017

Additional Documentation

Submit the following items with the completed form:

- **Maps:** A **USGS map** or equivalent (7.5 or 15 minute series) indicating the property's location.
- **Sketch map** for historic districts and properties having large acreage or numerous resources. Key all photographs to this map.
- **Additional items:** (Check with the SHPO, TPO, or FPO for any additional items.)

Photographs SUBMITTED AT 72 DPI

Submit clear and descriptive photographs. The size of each image must be 1600x1200 pixels (minimum), 3000x2000 preferred, at 300 ppi (pixels per inch) or larger. Key all photographs to the sketch map. Each photograph must be numbered and that number must correspond to the photograph number on the photo log. For simplicity, the name of the photographer, photo date, etc. may be listed once on the photograph log and doesn't need to be labeled on every photograph.

Photo Log

Name of Property: Messina Orchard
City or Vicinity: San Jose
County: Santa Clara
State: California

Photographer: Seth Bergstein
Date Photographed: April 2017

Messina Orchard
Name of Property

Santa Clara County, CA
County and State

Description of Photograph(s) and number, include description of view indicating direction of camera:

- | | |
|----------|--|
| 1 of 20 | Circular drive and Stefano and Marie Messina house looking northwest |
| 2 of 20 | Formal landscaping and Stefano and Marie Messina house looking west |
| 3 of 20 | Formal landscaping looking east from Stefano and Marie Messina house porch |
| 4 of 20 | East elevation of Stefano and Marie Messina house looking west |
| 5 of 20 | Northeast building corner of Stefano and Marie Messina house looking southwest |
| 6 of 20 | South elevation of Stefano and Marie Messina house looking northeast |
| 7 of 20 | Stefano and Marie Messina House dining room interior |
| 8 of 20 | Stefano and Marie Messina House living room interior |
| 9 of 20 | Stefano and Marie Messina House living room fireplace |
| 10 of 20 | Stefano and Marie Messina House bathroom interior detail |
| 11 of 20 | East elevation of Stefano and Marie Messina garage looking west |
| 12 of 20 | North elevation of Richard and Anita Messina house looking southwest |
| 13 of 20 | East elevation of Richard and Anita Messina house looking west |
| 14 of 20 | Richard and Anita Messina house kitchen interior |
| 15 of 20 | Richard and Anita Messina house staircase interior detail |
| 16 of 20 | Richard and Anita Messina house family room interior |
| 17 of 20 | East and south elevations of Multi-bay Equipment Shed looking northwest |

Messina Orchard
Name of Property

Santa Clara County, CA
County and State

- | | |
|----------|---|
| 18 of 20 | South elevation of Single-bay Equipment Shed looking north |
| 19 of 20 | Water tank looking southwest |
| 20 of 20 | Orchard view looking southwest toward Stefano and Marie Messina house |

Messina Orchard
Name of Property

Santa Clara County, CA
County and State

Photo Location Key

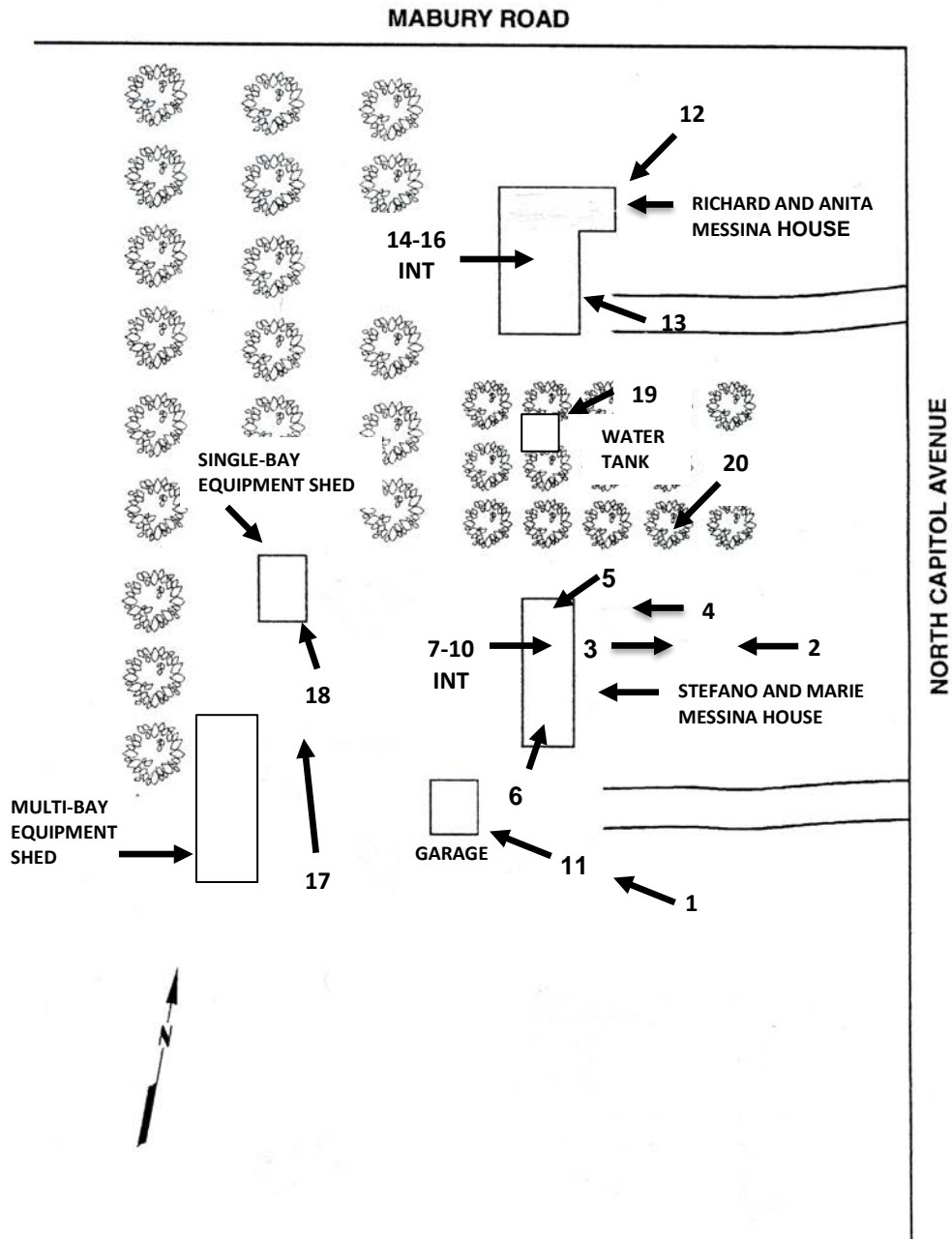

Messina Orchard
Name of Property

Santa Clara County, CA
County and State

Index of Figures

- Figure 1 of 4 Location Map (*Courtesy: Google Earth, 2017*)
- Figure 2 of 4 Stefano and Richard Messina in the orchard, circa 1940 (*Courtesy: Marilyn Messina, Messina Family Archives*)
- Figure 3 of 4 Richard and Anita Messina in front of the circa-1935 Spanish Revival House in the 1940s (*Courtesy: Marilyn Messina, Messina Family Archives*)
- Figure 4 of 4 Richard V. Messina driving the tractor, with workers spraying the orchard trees, 1952 (*Courtesy: Marilyn Messina, Messina Family Archives*)

Paperwork Reduction Act Statement: This information is being collected for applications to the National Register of Historic Places to nominate properties for listing or determine eligibility for listing, to list properties, and to amend existing listings. Response to this request is required to obtain a benefit in accordance with the National Historic Preservation Act, as amended (16 U.S.C.460 et seq.).

Estimated Burden Statement: Public reporting burden for this form is estimated to average 100 hours per response including time for reviewing instructions, gathering and maintaining data, and completing and reviewing the form. Direct comments regarding this burden estimate or any aspect of this form to the Office of Planning and Performance Management, U.S. Dept. of the Interior, 1849 C. Street, NW, Washington, DC.

Messina Orchard
Name of Property

Santa Clara County, CA
County and State

Figure 1. Location Map (Source: Google Earth, 2017)

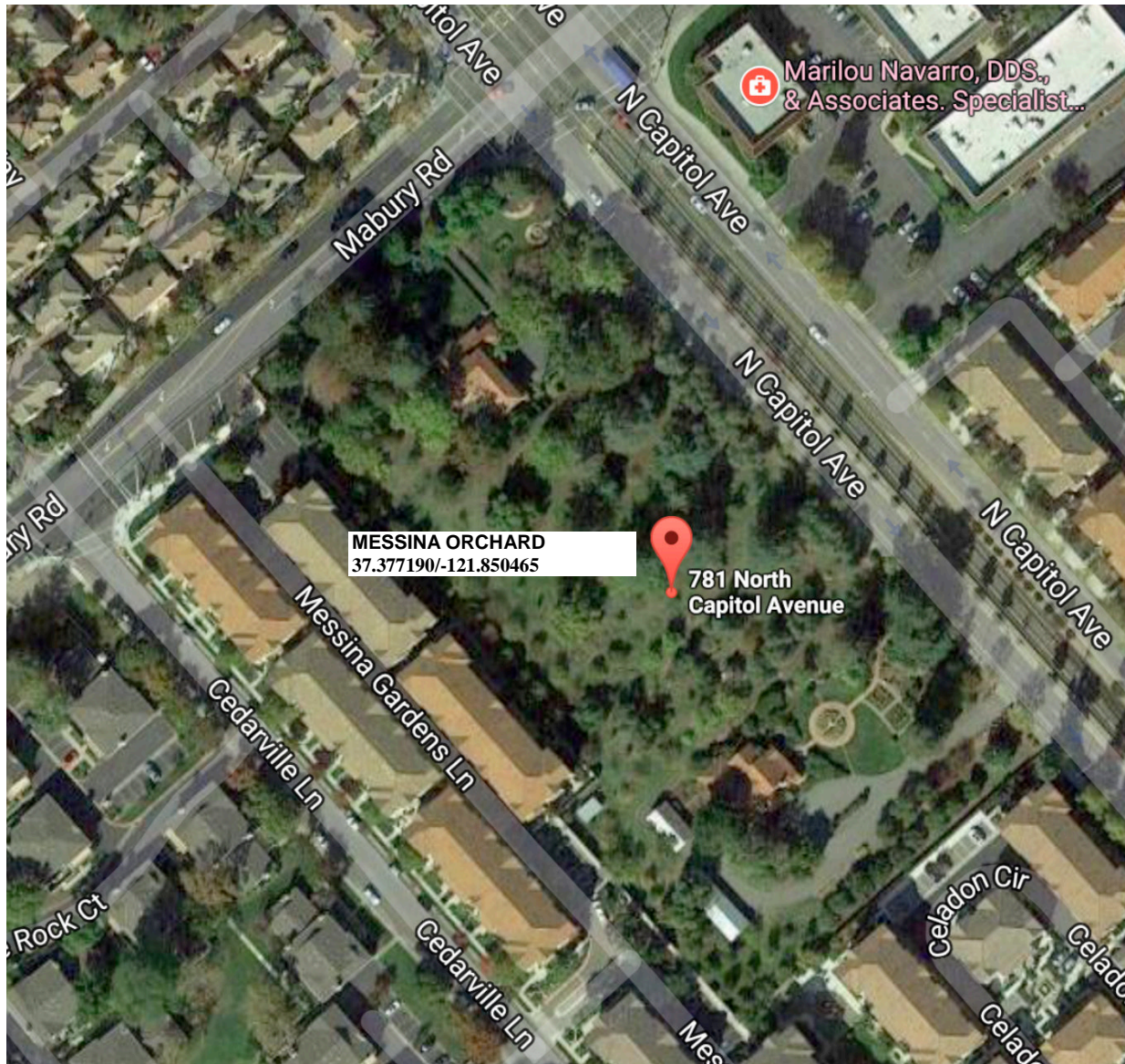

Messina Orchard
Name of Property

Santa Clara County, CA
County and State

Figure 2. Stefano and Richard Messina in the orchard, circa 1940



Messina Orchard
Name of Property

Santa Clara County, CA
County and State

Figure 3. Richard and Anita Messina in front of the circa-1935 Spanish Revival House in the 1940s



Messina Orchard
Name of Property

Santa Clara County, CA
County and State

Figure 4. Richard V. Messina driving the tractor, with workers spraying the orchard trees, 1952



































PRIVATE PROPERTY NO TRESPASSING





MESSINA
ORCHARDS
1908





UNITED STATES DEPARTMENT OF THE INTERIOR
NATIONAL PARK SERVICE

NATIONAL REGISTER OF HISTORIC PLACES
EVALUATION/RETURN SHEET

Requested Action: Nomination

Property Name: Messina Orchard

Multiple Name:

State & County: CALIFORNIA, Santa Clara

Date Received: 2/23/2018 Date of Pending List: 3/14/2018 Date of 16th Day: 3/29/2018 Date of 45th Day: 4/9/2018 Date of Weekly List:

Reference number: SG100002288

Nominator: State

Reason For Review:

Accept Return Reject 4/9/2018 Date

Abstract/Summary Comments: The Messina Orchard is locally significant under National Register Criteria A and C in the areas of Agriculture and Architecture. With the post-WWII suburban expansion and development of much of the once rural Santa Clara Valley, the Messina Orchard is a rare extant illustration of the region's once dominant fruit-growing legacy. Although reduced from a 40-acre working orchard to a 4-acre urban parcel, the property's fanciful Spanish Revival and Mediterranean Revival-inspired residences, fine landscaped gardens, and remnant agricultural infrastructure (sheds and orchard trees) spotlight the status of the Messina family operation as a prominent reflection of the region's important twentieth century agricultural development.

Recommendation/ Criteria: Accept NR Criteria A and C.

Reviewer: Paul Lusignan

Discipline: Historian

Telephone: (202)354-2229

Date: 4/9/2018

DOCUMENTATION: see attached comments : No see attached SLR : No

If a nomination is returned to the nomination authority, the nomination is no longer under consideration by the National Park Service.

Messina Orchard
San Jose, Santa Clara County
Staff Report

The Messina Orchard consists of a 4.96 acre, rectangular parcel of land located southeast of the intersection of North Capitol Avenue and Mabury Road, in San Jose, California. The parcel contains two houses, the 1935 Stefano and Marie Messina house, a richly ornamented Spanish Revival-style residence with a matching garage; and the 1949 Richard and Anita Messina house, a well-preserved Mediterranean Revival-style residence. The 1935 house has extensive and formal landscape plantings east of the residence, including a circular pathway, fountain and paired palm trees. The 1949 house also has formal landscaping and a masonry wall at the northeast corner of the site, at the intersection of North Capitol Avenue and Mabury Road. In addition, the property contains two equipment sheds that shelter original farm equipment, a water tank, and numerous orchard trees.

The Messina Orchard is eligible for the National Register at the local level of significance under Criterion A, in the area of Agriculture, for its association with the agricultural development of the Santa Clara Valley. As wheat production declined in California in the early 1880s, the Santa Clara Valley turned to fruit production. The eventual demand created by eastern markets and two world wars would provide the market for the meteoric development of the Santa Clara Valley into the nation's leading producer of fruits and nuts from the end of the 19th Century until the close of World War II. Even before World War I, northern Europeans enjoyed canned fruit from one of the numerous San Jose canneries. The Messina Orchard employed up to 25 persons in the cultivation and processing of fruit, contributing to the vast fruit production that earned the Santa Clara Valley the name, "Valley of Heart's Delight."

The property is also eligible for the National Register at the local level under Criterion C in the area of Architecture, for its two intact, period revival single-family residences, formal landscaping, extant farm buildings and orchard trees. The property embodies the characteristics of a fruit orchard operating in the Santa Clara valley in the early to mid-twentieth century. The two family houses on the property represent multiple generations of the Messina family living on, and farming the orchard. The Messina Orchard with its two residences is a rare and unique agricultural property in highly urbanized San Jose. The period of significance begins in 1925, the construction date of the two extent farm buildings, and ends in 1960, the year when fruit production had declined substantially in the Santa Clara Valley, as post-World War II industrial growth and suburban expansion replaced the orchards with roadways, subdivisions and industrial parks.

The Messina Orchard is nominated to the National Register by its owner, Marilyn Messina. Preservation Action Council of San Jose sent a letter of support for the nomination. Staff supports the nomination as written and recommends the State Historical Resources Commission determine the Messina Orchard eligible under National Register Criteria A and C at the local level of significance with a period of significance from 1925 to 1960.

Jay Correia
October 6, 2017

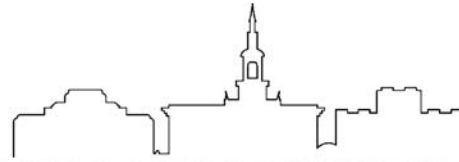

PRESERVATION ACTION COUNCIL OF SAN JOSE

Dedicated to Preserving San Jose's Architectural Heritage

September 28, 2017

Julianne Polanco, State Historic Preservation Officer
Office of Historic Preservation
Department of Parks and Recreation
ATTN: Registration Unit
1725 23rd Street, Suite 100
Sacramento, CA 95816-7100

Re: Messina Orchard National Register of Historic Places Nomination

Dear Julianne:

The Preservation Action Council of San Jose (PAC-SJ) was founded in 1990 and is dedicated to preserving and promoting the continued use of historically significant resources in San Jose and preserving San Jose's architectural heritage.

We support the National Register nomination of the Messina Orchard and urge the State Historical Resources Commission to approve the nomination.

At least as far back as 1999 the property was identified as being eligible for listing on the California Register and the National Register of Historic Places as a rare surviving example of an operating orchard. A historic report done at that time also indicated the Spanish Colonial Revival style house was eligible on its own merit for the California Register.

The Messina Orchard is a wonderful living example of the history that helped make this area the Valley of Heart's Delight and we look forward to its listing on the National Register.

Thank you for the opportunity to comment in support of the National Register nomination of the Messina Orchard.

Sincerely,

Brian K. Grayson
Executive Director

c: Jay.Correia@parks.ca.gov



**DEPARTMENT OF PARKS AND RECREATION
OFFICE OF HISTORIC PRESERVATION**

Lisa Ann L. Mangat, Director

Julianne Polanco, State Historic Preservation Officer
1725 23rd Street, Suite 100, Sacramento, CA 95816-7100
Telephone: (916) 445-7000 FAX: (916) 445-7053
calshpo.ohp@parks.ca.gov www.ohp.parks.ca.gov



February 22, 2017

J. Paul Loether
Attention: Paul Lusignan
National Register of Historic Places
National Park Service 2280
1201 I (Eye) Street, NW
Washington, DC 20005

Subject: **Messina Orchard Historic District National Register of Historic Places
Nomination**

Dear Mr. Loether:

The enclosed disc contains the true and correct copy of the nomination for Messina Orchard Historic District to the National Register of Historic Places. On October 27, 2017, at its regular quarterly meeting, held in Sacramento, the California State Historical Resources Commission (Commission) unanimously found Messina Orchard eligible for the National Register.

Under Criterion A, the Commission found Messina Orchard eligible in the area of Agriculture, for its association with the agricultural development of the Santa Clara Valley. The property is also eligible for the National Register at the local level under Criterion C in the area of Architecture, for its two intact, period revival single-family residences, formal landscaping, extant farm buildings and orchard trees.

Marilyn Messina, the owner of Messina Orchard, nominated the property to the National Register. In a letter dated August 28, 2017, the Office of Historic Preservation notified the City of San Jose, a Certified Local Government, of the Commission's pending hearing of the nomination. The City of San Jose did not comment. If you have questions please contact Jay Correia at 916-445-7008 or jay.correia@parks.ca.gov.

Sincerely,

Julianne Polanco
State Historic Preservation Officer

Enclosures