



United States Department of the Interior
National Park Service

National Register of Historic Places
Registration Form

This form is for use in nominating or requesting determinations for individual properties and districts. See instructions in *How to Complete the National Register of Historic Places Registration Form* (National Register Bulletin 16A). Complete each item by marking "x" in the appropriate box or by entering the information requested. If an item does not apply to the property being documented, enter "N/A" for "not applicable." For functions, architectural classification, materials, and areas of significance, enter only categories and subcategories from the instructions. Place additional entries and narrative items on continuation sheets (NPS Form 10-900a). Use a typewriter, word processor, or computer, to complete all items.

1. Name of Property

historic name Dunleith and Dubuque Bridge
other names/site number Whitewater Creek Bridge; Bergfeld Recreation Area Bridge

2. Location

street & number 7600 Chavenelle Drive not for publication n/a
city or town Dubuque vicinity n/a
state Iowa code IA county Dubuque code 061 zip code 52001

3. State/Federal Agency Certification

As the designated authority under the National Historic Preservation Act, as amended, I hereby certify that this nomination request for determination of eligibility meets the documentation standards for registering properties in the National Register of Historic Places and meets the procedural and professional requirements set forth in 36 CFR Part 60. In my opinion, the property meets does not meet the National Register criteria. I recommend that this property be considered significant nationally statewide locally. (See continuation sheet for additional comments.)

[Signature] Signature of certifying official 7/23/2013 date

STATE HISTORICAL SOCIETY OF IOWA

State or Federal agency or bureau

In my opinion, the property meets does not meet the National Register criteria. (See continuation sheet for additional comments.)

Signature of commenting or other official _____ date _____

State or Federal agency or bureau

4. National Park Service Certification

I hereby certify that the property is:
 entered in the National Register [Signature] Signature of Keeper 9/11/2013 date of action
 See continuation sheet
 determined eligible for the National Register
 See continuation sheet
 determined not eligible for the National Register
 removed from the National Register
 other (explain): _____

5. Classification

Ownership of Property
(Check as many boxes as apply)

private _____
public - local x
public - state _____
public - federal _____

Category of Property
(Check only one box)

building(s) _____
district _____
site _____
structure x
object _____

Number of Resources within Property
(Do not include previously listed resources in the count)

	Contributing	Noncontributing
buildings	<u> 0 </u>	<u> 0 </u>
sites	<u> 0 </u>	<u> 0 </u>
structures	<u> 1 </u>	<u> 0 </u>
objects	<u> 0 </u>	<u> 0 </u>
Total	<u> 1 </u>	<u> 0 </u>

Name of related multiple property listing
(Enter "N/A" if property is not part of a multiple property listing)
 Highway Bridges of Iowa

Number of contributing resources previously listed in the National Register
 1

6. Function or Use

Historic Functions
(Enter categories from instructions)

 TRANSPORTATION: rail-related
 TRANSPORTATION: road-related

Current Functions
(Enter categories from instructions)

 TRANSPORTATION: pedestrian-related

7. Description

Architectural Classification
(Enter categories from instructions)

 PRATT THROUGH TRUSS

Materials
(Enter categories from instructions)

foundation CONCRETE
walls n/a
roof n/a
other METAL: cast and wrought iron

Narrative Description
(Describe the historic and current condition of the property on one or more continuation sheets.)

8. Statement of Significance

Applicable National Register Criteria

(Mark "x" in one or more boxes for the criteria qualifying the property for National Register listing)

- A Property is associated with events that have made a significant contribution to the broad patterns of our history.
- B Property is associated with the lives of persons significant in our past.
- C Property embodies the distinctive characteristics of a type, period, or method of construction or represents the work of a master, or possesses high artistic values, or represents a significant and distinguishable entity whose components lack individual distinction.
- D Property has yielded, or is likely to yield information important in prehistory or history.

Criteria Considerations

(Mark "x" in all the boxes that apply)

- A owned by a religious institution or used for religious purposes.
- B removed from its original location.
- C a birthplace or a grave.
- D a cemetery.
- E a reconstructed building, object, or structure.
- F a commemorative property.
- G less than 50 years of age or achieved significance within the past 50 years.

Areas of Significance

(Enter categories from instructions)

ENGINEERING

Period of Significance

1872

Significant Dates

1872

Significant Person

n/a

Cultural Affiliation

Architect / Builder

Keystone Bridge Company

Narrative Statement of Significance

(Explain the significance of the property on one or more continuation sheets.)

9. Major Bibliographical References

Bibliography

(Cite the books, articles, and other sources used in preparing this form on one or more continuation sheets.)

Previous documentation on file (NPS):

- preliminary determination of individual listing (36 CFR 67) has been requested
- previously listed in the National Register
- previously determined eligible by the National Register
- designated a National Historic Landmark
- recorded by Historic American Buildings Survey
- recorded by Historic American Engineering Record

Primary location of additional data:

- State Historic Preservation Office
- other state agency
- Federal agency
- local government
- university
- other _____

10. Geographical Data

Acreage of Property less than one**UTM References**

(Place additional UTM references on a continuation sheet)

<u>15</u>	<u>682920</u>	<u>4706005</u>
zone	easting	northing

Verbal Boundary Description

(Describe the boundaries of the property on continuation sheet)

Boundary Justification

(Explain why the boundaries were selected on continuation sheet)

11. Form Prepared By

name/title Clayton B. Fraser, Principal (email: cbfraser@aol.com)organization FRASERdesign date 28 August 2012street & number 5700 Jackdaw Drive telephone 970.669.7969city or town Loveland state Colorado zip code 80537

Additional Documentation

submit the following items with the completed form

Continuation Sheets**Maps**

A USGS map (7½ or 15 minute series) indicating the property's location

A Sketch map for historic districts and properties having large acreage or numerous resources

Photographs

Representative photographs of the property

Additional items

(Check with the SHPO or FPO for any additional items)

Property Owner

name/title City of Dubuquestreet & number 50 West 13th Street telephone 563.589.4100city or town Dubuque state Iowa zip code 52001

Paperwork Reduction Act Statement: This information is being collected for applications to the National Register of Historic Places to nominate properties for listing or determine eligibility for listing, to list properties, and to amend existing listings. Response to this request is required to obtain a benefit in accordance with the National Historic Preservation Act, as amended (16 U.S.C. 470 et seq.).

Estimated Burden Statement: Public reporting burden for this form is estimated to average 18.1 hours per response including time for reviewing instructions, gathering and maintaining data, and completing and reviewing the form. Direct comments regarding this burden estimate or any aspect of this form to the Chief, Administrative Services Division, National Park Service, P.O. Box 37127, Washington, DC 20013-7127; and the Office of Management and Budget, Paperwork Reductions Projects (1024-0018), Washington, DC 20503.

United States Department of the Interior
National Park ServiceNational Register of Historic Places
Continuation Sheet

section number 7 page 1

DUNLEITH AND DUBUQUE BRIDGE Dubuque County, Iowa

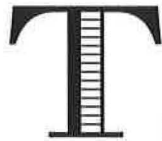

SUMMARY

The bridge discussed in this nomination is one of seven iron trusses that had originally comprised an approach structure for the Dunleith and Dubuque Bridge over the Mississippi River [Fig. 1]. Having been moved twice since its original construction, it is now situated in the Bergfeld Recreation Area in Dubuque. Already individually listed in the National Register after its first move to a county road [Fig. 2], the truss is being nominated here in its more recent location in the Bergfeld Recreation Area. The recreation area is a small, recently developed pocket park that straddles Chavenelle Road within a sprawling industrial park in the city's western suburb [Fig. 3]. Shaped like a backwards "L", the park encloses a linear 1.9-mile bike/hike trail, which adjoins a 0.8-mile walking loop at the park's western extremity. The loop is paved and essentially flat, forming a handicap-accessible venue as it circles man-made Bergfeld Pond. The bridge carries the loop trail at the pond's inlet at its northern tip, immediately south of Chavenelle Road. The Bergfeld Recreation Area is surrounded by large, modern industrial buildings, which are set in even larger tracts of land characterized by broad parking lots and suburban landscaping. The park itself is similarly landscaped, with grassed lawn and interspersed native plant areas. A small grassed esplanade, with flagpoles, benches, ramps, retaining walls, a restroom structure and a parking area, is situated immediately east of the bridge. The bridge is comprised of a single iron truss, supported on its two ends by reinforced concrete abutments, which are seated in small beds of crushed stone riprap [Fig. 4]. The structure is an eight-panel Pratt through truss, with a 93'-8" span and a 19'-6" width. Its members are cast and wrought iron; its connections at its upper and lower chords are pinned and bolted. The abutments are new, and the truss has been recently restored. The structure is thus in excellent physical condition.



NARRATIVE DESCRIPTION

As a single-span bridge, supported by concrete abutments and carrying pedestrian traffic over a pond in a grassy city park, the Dunleith and Dubuque Bridge is presently about as far as it can be—while remaining in Dubuque County—from its original circumstances. It was fabricated and erected by the Keystone Bridge Company in 1871-1872 as a railroad structure, moved ca. 1890 to a Dubuque County road, and moved again to its present position in this Dubuque city park in 2010. The iron truss superstructure remains as originally fabricated. What has been lost physically during these relocations is much of the original floor system. The wrought iron floor beams remain in place, held by their original straps, but the original rails, ties and wooden deck were removed when it was converted to vehicular use in the late 19th century. And since the more recent move from the county road to the city park, the wooden vehicular deck has been discarded. Also gone are the steel lattice guardrails installed soon after the truss was moved to the county road. At the time of this writing, the truss has been moved into place, but the timber pedestrian deck and new guardrails have yet to be installed. This is scheduled to occur in late 2012. The truss itself remains in a condition that is close to original, however. The ironwork is virtually all intact and, since its recent restoration, is in a pristine state of preservation.

United States Department of the Interior
National Park Service

National Register of Historic Places
Continuation Sheet

section number 7 page 2

DUNLEITH AND DUBUQUE BRIDGE Dubuque County, Iowa

The span is configured as a pin-connected Pratt through truss, with inclined end posts and riveted, wrought iron Keystone-patent columns (see Appendix for HAER drawings). Like all Pratt trusses, it features upper chords and verticals that act in compression (i.e., with the load pushing into the ends) and lower chords and diagonals that act in tension (the load pulling at the ends). The upper chords are comprised of two back-to-back wrought iron channels, each 9 inches deep by 2½ inches wide, spaced to a 14-inch overall width, with a quarter-inch-thick cover plate and half-inch-thick lacing below. The lower chords on the outer panels are comprised of two 1¾-inch-square eyebars with looped, forged ends; lower chords in the four inner panels are made up of four similar eyebars. The main verticals are riveted Keystone-patent octagonal columns, each comprised of four W-shaped iron sections with rivets through their flanges and spacers inbetween.

These are connected with the upper chords by means of cast iron joint boxes and with the lower by means of cast iron foot boxes through which the lower-chord pins pass. The verticals at the truss hips are two forged 1¼-inch-square eyebars. The diagonals are also looped eyebars, each 1¾ inches square; the lateral bracing features round eyerods with adjustable turnbuckles. The struts are slotted cast iron I-beams, each 7½ inches or 8¾ inches deep. The floor beams are wrought iron I-beams, each 14¾ inches deep with a 4¾-inch-wide flange width. The end posts are octagonal Keystone columns, joined to the upper chords at the truss's hips by cast iron joint boxes. Massive cast iron bearing shoes rest on cast iron pedestals at the truss's four corners. The truss features decorative elements at its cast iron portal braces and portal struts.

It is this configuration that distinguishes the structure as a characteristic Keystone Bridge Company truss, fabricated from patents obtained by Jacob Linville and John Piper and first developed by the company in 1862. The most distinctive elements of the truss are its built-up octagonal columns, made up of riveted wrought iron sections joined to the upper and lower chords by means of cast iron boxes. These columns are fabricated with the sections wider at mid-span than at the ends, an innovative structural feature for the mid-19th century. The truss features several other features touted by Keystone in the company's 1875 catalog, features such as wrought iron upper chords, weldless chord links, adjustable counters, suspended cross-girders and improved safety floors. The catalog discusses in detail Keystone's design philosophies. About tension members, it states:

The various methods employed to produce eyebars of uniform strength had invariably proved unsuccessful, until Linville & Piper, in 1862, devised and demonstrated the success of their method of upsetting the ends. Welded bars were found to be reliable only for seventy-five per cent of the sectional area of the bar. The usual process of upsetting by forging was unsuccessful, since frequent reheatings reduced the section at the junction with the heads. By the Linville & Piper patent, eyebars are made to shape under pressure in moulds, into which the heated iron is forced under immense pressure. The head being slightly thickened—say twenty per cent—the area of the connecting pin should be greater than the area of the bar, and the semi-cylindrical surface-bearing should be equal to the sectional area of the bar. The sectional area outside of the pin-hole should exceed by twenty-five per cent the area of the body of the bar. By increasing the thickness of the heads the diameter of the eye can, generally, be maintained at about one-half

United States Department of the Interior
National Park Service

National Register of Historic Places
Continuation Sheet

section number 7 page 3

DUNLEITH AND DUBUQUE BRIDGE Dubuque County, Iowa

the width of the bar. The bearing-surface for the pin, as well as the resisting area at the eye, is more advantageously increased by thickening, than by increasing the width of the heads.¹

And about compression members:

The cylindrical form of strut or column is best adapted, theoretically, to resist compressive force, applied vertically, in the direction of its axis. A hollow cylinder, of uniform thickness, is the only form of strut offering uniform resistance to flexure, transversely, in every direction and affording the highest resistance with the least expenditure of material. The great cost of lap or butt welded tubes led to the invention, by Messrs. Linville & Piper, of hollow posts, made by uniting together specially-rolled sections. The addition of flanges, convenient in securing the edges, does not materially increase the lateral stiffness in the direction of the diameter taken midway between the flanges. The material in the flanges would therefore be more economically disposed by increasing the diameter or thickness of the shell. This company usually employs the octagonal form—in order to preserve greater symmetry in the proportions of the columns—swelled towards the centre. By increasing the diameter at the center, and separating the sections, greater resistance to flexure is obtained, and the openings between the sections allow the interior of the column to be repainted.²

The Keystone Bridge Company was not the only bridge fabricator to employ such built-up iron columns for the compression members of its trusses. The King Bridge Company and the Wrought Iron Bridge Company, two major bridge manufacturers from Ohio, fabricated similar cylindrical and hexagonal built-up sections for the arches in their vehicular bowstring arch-trusses. Both of these companies were tremendously prolific in Iowa in the 1860s and 1870s, erecting numerous iron spans on county roads throughout the state. By the early 1880s this method of construction had been rendered obsolete, however, and ceased to be used on railroad and vehicular trusses. Through subsequent attrition, only a small number of these structures remains in Iowa.³ Because it has been moved from its original location, the Dunleith and Dubuque Bridge has lost much of its integrity of location, setting, feeling and association. But with most of its original fabric in place, it presently displays notable integrity of design, materials and workmanship. As one of the last standing examples in the state of early all-iron bridge technology, the Dunleith and Dubuque Bridge is distinguished as an important remnant of the material culture of Iowa.

¹Keystone Bridge Company, *Descriptive Catalogue of Wrought-Iron Bridges* (Philadelphia: Allen, Lance & Stout, 1875), 25.

²*Ibid.*, 25.

³One of the best-known of these is the Freeport Bowstring Arch Bridge (1879; NR 1984) in Winneshiek County. This span was moved from its original location on a county road in 1987 and re-erected over new abutments in a Decorah city park under circumstances similar to those of the Dunleith and Dubuque Bridge.

United States Department of the Interior
National Park Service

National Register of Historic Places
Continuation Sheet

section number 8 page 4

DUNLEITH AND DUBUQUE BRIDGE

Dubuque County, Iowa



SUMMARY

As one of the first bridges to span the Mississippi River, constructed at a time in which railroads were opening the West to settlement, the Dunleith and Dubuque Bridge was one of Iowa's—and the country's—most historically significant early spans. Andrew Carnegie grandly characterized the structure as “the most important railway bridge that had been built up to that time.”⁴ And no less a personage than Abraham Lincoln termed Mississippi River bridges a part of the nation's manifest destiny toward western development. Dubuque benefitted tremendously from the commerce attracted by the bridge, functioning as a regional nexus for trade throughout the late 19th century. As trade increased, though, so did the size of the locomotives and trains crossing the bridge, and it eventually became structurally obsolete. To address this, the Dunleith and Dubuque Bridge was dismantled in pieces late in the century. This span, erected in 1871-1872 as part of a seven-span approach structure west of the main bridge, was removed and sold to Dubuque County around 1890 for use as a county-road span. Detached from the context of the original, multiple-span structure, this single span's role on a rural county road was far less momentous in its historical contribution. But as one of the last two remaining fragments of the original railroad structure in Iowa, it enjoyed a degree of significance, despite its change of setting.

The bridge's more recent move from the county road to a Dubuque city park further removes it from its role as a transportation-related resource. But it is still technologically significant as one of the last remaining examples in America of cast/wrought iron truss construction. Built by one of the country's premier bridge fabricators of the 1860s and 1870s, it features the Keystone Bridge Company's patented wrought iron columns and ornamental cast iron connector blocks. One of Iowa's oldest surviving bridge spans, it is distinguished as a rare survivor from the country's earliest period of all-iron bridge engineering and construction. As such, the Dunleith and Dubuque Bridge is eligible for listing in the National Register under Criterion C for its state-level engineering significance.

Note: This truss span from the Dunleith and Dubuque Bridge was individually listed in the National Register in 1998 as the White Water Creek Bridge, named for the county road crossing in rural Dubuque County at which it was re-erected. The truss has since been moved again to its present location in a Dubuque city park and restored as a means to historic preservation. This new nomination is intended to update the 1998 document and address the ramifications of this most recent relocation under Criteria Consideration B.

⁴Andrew Carnegie, *Autobiography of Andrew Carnegie* (Cambridge, Mass.: Riverside Press, 1920), 123.

United States Department of the Interior
National Park Service

National Register of Historic Places
Continuation Sheet

section number 8 page 5

DUNLEITH AND DUBUQUE BRIDGE Dubuque County, Iowa

ELABORATION

From the start, Dubuque's fortunes have been tied inexorably to the Mississippi River.⁵ Founded by lead miners in 1833, the settlement soon became a stopping point for boats that plied the river trade. But Dubuque almost immediately concerned itself with east-west travel across the river as well. One of the first commercial businesses established in the fledgling town was a ferry operation on the river, established by General George W. Jones. Later another ferry crossed the Mississippi between Dubuque and Dunleith (now East Dubuque), Illinois, hauling freight, livestock and passengers across the river. In 1850 Augustus and Charles Gregoire operated the city's first steam ferry. Timothy Fanning ran a second steam line, docking the boat behind his saloon near present-day First and Iowa Streets. These wagon ferries contributed greatly to the commercial prosperity of Dubuque and influenced the town's physical development through the location of their terminals. But their effect on Dubuque transportation and commerce paled in comparison with the impact of the railroads.

⁵Of the three great Midwestern rivers—the Missouri, the Mississippi and the Ohio—the Mississippi is by far the largest, receiving much of its flow from the other two. Combined, these three watercourses contribute almost two-thirds of the flow through the lower Mississippi, but more than fifty navigable tributaries in all drain into the Mississippi along its twisting course, totaling more than 14,000 miles of navigable waterways that border or traverse 27 states. In its upper reaches through Minnesota, Iowa and northern Missouri, the Mississippi flows through a relatively stable channel with a gentle rate of descent. At the mouth of the Missouri, just above St. Louis, the Mississippi changed character in the 19th century, resembling more the raucous tributary than its own calm upper reaches. "They are rivers of very different character," stated bridge engineer George Morison in 1894, "the Mississippi being a quiet stream of comparatively stable character and the Missouri a silt-bearer of the first magnitude. The Missouri gives the character to the united river below the junction. It is a silt-bearer subject to floods, but not to as violent floods as those in the Ohio." Between the Missouri and the mouth of the Ohio at Cairo, Illinois, the Mississippi became deeper and more constricted, with a mean width of some three-quarters of a mile. It also gained velocity and a considerable amount of force with the increased flow of water. Here the Mississippi became, as George Conclin observed in 1852, "a furious and boiling current, a turbid and dangerous mass of sweeping waters, jagged and dilapidated shores, and, wherever its waters have receded, deposits of mud—a wild, whirling river, never navigated, except with great danger."

The dividing line between the upper and lower Mississippi was generally believed to be the mouth of the Ohio River, the major tributary that almost doubled the flow of the parent river. For over 1,000 miles below Cairo, the river meandered with a barely perceptible current through a level flood plain from 50 to 100 miles wide. With millions of years of accumulated silt lining its banks, the Mississippi throughout much of this length was actually higher than the surrounding countryside. Only elaborate series of high-banked earthen dikes protected many riverside towns from destruction by the river. Floods along the Mississippi were legendary, more so along the Lower Mississippi than through the stretch at Dubuque. During low water, the Lower Mississippi discharged about 70,000 cubic feet of water into the Gulf of Mexico. During flood stage this increased more than thirty times to about 2.3 million cubic feet. In especially heavy flood years, the flow increased far more, as the water-gorged river inundated its entire flood plain and overran the dikes, causing extensive property damage. William J. Peterson, *Steamboating on the Upper Mississippi* (1937; Reprint edition, Iowa City: State Historical Society of Iowa, 1968), 22-27; Henry Lewis, *The Valley of the Mississippi* (St. Paul: Minnesota Historical Society, 1967), 59-63; George S. Morison, *The Memphis Bridge* (New York: John Wiley and Sons, 1894), 7; George Conclin, *New River Guide, or a Gazeteer of All the Towns on the Western Waters* (Cincinnati: by the author, 1852), 67-71.

United States Department of the Interior
National Park Service

National Register of Historic Places
Continuation Sheet

section number 8 page 6

DUNLEITH AND DUBUQUE BRIDGE Dubuque County, Iowa

Dubuque citizens began efforts to secure a railroad from Chicago as early as 1847, when a group of city officials and businessmen formed a committee to lobby the Chicago & Galena Union Railroad for construction of a rail line. Failing that, they approached the Illinois Central Railroad, which prepared a plan to enter the city in 1850. The first railroad to enter Dubuque was the Dubuque and Pacific in 1856, the same year that Dubuque was designated a port of entry by the government. Other rail lines extended tracks into town, including the Burlington & Northern (a subsidiary of the Chicago, Burlington & Quincy system), the Chicago, Milwaukee & St. Paul and, most importantly, the Illinois Central. The railroads entered Dubuque from the east over the Mississippi River, using a single steam-powered ferry. It was a monopoly for which the city paid dearly. "The interests of Dubuque and Northern Iowa suffered for many years in consequence of the lack of transportation facilities between Dunleith and Dubuque," a county history stated in 1880. "The ferry which plied between these cities was in the hands of the Illinois Central Railroad Company, and it was charged that this medium of communication was not only a merciless monopoly, but inadequate to the purpose."⁶

Dubuque was one of several crossing points along the Mississippi River dependent upon ferry boats during the 1850s and 1860s. Over the first half of the 19th century, the river had been the exclusive province of the steamboats that hauled freight, livestock and passengers over its length. Predictably, when the railroads approached the Mississippi at mid-century with the intention of bridging the river, steamboat operators sought to protect their monopoly by mounting opposition in Congress, in the courts, even at the bridge sites themselves to prevent the rival railroads from crossing the river. The Chicago & Rock Island [C&RI] was the first railroad line to reach the Mississippi from the east, steaming the first locomotive to the bank of the river in 1854. C&RI surveyors had chosen Rock Island as the railroad's western terminus, because they reasoned that a bridge over the Mississippi at this point would be economical to build to the existing center island and would present a minimal hazard to river navigation.

Steamboat owners in St. Louis immediately cried out that the proposed bridge was "unconstitutional, an obstruction to navigation, dangerous," and complained that it was "the duty of every western state, river city, and town to take immediate action to prevent the erection of such a structure."⁷ As soon as the Railroad Bridge Company began laying foundations for the piers in 1854, Southern sectionalists led by Jefferson Davis protested its construction in favor of a transcontinental road across the southern states. The opposition proved formidable, for as Secretary of War, Davis stood in a position to block the bridge, and he ordered the railroad company to halt construction.⁸ This represented the first concerted effort to stop the bridge by the steamboat

⁶*History of Dubuque County, Iowa* (Chicago: Western Historical Company, 1880), 637.

⁷Carl Sandburg, *Abraham Lincoln: The Prairie Years* (New York: Harcourt, Brace, 1926), 37.

⁸Dee Brown, *Hear That Lonesome Whistle Blow* (New York: Holt, Rinehart and Winston, 1977), 6-8.

United States Department of the Interior
National Park Service

National Register of Historic Places
Continuation Sheet

section number 8 page 7

DUNLEITH AND DUBUQUE BRIDGE Dubuque County, Iowa

interests. Construction of the Rock Island Bridge—and the ensuing battle between the railroad and steamboats—would set the stage for bridge regulation and litigation for decades to follow.⁹

The next railroad to reach the Mississippi River from the east was the Galena & Chicago Union, which in 1855 extended tracks to Fulton, Illinois, across the river from Clinton, Iowa. This was followed by the railroad to Dunleith the following year. By 1857 no fewer than seven Chicago-based railroads had extended tracks to the eastern bank of the Mississippi, intending to bridge the river. All had obtained charters from the states on both sides of the river, but none had secured federal authorization to build bridges, blocked as they were by the Southern contingent in Congress. The Civil War effectively halted bridge construction over the Mississippi. After war's end in 1865, though, Congress quickly authorized several Mississippi River bridge projects. On July 25, 1866, President Andrew Johnson signed the enabling legislation for spans at Winona, Minnesota; Prairie du Chien, Wisconsin; Burlington, Iowa; Quincy, Illinois; Keokuk, Iowa; Hannibal, Missouri; and St. Louis. The bridge between Dunleith and Dubuque was included in this act as well.

⁹The first court challenge occurred soon after construction began in 1854, when a St. Louis merchant secured a federal injunction against the bridge, charging the C&RI with trespassing, destruction of government property and obstruction of navigation along the river. But in court the following year the bridge company prevailed. In his ruling, the judge stated that railroads had become highways in the same sense as rivers. "Neither could be suffered to become a permanent obstruction to the other, but each must yield something to the other according to the demands of the public convenience and necessities of commerce." Thus freed from legal entanglements, the railroad continued with its construction, completing the 1,535-foot wooden structure in April 1856.

Vindication in the courts and completion of construction did not assure the bridge's continued existence, however, as the steamboat companies took it upon themselves to eliminate their obstacle. Only two weeks after the first train passed over the Rock Island Bridge, the structure was struck by a riverboat. The 431-ton *Effie Afton*, caught in the swirling waters around the base of the bridge, smashed against the central pier. The impact overturned a galley stove and the boat's smokestacks, which ignited the wooden vessel. While the *Effie Afton* floundered in flames, it in turn ignited the wooden bridge. The fire destroyed the boat and one span of the bridge. Railroad officials began to suspect a plot when steamboats up and down the river that day blew their horns triumphantly, and the skipper of the *Hamburg* unfurled a large banner that read: "MISSISSIPPI BRIDGE DESTROYED. LET ALL REJOICE."

In the ensuing lawsuit, Illinois attorney Abraham Lincoln successfully represented the bridge company. Lincoln argued convincingly that travel between East and West over the railroads was as important as travel between North and South over the river. He stated that "rivers were to be crossed and that it was the manifest destiny of people to move westward and surround themselves with everything connected with modern civilization" (*Rock Island Magazine*, February 1926, 6). Despite this defeat, the river interests continued their struggle against encroachment by the railroads. In 1858 they lobbied Congress unsuccessfully for a law forbidding bridges over navigable rivers. Later that year the steamboatmen won a rare victory as an Iowa judge declared the Rock Island Bridge "a common and public nuisance" and ordered its Iowa portion demolished. The Supreme Court later overturned this decision, finally settling the issue of the railroads' right to bridge the Mississippi. Nevertheless, the steamboat interests still would use a variety of legal and illegal means to harass the railroads on subsequent bridges. Benedict K. Zobrist, "Steamboat Men Versus Railroad Men," *Missouri Historical Review*, 1965, 159-172; Dee Brown, 8-9; Walter Havighurst, *Voices on the River: The Story of the Mississippi Waterways* (New York: The Macmillan Company, 1964), 121.

United States Department of the Interior
National Park Service

National Register of Historic Places
Continuation Sheet

section number 8 page 8

DUNLEITH AND DUBUQUE BRIDGE Dubuque County, Iowa

The legislation re-ignited the fervor in Dubuque for construction of a bridge over the Mississippi. "Let Dubuque put a bridge over the Mississippi at that point and it will be a great advantage to them and the west," the editor of the *Hamilton Freeman* stated. "If Dubuque looks to her interests she will have a bridge across the Mississippi, and the D. & S. C. Road pushed west far enough to control the trade of the Boone and Des Moines valleys. The natural outlet of this section is by that road, and not the Northwestern [railroad]. Let the road now at Des Moines, and soon to be at Aimes [sic], be completed this far north, and it will require all the efforts of Dubuque to turn the tide of business."¹⁰ In June 1867 Dubuque attorney Platt Smith, businessman H.L. Stout and others incorporated the Dunleith and Dubuque Bridge Company for purposes of financing and erecting the Mississippi River bridge.¹¹ The city council fixed its location between 6th and 7th Streets, the bridge company and the Illinois Central Railroad executed a contract stipulating the terms of the structure's construction and use, and Smith and Stout traveled to Chicago to confer with capitalists about the sale of company stock to raise funds for the bridge construction.

In December 1867 the bridge company published plans and specifications for the projected structure, soliciting proposals from bridge erectors nationally. The specs were framed in general terms—stating overall dimensions and configuration and outlining performance standards—to give the contractors leeway in formulating their bids:

The superstructure will consist of two spans, 250 feet each, four spans of 225 feet each, and one draw span with equal openings of about 160 feet each, and a total length of 360 feet. The top chords of the fixed spans may be of cast iron, all other parts of the fixed spans and or the draw span being of wrought iron. Both the fixed and the draw spans must have the material so proportioned in them that the weight of the structure, estimated at 280 pounds per lineal foot, together with a moving load of 2,500 pounds per lineal foot, will in no part cause a tensile strain of over 10,000 pounds per square inch of sectional area nor a shearing strain of over 7,500 pounds to the square inch on the wrought iron. The cast iron must be so constructed as to sustain six times these weights. The wrought iron floor beams are to be of the best quality of Phoenix beams.¹²

¹⁰Quoted in "A Bridge at Dubuque." *Dubuque Daily Times*, 30 October 1866.

¹¹"The Bridge Company: Articles of Incorporation." *Dubuque Herald*, 6 June 1867:

We understand from reliable authority that pecuniary aid has been promised this enterprise provided favorable legislation shall be given it by our city government, if the council will provide for right of way for railroads through the city, and do such other work as properly comes within the line of their duty. The board of management of the Illinois Central railroad has given assurance of disposition to make a fair contract in advance for the use of the bridge when completed, which would result in the transfer of the offices of the Illinois Central to this city. This means "business," and we hope to see our citizens take hold in earnest.

¹²"Dunleith and Dubuque Bridge: Plans and Specifications." *Dubuque Herald*, 17 December 1867.

United States Department of the Interior
National Park Service

National Register of Historic Places
Continuation Sheet

section number 8 page 9

DUNLEITH AND DUBUQUE BRIDGE Dubuque County, Iowa

The substructural specifications for the bridge called for timber piles driven into the riverbed and sawed off within two or three feet of the bed's grade. The piers were to be built of stone ashlar masonry with grouted joints and course facing. "The piers, except the draw pier, shall be made round on the upper end below low water," the specs stated, "and from low to high water shall be made round or elliptical and have a batter of six inches per foot. At high water the pier will be eight feet wide on top, and the straight part of it 24 to 26 feet long. The draw pier will be octagonal shape, and about 33 or 34 feet in diameter at the top. The outer side of the pier shall be a wall about four feet wide on top with a batter of one-half inch per foot on the outer face."¹³ The specifications called for a timber trestle to be built over the slough between the bridge's western end and the railroad grade at 6th Street, a distance of some 2,400 feet. "The spans will be about 25 feet each, except in the slough, where there will be one or two spans of 55 or 50 feet in the clear, made with a braced bridge."¹⁴

In January 1868 the bridge company received bids from eight contractors. The company's directors were poised to award the contract to a Chicago-based firm (probably the Boomer Bridge Works), but industrialist Andrew Carnegie, vice president and partner of the Keystone Bridge Company of Pittsburgh, met with them in Dubuque to make his proposal directly. "He felt that his personal attention was crucial to the success of Keystone's efforts to win the contract," stated historian Robert Jackson. "This was a contract which Carnegie desperately wanted, because it played a crucial role in his plans to control certain aspects of the growing railroad business in Iowa."¹⁵ Carnegie and Keystone engineer Walter Katte extolled the structural virtues of wrought iron, finding the directors "delightfully ignorant of the merits of cast- and wrought-iron," according to Carnegie. "We had always made the upper chord of the bridge of the latter, while our rivals' was made of cast-iron. This furnished my text."¹⁶ Carnegie convinced the bridge company to award the contract for the iron superstructure to Keystone for \$275,900—suspiciously the exact amount as Boomer's proposal for a cast iron structure.

¹³"Dunleith and Dubuque Bridge."

¹⁴"Dunleith and Dubuque Bridge."

¹⁵Robert W. Jackson, "White Water Creek Bridge," *Historic American Engineering Record*: HAER No. IA-51, August 1995. Jackson continued: "Building the structure would establish Keystone as a major builder of bridges across the Mississippi. The company would therefore be in an excellent position to build other bridges which Carnegie knew must eventually span both that river and the Missouri River." The story of Carnegie's meeting with the directors of the Dunleith and Dubuque Bridge Company has become lore in local history and has been described in detail by Jackson and others, including Carnegie himself. Andrew Carnegie, *Autobiography of Andrew Carnegie* (Cambridge, Massachusetts: Riverside Press, 1920), 123-125; Robert W. Jackson, "Extant Approach Spans of the Dunleith and Dubuque Bridge," *IA: The Journal of the Society for Industrial Archeology*, Vol. 31, No. 1 (2005); Arthur Q. Larson, "Platt Smith of Dubuque: His Early Career," *The Palimpsest*, Vol. 58, No. 3 (May/June 1977); Jim Miller, "Carnegie Talked His Way into Bridge Contract," *Dubuque Telegraph-Herald*, 2 February 1973.

¹⁶Carnegie, *Autobiography*, 124.

United States Department of the Interior
National Park Service

National Register of Historic Places
Continuation Sheet

section number 8 page 10

DUNLEITH AND DUBUQUE BRIDGE Dubuque County, Iowa

Some Dubuquers objected almost immediately to the proposed bridge. Spurred by George Jones, who had operated the city's first wagon ferry before selling it to the Illinois Central, a group of citizens demanded that the bridge be configured to accommodate wagon and pedestrian traffic in addition to trains. In response, Platt Smith explained that the directors of the bridge company had contemplated the idea. They had even studied widening the steel spans from fourteen to eighteen feet, with the attendant increases in iron and masonry involved. But the directors had ultimately rejected the idea because it would be too expensive and, further, it exceeded Congressional and state charters. Such a move, Smith maintained, would make the bridge prey to the legal challenges by steamboat interests in what he characterized as their "war of extermination" against Mississippi River bridges. "No lawyer will pretend that a legislative authority to build a specified kind of bridge would authorize the construction and use of an entirely different bridge," he explained. "A railroad franchise authorizes the carrying of freight and passengers in the ordinary way of transportation by a railroad, but a toll bridge for the passage of footmen, wagons, live stock, &c., is entirely a different franchise."¹⁷ As a palliative gesture, bridge company officials offered to extend the structure to wagon use at some future date after its completion.¹⁸

While Smith was meeting with citizens' groups in the winter of 1868, construction began on the immense structure. Contractors Reynolds, Saulpaugh & Company of Rock Island had secured the contract for the substructure and piers of the bridge, having bid \$242,000. They in turn sub-contracted the pile driving to C.C. and E.G. Smith. On the morning of January 27, 1868, a force of some twenty men began excavating for the west abutment on the Dubuque end. A month later another crew maneuvered a steam engine onto some timbers resting on the river ice on the Dunleith end to begin driving piles for the easternmost pier. When the ice began weakening in early March, the men moved this and other drivers onto barges floated on the river and resumed the substructural work. Pile driving for the piers was as slow and tedious as it was loud and violent. Twelve-inch-diameter oak piles were rammed forcibly into the riverbed mud by two-thousand-pound iron hammers, which were lifted by steam engines and dropped from a distance of between ten and twenty feet onto the top of the posts. Working around the clock, each engine could drive only about seven piles per day. When the piles were forced to within two feet of riverbed's surface, they were cut off using a steam-driven

¹⁷"Dunleith and Dubuque Bridge: Why It Is Not a Wagon Bridge." *Dubuque Herald*, 3 February 1868.

¹⁸They never did. Citizens' groups continued to petition to city, county and bridge company officials for pedestrian and wagon access to the railroad bridge throughout the construction process and after. In 1873, with the structure completed and operational, the bridge company offered to lay planks down on the bridge deck and open it to wagon, stock and pedestrian use, if the county would agree to relieve the bridge company of its property tax obligation. The agreement was never struck, however, and it was not until construction of the Dubuque High Bridge in 1887 that wagons could finally cross the Mississippi River over a bridge at this point. Located only 75 feet downriver of the railroad bridge with its piers aligned with those of the earlier structure, it was configured so that the swing span of the railroad bridge rotated partially beneath the main channel span of the roadway bridge.

United States Department of the Interior
National Park Service

National Register of Historic Places
Continuation Sheet

section number 8 page 11

DUNLEITH AND DUBUQUE BRIDGE Dubuque County, Iowa

saw and capped with two layers of heavy timbers, on top of which the stone masonry was laid. Moving systematically from east to west, the men drove between 250 and 375 oak piles per pier and filled the interstitial spaces between the timbers with crushed rock. "This part of the building was done with the greatest care," according to the *Dubuque Times*, "that the spaces might be evenly filled and the piles free from obstructions." The *Times* continued:

To the end that these prerequisites might be fully complied with, men in submarine armor attended to the adjustment of the water-tight caissons, in which the stonework was done by men thereby protected from interruption by water. So skillfully was every stone in the piers prepared for its place, and each course rose above the other with such precision under the watchful eyes of the engineers and overseers, that, when an altitude of forty feet above the water had been reached, the center of the narrow top was found to be at that point of relative space required for the support of the iron superstructure, without alteration or reconstruction.¹⁹

By the end of June, stonemasons had completed the masonry on the first pier, the piles for the draw pier were in place ready for stonework, and the other piers were as yet under the pile driver. Meanwhile, another Saulpaugh crew built the timber approach structure over the west-side slough. The contractors quarried and dressed the massive stones in the East, shipped them to Dunleith by train and staged them on a levee east of the bridge. Additionally, Keystone, which had been fabricating the truss components in its Pennsylvania shops, used the levee as a staging yard for iron truss parts—"columns, pillars, braces &c., corded up like wood, in ranks and piles of mammoth proportion"—hailed in by the carload aboard the Illinois Central.²⁰

That summer the ironworkers began erection of the truss spans over timber falsework driven into the river, starting with the draw span, which, by contract, was to be completed by August 1. In mid-August, the *Times* provided a layman's view of the bridge's superstructure:

The valuable improvements in iron-bridge building perfected within the last twenty-five years were incorporated in the structure, and, unlike most of the massive railroad iron bridges of England and Continental Europe, seems like a skeleton, so light and airy that nothing but the fact of experience and the warrant of engineers induce a belief that it can sustain a train of freight-cars weighing 200 tons. To the eye, seen from a short distance, the ironwork appears to be a few large, heavy bars of iron bolted together at intervals of a few feet, perpendicular iron posts kept in place by horizontal cross rods at the top and bottom. The strength of the iron, its resisting power under tension, its weight in proportion to length, and the weight it is known to be capable of sustaining, are adjusted by mathematical formulas, based on the most rigid experiments which science can devise, and combined in a structure of the least weight with the greatest strength possible in view of the purpose intended. Tempests may sweep the river, but will produce no

¹⁹"Bridges Across the Mississippi: The Dubuque and Dunleith Bridge." *Dubuque Daily Times*, 16 August 1868.

²⁰"The Railroad Bridge: Progress of the Construction." *Dubuque Herald*, 30 June 1868.

United States Department of the Interior
National Park Service

National Register of Historic Places
Continuation Sheet

section number 8 page 12

DUNLEITH AND DUBUQUE BRIDGE Dubuque County, Iowa

effect on such a triumph of mechanical skill. Here is open ironwork, graceful in structure, beautiful in design, and representing \$750,000 worth of the use of American brains and labor to promote commercial interests with facility and profit.²¹

Work on the bridge's superstructure continued through the fall of 1868. In November the steelworkers finished erection of the trusses and were working on the deck and tracks. On December 15, two weeks before the bridge was scheduled to be complete, the engineers performed its first load-testing by steaming a locomotive and a passenger car over it. A week later, the test was repeated with seven locomotives parked on the draw span in sub-zero temperature; on January 1, 1869, the structure was turned over by the contractors to the bridge company and opened to rail traffic. Total cost: about \$800,000.

s one of the few functioning spans then over the Mississippi River, the Dunleith and Dubuque Bridge immediately began carrying trains of the Illinois Central and other railroads. Its importance to interstate commerce and to the economy of Dubuque could hardly be overstated. The structure ensured Dubuque's role as a regional trade nexus and, on a broader scope, helped facilitate the western movement after the Civil War. The bridge carried freight and passenger trains—but not foot and wagon traffic. A wooden sign bolted to the Dubuque endpost exhorting people to "Keep off the Bridge" prevented some, but not all, pedestrians from crossing.

The bridge's weak link was the extensive trestle over the slough on its western end. Built with timber stringers over timber piles, it could hardly be considered a permanent structure and was regarded by the bridge company as a stopgap measure. In January 1870, only a year after spending over \$50,000 building the slough approach structure, company officials resolved to replace a portion of the trestle with two iron trusses. This construction was never undertaken, however, and a year later the board of directors instead moved to replace the trestle entirely with eight iron trusses, each spanning 93 feet. They contracted with the Keystone Bridge Company to fabricate and erect the trusses for \$45,000 and with Saulpaugh, Reynolds & Company to drain the sloughs and build the substructure and masonry piers for \$55,000.

The spans would be Pratt through trusses, configured identically to the fixed spans on the original bridge. By reconfiguring the direction of the approach and angling the installation of the trusses over the piers to accom-

²¹"Bridges Across the Mississippi." The newspaper wrote enthusiastically about the structure then underway:

We cannot help anticipating the pleasure which thousands, yes hundreds of thousands, will receive in comprehending the view they will have from this bridge. When the bridge is finished and all the temporary structures incident to its building removed, it will stand as the best embellishment of our city, and many of our short sighted citizens who only a year ago opposed the building of the bridge will then be happy to say to their friends, "Why see here, the advantages of Dubuque and the whole country west of it!"

United States Department of the Interior
National Park Service

National Register of Historic Places
Continuation Sheet

section number 8 page 13

DUNLEITH AND DUBUQUE BRIDGE Dubuque County, Iowa

moderate a curved track alignment, the engineers were able to eliminate the need for one of the spans, although the company had already contracted—and eventually paid—for all eight.²² Built in 1871-1872 for \$131,000, the bridge was completed and tested early in 1872. Testing was carried out using standard practice, with two locomotives and tenders fully loaded with coal and water driven over each of the spans while engineers measured the spans' deflection under load. The trusses passed inspection, and the new approach structure was accepted by the bridge company.²³



With a permanent structure forming its western approach, the Dunleith and Dubuque Bridge could finally be considered complete, and little changed about it over the next few years. In October 1877 a fire destroyed the engine house on the swing span, and nine years later a locomotive plunged into the river through the open draw span, but neither incident caused appreciable damage to the structure.²⁴ In 1880 the bridge company engaged notable bridge engineer George S. Morison to inspect the bridge. Acting as Assistant Engineer to Octave Chanute in 1868-1869, Morison had overseen the construction of the swing-span Kansas City Bridge, the first permanent structure over the Missouri River. He had then engineered the Erie Railroad's Portage Viaduct in New York, as well as other structures in the East, before undertaking a series of large-scale railroad bridges over the major Midwestern rivers. Morison was supervising erection of the first of these, the Plattsmouth Bridge over the Missouri River in Nebraska, when he was called to consult at Dubuque.²⁵

²²The unassembled components of the eighth span were stored until the company was able to sell them in November 1874 to the Chicago, Burlington & Quincy Railroad for \$2,686.00. The truss was erected over the Volga River in Clayton County for a CB&Q subsidiary, the Chicago, Dubuque & Minnesota Railroad. Robert Jackson, "Extant Approach Spans," 10.

²³"The New Iron R.R. Bridges." *Dubuque Daily Times*, 17 January 1872.

²⁴"Damaged by Fire." *Dubuque Daily Times*, 30 October 1877; "Into the River." *Dubuque Daily Times*, 17 Sept 1886.

²⁵As one of the most highly regarded bridge engineers in America, Morison would later engineer other Missouri River railroad bridges at Blair Crossing, Omaha, Rulo, Nebraska City, Bismarck and Sioux City—all fixed-span high bridges that employed Whipple through trusses for their superstructures. Morison also designed the Cairo Bridge over the Ohio River, the longest steel structure in the world at the time of its completion, as well as major bridges over the Mississippi River at Winona, St. Louis, Leavenworth, Burlington and Alton. His most noteworthy achievement was the design and erection of the high bridge over the Mississippi at Memphis in 1891-1893, a cantilevered through truss that was the first such structure built over the Lower Mississippi and the longest-span bridge in the world at the time of its completion. Clayton B. Fraser, *Behemoths: The Great River Bridges of George S. Morison*, Historic American Engineering Record (HAER No. NE-2), October 1986.

United States Department of the Interior
National Park Service

National Register of Historic Places
Continuation Sheet

section number 8 page 14

DUNLEITH AND DUBUQUE BRIDGE Dubuque County, Iowa

In his final report to bridge company president William Allison, made in June 1880, Morison was nothing if not thorough. The Dubuque Bridge, he stated, was generally well engineered and well maintained, comparing favorably with other, similarly scaled structures of its time. Its fixed spans were superior to those on the Quincy and Burlington bridges, though the draw span was not their equal. Taking into account the improvements in design, fabrication and erection that had been made over the intervening twelve years, the Dunleith and Dubuque Bridge was not as advanced as his own structure at Plattsmouth and other bridges currently being built over the Missouri and Mississippi Rivers. The principal defect in the structure, Morison noted, was that the cross ties had been laid too far apart for the newer, heavier locomotives and had been inadequately secured to the bridge's floor beams to prevent a derailed train from breaking through.

Morison's analysis of the Dubuque approach bridge trusses was exhaustive. He commented on its truss spans, stating that their design was somewhat more advanced than that of the fixed spans of the original structure. The posts and laterals of the approach spans, he observed, were pin-connected to the upper chords, where the connections on the original bridge were made with gusset plates and screws. And the floor beam hangers for the approach spans, though considerably smaller than those on the original bridge, were adequate. Morison's main concern involved the fabrication of the tension members. The eyebars had all been forged, with the ends formed by bending the square iron bars back onto themselves and welding them into a teardrop-shaped hole for the pins. The hand-forging, while sufficiently strong, produced bars of slightly unequal lengths, which placed significantly different strains on parallel members. Boring the pin holes would have been more satisfactory, he concluded.²⁶

In subsequent years, the marshy bottomland on the structure's west end was filled, and the 1872 approach spans were replaced with earth and stone fill. To help defray the cost of marsh reclamation, the bridge company offered the iron trusses for sale. The westernmost two spans were the first to go, dismantled and sold to E.A. Spaulding in November 1887 for \$750 each. Spaulding had been responsible for much

²⁶The original bridge was reconstructed incrementally during the following years, beginning with the draw span, which was rebuilt in 1893 by the Keystone Bridge Company. The easternmost fixed span was replaced with fill in 1899, and the next three fixed spans to the west were replaced with newer trusses at that time. In 1903 truss replacements for the last two fixed spans were reported under construction. According to F.B. Maltby:

The new spans are being built by the American Bridge & Iron Works of Chicago, and have sloping top chords, the center panel only being horizontal. Panels are about 25 feet long. The trusses are built for a single track and are designed for a loading of two 160-ton engines followed by a train load of 4,600 lbs. Per foot. It will be noticed that the old spans were in use somewhat over thirty years.

F.B. Maltby, "The Mississippi River Bridges: Historical and Descriptive Sketch of the Bridges over the Mississippi River," *Journal of the Western Society of Engineers*, 8 (August 1903), 457; George S. Morison, Plattsmouth, Nebraska, to W.B. Allison, President, Dunleith and Dubuque Bridge Company, 18 June 1880; George S. Morison, Index to Engineering Drawings, hand-written note cards, located in George Morison Collection, Peterborough, New Hampshire.

United States Department of the Interior
National Park Service

National Register of Historic Places
Continuation Sheet

section number 8 page 15

DUNLEITH AND DUBUQUE BRIDGE Dubuque County, Iowa

of the slough work, and he paid for the spans, not in cash, but with labor performed for the bridge company. The easternmost two spans were sold in October 1889 to contractor E.E. Firth, also for \$750 each, also in exchange for work done for the bridge company. The company sold two of the remaining three trusses for \$600 each to the Illinois Central Railroad in December 1892 for use elsewhere. The final span was dismantled and stored for another two years, before the bridge company sold it also to the Illinois Central Railroad. It was erected in 1895 by the Yazoo & Mississippi Valley Railroad (an IC subsidiary) at the Fairground Street overpass in Vicksburg, Mississippi.²⁷

Iowa Department of Transportation records indicate that two of the seven trusses from the Dubuque approach bridge were acquired by Dubuque County around 1890 for use as county road crossings. The date given suggests that these might have been the two easternmost spans, purchased by the county from Firth. The spans were erected on county roads at two different locations—one over the Cloie Branch of the Maquoketa River near Sageville, about six miles north of Dubuque, the other over White Water Creek, about five miles east of Cascade in the county's south-central quadrant. The Cloie Branch and the White Water Creek structures were hauled in pieces and erected over stone abutments, with original railroad deck replaced by timber stringers and deck to carry wagon traffic. Steel lattice guardrails, unnecessary on the railroad bridge, were installed to the inside of the webs on both trusses.

The two structures carried vehicular traffic at their respective crossings for about 100 years. Both were functioning in place with iron superstructures, steel guardrails and timber deck structures unaltered when they were documented as part of the statewide Historic Bridge Inventory in 1989. Flooding in July 1993 damaged the approaches to the White Water Creek Bridge, necessitating its temporary closure, but it was repaired and re-opened. At about the same time the county replaced the Cloie Branch structure and moved the 1872 truss to one side of the Dubuque County Heritage Trail nearby.²⁸ In 1995 the White Water Creek Bridge was documented in place by the Historic American Engineering Record as part of the Iowa Historic Bridges Recording Project [Figs. 5-9]. Three years later it was individually listed in the National Register.



At that time Dubuque County was making preparations for replacement of the White Water Creek Bridge, budgeting \$275,000 for construction of a new concrete structure here. Building the replacement bridge would necessarily entail removal of the 1872 truss and demolition of the original abutments. The county had secured a right-of-way for the new structure in December 1996 from Cyril N. and

²⁷The Dubuque truss was shortened by one panel and combined with another span fabricated by the Keystone Bridge Company to form the Fairground Street Bridge in Vicksburg, Mississippi. It continues to carry vehicular and pedestrian traffic.

²⁸The truss remains in place here, supported by concrete slabs at the corners, with a wooden partial deck recently built over the original iron floor beams.

United States Department of the Interior
National Park Service

National Register of Historic Places
Continuation Sheet

section number 8 page 16

DUNLEITH AND DUBUQUE BRIDGE Dubuque County, Iowa

Marilyn Wolfe, owners of the adjacent farm property. The following June the City of Dubuque agreed to salvage the truss if the county would move it for temporary storage on the Wolfe farm until the City could make plans and obtain funds to move it.²⁹

Work commenced in May 1999 with the removal of the 1872 truss. It was hauled by two cranes and placed on blocks in a nearby field, and the Schroeder Construction Company of Bellevue, Iowa, constructed the replacement structure that summer. In subsequent years the City of Dubuque planned the truss's relocation. As intended, the structure would be moved to the Bergfeld Recreation Area in western Dubuque, where it would be restored and erected on new concrete abutments over the Bergfeld Recreation Pond. After installation of a deck and guardrails, the truss would then carry a hard-surfaced 1.7-mile pedestrian trail over the inlet at the pond's northern tip. Funding for the project was provided in part through grants awarded by the State Historical Society of Iowa.³⁰

After resting for eleven years in place on the Wolfe farm, the truss was moved on August 3, 2010. Goodwin House Moving of Washington, Iowa, jacked the structure up onto timber cribs, inserted steel I-beams beneath its original floor beams, and hauled the immense structure away from its storage site while the Wolfe family hosted a bridge-moving party nearby. "We're so used to looking at it, it's hard to believe it's going to go," stated Janell Klostermann, one of the Wolfe children. "If they could have moved it out of here around the turn of the century, for gosh sakes, they can get it back to Dubuque," added her sister, Diane Harris.³¹ Once positioned beside the pond at Bergfeld Park, the truss was wrapped in plastic and sandblasted before being moved onto the concrete abutments. Total cost for the moving, restoration and erection of the truss was \$180,000. Sensitively rehabilitated, it again offers an opportunity for interpretation of this important aspect of Dubuque history.

²⁹Much of the information concerning the recent history of the White Water Creek span comes from newspaper clippings, documents and photographs collected in a loose-leaf binder by Ms. Diane Harris, one of the daughters of Cyril and Marilyn Wolfe. Ms. Harris has documented the move of the truss from Cascade to Dubuque, photographing the process extensively. She generously provided access to this binder to the City of Dubuque's Engineering Department, and it has provided valuable research for the preparation of this nomination. The consultant gratefully acknowledges her assistance with the truss's documentation.

³⁰The State Historical Society provided two grants: a Historic Resources Development Grant (\$30,000) to relocate the bridge to the Bergfeld Recreation Area; and a Historic Sites Preservation Grant (\$55,250) to restore and erect the bridge. The City of Dubuque matched the grants through Bridge Maintenance funds. Additionally, a private donation of \$10,000 was made to install lighting for the bridge.

³¹ Craig D. Reber, "Spanning the Years," *Dubuque Telegraph-Herald*, 7 August 2010.

United States Department of the Interior
National Park Service

National Register of Historic Places
Continuation Sheet

section number 8 page 17

DUNLEITH AND DUBUQUE BRIDGE Dubuque County, Iowa

Criteria Consideration B

This truss span from the Dunleith and Dubuque Bridge has been moved since its original construction—twice. The first relocation occurred when the bridge company replaced the structure and Dubuque County purchased it for erection on a rural county road. This action was taken as a matter of expediency by both the bridge company and the county: the company was able to sell an obsolete truss and the county acquired a heavy-duty iron span for relatively little money. Once rebuilt, the bridge carried vehicular traffic for a century in relative obscurity before it was documented by the statewide Historic Bridge Inventory and its superlative significance recognized. Despite the move and consequent loss of integrity, the bridge was listed individually in the National Register in 1998 on the basis of this significance.

Even before this listing, Dubuque County was planning the truss's replacement, and the City of Dubuque was planning its salvage. The county had no practical alternative to removing the bridge from its existing substructure in order to build the new span. And there was no question of the city's intent in acquiring the truss. The Intergovernmental Agreement between the county and the city, executed within days of its NR listing in June 1998, states that both entities were "interested in the historical significance of the bridge," and the city was "interested in salvaging the historic bridge for future use in the City's planned bicycle and pedestrian network." Preservation was the ultimate goal for both the county and the city. Before its erection in the city park, the bridge was restored in accordance with the Secretary of the Interior's Guidelines. The move and restoration were funded by preservation grants made by the State Historic Preservation Office. Preparation of this nomination was stipulated by SHPO in the grant agreements.

National Register Bulletin 15 lists properties designed to be moved among those that qualify under Criteria Consideration B, and it mentions specifically "a bridge relocated from one body of water to another". Trusses, particularly early pin-connected trusses, have historically been moved from one location to another as circumstances have warranted. Such moves may impinge on their integrity of location, setting, feeling and association, but their integrity of design, materials and workmanship often remains intact. That is certainly the case with this truss in Dubuque. Although it has lost much of its locational integrity, it is still exceedingly significant as an early technological artifact. The subsequent move does not diminish this significance appreciably. And its recent restoration and relocation to a widely visited facility enhances its interpretive value. Moved to Bergfeld Park as the best alternative to assure its preservation, the Dunleith and Dubuque Bridge thus qualifies for listing in the National Register under Criteria Qualification B. In a manner of speaking—and with tongue somewhat in cheek—it could be said that the Dunleith and Dubuque Bridge in its new emplacement actually accrues a heightened degree of significance because it is now closer to its original home.

United States Department of the Interior
National Park Service

National Register of Historic Places
Continuation Sheet

section number 9 page 18

DUNLEITH AND DUBUQUE BRIDGE Dubuque County, Iowa

Major Bibliographical References

Aldrich, Mark. "Engineering Success and Disaster: American Railroad Bridges, 1840-1900." *Railroad History* 180 (Spring 1999).

"Andrew Carnegie Got Contract for Bridge at Dubuque." *Dubuque Telegraph-Herald*, 8 May 1927.

"Another Bridge Test." *Dubuque Herald*, 23 December 1868.

"The Bridge and the Ferry: A Charge of Neglect and Extortion Made Against the Two Corporations." *Dubuque Daily Times*, 29 August 1869.

"A Bridge at Dubuque." *Dubuque Daily Times*, 30 October 1866.

"The Bridge Company: Articles of Incorporation." *Dubuque Herald*, 6 June 1867.

"The Bridge Contract Let." *Dubuque Herald*, 14 January 1868.

"Bridges Across the Mississippi: The Dubuque and Dunleith Bridge." *Dubuque Daily Times*, 16 August 1868.

Brown, Dee. *Hear That Lonesome Whistle Blow*. New York: Holt, Rinehart and Winston, 1977.

Carnegie, Andrew. *Autobiography of Andrew Carnegie*. Cambridge, Mass.: Riverside Press, 1920.

Childs, Chandler C. *Dubuque: Frontier River City*. Dubuque: Research Center for Dubuque Area History, 1984.

"City Council." *Dubuque Daily Times*, 13 December 1873.

City of Dubuque. "White Water Creek Bridge: Phase 1 – Relocation." Construction drawings for relocation and reconstruction of bridge. Located at Dubuque City Engineer's Office, 2010.

Conclin, George. *New River Guide, or a Gazeteer of All the Towns on the Western Waters*. Cincinnati: by the author, 1852.

Cooper, Theodore. "The Use of Steel for Bridges." *Transactions of the American Society of Civil Engineers* 436 (1879).

United States Department of the Interior
National Park Service

National Register of Historic Places
Continuation Sheet

section number 9 page 19

DUNLEITH AND DUBUQUE BRIDGE Dubuque County, Iowa

Costello, Mary Charlotte Aubry. *Climbing the Mississippi River Bridge by Bridge, Vol. 1*. By the author, 1995.

"Damaged by Fire." *Dubuque Daily Times*, 30 October 1877.

Dickel, Dean. "Many Bridges to Cross." *Dubuque Telegraph-Herald*, 31 July 1994.

Dubuque County. "Resolutions No. 96-356 and 97-198." 2 December 1996 and 30 June 1997.

"Dunleith and Dubuque Bridge: Plans and Specifications." *Dubuque Herald*, 17 December 1867.

"Dunleith and Dubuque Bridge: Sketch of the Bridge Enterprise." *Dubuque Herald*, 23 December 1868.

"Dunleith and Dubuque Bridge: Why It Is Not a Wagon Bridge." *Dubuque Herald*, 3 February 1868.

Everly, John. "Supervisors Approve Loan to Cascade Group." *Dubuque Telegraph-Herald*, 2 November 2004.

Everly, John, and Becky Sisco. "Railroads Made Tracks in Tri-States." *Dubuque Telegraph-Herald*, 23 September 2001.

"The First Train Crosses the Bridge." *Dubuque Daily Times*, 23 December 1868.

Fraser, Clayton B. *Behemoths: The Great River Bridges of George S. Morison*, Historic American Engineering Record: HAER No. NE-2, October 1986.

Fraser, Clayton B. "Iowa Historic Bridge Inventory." Cultural Resource Management Report for Iowa Department of Transportation, 1994.

"Great Bridge Meeting." *Dubuque Herald*, 20 February 1868.

"The Great Work." *Dubuque Daily Times*, 15 December 1867.

Greiner, J.E. "What Is the Life of an Old Iron Railroad Bridge?" *Transactions of the American Society of Civil Engineers* 764 (October 1895).

Harris, Diane. "White Water Creek Bridge." Collection of articles, reports and photographs pertaining to White Water Creek Bridge. Electronic file located at Dubuque City Engineer's Office, Dubuque, Iowa.

Havighurst, Walter. *Voices on the River: The Story of the Mississippi Waterways*. New York: The Macmillan Company, 1964.

United States Department of the Interior
National Park Service

National Register of Historic Places
Continuation Sheet

section number 9 page 20

DUNLEITH AND DUBUQUE BRIDGE Dubuque County, Iowa

History of Dubuque County, Iowa. Chicago: Western Historical Company, 1880.

"Important Arrangement: The New Railroad Outlet from Dubuque to the Markets." *Dubuque Daily Times*, 29 April 1869.

"Into the River." *Dubuque Daily Times*, 17 September 1886.

Iowa Department of Transportation, Structure Inventory and Appraisal: Structure Number 146040.

Jackson, Robert W. "Extant Approach Spans of the Dunleith and Dubuque Bridge." *IA: The Journal of the Society for Industrial Archeology*. Vol. 31, No. 1 (2005).

Jackson, Robert W. "White Water Creek Bridge." *Historic American Engineering Record*: HAER No. IA-51, August 1995.

Keystone Bridge Company. *Descriptive Catalogue of Wrought-Iron Bridges*. Philadelphia: Allen, Lance & Stout, 1875.

Klauer, John. "County to Replace Whitewater Dr. Bridge. Board Approves Rezoning East of Town." *Dubuque Telegraph-Herald*, 17 March 1999.

Kruse, Len. *My Old Dubuque: Collected Writings on Dubuque Area History*. Dubuque: Center for Dubuque History, 2000.

Larson, Arthur Q. "Platt Smith of Dubuque: His Early Career." *The Palimpsest*. Vol. 58, No. 3 (May/June 1977).

Lewis, Henry. *The Valley of the Mississippi*. St. Paul: Minnesota Historical Society, 1967.

Lyon, Randolph W. *Dubuque: The Encyclopedia*. Dubuque: First National Bank of Dubuque, 1991.

Maltby, F.B. "The Mississippi River Bridges: Historical and Descriptive Sketch of the Bridges over the Mississippi River." *Journal of the Western Society of Engineers*, 8 (August 1903).

"Men in the Tower." *Dubuque Telegraph-Herald*, 19 January 1902.

Miller, Jim. "Carnegie Talked His Way into Bridge Contract." *Dubuque Telegraph-Herald*, 2 February 1973.

Morison, George S. *The Memphis Bridge*. New York: John Wiley and Sons, 1894.

United States Department of the Interior
National Park Service

National Register of Historic Places
Continuation Sheet

section number 9 page 21

DUNLEITH AND DUBUQUE BRIDGE Dubuque County, Iowa

"The New Iron R.R. Bridges." *Dubuque Daily Times*, 17 January 1872.

Peterson, William J. *Steamboating on the Upper Mississippi*. 1937; Reprint edition, Iowa City: State Historical Society of Iowa, 1968.

"Railroad and Bridge Matters." *Dubuque Herald*, 5 February 1868.

"The Railroad Bridge." *Dubuque Herald*, 31 January 1877.

"Railroad Bridge." *Dubuque Telegraph-Herald*, 15 October 1933.

"The Railroad Bridge: Progress of the Construction." *Dubuque Herald*, 30 June 1868.

Reber, Craig D. "Spanning the Years." *Dubuque Telegraph-Herald*, 23 June 2010.

Sandburg, Carl. *Abraham Lincoln: The Prairie Years*. New York: Harcourt, Brace, 1926.

Schneider, Charles C. "The Evolution of the Practice of American Bridge Building." *Transactions of the American Society of Civil Engineers* 54 (1905).

"Senator Allison's Views on the Wagon Bridge." *Dubuque Daily Times*, 25 December 1873.

Stock, Erin. "Tri-State Historical Efforts Receive Grant Money." *Dubuque Telegraph-Herald*, 8 August 2004.

"Studies Span History of Bridges." *Dubuque Telegraph-Herald*, 12 April 1997.

Templer, John. "Dubuque's Railroad Bridge." *Dubuque Telegraph-Herald*, 22 December 1968.

Waddell, J.A.L. *Bridge Engineering*. New York: John Wiley & Sons, 1916.

Wilkie, William E. *Dubuque on the Mississippi: 1788-1988*. Dubuque: Loras College Press, 1987.

Zobrist, Benedict K. "Steamboat Men Versus Railroad Men." *Missouri Historical Review*, 1965.

United States Department of the Interior
National Park Service

National Register of Historic Places Continuation Sheet

section number 10 page 22

DUNLEITH AND DUBUQUE BRIDGE Dubuque County, Iowa

Verbal Boundary Description

The nominated boundaries enclose the structure itself—including the iron truss and its concrete abutments—and the property it occupies, without any surroundings.

Boundary Justification

The truss and its abutments, the boundaries of which form a rectangle 22 feet by 96 feet.

United States Department of the Interior
National Park Service

National Register of Historic Places Continuation Sheet

section number appendices page 23

DUNLEITH AND DUBUQUE BRIDGE Dubuque County, Iowa

Index to Photographs

Name of property: Dunleith and Dubuque Bridge
City or vicinity: Dubuque
County / state: Dubuque County, Iowa
Photographer: Clayton B. Fraser
Date of photographs: June 2012
Inkjet prints: Epson Stylus Pro 4000 Printer with Ultrachrome Ink printed on Epson
Archival Matte paper

Description of views:

- Photo number 1: General view of bridge and Bergfeld Recreation Area. View to south.
- Photo number 2: General view of bridge and Bergfeld Recreation Area. View to southeast.
- Photo number 3: North web of bridge. View to south.
- Photo number 4: West portal of bridge. View to east.
- Photo number 5: South web and west portal of bridge. View to northeast.
- Photo number 6: West abutment and northwest bearing shoe of bridge. View to south.
- Photo number 7: Typical lower chord / vertical / floor beam connection on bridge. View to south-west.
- Photo number 8: Typical upper chord / end post connection of bridge. View to east.
- Photo number 9: Typical upper chord / vertical connection of bridge. View to northeast.

United States Department of the Interior
National Park Service

National Register of Historic Places Continuation Sheet

section number appendices page 24

DUNLEITH AND DUBUQUE BRIDGE

Dubuque County, Iowa

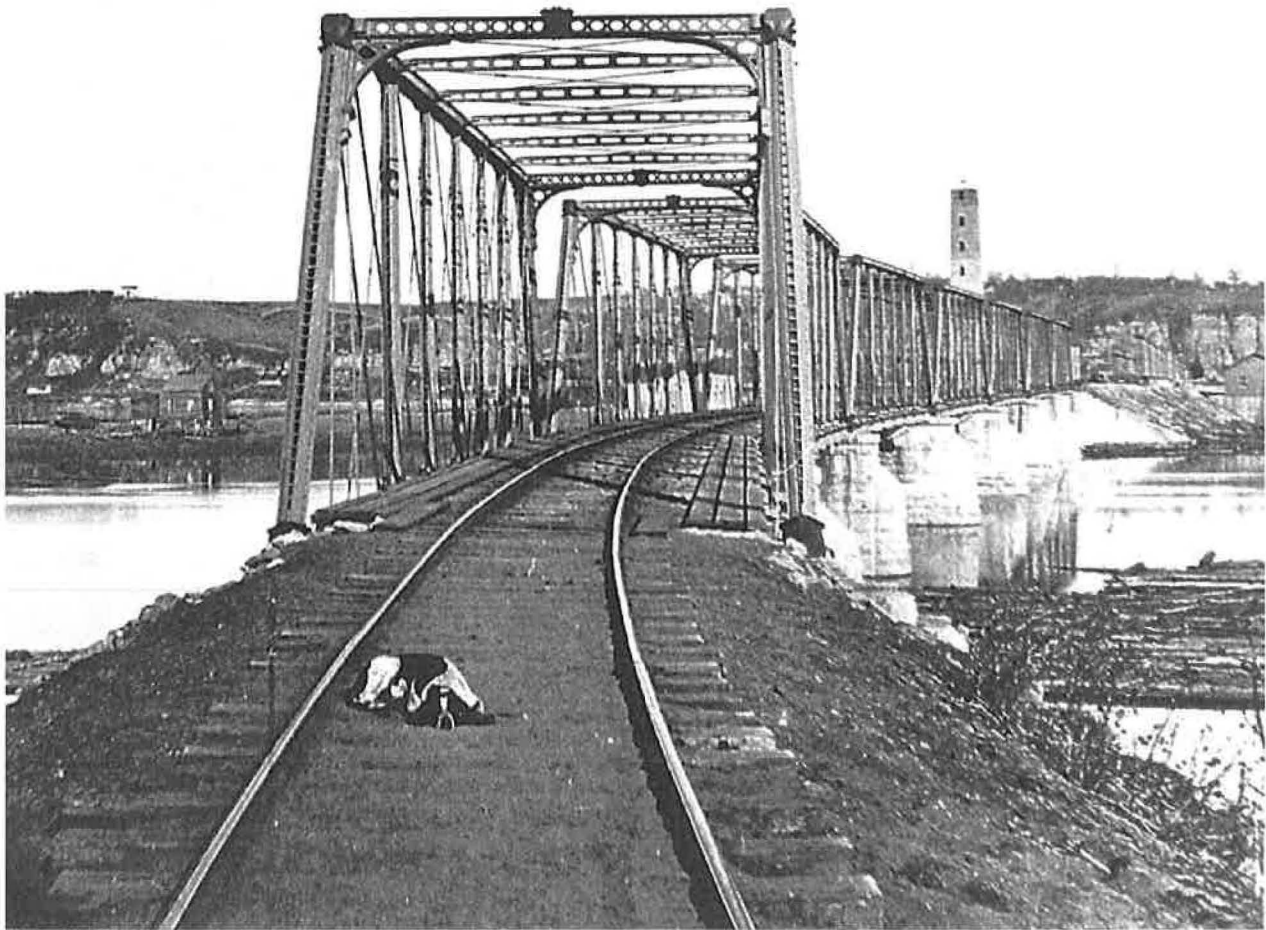

Fig. 1 Dunleith & Dubuque Bridge – Western Approach, ca. 1880 (from Robert W. Jackson, "Extant Approach Spans of the Dunleith and Dubuque Bridge," *IA, The Journal of the Society for Industrial Archeology* 31:1 (2005)).

United States Department of the Interior
National Park Service

National Register of Historic Places Continuation Sheet

section number appendices page 25

DUNLEITH AND DUBUQUE BRIDGE

Dubuque County, Iowa



Fig. 2 White Water Creek Bridge, 1989 (from collection of the author).

United States Department of the Interior
National Park Service

National Register of Historic Places
Continuation Sheet

section number appendices page 26

DUNLEITH AND DUBUQUE BRIDGE Dubuque County, Iowa

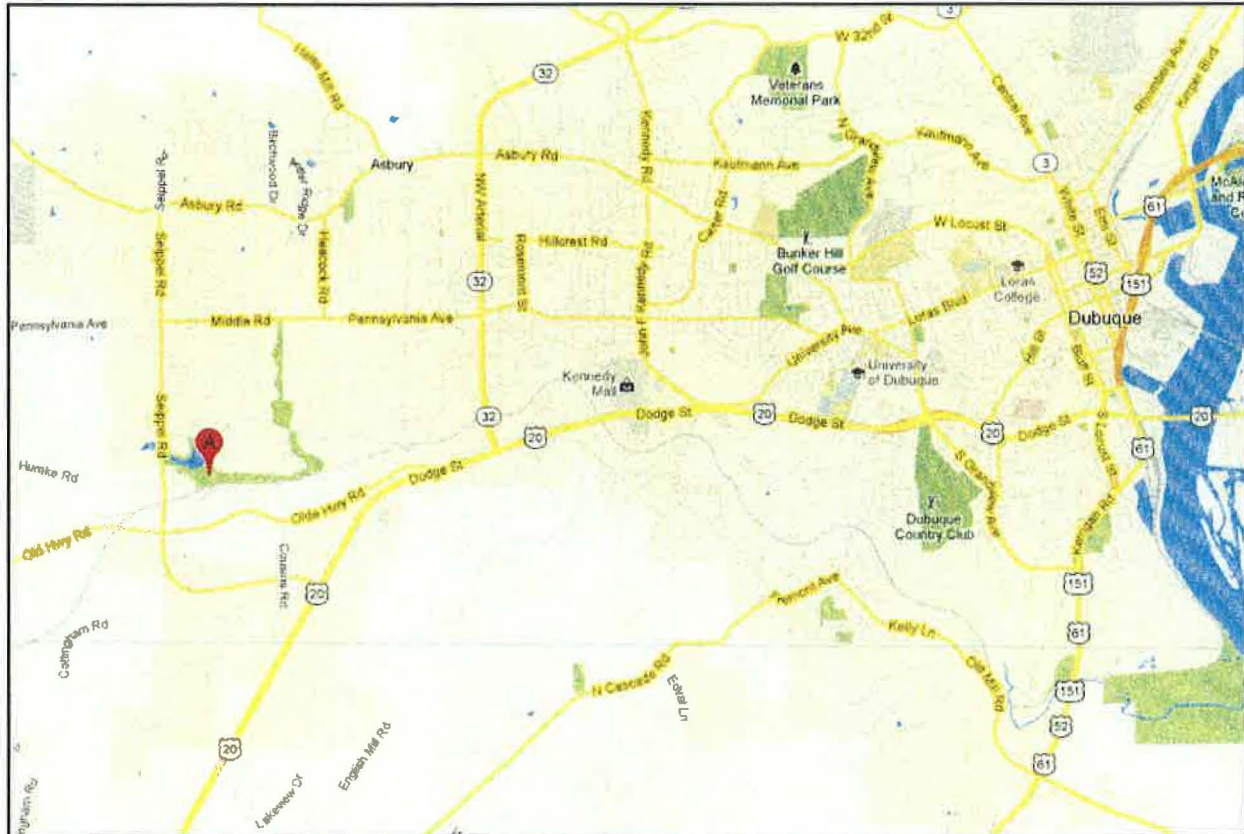

Fig. 3 Location Map, from Google Maps (Note: Bergfeld Recreation Park indicated by "A")

United States Department of the Interior
National Park Service

National Register of Historic Places
Continuation Sheet

section number appendices page 27

DUNLEITH AND DUBUQUE BRIDGE Dubuque County, Iowa

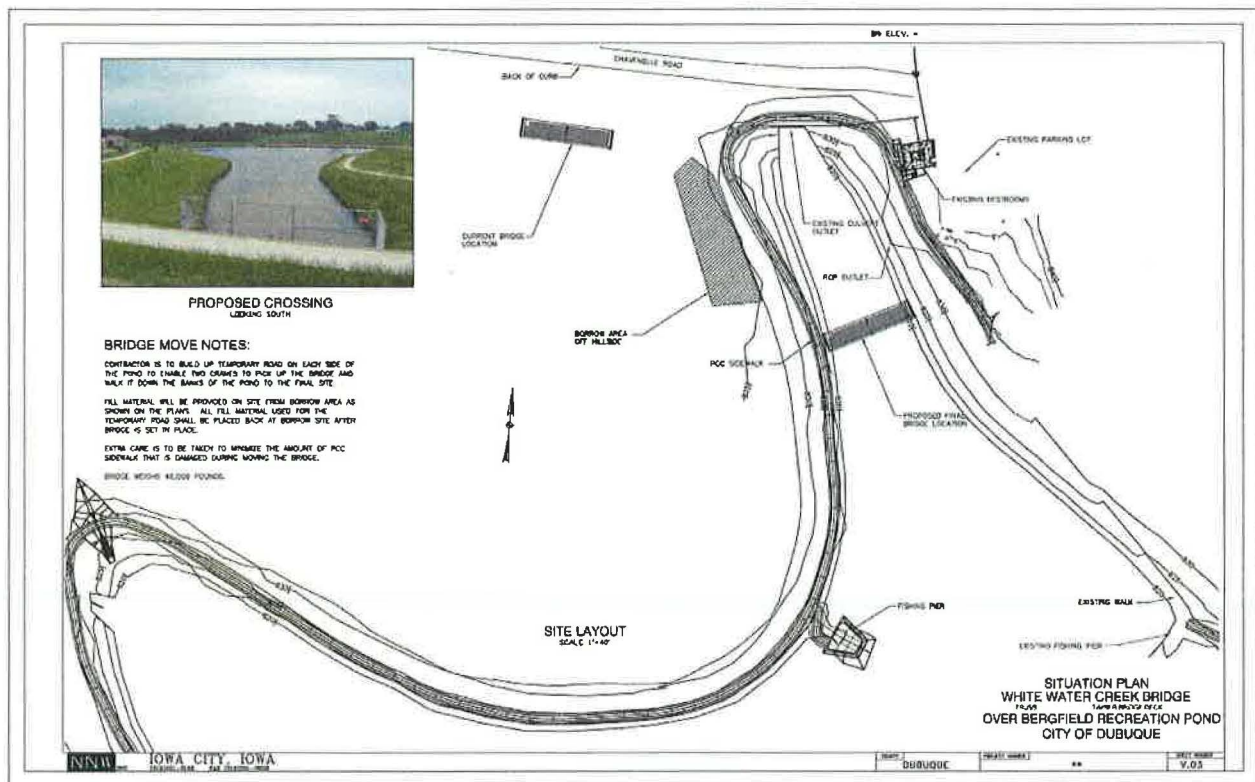

Fig. 4 Situation Plan – White Water Creek Bridge over Bergfield (sic) Recreation Pond.

United States Department of the Interior
National Park Service

National Register of Historic Places Continuation Sheet

section number appendices page 28

DUNLEITH AND DUBUQUE BRIDGE Dubuque County, Iowa

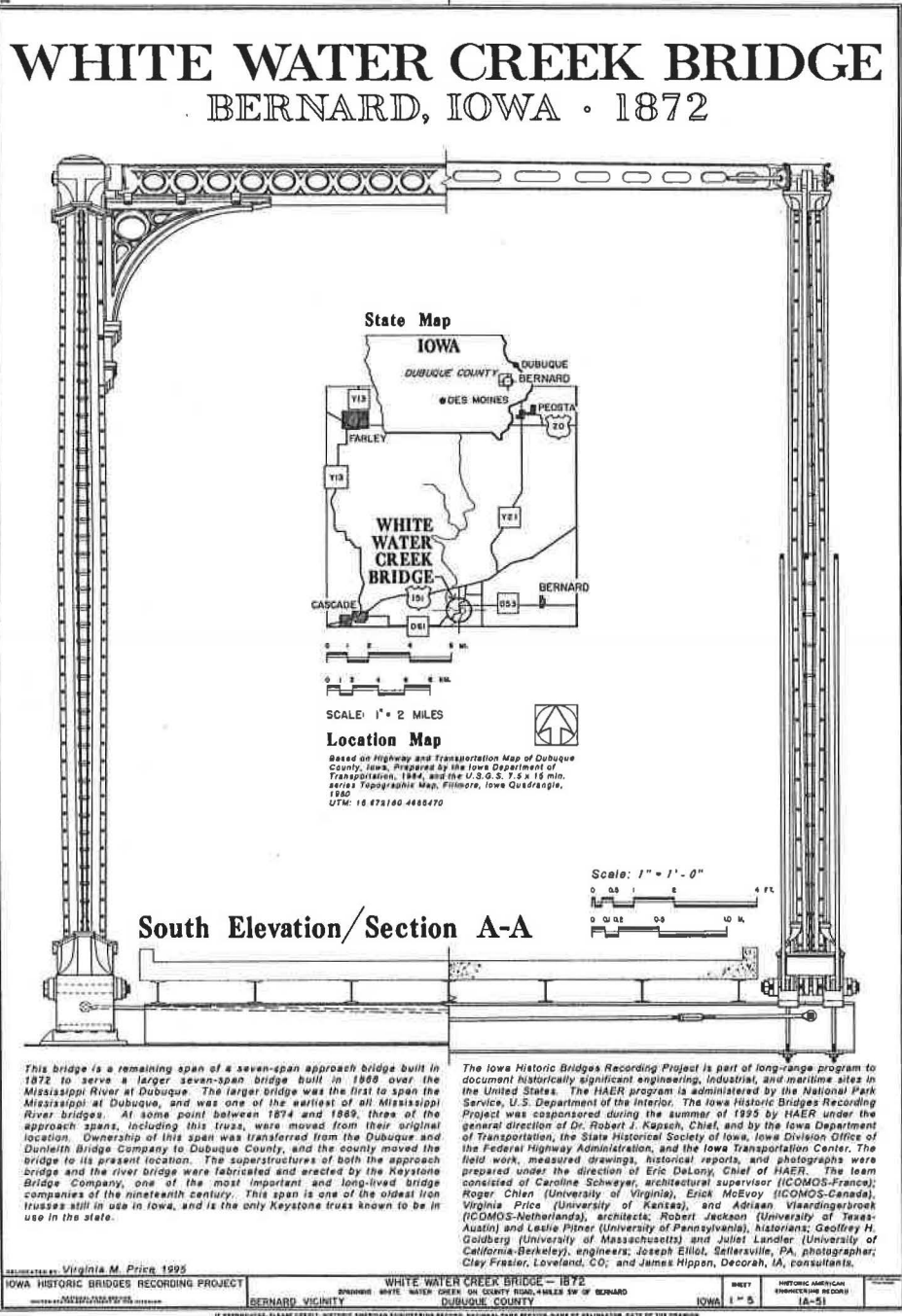

Fig. 5 Historic American Engineering Record drawing, 1995

United States Department of the Interior
National Park Service

National Register of Historic Places Continuation Sheet

section number appendices page 30

DUNLEITH AND DUBUQUE BRIDGE Dubuque County, Iowa

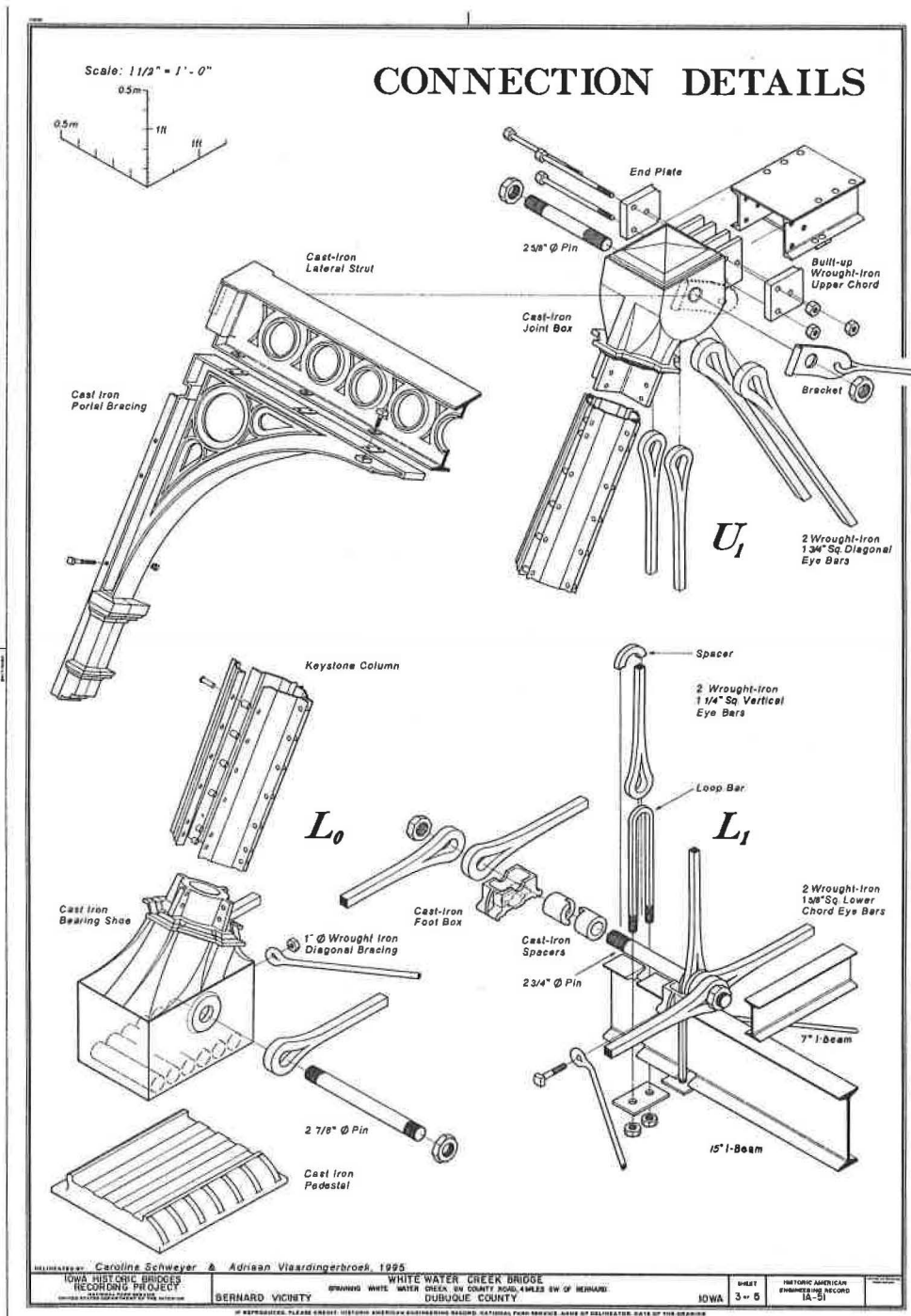

Fig. 7 Historic American Engineering Record drawing, 1995

United States Department of the Interior
National Park Service

National Register of Historic Places Continuation Sheet

section number appendices page 31

DUNLEITH AND DUBUQUE BRIDGE

Dubuque County, Iowa

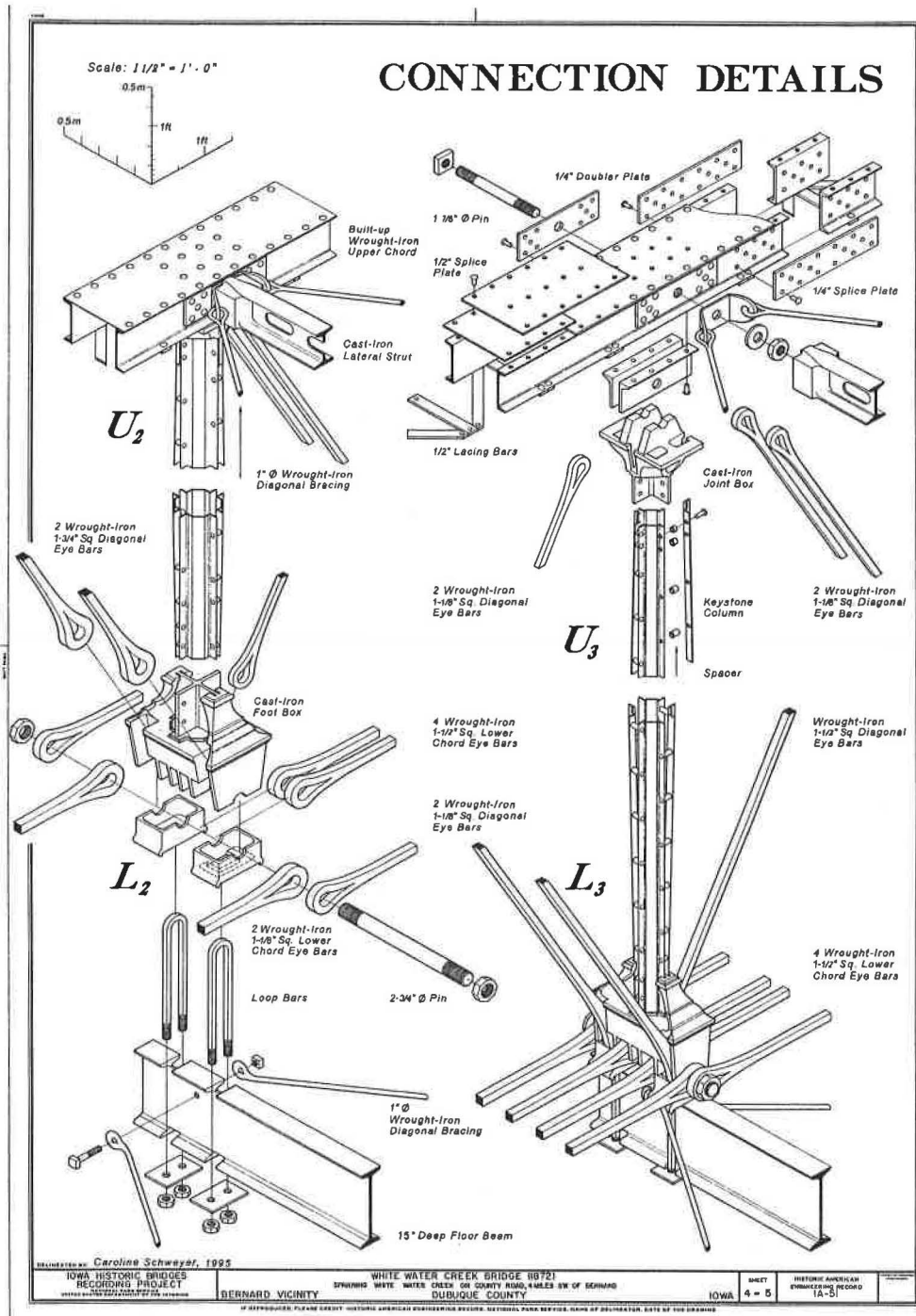
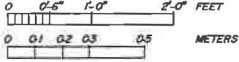

Fig. 8 Historic American Engineering Record drawing, 1995

TABLE OF SECTIONS

SCALE: 2"=1'-0"



UPPER CHORD

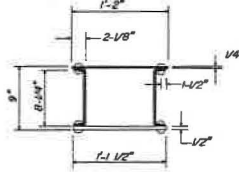

TOP LATERAL BRACING



POSTS

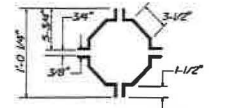

INCLINED END POST, BASE SECTION

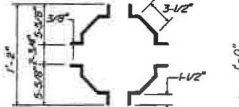

INCLINED END POST, CENTER SECTION

L0-U1
L8-U7

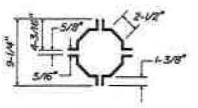

LARGE VERTICAL POST, BASE SECTION

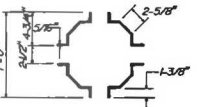

LARGE VERTICAL POST, CENTER SECTION

L2-U2
L5-U6

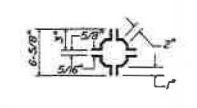

SMALL VERTICAL POST, BASE SECTION

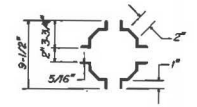

SMALL VERTICAL POST, CENTER SECTION

L3-U3
L4-U4
L5-U5

HIP VERTICAL

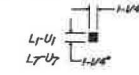

STRUT

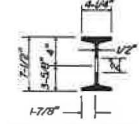

STRUT AT CENTER OF FIRST OPENING FROM UPPER CHORD

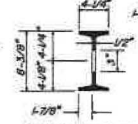

STRUT AT CENTER OF SEVENTH OPENING FROM UPPER CHORD

BOTTOM LATERAL BRACING



DIAGONAL BRACING

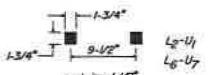

L2-U1
L6-U7

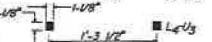

L3-U2
L5-U6



L4-U3
L2-U5
L6-U5

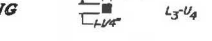

L3-U4
L5-U4

KEY

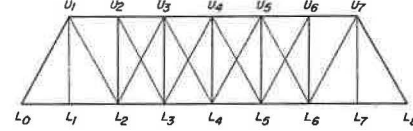

PORTAL BRACING

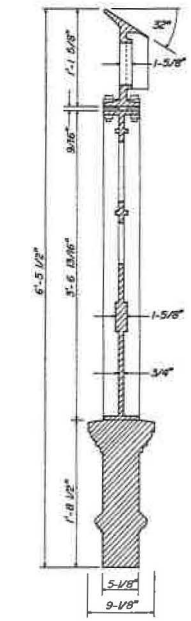

FLOOR BEAM

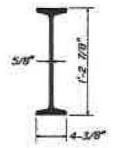

LOWER CHORD

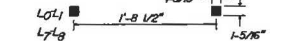

L0-L1
L7-L8



L1-L2
L6-L7



L2-L3
L4-L5



L3-L4
L5-L6



L4-L5
L5-L6

DESIGNED BY: VIRGINIA M. PRICE, B. MANESH, KESWAN, 1996
 IOWA HISTORIC BRIDGES
 BRIDGE NO. 1073
 WHITE WATER CREEK BRIDGE (1073)
 BRIDGE NO. 1073
 DUBUQUE COUNTY
 BERNARD VICTORY

STATE OF IOWA
 HISTORIC ARCHIVES
 ENGINEERING RECORD
 IOWA 5" x 5"
 (A-3)

Fig. 9 Historic American Engineering Record drawing, 1995

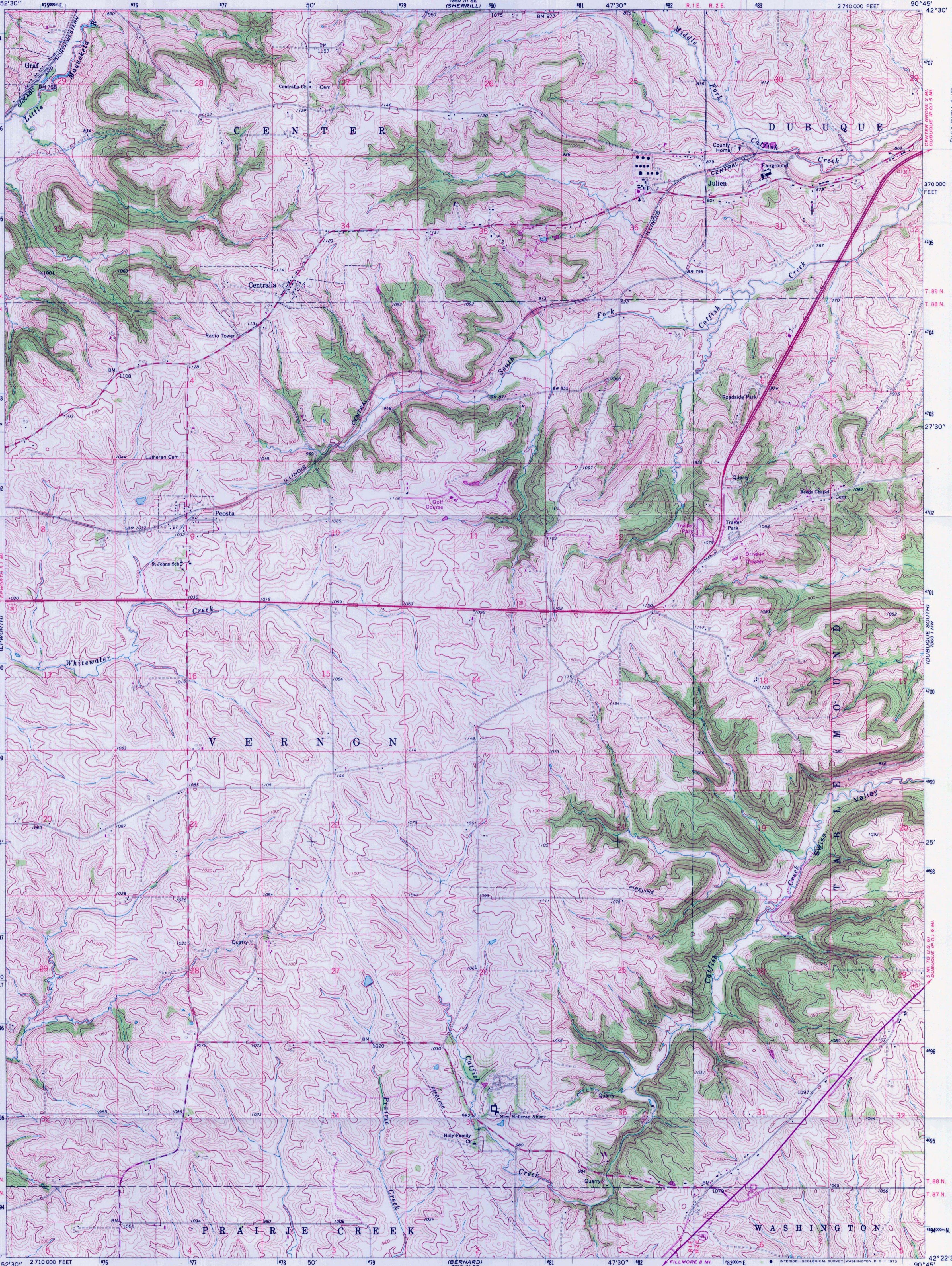

7868 II NW
DUBUQUE NORTH
DUNLEITH AND
DUBUQUE BRIDGE
DUBUQUE COUNTY, IA
UTM: 15, 682920, 4706005

OCT 2 2012

Mapped, edited, and published by the Geological Survey
Control by USGS and USC&GS
Topography by photogrammetric methods from aerial
photographs taken 1964. Field checked 1966
Polyconic projection. 1927 North American datum
10,000-foot grid based on Iowa coordinate system, north zone
1000-meter Universal Transverse Mercator grid ticks,
zone 15, shown in blue
Fine red dashed lines indicate selected fence and field lines where
generally visible on aerial photographs
This information is uncompiled
Revisions shown in purple compiled from aerial photographs
taken 1972. This information not field checked

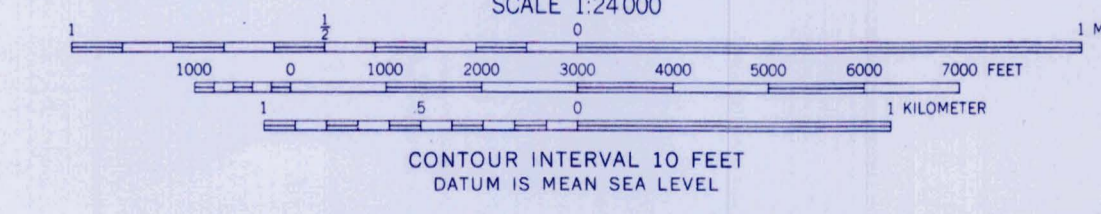
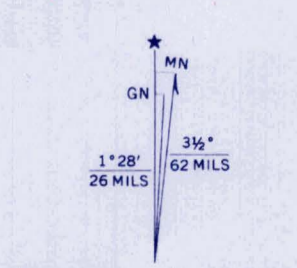

ROAD CLASSIFICATION

Heavy-duty	Light-duty
Medium-duty	Unimproved dirt
U.S. Route	State Route

THIS MAP COMPLIES WITH NATIONAL MAP ACCURACY STANDARDS
FOR SALE BY U.S. GEOLOGICAL SURVEY, DENVER, COLORADO 80225, OR WASHINGTON, D.C. 20242
AND BY THE IOWA GEOLOGICAL SURVEY, IOWA CITY, IOWA 52240
A FOLDER DESCRIBING TOPOGRAPHIC MAPS AND SYMBOLS IS AVAILABLE ON REQUEST

PEOSTA, IOWA
N4222.5-W9045/7.5
1966
PHOTOREVISED 1972
AMS 7868 IV NE-SERIES V876
JUN 13 1973

(FILL MORE)
7868 IV NW

2680





















Dunleith and Dubuque Bridge (Dubuque County, IA)



Dunklethorn Dubuque Bridge Dubuque County, IA

National Register of Historic Places
Memo to File

Correspondence

The Correspondence consists of communications from (and possibly to) the nominating authority, notes from the staff of the National Register of Historic Places, and/or other material the National Register of Historic Places received associated with the property.

Correspondence may also include information from other sources, drafts of the nomination, letters of support or objection, memorandums, and ephemera which document the efforts to recognize the property.

UNITED STATES DEPARTMENT OF THE INTERIOR
NATIONAL PARK SERVICE

NATIONAL REGISTER OF HISTORIC PLACES
EVALUATION/RETURN SHEET

REQUESTED ACTION: NOMINATION

PROPERTY NAME: Dunleith and Dubuque Bridge

MULTIPLE NAME: Highway Bridges of Iowa MPS

STATE & COUNTY: IOWA, Dubuque

DATE RECEIVED: 7/26/13 DATE OF PENDING LIST: 8/16/13
DATE OF 16TH DAY: 9/03/13 DATE OF 45TH DAY: 9/11/13
DATE OF WEEKLY LIST:

REFERENCE NUMBER: 13000690

REASONS FOR REVIEW:

APPEAL: N DATA PROBLEM: N LANDSCAPE: N LESS THAN 50 YEARS: N
OTHER: N PDIL: N PERIOD: N PROGRAM UNAPPROVED: N
REQUEST: Y SAMPLE: N SLR DRAFT: N NATIONAL: N

COMMENT WAIVER: N

ACCEPT RETURN REJECT 9/11/2013 DATE

ABSTRACT/SUMMARY COMMENTS:

This bridge was listed in the National Register in 1998 as the White Water Creek Bridge (NR Reference No. 98000787). The bridge was moved without getting prior National Register approval (as required by NR regulations 36 CFR 60.14 (b)) and was delisted/removed from the National Register on 5/9/2012. The bridge, now named the Dunleith and Dubuque Bridge is nominated on its new site/location.

RECOM./CRITERIA Accept c

REVIEWER Patrick Andrews

DISCIPLINE Historian

TELEPHONE _____

DATE 9/11/2013

DOCUMENTATION see attached comments Y/N see attached SLR Y/N

If a nomination is returned to the nominating authority, the nomination is no longer under consideration by the NPS.



Andrus, Patrick <patrick_andrus@nps.gov>

FW: Dunleith and Dubuque Bridge

2 messages

Foster, Beth [DCA] <Beth.Foster@iowa.gov>
To: "Patrick_Andrus@nps.gov" <Patrick_Andrus@nps.gov>

Thu, Sep 26, 2013 at 12:16 PM

Patrick,

Do you want Clay to send you hard copies of the attached pictures of the bridge?

Beth

Elizabeth Foster Hill

National Register/Tax Incentive Programs Manager

From: cbfraser@aol.com [mailto:cbfraser@aol.com]
Sent: Thursday, September 26, 2013 10:54 AM
To: Foster, Beth [DCA]
Subject: Re: Dunleith and Dubuque BridgeBeth, attached are two views of the bridge with its deck in place. Do you still want me to mail hard copies of these to the Register? If so, can you give me the contact information?
Clay

-----Original Message-----

From: Foster, Beth [DCA] [DCA] <Beth.Foster@iowa.gov>
To: cbfraser <cbfraser@aol.com>
Sent: Thu, Sep 26, 2013 5:56 am
Subject: RE: Dunleith and Dubuque Bridge

Hi Clay,

Could you check on this for me? The review contacted me again.

Beth

Elizabeth Foster Hill

National Register/Tax Incentive Programs Manager

600 E. Locust Street

Des Moines, IA 50319

Beth.Foster@iowa.gov

515/281-4137

FAX 515/282-0502

Hours: Monday – Thursday 6:00 a.m. – 4:00 p.m.

The State Historic Preservation Office will present two workshops in Des Moines next month!

October 17, 2013 - We will focus on the State Tax Credit program. Providing general information about the program and how to complete the forms.

October 18, 2013 - The National Register of Historic Places Workshop will cover how to do research and complete the nomination registration forms.

Information and Registration Forms are available on our website: <http://www.iowahistory.org/historic-preservation/index.html>

- Find information about the National Register and Tax Incentive programs on our website at www.IowaHistory.org, click on Historic Preservation at the top, choose a topic on the left side.
- Want to have your property evaluated to see if it is eligible for the National Register? Complete and send an Iowa Site Inventory form and required materials to me. FAQ <http://www.iowahistory.org/historic-preservation/statewide-inventory-and-collections/frequently-asked-questions.html> - Forms <http://www.iowahistory.org/historic-preservation/statewide-inventory-and-collections/iowa-site-inventory-form.html>
- What are qualified rehabilitation tax credit expenses, <http://www.nps.gov/tps/tax-incentives/before-apply/qualified-expenses.htm>
- Information about IRS requirements for Federal Tax Incentives, <http://www.irs.gov/pub/irs-utl/faqrehab.pdf> - <http://www.nps.gov/tps/tax-incentives/before-apply/irs.htm> - These two websites provide great information for working with the Federal Tax Incentives and the IRS.
- Information on the Federal Tax Incentives from the National Park Service (NPS), <http://www.nps.gov/tps/tax-incentives/before-you-apply.htm>

- View the Federal Tax Incentive Brochure, <http://www.nps.gov/tps/tax-incentives/taxdocs/about-tax-incentives-2012.pdf> - This is very nicely done and one of my favorite quick views.
- How to Preserve Historic Properties, <http://www.nps.gov/tps/how-to-preserve.htm>
- View the NPS Preservation training at, <http://www.nps.gov/tps/education/online-training.htm>
- A link to our statewide inventory collection, specific information on Barns, Movie Theaters and Schools. <http://www.iowahistory.org/historic-preservation/statewide-inventory-and-collections/index.html>

From: cbfraser@aol.com [mailto:cbfraser@aol.com]
Sent: Monday, September 23, 2013 10:01 AM
To: Foster, Beth [DCA]
Subject: Re: Dunleith and Dubuque Bridge

Beth, Dave Johnson in Dubuque says he'll have something to me soon.

—Original Message—

From: Foster, Beth [DCA] [DCA] <Beth.Foster@iowa.gov>
To: CBFRASER <CBFRASER@aol.com>
Sent: Mon, Sep 23, 2013 7:36 am
Subject: Dunleith and Dubuque Bridge

I forgot to paste in the text:

In the Dunleith and Dubuque Bridge nomination, in Section 7, page 1 at the end of the second paragraph it states that timber deck and the guardrails are missing, but that their replacement is "scheduled to occur in late 2012." Has this happened yet, and if so we need to have a photograph showing the bridge with the deck and railings in place.

Hi Clay,

I received the following message from the National Park Service reviewer. We would need to get a photograph to him immediately so he will meet his timeline and not have to send the nomination back. I was thinking we could send one through email, with a hardcopy directly to him.

Beth

Elizabeth Foster Hill
National Register/Tax Incentive Programs Manager
600 E. Locust Street

Des Moines, IA 50319

Beth.Foster@iowa.gov

515/281-4137

FAX 515/282-0502

Hours: Monday – Thursday 6:00 a.m. – 4:00 p.m.

The State Historic Preservation Office will present two workshops in Des Moines next month!

October 17, 2013 - We will focus on the State Tax Credit program. Providing general information about the program and how to complete the forms.

October 18, 2013 - The National Register of Historic Places Workshop will cover how to do research and complete the nomination registration forms.

Information and Registration Forms are available on our website: <http://www.iowahistory.org/historic-preservation/index.html>

- Find information about the National Register and Tax Incentive programs on our website at www.iowaHistory.org, click on Historic Preservation at the top, choose a topic on the left side.
- Want to have your property evaluated to see if it is eligible for the National Register? Complete and send an Iowa Site Inventory form and required materials to me. FAQ <http://www.iowahistory.org/historic-preservation/statewide-inventory-and-collections/frequently-asked-questions.html> - Forms <http://www.iowahistory.org/historic-preservation/statewide-inventory-and-collections/iowa-site-inventory-form.html>
- What are qualified rehabilitation tax credit expenses, <http://www.nps.gov/tps/tax-incentives/before-apply/qualified-expenses.htm>
- Information about IRS requirements for Federal Tax Incentives, <http://www.irs.gov/pub/irs-utl/faqrehab.pdf> - <http://www.nps.gov/tps/tax-incentives/before-apply/irs.htm> - These two websites provide great information for working with the Federal Tax Incentives and the IRS.
- Information on the Federal Tax Incentives from the National Park Service (NPS), <http://www.nps.gov/tps/tax-incentives/before-you-apply.htm>
- View the Federal Tax Incentive Brochure, <http://www.nps.gov/tps/tax-incentives/taxdocs/about-tax-incentives-2012.pdf> - This is very nicely done and one of my favorite quick views.
- How to Preserve Historic Properties, <http://www.nps.gov/tps/how-to-preserve.htm>
- View the NPS Preservation training at, <http://www.nps.gov/tps/education/online-training.htm>
- A link to our statewide inventory collection, specific information on Barns, Movie Theaters and Schools. <http://www.iowahistory.org/historic-preservation/statewide-inventory-and-collections/index.html>

2 attachments

DSC02996.jpg
5012K



DSC03002.jpg
4685K



Andrus, Patrick <patrick_andrus@nps.gov>
To: "Foster, Beth [DCA]" <Beth.Foster@iowa.gov>

Thu, Sep 26, 2013 at 12:34 PM

Hi Beth: Yes, please send them to me and I will add them to the file. Thanks for handling this.

Patrick

[Quoted text hidden]

—
Patrick Andrus, Historian
National Register of Historic Places
National Park Service
(202) 354-2218
patrick_andrus@nps.gov

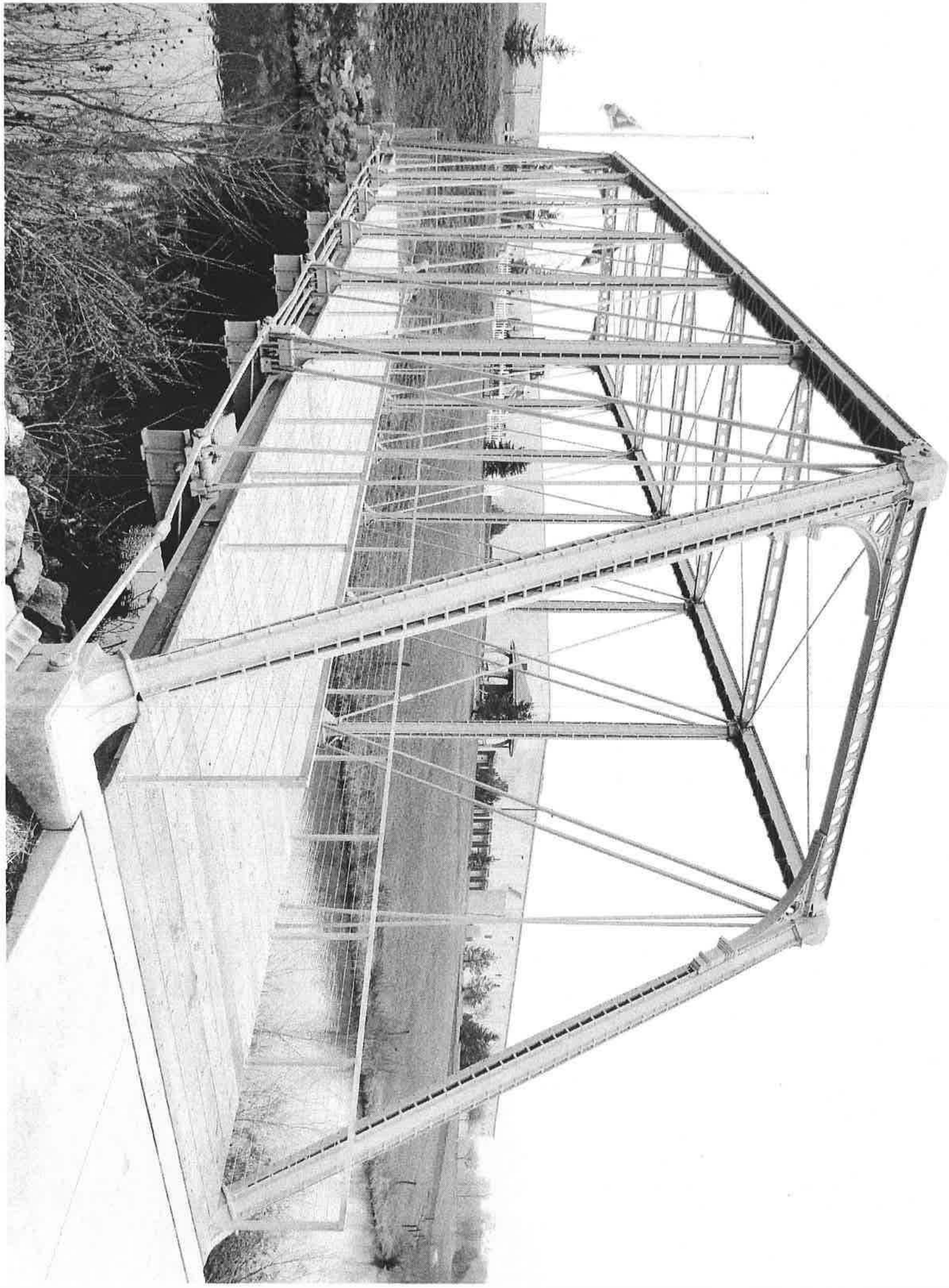

ACTION: NATIONAL REGISTER INFORMATION SYSTEM
Id 98000787 RN 05/09/2012 IA Dubuque White Water Creek Bridge
01 More

Name White Water Creek Bridge
Address Whitewater Rd. over White Water Cr.
City Bernard Vicinity X Restrict
State IOWA County Dubuque
Status REMOVED FROM NATIONAL REGISTER Date 05/09/2012
Day45 Resource Type STRUCTURE Acreage 0.9
Multiple Highway Bridges of Iowa MPS
Contributing bldg 0 Site 0 Strc 1 Obj 0 Total 1
Noncontributing bldg 0 Site 0 Strc 0 Obj 0 Total 0
Park

Moved in 1989

• Listed in 1998

• Removed in 2012 after unapproved move.

• Nominated at new location 2013

as the Dunleith and Dubuque Bridge (NR Ref:# 13000690)

IOWA DEPARTMENT OF

CULTURAL AFFAIRS

MARY TIFFANY COWNIE, DIRECTOR

TERRY E. BRANSTAD, GOVERNOR

KIM REYNOLDS, LT. GOVERNOR



STATE
HISTORICAL
SOCIETY of
IOWA

JEROME THOMPSON
ADMINISTRATOR



MATTHEW HARRIS
ADMINISTRATOR

600 E. LOCUST
DES MOINES, IOWA
50319

T. (515) 281-5111
F. (515) 282-0502

CULTURALAFFAIRS.ORG

July 23, 2013

Carol Shull, Chief
National Park Service
National Register of Historic Places
1201 Eye Street, N.W.-- 8th Floor
Washington, D.C. 20005

Dear Ms. Shull:

The following National Register nomination(s) are enclosed for your review and listed if acceptable.

- B Avenue NE Historic District, Cedar Rapids, Linn County, Iowa
- Dunleith and Dubuque Bridge, Dubuque, Dubuque County, Iowa

Sincerely,

Elizabeth Foster Hill, Manager
National Register and Tax Incentive Programs