

United States Department of the Interior  
National Park Service

National Register of Historic Places  
Registration Form

This form is for use in nominating or requesting determinations for individual properties and districts. See instructions in *How to Complete the National Register of Historic Places Registration Form* (National Register Bulletin 16A). Complete each item by marking "x" in the appropriate box or by entering the information requested. If an item does not apply to the property being documented, enter "N/A" for "not applicable." For functions, architectural classification, materials, and areas of significance, enter only categories and subcategories from the instructions. Place additional entries and narrative items on continuation sheets (NPS Form 10-900a). Use a typewriter, word processor, or computer, to complete all items.

1. Name of Property

historic name North Carolina Industrial Home for Colored Girls

other names/site number Efland Home

2. Location

street & number 201 Redman Crossing

N/A not for publication

city or town Efland

vicinity

state North Carolina

code NC

county Orange

code 135

zip code 27243

3. State/Federal Agency Certification

As the designated authority under the National Historic Preservation Act, as amended, I hereby certify that this  nomination  request for determination of eligibility meets the documentation standards for registering properties in the National Register of Historic Places and meets the procedural and professional requirements set for in 36 CFR Part 60. In my opinion, the property  meets  does not meet the National Register criteria. I recommend that this property be considered significant  nationally  statewide  locally. (See continuation sheet for additional comments.)

Kevin Cherry, SHPO  
Signature of certifying official/Title

11/28/2017  
Date

North Carolina Department of Natural and Cultural Resources  
State or Federal agency and bureau

In my opinion, the property  meets  does not meet the National Register criteria. ( See Continuation sheet for additional comments.)

\_\_\_\_\_  
Signature of certifying official/Title

\_\_\_\_\_  
Date

\_\_\_\_\_  
State or Federal agency and bureau

4. National Park Service Certification

I hereby certify that the property is:

- entered in the National Register.
  - See continuation sheet
- determined eligible for the National Register.
  - See continuation sheet
- determined not eligible for the National Register.
- removed from the National Register.
- other, (explain:) \_\_\_\_\_

[Signature]  
Signature of the Keeper

\_\_\_\_\_  
Date of Action

1-25-2018

North Carolina Industrial Home for Colored Girls  
Name of Property

Orange County, NC  
County and State

**5. Classification**

**Ownership of Property**  
(Check as many boxes as apply)

- private
- public-local
- public-State
- public-Federal

**Category of Property**  
(Check only one box)

- building(s)
- district
- site
- structure
- object

**Number of Resources within Property**  
(Do not include previously listed resources in count.)

Contributing	Noncontributing	
1	1	buildings
0	0	sites
0	0	structures
0	0	objects
1	1	Total

**Name of related multiple property listing**  
(Enter "N/A" if property is not part of a multiple property listing.)

N/A

**Number of Contributing resources previously listed in the National Register**

N/A

**6. Function or Use**

**Historic Functions**  
(Enter categories from instructions)

DOMESTIC: Institutional Housing  
\_\_\_\_\_  
\_\_\_\_\_  
\_\_\_\_\_  
\_\_\_\_\_  
\_\_\_\_\_  
\_\_\_\_\_

**Current Functions**  
(Enter categories from instructions)

DOMESTIC: Single Dwelling  
\_\_\_\_\_  
\_\_\_\_\_  
\_\_\_\_\_  
\_\_\_\_\_  
\_\_\_\_\_  
\_\_\_\_\_

**7. Description**

**Architectural Classification**  
(Enter categories from instructions)

Craftsman  
\_\_\_\_\_  
Classical Revival  
\_\_\_\_\_  
\_\_\_\_\_  
\_\_\_\_\_  
\_\_\_\_\_  
\_\_\_\_\_

**Materials**  
(Enter categories from instructions)

foundation BRICK  
walls SYNTHETICS: Vinyl  
\_\_\_\_\_  
\_\_\_\_\_  
roof METAL  
\_\_\_\_\_  
other \_\_\_\_\_  
\_\_\_\_\_

**Narrative Description**

(Describe the historic and current condition of the property on one or more continuation sheets.)

8. Statement of Significance

Applicable National Register Criteria

(Mark "x" in one or more boxes for the criteria qualifying the property for National Register listing.)

- Criteria A, B, C, D with checkboxes and descriptions.

Criteria Considerations

(Mark "x" in all the boxes that apply.)

Property is:

- Criteria A, B, C, D, E, F, G with checkboxes and descriptions.

Areas of Significance

(Enter categories from instructions)

Ethnic Heritage: Black
Social History

Period of Significance

1925-1939

Significant Dates

1925

Significant Person

(Complete if Criterion B is marked)

N/A

Cultural Affiliation

African American

Architect/Builder

Unknown

Narrative Statement of Significance

(Explain the significance of the property on one or more continuation sheets.)

9. Major Bibliographical References

Bibliography

(Cite the books, articles, and other sources used in preparing this form on one or more continuation sheets.)

Previous documentation on file (NPS):

- Criteria for previous documentation on file.

Primary location of additional data:

- Criteria for primary location of additional data.

Name of repository:

North Carolina State Archives, Raleigh

North Carolina Industrial Home for Colored Girls  
Name of Property

Orange County, NC  
County and State

### 10. Geographical Data

Acreage of Property 2.4 acres

#### UTM References

(Place additional UTM references on a continuation sheet.)

See continuation sheet

1	Zone	Easting	Northing	3	Zone	Easting	Northing
2				4			

See continuation sheet

#### Verbal Boundary Description

(Describe the boundaries of the property on a continuation sheet.)

#### Boundary Justification

(Explain why the boundaries were selected on a continuation sheet.)

### 11. Form Prepared By

name/title Heather Fearnbach  
organization Fearnbach History Services, Inc. date July 18, 2017  
street & number 3334 Nottingham Road telephone 336-765-2661  
city or town Winston-Salem state NC zip code 27104

#### Additional Documentation

Submit the following items with the completed form:

#### Continuation Sheets

#### Maps

A **USGS map** (7.5 or 15 minute series) indicating the property's location

A **Sketch map** for historic districts and properties having large acreage or numerous resources.

#### Photographs

Representative **black and white photographs** of the property.

#### Additional items

(Check with the SHPO or FPO for any additional items.)

#### Property Owner

(Complete this item at the request of SHPO or FPO.)

name Mary E. Grant and Virginia Wise  
street & number PO Box 145 telephone 919-625-5040  
city or town Mebane state NC zip code 27302

**Paperwork Reduction Act Statement:** This information is being collected for applications to the National Register of Historic Places to nominate properties for listing or determine eligibility for listing, to list properties, and to amend existing listing. Response to this request is required to obtain a benefit in accordance with the National Historic Preservation Act, as amended (16 U.S.C. 470 *et seq.*)

**Estimated Burden Statement:** Public reporting burden for this form is estimated to average 18.1 hours per response including time for reviewing instructions, gathering and maintaining data, and completing and reviewing the form. Direct comments regarding this burden estimate or any aspect of this form to the Chief, Administrative Services Division, National Park Service, P. O. Box 37127, Washington, DC 20013-7127; and the Office of Management and Budget, Paperwork Reductions Projects (1024-0018), Washington, DC 20303.



United States Department of the Interior  
National Park Service

# National Register of Historic Places Continuation Sheet

Section number 7 Page 1 North Carolina Industrial Home for Colored Girls  
Orange County, NC

## Section 7. Narrative Description

### Setting

The North Carolina Industrial Home for Colored Girls (NCIHCG) stands 617 feet south of Redman Crossing on a long, narrow, 2.4-acre lot in Efland, a rural community in west Orange County's Cheeks Township. Efland is situated between Hillsborough, approximately six miles to the east, and Mebane, four miles to the west in neighboring Alamance County. U. S. Highway 70 and a railroad line, both of which are north of and parallel Redman Crossing, connect the municipalities. The North Carolina Railroad commenced service on the track, part of its inaugural 223-mile route between Charlotte and Goldsboro, on January 21, 1856. Norfolk Southern Railway Company now operates the line.<sup>1</sup> Interstate 40/85, also an east-west corridor, is south of the NCIHCG tract.

Redman Crossing extends south from U. S. Highway 70 and then becomes an east-west corridor. At the road's east end, a straight, gravel, north-south drive leads to the NCIHCG, where it encircles a grass median north of the cottage. Although landscape plantings are minimal, some deciduous and evergreen trees and shrubs line the building foundation and ornament the grass lawn. A frame pavilion with a low-side-gable roof supported by square wood posts rests on a poured-concrete slab west of the median. A small, late-twentieth-century, front-gable-roofed, concrete-block, noncontributing pump house stands slightly northeast of the pavilion. East of the NCIHCG, at the edge of the woods, a series of chain-link enclosures covered with tarps serve as dog kennels. A prefabricated, gambrel-roofed metal shed and a ruinous frame gazebo stand on the rear yard's south perimeter. Like the frame pavilion, these minor, insubstantial resources do not merit counting.

An institution intended to rehabilitate young African American women convicted of minor infractions operated at this site from late October 1925 until March 15, 1939. The tract initially encompassed 143 acres, a portion of which the previous owner had cleared and planted with tobacco and other crops. The flat topography and rich soil made it ideal for farming. Reformatory residents continued to cultivate approximately forty acres. U. S. Department of Agriculture aerial photographs illustrate field patterns and crop rotation practices. In 1938, sizable fields north, west, and south of the house were planted, while the southwest field was fallow. Wooded areas and windbreaks bordered the fields. In 1955, the southwest field was in use and the other fields were fallow. The location and appearance of any outbuildings is unclear from the aerials, but the farm likely included a barn, chicken house, hog pen, and well house. By 1975, the area surrounding the dwelling was densely wooded.<sup>2</sup>

<sup>1</sup> North Carolina Railroad Company, "NCRH History," <http://www.ncrr.com/about-ncrr/ncrr-history/> (accessed March 2017).

<sup>2</sup> U. S. Department of Agriculture, aerial photographs, AJV-9-43 (1938), 6P-32 (1955), 176-78 (1975), North Carolina Office of Archives and History; Raleigh, North Carolina, accessed through University of North Carolina-Chapel Hill's GIS Services at <http://library.unc.edu/services/data/gis-usda/orange> (February 2017).

United States Department of the Interior  
National Park Service

# National Register of Historic Places Continuation Sheet

Section number 7 Page 2 North Carolina Industrial Home for Colored Girls  
Orange County, NC

Although large agricultural and wooded tracts remain, residential and commercial development has encroached upon the rural setting. Modest dwellings, many of which are mid- to late- twentieth-century Minimal Traditional and Ranch houses, flank U. S. Highway 70. The most significant intrusion has been the 2016 construction of a solar farm on the parcel immediately west of the residual NCIHCG tract. A tall, screened-chain-link fence and a buffer of deciduous and evergreen trees and shrubs mitigate the visual impact.

## North Carolina Industrial Home for Colored Girls, 1925, contributing building

The one-story, frame, roughly T-shaped building consists of a hip-roofed, seven-bay-wide main block and a three-part rear wing. The cottage faces north toward Redman Crossing. The wing encompasses a half-hip-roofed north section that extends from the main block's center, a gable-roofed offset south section, and a shed-roofed enclosed porch and pantry at the gabled section's south end.

The seven-bay north elevation encompasses a central entrance flanked by three evenly-spaced, original, tall, six-over-six, double-hung, wood sash. Double-track aluminum storm windows were installed in the late twentieth century. A gabled entrance porch with late-twentieth-century square wood posts shelters a late-twentieth-century, single-leaf, six-raised-panel, wood door and a five-pane wood-frame sidelight. Two groups of three square posts on short plinths initially supported the porch. The original door's appearance is not clear from a circa 1926 photograph, but a rendering indicates that it was double-leaf with square base panels and multi-pane upper sections.<sup>3</sup>

A late-twentieth-century wood railing secures the porch and the deck that extends west across the façade. Matching railings flank two sets of three wood steps that lead to the porch and deck. Wide wood boards sheath the porch and deck floor. The late-twentieth-century concrete-block exterior chimney on the north elevation east of the porch vents a heating stove.

Two shed dormers with one-over-one, double-hung, aluminum sash pierce the north roof slope. The original pressed-metal-shingle roof is substantially intact. The weatherboards and soffits have been covered with vinyl siding and gutters mounted on the once-exposed rafter ends. The dwelling rests on a continuous painted-brick foundation. The large multi-pane sash, symmetrical façade, and no-longer-extant grouped porch posts are Classical Revival stylistic elements, while the massing, hip roof, weatherboarded exterior, exposed rafter ends, and shed dormers reflect a Craftsman influence.

---

<sup>3</sup> The photograph appeared in two North Carolina State Board of Charities and Public Welfare publications: *Biennial Report of the North Carolina State Board of Charities and Public Welfare, 1924-26* (Raleigh: NCSBCPW, 1926), p. 120, and *North Carolina's Social Welfare Program for Negroes*, Special Bulletin Number 8, Raleigh, 1926, p. 37. The rendering was included in a circa 1930 fundraising brochure, *North Carolina State Board of Public Welfare Institutions and State Charitable, Penal, and Correctional Institutions* (hereafter abbreviated NCSBPWI), Box 163, North Carolina State Archives, Raleigh.

United States Department of the Interior  
National Park Service

## National Register of Historic Places Continuation Sheet

Section number   7   Page   3   North Carolina Industrial Home for Colored Girls  
Orange County, NC

The west elevation comprises three main block bays, three rear wing bays, and single enclosed porch bay. Three original, tall, six-over-six, double-hung, wood sash illuminate the main block. The rear wing's half-hip-roofed north section contains a shorter pair of six-over-one, double-hung, wood sash, while two single windows with the same configuration illuminate the gable-roofed south section. A square brick heating-stove chimney pierces the north section's west roof slope. A short, one-over-one, double-hung, aluminum sash has been installed on the enclosed porch's west wall.

The rear wing interrupts the center of the main block's south wall. Single, tall, six-over-six, double-hung, wood sash pierce the wall just east and west of the wing. The square brick chimney near the south elevation's east end vented a heating stove.

The shed-roofed projection that spans the south section's gable end initially encompassed an open porch in its west two-thirds and a pantry at its east end. The pantry is intact, but the porch has been enclosed to create a utility room. Near the south elevation's west end, a six-panel vinyl door accessed by four concrete-block steps and an open dimensional lumber railing opens into the utility room. A short, one-over-one, double-hung, aluminum sash is east of the door. The pantry retains a single six-over-six, double-hung, wood sash on its south wall.

The pantry's west wall is blind. A single six-over-six, double-hung, wood sash illuminates the rear wing's south section. A square brick cook-stove chimney rises from the south section's east roof slope. The rear wing's north section initially contained a pair of six-over-six, double-hung, wood sash, but the lower sash of the south window has been replaced with a single-pane sash. The north section projects further east than the south section, allowing room for a single window on its south wall.

The main block's east elevation differs from its west elevation in that the south windows are paired. Additionally, a square brick heating-stove chimney rises on the south side of the single north window.

### Interior

The floor plan reflects the building's multi-purpose use in conjunction with its operation as a reformatory. Such edifices, designed to accommodate residential, administrative, and educational functions, were often historically called "cottages." North Carolina State Board of Charities and Public Welfare field agent T. L. Grier inspected the institution in July 1937. He delineated the functions of the rooms at that time as an office, superintendent's bedroom, matron's bedroom, "living-hall" for classes and recreation, eight-person dormitory, two four-person bedrooms, one-person detention room, bathroom, dining room, kitchen, and pantry. He noted that furnishings and kitchen and dining room fittings were minimal and a wood cook stove fueled the hot water heater. The living

United States Department of the Interior  
National Park Service

## National Register of Historic Places Continuation Sheet

Section number 7 Page 4 North Carolina Industrial Home for Colored Girls  
Orange County, NC

room contained amenities such as a piano and a radio as well as a table and chairs. The girls slept on single iron beds.<sup>4</sup>

The main block's first story comprises a central living room/classroom and six flanking rooms of various sizes. Simple, intact interior finishes include plaster walls and ceilings, flat-board door and window surrounds, tall baseboards, and molded picture rails. Tongue-and-groove pine floors are exposed in most rooms. The utilitarian finishes reflect the institution's minimal construction budget.

Each original single-leaf door has a square lower and a rectangular upper panel. Closet doors are narrower than room entrance doors. Original door hinges remain but passage knobs have been replaced with modern brass locks. Original metal closet door knobs and escutcheons have been painted. The few late-twentieth-century single-leaf wood doors have six raised panels.

The front door opens directly into the spacious irregularly shaped living room/classroom's northwest corner. The wood heating stove to the east on the north elevation was a late-twentieth-century addition. Inadequate flashing between the stove chimney and the wall has resulted in extensive plaster damage. The frame wall that encloses the straight run of stairs that rises on the living room's east wall to the second story was a late-twentieth-century modification.

The small room between the living room and the northwest bedroom may have served as the office. A molded picture rail wraps around the walls approximately six inches below the ceiling. A double-leaf folding closet door was recently installed on the south wall.

The two-bay deep southwest room, which is the largest space other than the living room, was likely the eight-person dormitory. This room has a simple molded cornice. A door at the south wall's east end provides access to the dining room in the rear wing.

The northeast bedroom is two bays wide and one bay deep. An original shallow closet with a narrow single-leaf door is located on the south wall. The floor slopes to the southeast due to partial joist failure.

South of the stair to the second story, a short east/west corridor leads to two small bedrooms; one on its south side and the other at the corridor's east end. Frame partition walls and single-leaf, hollow-core, flat-panel doors have been added to create two closets on the corridor's north side. The east bedroom has a small original closet on its north elevation. The west bedroom retains a molded picture rail. A door on its south wall leads to the bedroom at the rear wing's northeast corner.

---

<sup>4</sup> W. C. Ezell and T. L. Grier, "The North Carolina Home for Colored Girls, Efland, NC," site visit report, July 2, 1937, NCSBPWI, Box 163, North Carolina State Archives, Raleigh.



United States Department of the Interior  
National Park Service

## National Register of Historic Places Continuation Sheet

Section number 7 Page 5 North Carolina Industrial Home for Colored Girls  
Orange County, NC

At the living room's southeast corner, west of the southwest bedroom, an enclosed stair leads to the basement furnace room, which is usually flooded. The area west of the stair contains entrances to the southwest dormitory and the dining room. The rectangular, pressed-metal, ceiling-mounted lantern that illuminates the vestibule may be original.

A late-twentieth-century raised six-panel door separates the living room/classroom and the dining room, which has been embellished with a late-twentieth-century molded chair rail and cornice. Gypsum board sheathes the heating stove chimney between the living room/classroom and southwest dormitory entrances. The raised six-panel door on the east wall opens into what was a bedroom as well as the solitary detention room. The frame partition walls enclosing the closet at the room's northeast corner were a late-twentieth-century addition. Sheet vinyl covers the floor. The only original bathroom is at the bedroom's south end. The fixtures have been replaced and a square ceramic tile floor installed.

The kitchen was updated in the late twentieth century with a molded chair rail and cornice, wood cabinets with paneled doors at its northeast corner, a large central island, and square ceramic floor tiles. The simple, wood, two-door base cabinet on the south wall may date to the reformatory period. The stove chimney has been enclosed with gypsum board and the stove removed. A late-twentieth-century raised six-panel door at the south wall's east end provides access to an original pantry lined with wood shelves. The pantry occupies the east bay of what was the rear shed porch. The pantry and the former open porch, now a utility room, have square ceramic tile floors. A late-twentieth-century raised six-panel door separates the kitchen and utility room.

The stairs that lead from the living room to the second story terminate at an east-west corridor with a low, sloped, plaster ceiling and a kneewall on its south elevation. A full bathroom was added between the stair and the east bedroom in the late twentieth century. Two small bedrooms are west of the stair. The bedrooms are simply finished with plaster walls, hollow-core flat-panel doors, and commercial-grade carpeting.

### **Pump House, third quarter of the twentieth century, noncontributing building**

A small front-gable-roofed concrete-block pump house stands northwest of the residence. A wide vertical-board door on the east elevation provides interior access. Painted plywood sheathes the gables. The building is noncontributing due to its age.

### **Integrity Statement**

NCIHCG possesses the seven qualities of historic integrity—location, setting, feeling, association, design, materials, and workmanship—required for National Register designation. The dwelling maintains integrity of location as it stands on its original site south of Redman Crossing. Although the



United States Department of the Interior  
National Park Service

# National Register of Historic Places Continuation Sheet

Section number   7   Page   6   North Carolina Industrial Home for Colored Girls  
Orange County, NC

original 143-acre tract has been subdivided and some commercial and residential development undertaken, the entrance drive is in its original location and the area south and east of the house remains wooded. The most significant intrusion has been the 2016 construction of a solar farm on the parcel immediately west of the residual NCIHCG tract. A tall, screened-chain-link fence and a buffer of deciduous and evergreen trees and shrubs mitigate the visual impact. The residual 2.4 acres associated with the dwelling is sufficient to convey its rural character, thus allowing for integrity of setting, feeling, and association.

NCIHCG also retains integrity of design, materials, and workmanship. The frame cottage displays a typical early-twentieth-century form—a hip-roofed main block and a gabled rear wing—as well as original six-over-six, double-hung, wood-sash and a pressed-metal shingle roof. Simple, intact interior finishes include plaster walls and ceilings, molded picture rails, paneled doors, and flat board door surrounds and baseboards. Tongue-and-groove pine floors are exposed in most rooms. The utilitarian finishes reflect the institution's minimal construction budget. Late-twentieth-century modifications such as the installation of aluminum storm windows, vinyl siding, replacement front porch elements, and the deck west of the porch are reversible.

## Archaeology Potential Statement

The reformatory is closely related to the surrounding environment and landscape. Archaeological remains, such as trash deposits, wells, and other structural remains which may be present can provide information valuable to the understanding and interpretation of the NCIHCG. Information concerning institutional culture and African American identity, as well as the spatial organization of outdoor activities and the character of daily life at the reformatory, can be obtained from the archaeological record. Therefore, archaeological remains may well be an important component of the reformatory's significance. At this time no investigation has been done to discover these remains, but it is likely that they exist, and this should be considered in any development of the property.

United States Department of the Interior  
National Park Service

# National Register of Historic Places Continuation Sheet

Section number 8 Page 7 North Carolina Industrial Home for Colored Girls  
Orange County, NC

## Section 8. Statement of Significance

North Carolina Industrial Home for Colored Girls (NCIHCG) meets National Register of Historic Places Criterion A for its statewide significance in social history and African American ethnic history. Beginning in late 1919, prominent educator and North Carolina Federation of Colored Women's Clubs' president Charlotte Hawkins Brown of Palmer Memorial Institute led a campaign to sponsor a reformatory for African American girls. The North Carolina General Assembly had established a statewide juvenile court system that year and sentencing often mandated reformatory placement. However, the North Carolina State Board of Charities and Public Welfare did not operate a reformatory for African American girls until 1944, leaving private entities and religious and fraternal organizations to subsidize rehabilitation efforts.

Brown and other club leaders garnered support from black and white chapters of the Federation of Women's Clubs, philanthropists, churches, businesses, and charitable and fraternal organizations to fund NCIHCG's construction and operation in the west Orange County community of Efland. The facility, which comprised a cottage and farm, admitted its first residents in October 1925 and provided academic instruction as well as agricultural and domestic skills training for up to twenty youth at a time. NCIHCG, the first known facility of its kind for African American girls in North Carolina, served a statewide constituency and was one of only ten comparable institutions for African American girls throughout the United States in 1930. Despite the demonstrated need for such a facility, administrative and financial challenges resulted in the reformatory's closure on March 15, 1939. The period of significance begins with the cottage's 1925 completion and continues to 1939.

### North Carolina Industrial Home for Colored Girls History

Prominent African American women including Ida Bell Wells-Barnett, Frances E. W. Harper, Josephine St. Pierre Ruffin, Harriet Tubman, Mary Church Terrell, and Margaret Murray Washington led efforts to combat disenfranchisement during the Jim Crow era. With other activists, community leaders, and educators, they founded the National Association of Colored Women (NACW) in 1896. The organization consolidated the National Federation of Afro-American Women, the Women's Era Clubs of Boston, and the Colored Women's League of Washington, D.C. Members promoted initiatives to ameliorate disparities in child care, education, housing, medical treatment, prisons, social welfare, and transportation. NACW's mantra, "lifting as we climb," recognized the uphill battle that African Americans faced in a segregated culture.<sup>5</sup>

---

<sup>5</sup> National Association of Colored Women's Clubs, "Who Are We," <http://www.nacwc.org/aboutus/index.html> (accessed January 2017); Anne Firor Scott, "Most Invisible of All: Black Women's Voluntary Associations," *The Journal of South History*, Vol. 56, No. 1 (February 1990), 12-13.

United States Department of the Interior  
National Park Service

## National Register of Historic Places Continuation Sheet

Section number 8 Page 8 North Carolina Industrial Home for Colored Girls  
Orange County, NC

NACW incorporated as the National Association of Colored Women's Clubs (NACWC) in 1904. Supporters created statewide associations with local chapters to facilitate NACWC's mission. The North Carolina Federation of Colored Women's Clubs (NCFCWC), founded in 1909, was one of twenty-eight NACW federations in 1914. NACWC membership had by then grown to fifty thousand, distributed among over one thousand clubs. Members partnered with African American and white philanthropists, churches, businesses, and charitable and fraternal organizations to subsidize programs and institutions that met community needs.<sup>6</sup>

The North Carolina Federation of Women's Clubs (NCFWC), established in 1902, frequently collaborated with its sister African American organization. By 1918, approximately seven thousand white club women orchestrated initiatives throughout the state under the leadership of president Kate Burr Johnson. NCFWC's Social Service Department successfully advocated for the creation of the State Home and Industrial School at Samarcand Manor, a Moore County reformatory for delinquent white girls that opened in 1918. The organization supported the founding of a similar institution for young African American women through political lobbying and financial contributions.<sup>7</sup>

Beginning in 1919, NCFCWC president Charlotte Hawkins Brown led a concerted campaign to construct such a reformatory. In a series of newspaper appeals and public addresses, she emphasized that delinquent African American girls were particularly vulnerable and woefully underserved by public welfare programs. The institution would provide academic and vocational instruction in a safe and nurturing environment, thus imbuing the young women with the skills they needed to succeed.<sup>8</sup> The timing was opportune, as it coalesced with the North Carolina General Assembly's mandate for a statewide juvenile court system and county public welfare boards that year.

Brown, a highly regarded educator, was the founder and head of Palmer Memorial Institute, a private school in Sedalia that had served African American youth since 1902. Her management experience was critical to the nascent reformatory's success. The NCFCWC also benefited from guidance provided by leaders of similar institutions. Brown and other NCFCWC members visited Virginia Industrial Home for Colored Girls, established in 1915 by the Virginia State Federation of Colored Women's Clubs and led by Janie Porter Barrett.<sup>9</sup> Brown recruited her colleague Mary McLeod

<sup>6</sup> Scott, "Most Invisible of All," 16-17.

<sup>7</sup> Clara I. Cox, ed., *The North Carolina Federation of Women's Clubs Yearbook, 1917-1918* (High Point: North Carolina Federation of Women's Clubs, 1918), 78-79; "Negro Club Women Commended," *Asheville Citizen-Times*, April 25, 1926, p. 50.

<sup>8</sup> Charlotte Hawkins Brown, correspondence, 1919, NCSBPWI, Box 163; "State Reformatory for Negro Youth," *Asheville Citizen-Times*, November 3, 1919, p. 10; Charlotte Hawkins Brown, "To the Colored Women of North Carolina," *Charlotte Observer*, May 23, 1921, p. 6; "Federation Raises Thousand Dollars," *Daily Advance*, August 8, 1922, p. 1; "Campaign for Salvaging Wayward Colored Girls," *Charlotte Observer*, November 3, 1922, p. 3; "Colored Women Back Industrial Home Plan," *Asheville Citizen-Times*, March 22, 1924, p. 8.

<sup>9</sup> Charlotte Hawkins Brown, correspondence, 1921, NCSBPWI, Box 163.

United States Department of the Interior  
National Park Service

## National Register of Historic Places Continuation Sheet

Section number 8 Page 9 North Carolina Industrial Home for Colored Girls  
Orange County, NC

Bethune, who had in 1904 established Daytona Educational and Industrial Training School for Negro Girls (Bethune-Cookman University since 2007) in Daytona Beach, Florida, to solicit donations for the North Carolina reformatory and participate in fundraising efforts. In Bethune's keynote speech at NCFWC's annual meeting in 1925, she urged attendees to continue the fight for equitable facilities and opportunities for African American youth.<sup>10</sup>

NCFWC identified a 143-acre farm in Efland, approximately four miles east of Mebane, as an optimal location for the girls' reformatory. The site was easily accessible and had the added benefit of being only twenty-eight miles east of Palmer Memorial Institute. NCFWC paid S. C. and Carrie Forrest \$7,150 for the two-parcel tract on July 16, 1921. The Forrests had been cultivating tobacco on the property and retained ownership of their tobacco sticks and flues as well as all planted crops that had yet to be harvested that year. NCFWC conveyed the acreage to NCIHCG trustees on August 3, 1922.<sup>11</sup>

NCFWC elected a distinguished board of trustees with valuable professional and personal connections to implement the reformatory's mission. The 1925 roster included Charlotte Hawkins Brown and other leaders from across the state who had campaigned for the institution's creation. Honorary chair Fannie Bickett of Raleigh, who was white, was a powerful ally due to her roles as a NCFWC officer, Wake County's superintendent of public welfare, and the widow of North Carolina governor and social welfare program advocate Thomas Walter Bickett. Chair Minnie G. Pearson of Durham was married to Hillside Park High School principal and businessman William G. Pearson, who functioned as the board's "special treasurer." Maude B. Cotton's husband John A. Cotton pastored a Henderson congregation. Ophelia T. Griffin was a teacher at High Point Normal and Industrial School, where her husband Alfred J. Griffin served as principal from 1897 until 1923. Lula S. Kelsey and her husband William F. Kelsey operated a Salisbury funeral home. Lillian V. Mebane was a public school teacher in Rocky Mount.<sup>12</sup>

---

<sup>10</sup> Bethune had a North Carolina connection as she attended Scotia Seminary as a scholarship recipient from 1888 through 1893. She founded the National Council for Negro Women in 1935; served as the first African American female federal agency head—Director of the Division of Negro Affairs of the National Youth Administration—from 1936 until 1944; and led civil rights initiatives until her death in 1955. National Council of Negro Women, Inc., "Mary McLeod Bethune," <http://ncnw.org/about/bethune.htm>. (accessed February 2017); "Mary McLeod Bethune, 1875-1955," [http://www.nps.gov/mamc/learn/historyculture/people\\_marymcleodbethune.htm](http://www.nps.gov/mamc/learn/historyculture/people_marymcleodbethune.htm) (accessed February 2017); "North Carolina Federation Women Held 16<sup>th</sup> Annual Session, Mrs. Brown, Pres.," *New York Age*, May 30, 1925, p. 2.

<sup>11</sup> Orange County Deed Book 80, p. 48; Deed Book 81, p. 5.

<sup>12</sup> William Pearson was instrumental in the founding of Mechanics and Farmers Bank, North Carolina Mutual Life Insurance Company, Fraternal Bank and Trust Company, Southern Fidelity and Surety Company, Bankers Fire Insurance Company, and the National Religious Training School and Chautauqua (now North Carolina Central University). Charlotte Hawkins Brown, undated financial statement, NCSBPWI, Box 163; U. S. Censuses, Population Schedules, 1900-1940; R. McCants Andrews, *John Merrick: A Biographical Sketch* (Durham: Seeman Printery, 1920), 52-57.



United States Department of the Interior  
National Park Service

## National Register of Historic Places Continuation Sheet

Section number 8 Page 10 North Carolina Industrial Home for Colored Girls  
Orange County, NC

Although it took several years, the NCFWC solicited almost \$30,000 in private donations to allow for the reformatory's construction and operation. In May 1925, at its annual meeting held in Wilson, the organization celebrated the completion of a one-story, weatherboarded, hip-roofed cottage erected by contractors including James Henry Liner at a cost of approximately \$4,600. The building contained a central living room/classroom, dormitory-style bedrooms, matrons' quarters, bathroom, dining room, kitchen, and basement furnace room. Painter S. P. Cheek charged \$225. NCFWC purchased household goods at Davis Furniture Company, Myers Department Store, and cots, mattresses, and pillows at Mebane Bedding Company. NCFWC's Durham chapter, led by women including Julia Warren and Annie Day Shepard, subsidized the living room furnishings. Home Light and Power Company of Greensboro constructed and equipped a small pump and Delco generator house for \$836.50. Well and septic tank installation cost an additional \$405. Efland merchant S. C. Forrest drilled the well, provided hardware and supplies, and held the mortgage on the house and land.<sup>13</sup>

NCIHCG's architect has not been identified. Charlotte Hawkins Brown notes in her September 5, 1921 letter to North Carolina State Board of Charities and Public Welfare (NCSBCPW) commissioner Kate Burr Johnson that plans for a cottage estimated to cost \$5,000 were being drawn. The finely executed line drawing on the cover of NCIHCG's circa 1930 fundraising brochure indicates a design professional's involvement. The cottage was erected as rendered with the exception of the wall sheathing material, which, due to budget constraints, was weatherboard rather than brick. The principal contractor James Henry Liner (1888-1959), who lived north of Efland in the rural Cedar Grove community, would have been capable of adapting the preliminary plans as needed. Liner's skill is apparent in his work for the Orange County Board of Education, for which he built the one-story brick St. Mary's School (1931) in Hillsborough.<sup>14</sup>

NCIHCG admitted its first residents in October 1925 under the supervision of matron Carrie M. Brooks, teacher Rosa Morrow, and farm manager Charles Fuller. Brooks, an educator who had previously resided in Greensboro and Washington, D. C., accepted a year-long contract with a \$900 salary. She prepared for the position by working in July and August at the Virginia Industrial Home for Colored Girls, where she received guidance from Janie Porter Barrett.<sup>15</sup>

Like many comparable institutions, the NCIHCG included a farm that provided residents with sustenance and exercise. Agricultural returns reported to 1925 North Carolina farm census taker A. K.

<sup>13</sup> "North Carolina Federation Women Held 16<sup>th</sup> Annual Session, Mrs. Brown, Pres.," *New York Age*, May 30, 1925, p. 2; NCSBCPW, *Biennial Report of the NCSBCPW, 1924-1926* (Raleigh: NCSBCPW, 1926), 120-121; Charlotte Hawkins Brown, undated report and financial statement, NCSBPWI, Box 163.

<sup>14</sup> Charlotte Hawkins Brown, correspondence, 1921, and NCIHCG financial statements, NCSBPWI, Box 163; Orange County Board of Education minutes, November 12, 1930, microfilm, North Carolina State Archives, Raleigh; death certificate.

<sup>15</sup> Charlotte Hawkins Brown, correspondence and reports, NCSBPWI, Box 163.



United States Department of the Interior  
National Park Service

## National Register of Historic Places Continuation Sheet

Section number 8 Page 11 North Carolina Industrial Home for Colored Girls  
Orange County, NC

McAdams indicate that the farm manager, children, and staff cultivated 33 acres of corn, tobacco, wheat, cotton, and Irish potatoes. No livestock are listed, but within a year pigs, chickens, and dairy cows provided meat, eggs, milk, butter, and cheese.<sup>16</sup>

North Carolina's juvenile court system had placed twelve young women at the reformatory by 1926. Under matron Mary E. Hill's direction, the NCIHCG served thirty juveniles between July 1, 1926, and June 30, 1928. During that time, one youth was released to a "working home," two to hospitals, three to relatives, and seven ran away, leaving seventeen on site. Occupancy typically exceeded the reformatory's fifteen-person capacity. Residency remained about the same over the course of 1928-1929, when fifteen girls were paroled and eleven discharged to working homes. Hill was well-qualified for her position, as she had previously held a relief matron position at the Virginia Industrial Home for Colored Girls. However, budget limitations and minimal staffing hampered her efforts.<sup>17</sup>

During the 1928-1929 reporting period, the girls attended classes led by assistant matron Margaret Cromwell, who was not a professionally trained teacher. She earned forty dollars per month. Residents cultivated ten acres and twenty-four fruit trees and tended a mule, two cows, two pigs, four hogs, and one hundred chickens. The farm's production reduced the reformatory's operational cost, which was estimated to be approximately \$598.60 per child in 1928 but dropped to \$182.50 per resident in 1929. Recreational activities included playing basketball, croquet, and jumping rope. The girls and staff attended Sunday worship services and prayer meetings at a local church. Mebane physician Thomas David Tyson made house calls as needed.<sup>18</sup>

NCFCWC continued to pursue state financing and management, but was not successful. However, the organization secured a \$2,000 appropriation from the state in 1927. Thereafter, yearly subsidies fluctuated from \$1,375 to \$2,000 between 1928 and early 1939. Annual operating expenses ranged from about \$3,600 to \$8,000.<sup>19</sup>

NCIHCG was one of only ten comparable institutions for African American girls throughout the United States in 1930. Most had been founded in the twentieth century's first decades and served as models for Charlotte Hawkins Brown and other NCFCWC leaders as they planned NCIHCG. Private entities operated the Dorcas Home (1914) in Houston, Texas; Fairwold Industrial School for Colored Girls (1919) in Columbia, South Carolina; Girls' Rescue Home (1921) in Mt. Meigs, Alabama; and

---

<sup>16</sup> North Carolina Department of Agriculture, Statistics Division, Farm Census Reports, 1925, Box 24 (Onslow-Pasquotank Counties), North Carolina State Archives, Raleigh.

<sup>17</sup> NCSBCPW, *Biennial Report of the NCSBCPW, 1925-1926*, 120-121; "Annual Reports, NCIHCG, 1928 and 1929," NCSBPWI, Box 163; Virginia Industrial Home for Colored Girls, *Fifth Annual Report of the Industrial Home for Colored Girls*, 1920.

<sup>18</sup> "Annual Reports, NCIHCG, 1928 and 1929," NCSBPWI, Box 163.

<sup>19</sup> *Ibid.*

United States Department of the Interior  
National Park Service

## National Register of Historic Places Continuation Sheet

Section number 8 Page 12 North Carolina Industrial Home for Colored Girls  
Orange County, NC

Florida Industrial Home for Colored Girls (1921) in Ocala. The Industrial Home for Colored Girls (1882) in Melvale, Maryland, a private facility, received state and city subsidies. Publicly funded and run facilities included Industrial Home for Negro Girls (1909) in Tipton, Missouri; Virginia Industrial Home for Negro Girls (1915) in Peak's Turnout; Industrial School for Colored Girls (1920) in Marshallton, Delaware; and Oklahoma Industrial School for Colored Girls (1920) in Taft.<sup>20</sup>

NCIHCG served a statewide constituency. Eighteen residents in 1930 were from Buncombe, Carteret, Durham, Forsyth, Guilford, Mecklenburg, Pasquotank, Robeson, Vance, and Wake counties, with the largest number (five) coming from Durham County. All had been committed by juvenile court order. The three-person staff included interim superintendent Marie Clay Clinton of Charlotte, appointed in December 1929, her assistant Bertha Vincent, and a local man who guided the farm's operation. Staff oversaw academic instruction as well as agricultural and domestic skills training. Clinton, a forty-five-year-old widow, had garnered some experience working with youth through NCFCWC initiatives, but was not a social worker or teacher. Therefore, Vincent, a thirty-two-year-old Scotia Seminary graduate, led academic classes. Both women served as house mothers and taught food preparation and preservation, laundry, and sewing.<sup>21</sup>

Residents participated in a wide variety of activities. The girls shared one sewing machine and sewed by hand, fabricating clothing, handkerchiefs, a quilt, sofa pillows, and other items. Classes were held during the mornings and afternoons during the winter, when there were fewer outdoor chores to complete. The remainder of the year, residents often studied in the mornings, worked outside in the afternoons, and reconvened for academic instruction in the evenings. Most of the young women had limited prior scholastic experience. This factor, coupled with disparities in age and aptitude, resulted in a rudimentary curriculum. The girls and the farm manager cut wood; cultivated corn, wheat, and vegetables; and tended chickens, pigs, and dairy cows. In spring 1930, Lindley Nurseries donated seventy-five fruit trees and twenty-five grape vines that University of North Carolina students planted for NCIHCG.<sup>22</sup>

Farm production supplemented meager rations. Residents assisted with meal preparation and service. Breakfast was typically hash, grits, and bread. One additional meal was provided in the winter and two in seasons that required significant physical labor. These meals often comprised white beans, bacon, and corn bread, or macaroni and tomatoes. In 1930, dining room furnishings included two oilcloth-covered tables, chairs, and a dish-washing sink. Plates, forks, spoons, serving dishes, and cooking

---

<sup>20</sup> Margaret Reeves, *Training Schools for Delinquent Girls* (New York: Russell Sage Foundation, 1929); Wiley Britton Sanders, *Negro Child Welfare in North Carolina: A Rosenwald Study* (Chapel Hill: University of North Carolina Press, 1933), 50.

<sup>21</sup> Clinton later served as NCFCWC's president. Sanders, *Negro Child Welfare in North Carolina*, 51; United States Census, Population Schedule, 1930; "Co-Laborers in a Grand Task," *Federation Journal*, May 1, 1952, p. 4.

<sup>22</sup> Sanders, *Negro Child Welfare in North Carolina*, 55.

United States Department of the Interior  
National Park Service

## National Register of Historic Places Continuation Sheet

Section number 8 Page 13 North Carolina Industrial Home for Colored Girls  
Orange County, NC

utensils were extremely limited in quantity. There were only four knives and no cups, bowls, glasses, napkins, or table clothes.<sup>23</sup>

Religious instruction was an important element of NCIHCG's curriculum. NCFCWC promoted achieving spiritual awareness as a core component of a healthy lifestyle. A local pastor and NCIHCG staff conducted worship services. Residents were asked to pray several times daily. It was hoped that Christian doctrine would inspire good behavior, thus reducing the need for disciplinary measures, which included privilege loss and solitary confinement in the room adjacent to the bathroom.<sup>24</sup>

The institution continued to operate in the same manner during the early 1930s. John Henry Blue and his wife superintended NCIHCG in 1931-1932, assisted by a second matron. Agricultural production remained consistent, with forty acres under cultivation. Beef, pork, chicken, eggs, milk, butter, fruit, and vegetables from the farm augmented the residents' diet.<sup>25</sup>

Minnie Pearson succeeded Charlotte Hawkins Brown as NCFCWC president in 1934. NCFCWC and NCSBCPW continued to petition the General Assembly to assume NCIHCG's oversight. Residency averaged around fifteen young women annually between 1932 and 1934, during which time superintendents included J. H. Blue, Sadie F. Powell, and J. A. Lassiter. State Board of Public Welfare field agent W. C. Ezell noted a need for additional classroom space during a February 1934 inspection. At that time, the dining room also functioned as a classroom. Powell was then the only adult in residence.<sup>26</sup>

J. A. Lassiter, a certified teacher, replaced Powell as matron in May 1934. Her husband oversaw the farm's operation. That year, the girls cultivated fields, canned fruit and vegetables, sewed clothes and bedding, and made cornhusk mattresses, baskets, rag rugs, and other household items. They received free medical care at the African American Lincoln Hospital in Durham, where NCIHCG sponsor and trustee Julia Warren's husband, obstetrician Stanford Lee Warren, had been a founding trustee. Cottage improvements included painting the porch floor and posts, oiling the interior wood floors, and installing curtains and oilcloth table covers. Benefactors donated cash, a picnic lunch, and items such as clothing, food, magazines, and a radio.<sup>27</sup>

---

<sup>23</sup> Ibid., 54.

<sup>24</sup> Ibid., 56.

<sup>25</sup> NCSBCPW, *Biennial Report of the North Carolina School for Negro Girls for the Two Years Ended June 30, 1932*, 396-398, NCSBPWI, Box 163.

<sup>26</sup> "Mrs. Pearson Named Head of N. C. Clubs," *Pittsburgh Courier*, May 19, 1934, p. 8; "Annual Reports, NCIHCG, 1928 and 1929," Box 163

<sup>27</sup> NCSBCPW, *Biennial Report of the North Carolina State Board of Charities and Public Welfare, 1932-1934* (Charlotte: Observer Printing House, 1934), 55, 75; "Annual Reports, NCIHCG, 1928 and 1929," NCSBPWI, Box 163; Andrews, *John Merrick*, 49.

United States Department of the Interior  
National Park Service

## National Register of Historic Places Continuation Sheet

Section number 8 Page 14 North Carolina Industrial Home for Colored Girls  
Orange County, NC

Mr. Lassiter was dismissed in March 1935. In June 1935, agent Ezell reported that twelve girls were in residence under the supervision of matron Lula B. Henderson and farm manager Lewis Walker, both of whom had been hired in April. Henderson's husband, a retired pastor, resided in Chapel Hill but was engaged by the Emergency Relief Administration's Division of Adult Education to provide academic instruction at NCIHCG. Ezell noted that Lula Henderson had called Sheriff Sloan to diffuse altercations on several occasions. He also stated that general store proprietor S. C. Forrest and Rob Nichols asserted that a white man had been assisting runaways from the reformatory. In response to the poor evaluation and other complaints regarding the institution's deficient management, the NCIHCG board of directors' executive committee convened in Durham in July to address the situation. They soon engaged Hilda C. Allen to serve as the reformatory's superintendent. Henderson continued as a matron.<sup>28</sup>

In November 1935, Allen requested that NCSBCPW's Division of Mental Health evaluate the reformatory and propose improvement measures. The study, which included intelligence and scholastic aptitude tests, concluded that most residents suffered from mental impairments which led to difficulties with academic coursework that were exacerbated by a lack of books and supplies. Vocational instruction was therefore encouraged, with the idea that domestic skills training would better prepare the girls to find work after discharge. The inspector also found that the facility's single bathroom, heating system, and water supply were inadequate. The kitchen stove was the primary heat source as the basement flooded every winter, rendering the furnace inoperable. The pump was often out of commission, making it impossible to draw water from the well. Site staff did not have an administrative office. The inspector encouraged resolution of these issues as well as interior painting and decorating to provide a more pleasant environment. Also, as all of the windows had been covered with barbed wire to discourage runaways, the agent suggested removing the wire.<sup>29</sup>

Hilda Allen solicited contributions from individuals and organizations in order to affect some of the proposed changes. She taught the girls to sing spirituals and arranged performances of the Efland Quartette at local churches as a means of promoting the reformatory's success and garnering donations. Allen made considerable progress in her efforts to improve conditions. However, citing an inability to manage her numerous duties, she resigned in early May 1937, leaving Lula Henderson in charge.<sup>30</sup>

W. C. Ezell and his assistant T. L. Grier inspected the institution in July 1937. They noted ongoing issues with the heating system, bathroom, and overall building repair. Henderson, farm manager Charlie Freeman, and the residents struggled to maintain the cottage and agricultural operation. The

<sup>28</sup> NCSBCPW correspondence, 1935, NCSBPWI, Box 163.

<sup>29</sup> NCSBCPW Division of Mental Health, "Psycho-educational Survey of North Carolina Industrial School for Negro Girls," 1935, NCSBPWI, Box 163.

<sup>30</sup> Hilda C. Allen, letter to R. Eugene Brown, April 29, 1937, NCSBPWI, Box 163.



United States Department of the Interior  
National Park Service

## National Register of Historic Places Continuation Sheet

Section number 8 Page 15 North Carolina Industrial Home for Colored Girls  
Orange County, NC

farm comprised about twenty acres of hay, corn, peas, sweet potatoes, vegetables. Equipment included tools, plows, a wagon, a mowing machine, and a mule harness. A small barn and a corn crib were in good condition, but the livestock was not. The sole cow had recently died, the hog and four pigs were thin, and one mule was crippled and the other difficult to handle. Only a few chickens remained. Due to these conditions, and the fact that the institution provided inadequate care and rehabilitation, Grier concluded that the facility was completely ineffective in its mission. He recommended that the NCFCWC board either increase funding enough to remedy the situation or close the reformatory.<sup>31</sup>

The institution persevered. In January 1938, Lula Henderson reported on successful work placements for former residents in Mebane and Greensboro, North Carolina; Washington, D. C.; and Seneca, South Carolina. Community members and churches contributed to the campus's operational costs. Patrons supplied clothing, shoes, hats, soap, towels, candy, canned goods, apples, and fabric and notions for dressmaking. However, donations were not sufficient to suitably maintain the facility or to provide basic necessities for its residents. After University of North Carolina at Chapel Hill field work director George H. Lawrence visited in April, he reported to NCSBCPW director J. Wallace Nygard that the reformatory conditions were so appalling that "the place is worse than useless." He suggested that the girls would be better served in a county jail, where they would at least receive adequate sustenance. NCSBCPW Division of Negro Work director William R. Johnson met with NCFCWC board members, and in October 1938 they decided to cease operations in five months. Between October 1925 and the reformatory's March 15, 1939 closure, the institution housed more than two hundred girls. While commendable, the reformatory was able to serve of only a small fraction of the 3,839 African American girls under the age of sixteen whose cases came before juvenile courts during the 1920s and 1930s.<sup>32</sup>

The use of the Efland property from 1939 through the 1950s is unknown. It is likely that NCIHCG leased the cottage to a series of tenants and the acreage to the lessees or local farmers. A 1955 U. S. Department of Agriculture aerial photograph indicates that fields were still being cultivated during that period.<sup>33</sup> NCIHCG trustees sold the Efland property to W. G. Fields Jr. and his wife Nannette, investors who remained Chapel Hill residents, on April 29, 1957. The Fields subdivided a portion of the land west of the cottage to create eight tracts spanning the distance between Redman Crossing and Interstate 40. Each parcel encompassed between four-and-one-half and twelve acres. Edwards Realty Company acquired the twelve-acre tract No. 1, which included the cottage, on November 17, 1958 and conveyed it to Mack and Lina Lee Stout on September 22, 1959. They sold the cottage and 2.4

<sup>31</sup> W. C. Ezell and T. L. Grier, "The North Carolina Home for Colored Girls, Efland, NC," site visit report, July 2, 1937, NCSBPWI, Box 163.

<sup>32</sup> "The Efland Home," *Carolina Times*, February 4, 1939; Undated overview of NCIHCG funding history, "The Need for a State Training School for Delinquent Negro Girls," and "Annual Reports, North Carolina Industrial Home for Colored Girls, 1928 and 1929," NCSBPWI, Box 163.

<sup>33</sup> U. S. Department of Agriculture, aerial photograph, 6P-32 (1955).



United States Department of the Interior  
National Park Service

## National Register of Historic Places Continuation Sheet

Section number 8 Page 16 North Carolina Industrial Home for Colored Girls  
Orange County, NC

surrounding acres to an African American couple, James Nills Graham, known as Nello, and Myrtle McAdoo Graham, in December 1959. James and Myrtle had both grown up on Efland farms. James, a United States Army veteran, died on July 15, 1974. Myrtle passed away on March 9, 1987. The Grahams attended White Cross A. M. E. Church, where they are interred.<sup>34</sup>

The Grahams' son James Barnard Graham, a Vietnam War veteran, obtained title to the house and 2.4 acres on December 14, 1984. He died on July 15, 2010. Mary E. Grant purchased the tract on November 13, 2013, following an auction held in conjunction with Graham's estate settlement.<sup>35</sup>

### Social History Context: North Carolina Juvenile Welfare Institutions

During the seventeenth, eighteenth, and nineteenth centuries, colonial and North Carolina courts often placed children whose parents were deceased or unable to serve as guardians in apprenticeships intended to result in mastery of a marketable trade and basic literacy. Early settlers, many of whom immigrated from England, Germany, Scotland, and Ireland, supported this approach as it had been a common practice in their countries of origin. Group residences for penurious youth were rare. In the nineteenth century's second decade the North Carolina General Assembly incorporated a few short-lived organizations such as the Newbern Female Charitable Society (1812) and the Female Orphan Asylum of Fayetteville (1813). However, it was not until 1868 that legislators created a government entity to provide statewide social welfare assistance. The five-member Board of Public Charities' first act was to inventory jails and poorhouses, but its purview soon grew to include oversight of hospitals, convict camps, and homes for veterans, elderly, and infirm citizens. Although ameliorating the hardship of destitute youth was part of the board's mandate, it did not subsidize orphanages. Private organizations thus solicited donations to facilitate indigent child care.<sup>36</sup>

In February 1873, the Grand Lodge of the Order of Free Masons established Oxford Orphan Asylum, North Carolina's first permanent institution created to house and educate white orphans. Admittance was based upon need rather than familial ties to Masons. Although the endeavor was privately funded, the institution later received small state appropriations to aid its operation. The orphanage's first superintendent, John Haymes Mills, left Oxford in 1884 to found the state's second orphanage in Thomasville.<sup>37</sup>

<sup>34</sup> Orange County Deed Book 163, p. 39; Deed Book 169, p. 85; Plat Book 8, p. 3; Deed Book 173, p. 140.

<sup>35</sup> Orange County Deed Book 494, p. 453; Deed Book 4985, p. 161; Deed Book 5720, p. 388.

<sup>36</sup> Arthur E. Fink, "Changing Philosophies and Practices in North Carolina Orphanages," *North Carolina Historical Review*, Volume 48, Number 4, October 1971, 333-336; "First Annual Report of the Board of Public Charities," Document No. 26, *Executive and Legislative Documents Laid Before the General Assembly of North Carolina, Session 1869-1870* (Raleigh: John W. Holden, printer, 1870), 2-4.

<sup>37</sup> Fink, "Changing Philosophies and Practices in North Carolina Orphanages," 337.

United States Department of the Interior  
National Park Service

## National Register of Historic Places Continuation Sheet

Section number 8 Page 17 North Carolina Industrial Home for Colored Girls  
Orange County, NC

Two African American residents of Henderson, North Carolina—public school teacher Henry Plummer Cheatham and Baptist church pastor Augustus Shepard—partnered with twelve other black leaders to create Grant Colored Asylum, the first orphanage for African American children in North Carolina. Donations from churches and individuals subsidized the 1883 purchase of a twenty-three-acre farm one-and-one-half miles south of Oxford in Granville County and the renovation of a small house and barn on the property. The facility functioned as Grant Colored Asylum until March 28, 1887, when it incorporated as the Colored Orphan Asylum of North Carolina. That year, the institution's board of directors elected Reverend Robert L. Shepard to serve as superintendent. In 1892, the African American Grand Lodge of Masons of North Carolina pledged a recurring donation equal to ten per cent of its annual gross receipts. The following year, the North Carolina General Assembly delineated a \$2,500 appropriation to subsidize the orphanage's operation. The amount increased over time.<sup>38</sup>

Churches and fraternal organizations managed ten sizable orphanages statewide by 1899. Facility administration typically comprised a board of directors and a superintendent who was often a minister in institutions overseen by religious denominations. The wives of married superintendents or a chief matron assisted with daily management, along with teachers, house parents, and staff, most of whom lived on campus. Orphanages provided academic instruction as well as training in agricultural, domestic, and vocational pursuits. Children executed tasks such as cooking, cleaning, laundering, farming, food preservation, and building and grounds maintenance. Although their labor greatly reduced annual operating costs, orphanages struggled to be self-supporting.<sup>39</sup>

The Colored Orphan Asylum of North Carolina (NR 1988) epitomized this paradigm. Reverend Shepard superintended the institution until 1907. Henry Plummer Cheatham, a former slave, educator, and United States congressman (1889-1893), then headed the Granville County campus, overseeing until his death in 1935 a broad campus improvement program that involved replacing frame buildings with edifices erected with brick manufactured by students. State funding allowed for the 1915 completion of the two-story, brick, Italianate-style building that bears Cheatham's name and contained a chapel, dining room, kitchen, and classroom. Other brick structures included girls' and boy's dormitories, an infants' cottage, a laundry, and a smokehouse.<sup>40</sup>

<sup>38</sup> North Carolina Department of the Secretary of State, "Colored Orphan Asylum of North Carolina," <http://www.secretary.state.nc.us/Search/profcorp/4905941> (accessed January 2015); "Colored Orphanage Office Building Is Erected on Campus," *Oxford Public Ledger*, June 15, 1934; "History of the Colored Orphanage of North Carolina," 1935 document from Central Children's Home of North Carolina, Inc., files; The Duke Endowment, *Twelfth Annual Report*, August 1937, 87-88.

<sup>39</sup> Fink, "Changing Philosophies and Practices in North Carolina Orphanages," 337, 339, 351.

<sup>40</sup> A March 20, 1948, fire destroyed the boys' dormitory, which was replaced the next year. North Carolina Mutual Life Insurance Company, "'A 'Charitable Object' Becomes a Monument to the Development of Negro Youth,'" *The Whetstone*, fourth quarter 1964; Marvin A. Brown and Patricia Esperon, "Central Orphanage," National Register of Historic Places nomination, 1987.

United States Department of the Interior  
National Park Service

## National Register of Historic Places Continuation Sheet

Section number 8 Page 18 North Carolina Industrial Home for Colored Girls  
Orange County, NC

Social welfare experts promoted the idea that domestic-scale group residences benefited indigent youth at the first annual White House Conference on the Care of Dependent Children, convened by President Theodore Roosevelt in Washington, D. C., on January 25, 1909. Attendees included African American educator Booker T. Washington, who headed Tuskegee Institute in Alabama; Jane Addams, who in 1889 founded the Chicago social settlement Hull House; journalist and photographer Jacob Riis; and nurse and humanitarian Lillian Wald. Although these and other reformers favored adoption and home boarding over institutional care for destitute children, the group's recommendations to improve orphanage conditions included construction of cottages to be administered by house parents. A cottage atmosphere allowed for more personalized attention with the goal of fostering well-adjusted and productive individuals.<sup>41</sup>

The North Carolina State Board of Charities and Public Welfare (NCSBCPW), created in 1917, endorsed the cottage system as the ideal arrangement for institutions dedicated to child care. In this model, modest-sized buildings provided sleeping quarters for twenty to thirty youth and their caretakers, recreational areas, kitchens, dining rooms, and bathrooms. The cottages' small scale was intended to promote a nurturing domestic atmosphere. The board also encouraged the hiring of a home economics teacher and a physical education director at each institution.<sup>42</sup>

NCSBCPW, which expanded the purview of the Board of Public Charities, had five bureaus: county organization, institutional supervision, child welfare, mental health and hygiene, and promotion and publicity. The Public Welfare Act of 1917 allowed for the creation of county boards of public welfare, which facilitated the state agency's mission. Two years later, additional legislation made county boards mandatory. NCSBCPW evaluated public and privately funded entities that cared for underprivileged children annually to ensure that the facilities offered residents adequate accommodation, education, and supervision.<sup>43</sup>

Stonewall Jackson Training School (NR 1984) near Concord in Cabarrus County was North Carolina's first completely state-subsidized institution established to rehabilitate delinquent children. The General Assembly allocated construction and operation funds in 1907. Two years later, the facility commenced serving white boys younger than sixteen committed to residency by the juvenile court system. The children lived in small cottages with matrons and teachers and received academic instruction up to the eighth-grade level as well as vocational training in carpentry, printing, and

---

<sup>41</sup> John E. B. Myers, *Child Protection in America: Past, Present, and Future* (New York: Oxford University Press, 2006), 58-59; Matthew A. Crenson, *Building the Invisible Orphanage: A Prehistory of the American Welfare System* (Cambridge, M. A.; Harvard University Press, 1998), 11-12.

<sup>42</sup> NCSBCPW, *Biennial Report of the NCSBCPW, 1920-1922*, 22.

<sup>43</sup> University of North Carolina Extension Division, *Public Welfare and the Community*, Vol. IV, No. 10 (Chapel Hill: University of North Carolina Press, 1925), 10-11, 16-17.

United States Department of the Interior  
National Park Service

## National Register of Historic Places Continuation Sheet

Section number 8 Page 19 North Carolina Industrial Home for Colored Girls  
Orange County, NC

shoemaking. In addition to cultivating crops and tending livestock on the 631-acre farm, which included dairy cows and chickens, the boys learned to bake, cook, can, clean, and launder as they assisted with cottage upkeep. Basketball and baseball teams provided an athletic outlet and taught skills such as good sportsmanship and equitable play. The school's population grew to approximately five hundred within twenty years.<sup>44</sup>

State Home and Industrial School at Samarcand Manor in Moore County employed the same pedagogical approach. Beginning in 1918, young white women under the age of twenty-one resided in cottages where they learned domestic skills such as cooking, cleaning, laundering, sewing, weaving, and basket and hat-making. Teachers served as house mothers and led first through tenth-grade-level academic classes, as well as musical and athletic training. The girls planted and harvested fields encompassing approximately three-fifths of the 382-acre farm and raised chickens, pigs, and dairy cows. Residents were either admitted to the school by court order or by voluntary application and remained until reaching the age of eighteen or being discharged. The institution had more than three hundred occupants by the 1930s.<sup>45</sup>

Despite the fact that the North Carolina General Assembly's 1919 establishment of a statewide juvenile court system had resulted in more reformatory placements, there were no state-run institutions to rehabilitate African American delinquents. Orphanages served many at-risk youth, but did not typically accept those who had committed legal infractions. However, such institutions served as models as planning for African American reformatories ensued. Resident teachers typically educated first- through sixth- or seventh-grade students on site, but in some cases all children attended local public schools. In 1922, NCSBCPW evaluated three child-care facilities for black youth: the Colored Baptist Orphanage in Winston-Salem, the Colored Orphanage of North Carolina near Oxford in Granville County, and the Mary Lee Home for Dependent Children operated by Mary Lee Byerly in High Point. In addition to the licensed orphanages, many other child-care facilities operated throughout the state. Most served white children, but in 1922 NCSBCPW inspected and declined to license four African American child-care facilities: the Industrial Union Training School and Orphanage in Southern Pines, the National Nazarene Institute for Advancement of the Race in Greensboro, the Negro Family Orphanage in Wake Forest, and Mary Elizabeth Moore's school in Hiddenite.<sup>46</sup>

In 1924, NCSBCPW and the University of North Carolina at Chapel Hill received a grant from the Laura Spelman Rockefeller Memorial Fund that subsidized a pilot demonstration program designed to advance African American welfare. Sponsors hoped that the initiative, launched on January 1, 1925,

---

<sup>44</sup> NCSBCPW, *Brief History of the Care of the Under-Privileged Child in North Carolina*, Special Bulletin Number 13 (Raleigh, 1934), 28-29.

<sup>45</sup> *Ibid.*, 29.

<sup>46</sup> NCSBCPW, *Biennial Report of the NCSBCPW, 1920-1922*, 19, 23.



United States Department of the Interior  
National Park Service

## National Register of Historic Places Continuation Sheet

Section number 8 Page 20 North Carolina Industrial Home for Colored Girls  
Orange County, NC

would become a model for other state-wide systems. Staff explored methods to facilitate equitable access to education, health care, housing, and recreational facilities for the state's black residents under the auspices of the newly created Division of Negro Work. Seven African American leaders including Charlotte Hawkins Brown and Winston-Salem Teachers College president Simon G. Atkins served on the division's state-wide advisory commission. NCSBCPW commissioner Kate Burr Johnson, who had in 1921 become the nation's first female state commissioner of public welfare and North Carolina's first female state department head, appointed African American educator and community leader Lawrence A. Oxley to serve as the division's director. Oxley, a Massachusetts native and World War I veteran, had been a social sciences instructor at St. Augustine's College in Raleigh since 1920. His early division work benefited from connections made while in that position.<sup>47</sup>

Oxley orchestrated the Wake County Department of Public Welfare's implementation of the state's first county-wide African American social work program. This involved appointing an advisory committee of local black leaders and establishing nineteen township committees. Each group was charged with soliciting funds from individuals, churches, schools, and fraternal organizations to subsidize public welfare projects.<sup>48</sup>

NCSBCPW's mission to establish a reformatory for delinquent male African American youth that would foster "self-reliance, initiative, and the ability to think and act intelligently" was finally realized in 1925. In January of that year, the juvenile court system began paroling young men to Morrison Training School in Hoffman, Richmond County. Construction had commenced in 1924 following a \$25,000 1923 appropriation by the North Carolina legislature. Four buildings stood on almost three hundred acres by 1926. An expansive two-story-on-basement brick edifice encompassed administrative offices, classrooms, a reception hall, an assembly room, the superintendent's quarters, and dormitories. Approximately seventy-five boys initially received academic and agricultural instruction. Within ten years, almost two hundred youth cultivated crops and tended pigs, chickens, and dairy cows on a four hundred-acre farm. State appropriations for physical plant improvements totaled about \$150,000 through 1932.<sup>49</sup>

NCIHCG, the comparable institution for African American girls, opened with great aspirations in October 1925. However, due to limited funding and staffing, NCFWC struggled to supply residents with adequate sustenance, instruction, and oversight. The privately operated reformatory differed dramatically from its state-run counterparts in size, budget, and management. The facility received no

---

<sup>47</sup> NCSBCPW, *Biennial Report of the NCSBCPW, 1924-1926*, 104-105; William S. Powell, ed., *Dictionary of North Carolina Biography, Volume 4* (Chapel Hill: University of North Carolina Press, 1991), 415; Jeffrey J. Crow, Paul D. Escott, and Flora J. Hatley, *A History of African-Americans in North Carolina* (Raleigh: North Carolina Department of Cultural Resources, 1992), 136-137.

<sup>48</sup> NCSBCPW, *Biennial Report of the NCSBCPW, 1924-1926*, 104-105.

<sup>49</sup> *Ibid.*, 121; Sanders, *Negro Child Welfare in North Carolina*, 9.



United States Department of the Interior  
National Park Service

## National Register of Historic Places Continuation Sheet

Section number 8 Page 21 North Carolina Industrial Home for Colored Girls  
Orange County, NC

state support until a \$2,000 1927 appropriation. Thereafter, yearly state subsidies ranged from \$1,375 to \$2,000. Although the Efland facility had only one cottage with an intended occupancy of fifteen young women, it filled a critical need in the state juvenile justice system until its March 15, 1939 closure.<sup>50</sup>

By 1926, the Division of Negro Work employed social workers in nineteen counties with sizable black populations. Fourteen of those men and women were African American. Although the division did not initially establish an Orange County office, the first appointments placed social workers in neighboring Alamance and Guilford counties. In addition, director Oxley undertook extensive community outreach, speaking at meetings of African American civic, educational, fraternal, and religious organizations including the Federation of Colored Women's Clubs. He regularly visited schools, hospitals, jails, county homes, and the state's two reformatories that served black juveniles: NCIHCG and Morrison Training School. Administrators and the public were therefore well-informed regarding NCSBCPW policies.<sup>51</sup>

The juvenile court system committed significant numbers of orphaned delinquents to rehabilitation programs in the late 1920s. In 1928, sixty-six percent of the 1,362 children placed in North Carolina's five juvenile reformatories had suffered the death of one or both parents. The following year, NCIHCG, headed by Mary E. Hill, housed twenty-two African American girls, all but one of whom were between twelve and sixteen years old. L. L. Boyd oversaw Morrison Training School's 164 black male charges. At the institutions for white youth, Eastern Carolina Training School (opened January 1926) near Rocky Mount enrolled 89 boys, State Home and Industrial School served 345 girls, and Stonewall Jackson Training School accommodated 742 young men. Mecklenburg Industrial Home in Charlotte, although not classified by the NCSBCPW as a reformatory, was a detention facility for delinquent white girls, most of whom were released on parole after brief stays.<sup>52</sup>

The state's two black orphanages benefited from facility improvements during this period. Memorial Industrial School (NR 2015) moved from a small farm south of Salem to a new 251-acre campus near Rural Hall in northwest Forsyth County in 1929. Prominent local architects Northup and O'Brien designed the complex's central administration building, three residential cottages, and a power plant, all executed in brick. Contributions from the Duke Endowment and local philanthropists including the Reynolds and Gray families subsidized the campus acquisition, construction, and operation. Residents cultivated a farm and attended a public graded school on the site. The institution provided residents

---

<sup>50</sup> Annual reports, NCIHCG, NCSBPWI, Box 163

<sup>51</sup> NCSBCPW, *North Carolina's Social Welfare Program for Negroes*, Special Bulletin Number 8 (Raleigh: 1926), 9, 22-25, 40; NCSBCPW, *Biennial Report of the NCSBCPW, 1924-1926*, 104-105.

<sup>52</sup> NCSBCPW, *Biennial Report of the NCSBCPW, 1924-1926*, 22-24, 61; NCSBCPW, *Biennial Report of the NCSBCPW, 1928-1930*, 70-71.

United States Department of the Interior  
National Park Service

## National Register of Historic Places Continuation Sheet

Section number 8 Page 22 North Carolina Industrial Home for Colored Girls  
Orange County, NC

with academic instruction through the seventh grade as well as agricultural and domestic skills training.<sup>53</sup>

The Colored Orphanage of North Carolina in Oxford reincorporated in 1927 and remained the state's most sizable entity that served North Carolina's African American youth. The Duke Endowment facilitated land acquisition and the construction of the two-story, brick, 1925 orphanage school, which was named in memory of Benjamin Newton and Sarah Pearson Angier Duke's son, Angier Buchanan Duke, as well as a one-story 1934 administrative office. In 1935, the institution served 216 children, some of whom assisted with the cultivation of approximately 91 acres of the 450-acre campus. Student enrollment numbered 333, as the school accommodated African American youth residing in Oxford and the vicinity through eighth grade, after which they attended Oxford's Mary Potter High School.<sup>54</sup>

The Rockefeller grant that had subsidized North Carolina's Division of Negro Work for six years expired in June 1931. The state then assumed responsibility for funding African American welfare initiatives in thirty-five counties. NCFWCW president and NCIHCG board chair Minnie G. Pearson was one of nine African American leaders who served on NCSBCPW's Negro Advisory Committee. Oxford, North Carolina native William R. Johnson replaced Lawrence Oxley as head of the Division of Negro Work in 1934. The division's ongoing initiatives included placing students from Bishop Tuttle Training School for Social Work at St. Augustine's College in Raleigh as interns in public and private social welfare organizations.<sup>55</sup>

The need for publicly and privately subsidized social welfare programs and institutions increased during the Great Depression. However, some, like NCIHCG, faced significant financial and administrative challenges. NCIHCG's difficulties resulted in the reformatory's March 1939 closure. This left North Carolina's juvenile court system without rehabilitation facility placement as an option for young African American women. Some were committed to jails and others placed in institutions monitored by the NCSBCPW such as "boarding homes," which provided foster care.<sup>56</sup>

---

<sup>53</sup> The institution originated as the Orphan Children's Home Company, a church-funded entity; incorporated in 1914 as the Colored Baptist Orphanage of Winston-Salem; and reorganized in November 1923 as a nondenominational organization. Heather Fearnbach, "Memorial Industrial School," National Register of Historic Places nomination, 2015.

<sup>54</sup> A March 20, 1948, fire destroyed the boys' dormitory, which was replaced the next year. NCSBCPW, *North Carolina's Social Welfare Program for Negroes*, Special Bulletin Number 8 (Raleigh: 1926), 35; North Carolina Mutual Life Insurance Company, "A 'Charitable Object' Becomes a Monument to the Development of Negro Youth," *The Whetstone*, fourth quarter 1964; Brown and Esperon, "Central Orphanage."

<sup>55</sup> NCSBCPW, *Biennial Report of the NCSBCPW, 1928-1930*, 12-13; NCSBCPW, *Biennial Report of the NCSBCPW, 1932-1934*, 86, 88, 90.

<sup>56</sup> NCSBCPW, *Biennial Report of the NCSBCPW, 1938-1940* (Raleigh: Edwards and Broughton, 1940), 34-35.

United States Department of the Interior  
National Park Service

## National Register of Historic Places Continuation Sheet

Section number 8 Page 23 North Carolina Industrial Home for Colored Girls  
Orange County, NC

Although NCFWC satisfied its indebtedness related to the Efland reformatory in 1943, the organization's advocacy for an institution to serve African American girls did not cease. NCFWC president Lula Kelsey led the charge to build a new facility that culminated in a \$25,000 state legislative appropriation ratified in March 1943. The reformatory opened in September 1944 under the direction of superintendent Mae D. Holmes in what had been the African American National Youth Administration center on Albemarle Avenue in Rocky Mount. In July 1947, the correctional institute relocated to the former Industrial Farm Colony for Women, a correctional center for white women established in 1929 near Kinston. The site became North Carolina State Industrial School for Negro Girls, also known as Dobbs School. The campus initially comprised two two-story, brick, Colonial Revival-style dormitories erected in 1929 and 1930; a dining room; a kitchen; and several utility buildings.<sup>57</sup>

By 1959, when eighty-nine young women were in residence, an administration/educational building, a kitchen/cafeteria, and an additional residential cottage had been constructed. The former kitchen housed the laundry and sewing room. NCFNWC donated almost \$12,000 in proceeds from NCIHCG's sale to Dobbs School to facilitate a chapel's construction. Fundraising continued for the chapel, which had a projected cost of \$200,000, into the 1970s.<sup>58</sup> The campus currently functions as Dobbs Youth Development Center, operated by the North Carolina Department of Public Safety. The institution provides up to forty-three residents with vocational training in automobile repair, horticulture, and culinary arts.<sup>59</sup>

---

<sup>57</sup> "Meeting an Acute Need," *Winston-Salem Journal*, March 30, 1942; "Women's Clubs Addressed by John R. Larkins," *Pittsburgh Courier*, May 15, 1943, p. 11; "Named as Supt. Of Delinquent Home," *The Carolinian*, July 29, 1944; "Negro Girls' School Ready for Inmates," *News and Observer*, September 29, 1944; Ruth G. Rush, "Tribute to Mrs. Lula Kelsey," *Federation Journal*, May 1, 1952, p. 5; M. Ruth Little, *Coastal Plain and Fancy* (Winston-Salem: Jostens Printing and Publishing, 1998), 342-343.

<sup>58</sup> "Address Delivered by Samuel E. Leonard," *Federation Journal*, January 1954, pp. 1 and 9; "Dobbs Farm," *Statesville Record and Landmark*, September 14, 1954, p. 4; Mae D. Holmes, "Training School," *Federation Journal*, Fall 1959, p. 9; "Seek \$200,000 Chapel Fund For Dobbs," *Pittsburgh Courier*, November 1, 1969, p. 5.

<sup>59</sup> North Carolina Department of Public Safety, "Youth Development Centers," <https://www2.ncdps.gov> (accessed July 2017).

United States Department of the Interior  
National Park Service

## National Register of Historic Places Continuation Sheet

Section number 9 Page 24 North Carolina Industrial Home for Colored Girls  
Orange County, NC

### Section 9. Bibliography

Andrews, R. McCants. *John Merrick: A Biographical Sketch*. Durham: Seeman Printery, 1920.

*Asheville Citizen-Times*, N. C.

Brown, Marvin A., and Patricia Esperon. "Central Orphanage." National Register of Historic Places nomination, 1987.

*Carolina Times*, Durham, N. C.

*The Carolinian*, Raleigh, N. C.

Central Children's Home of North Carolina, Inc. "About Us: History,"  
<http://www.cch-nc.org/aboutus.html> (accessed January 2015).

*Charlotte Observer*, N. C.

"Colored Orphanage Office Building Is Erected on Campus." *Oxford Public Ledger*, June 15, 1934.

Cox, Clara I., ed. *The North Carolina Federation of Women's Clubs Yearbook, 1917-1918*. High Point: North Carolina Federation of Women's Clubs, 1918.

Crenson, Matthew A. *Building the Invisible Orphanage: A Prehistory of the American Welfare System*. Cambridge, M. A.; Harvard University Press, 1998.

Crow, Jeffrey J., Paul D. Escott, and Flora J. Hatley. *A History of African-Americans in North Carolina*. Raleigh: North Carolina Department of Cultural Resources, 1992.

*Daily Advance*, Burlington, N. C.

*Daily Bulletin of the Manufacturers' Record*.

Fearnbach, Heather. "Memorial Industrial School." National Register of Historic Places nomination, 2015.

*Federation Journal*. North Carolina Federation of Women's Clubs newsletter.



United States Department of the Interior  
National Park Service

## National Register of Historic Places Continuation Sheet

Section number 9 Page 25 North Carolina Industrial Home for Colored Girls  
Orange County, NC

Fink, Arthur E. "Changing Philosophies and Practices in North Carolina Orphanages." *North Carolina Historical Review*, Volume 48, Number 4, October 1971, 333-358.

"First Annual Report of the Board of Public Charities." Document No. 26. *Executive and Legislative Documents Laid Before the General Assembly of North Carolina, Session 1869-1870*. Raleigh: John W. Holden, printer, 1870.

"History of the Colored Orphanage of North Carolina." 1935 document from Central Children's Home of North Carolina, Inc., files.

Little, M. Ruth. *Coastal Plain and Fancy*. Winston-Salem: Jostens Printing and Publishing, 1998.

"Mary McLeod Bethune, 1875-1955,"  
[http://www.nps.gov/mamc/learn/historyculture/people\\_marymcleodbethune.htm](http://www.nps.gov/mamc/learn/historyculture/people_marymcleodbethune.htm) (accessed February 2017).

Myers, John E. B. *Child Protection in America: Past, Present, and Future*. New York: Oxford University Press, 2006.

National Association of Colored Women's Clubs. "Who Are We,"  
<http://www.nacwc.org/aboutus/index.html> (accessed January 2017).

National Council of Negro Women, Inc., "Mary McLeod Bethune," <http://ncnw.org/about/bethune.htm>  
(accessed February 2017).

*New York Age*.

*News and Observer*, Raleigh, N. C.

North Carolina Department of Agriculture, Statistics Division, Farm Census Reports, 1925, Box 24  
(Onslow-Pasquotank Counties), North Carolina State Archives, Raleigh.

North Carolina Department of the Secretary of State. "Colored Orphan Asylum of North Carolina."  
<http://www.secretary.state.nc.us/Search/profcorp/4905941> (accessed January 2015).

North Carolina Department of Public Safety. "Youth Development Centers," <https://www2.ncdps.gov>  
(accessed July 2017).

United States Department of the Interior  
National Park Service

## National Register of Historic Places Continuation Sheet

Section number 9 Page 26 North Carolina Industrial Home for Colored Girls  
Orange County, NC

North Carolina Railroad Company. "NCRH History." <http://www.ncrr.com/about-ncrr/ncrr-history/>  
(accessed March 2017).

North Carolina State Board of Charities and Public Welfare. *Brief History of the Care of the Under-Privileged Child in North Carolina*, Special Bulletin Number 13. Raleigh, 1934.

\_\_\_\_\_. *Biennial Report of the North Carolina State Board of Charities and Public Welfare, 1920-1922*. Raleigh: North Carolina State Board of Charities and Public Welfare, 1922. State agency name abbreviated NCSBCPW after first appearance in text.

\_\_\_\_\_. *Biennial Report of the North Carolina State Board of Charities and Public Welfare, 1924-26*. Raleigh: NCSBCPW, 1926.

\_\_\_\_\_. *Biennial Report of the North Carolina State Board of Charities and Public Welfare, 1932-1934*. Charlotte: Observer Printing House, 1934.

\_\_\_\_\_. *Biennial Report of the North Carolina State Board of Charities and Public Welfare, 1938-1940*. Raleigh: Edwards and Broughton, 1940.

\_\_\_\_\_. *North Carolina's Social Welfare Program for Negroes*. Special Bulletin Number 8. Raleigh, 1926.

North Carolina State Board of Public Welfare Institutions and State Charitable, Penal, and Correctional Institutions (abbreviated NCSBPWI). Box 163, North Carolina State Archives, Raleigh.

Orange County Register of Deeds. Deed and Plat Books. Hillsborough, N. C.

*Pittsburgh Courier*.

Powell, William S. *Dictionary of North Carolina Biography, Volume 4*. Chapel Hill: University of North Carolina Press, 1991.

\_\_\_\_\_. *North Carolina through Four Centuries*. Chapel Hill: University of North Carolina Press, 1989.

Reeves, Margaret. *Training Schools for Delinquent Girls*. New York: Russell Sage Foundation, 1929.

Sanders, Wiley Britton. *Negro Child Welfare in North Carolina: A Rosenwald Study*. Chapel Hill: University of North Carolina Press, 1933.

United States Department of the Interior  
National Park Service

## National Register of Historic Places Continuation Sheet

Section number 9 Page 27 North Carolina Industrial Home for Colored Girls  
Orange County, NC

Scott, Anne Firor. "Most Invisible of All: Black Women's Voluntary Associations." *The Journal of South History*, Vol. 56, No. 1 (February 1990), pp. 3-22.

University of North Carolina Extension Division. *Public Welfare and the Community*, Vol. IV, No. 10 (Chapel Hill: University of North Carolina Press, 1925), 10-11, 16-17.

U. S. Censuses. Population Schedules, 1900-1940.

U. S. Department of Agriculture. Aerial photographs AJV-9-43 (1938), 6P-32 (1955), 176-78 (1975). North Carolina Office of Archives and History; Raleigh, North Carolina. Accessed through University of North Carolina-Chapel Hill's GIS Services at <http://library.unc.edu/services/data/gis-usda/orange> (February 2017).

Virginia Industrial Home for Colored Girls. *Fifth Annual Report of the Industrial Home for Colored Girls*, 1920.

Wells, John, and Susan Pickens. "Thornwell/Presbyterian College Historic District." National Register of Historic Places Nomination, 1981.

*Winston-Salem Journal*, N. C.

United States Department of the Interior  
National Park Service

# National Register of Historic Places Continuation Sheet

Section number 10 Page 28 North Carolina Industrial Home for Colored Girls  
Orange County, NC

## Section 10. Geographical Data

### Latitude/Longitude Coordinates

Latitude: 36.079577 Longitude: -79.197533

### Verbal Boundary Description

The nominated property consists of Orange County tax parcel #9844175959, as indicated by the heavy solid line on the enclosed map. Scale: one inch equals approximately one hundred feet.

### Boundary Justification

Although the original 143-acre tract has been subdivided and some commercial and residential development undertaken, the residual 2.4 acres associated with the cottage is sufficient to convey its rural character.

### Additional Documentation: Current Photographs

All photographs by Heather Fearnbach, Fearnbach History Services, Inc., 3334 Nottingham Road, Winston-Salem, N. C., on January 26, 2017, and August , 2017. Digital images located at the North Carolina SHPO.

1. North elevation
2. West elevation
3. Southwest oblique
4. Southeast oblique
5. Pavilion and pump house
6. Living room/classroom, looking northeast
7. Southwest dormitory, looking west
8. Dining room, looking west
9. Kitchen, looking southeast



United States Department of the Interior  
National Park Service

## National Register of Historic Places Continuation Sheet

Section number 10 Page 29 North Carolina Industrial Home for Colored Girls  
Orange County, NC

### Additional Documentation: Historic Images

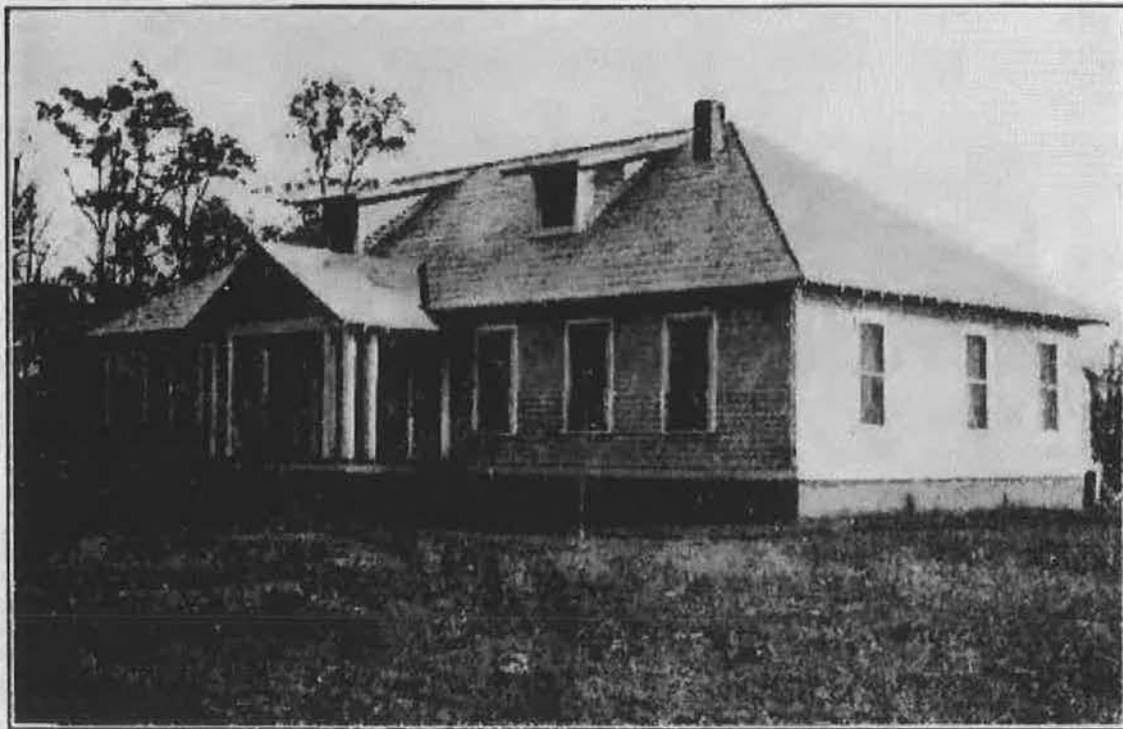

FIRST COTTAGE  
N. C. Industrial Home for Colored Girls  
Efland, N. C.  
A training school for delinquent Negro girls.

This image appeared in two North Carolina State Board of Charities and Public Welfare publications:  
*Biennial Report of the North Carolina State Board of Charities and Public Welfare, 1924-26* (Raleigh:  
NCSBCPW, 1926), p. 120, and *North Carolina's Social Welfare Program for Negroes*, Special  
Bulletin Number 8, Raleigh, 1926, p. 37.

United States Department of the Interior  
National Park Service

# National Register of Historic Places Continuation Sheet

Section number 10 Page 30 North Carolina Industrial Home for Colored Girls  
Orange County, NC

SAVE OUR GIRLS

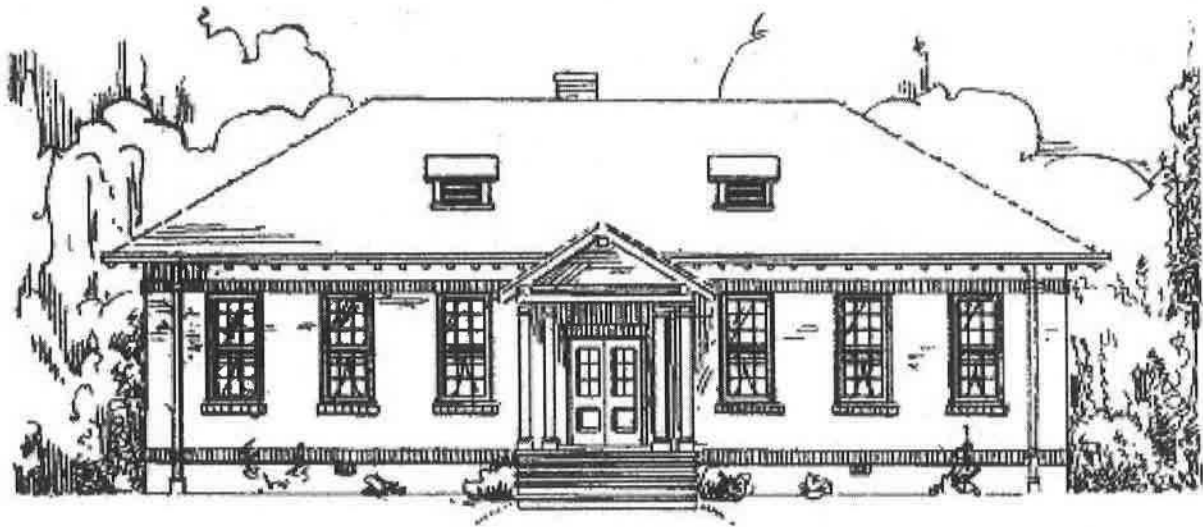

OUR FIRST COTTAGE

North Carolina Industrial Home for Colored Girls, Efland, Orange County, N. C.

NCIHCG, circa 1930 fundraising brochure, NCSBPWI, Box 163



**North Carolina Industrial Home for Colored Girls  
201 Redman Crossing, Efland, Orange County, North Carolina, National Register Boundary Map**



Redman Crossing

Railroad

Solar Farm 2016

**Pump House**, third quarter of the twentieth century, noncontributing structure

**Cottage, 1925**  
Latitude: 36.079577  
Longitude: -79.197533

National Register Boundary

Heather Fearnbach, Fearnbach History Services, Inc. / February 2017  
Base 2017 aerial photo courtesy of Google Maps at <https://www.google.com/maps>

Scale 1" = 100 feet



**North Carolina Industrial Home  
for Colored Girls,  
201 Redman Crossing,  
Efland, Orange County  
North Carolina  
First Floor Plan**

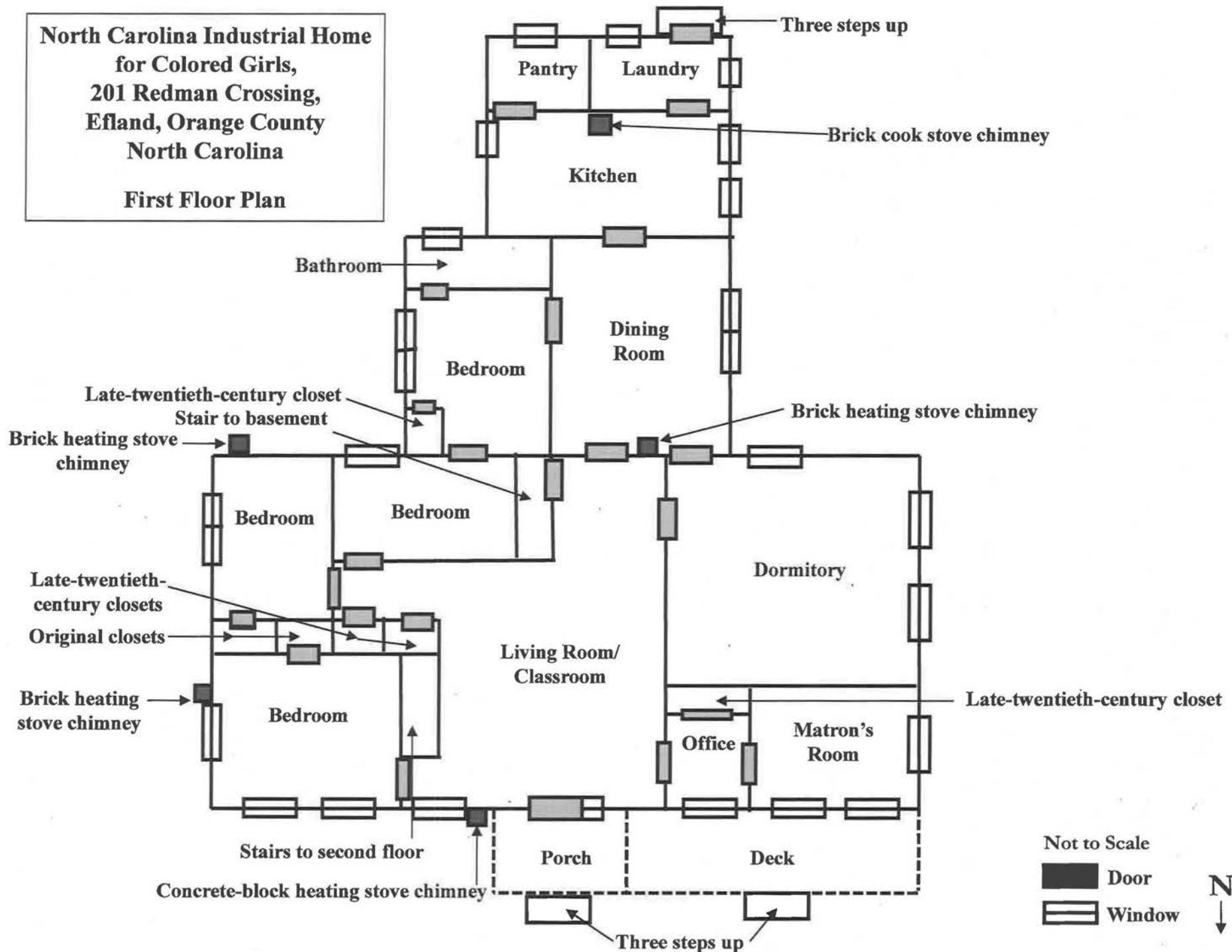

Not to Scale  
 ■ Door  
 ▭ Window  
 N  
 ↓





D. 2017. 8. 461

NC Industrial Home for Colored Girls, Orange County, NC #1



D. 2017. 8. 462

NC Industrial Home for Colored Girls, Orange County, NC #2





D. 2017. 8. 463

NC Industrial Home for Colored Girls, Orange County, NC

#3



D. 2017. 8. 464

NC Industrial Home for Colored Girls, Orange County, NC #4





D. 2017. 8. 465

NC Industrial Home for Colored Girls, Orange County, NC #5



D. 2017. 8. 466

NC Industrial Home for Colored Girls, Orange County,  
NC, #6





D. 2017. 8. 467

NC Industrial Home for Colored Girls, Orange County, NC #7



D. 2017. 8. 468

NC Industrial Home for Colored Girls, Orange County, NC #8





D. 2017. 8. 469

NC Industrial Home for Colored G.M.s, #9  
Orange County, NC



D.2017.8.470

NC Industrial Home for Colored Girls, Orange County,  
NC

#10

UNITED STATES DEPARTMENT OF THE INTERIOR  
NATIONAL PARK SERVICE

NATIONAL REGISTER OF HISTORIC PLACES  
EVALUATION/RETURN SHEET

Requested Action:

Property Name:

Multiple Name:

State & County:

Date Received: 12/11/2017      Date of Pending List:      Date of 16th Day:      Date of 45th Day: 1/25/2018      Date of Weekly List:

Reference number:

Nominator:

Reason For Review:

Accept       Return       Reject      1/25/2018 Date

Abstract/Summary Comments:

Recommendation/ Criteria:

Reviewer Jim Gabbert      Discipline Historian

Telephone (202)354-2275      Date \_\_\_\_\_

DOCUMENTATION:    see attached comments : No    see attached SLR : No

If a nomination is returned to the nomination authority, the nomination is no longer under consideration by the National Park Service.



DEC 11 2017

**North Carolina Department of Natural and Cultural Resources  
State Historic Preservation Office**

Ramona M. Bartos, Administrator

Governor Roy Cooper  
Secretary Susi H. Hamilton

Office of Archives and History  
Deputy Secretary Kevin Cherry

December 1, 2017

Stephanie Toothman, Keeper  
National Register of Historic Places  
National Park Service  
U.S. Department of the Interior  
1849 C Street NW, Mail Stop 7228  
Washington, D.C. 20240

Re: Magnolia Place (Boundary Decrease) – Burke County  
Caswell County Training School – Caswell County  
Windover – Haywood County  
West Martin School – Martin County  
North Carolina Industrial Home for Colored Girls – Orange County  
East Spencer Graded School – Rowan County

Dear Ms. Toothman:

Enclosed are the nominations for the above-referenced properties to be listed in the National Register of Historic Places.

We trust you will find the nominations to be in order. If you have any questions please call Jennifer Brosz, 919.807.6587.

Sincerely,

A handwritten signature in cursive script that reads "Kevin Cherry".

Dr. Kevin Cherry  
State Historic Preservation Officer

KC/bw: enclosures