

111

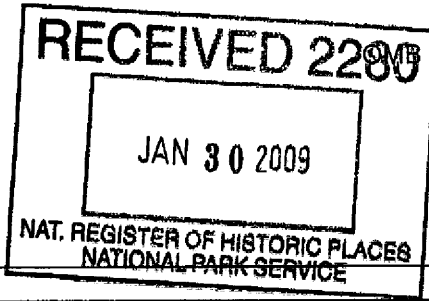

**NATIONAL REGISTER OF HISTORIC PLACES
REGISTRATION FORM**

1. Name of Property

historic name: Hays House
other names/site number:

2. Location

street & number: 18800 Hwy 61 South not for publication ___
city or town: Lorman vicinity ___
state: Mississippi code: MS county: Jefferson code: 63 zip code: 39096

3. State/Federal Agency Certification

As the designated authority under the National Historic Preservation Act of 1966, as amended, I hereby certify that this X nomination ___ request for determination of eligibility meets the documentation standards for registering properties in the National Register of Historic Places and meets the procedural and professional requirements set forth in 36 CFR Part 60. In my opinion, the property X meets ___ does not meet the National Register Criteria. I recommend that this property be considered significant ___ nationally ___ statewide X locally. (___ See continuation sheet for additional comments.)

[Signature] Date 01.28.2009
Signature of certifying official

State Historic Preservation Officer
State or Federal agency and bureau

In my opinion, the property ___ meets ___ does not meet the National Register criteria. (___ See continuation sheet for additional comments.)

Signature of commenting or other official Date

State or Federal agency and bureau

4. National Park Service Certification

I, hereby certify that this property is:
✓ entered in the National Register,
___ See continuation sheet.
___ determined eligible for the
National Register
___ See continuation sheet.
___ determined not eligible for the
National Register
___ removed from the National Register
___ other (explain):

[Signature] Date of Action 3-10-09
Signature of the Keeper
Edson H. Beall

5. Classification

Ownership of Property:
private

Number of Resources within Property:
(Do not include previously listed resources in the count)

Category of Property:
building

Contributing	Noncontributing
3	buildings sites structures objects
3	Total

Name of related multiple property listing
(Enter "N/A" if property is not part of a multiple property listing.)

**Number of contributing resources previously listed
in the National Register**

n/a

n/a

6. Function or Use

Historic Functions:
Domestic: single-family residence

Current Functions:
Domestic: single-family residence

7. Description

Architectural Classification(s):
Greek Revival

Materials:
foundation: brick, stucco
roof: fiberglass
walls: clapboard
other

Narrative Description:

See Continuation Sheets

8. Statement of Significance

Applicable National Register Criteria

- A** Property is associated with events that have made a significant contribution to the broad patterns of our history.
- B** Property is associated with the lives of persons significant in our past.
- C** Property embodies the distinctive characteristics of a type, period, or method of construction or represents the work of a master, or possesses high artistic values, or represents a significant and distinguishable entity whose components lack individual distinction.
- D** Property has yielded, or is likely to yield information important in prehistory or history.

Areas of Significance

Architecture

Period of Significance

1858

Significant Dates**Criteria Considerations:**

Property is:

- A** owned by a religious institution or used for religious purposes.
- B** removed from its original location.
- C** a birthplace or a grave.
- D** a cemetery.
- E** a reconstructed building, object, or structure.
- F** a commemorative property.
- G** less than 50 years of age or achieved significance within the past 50 years.

Significant Person(s)

n/a

Cultural Affiliation(s)

n/a

Architect/Builder

n/a

Narrative Statement of Significance: See continuation sheets.

9. Major Bibliographical References

Bibliography See continuation sheet.**Previous documentation on file (NPS)**

- preliminary determination of individual listing (36 CFR 67) has been requested.
- previously listed in the National Register
- previously determined eligible by the National Register
- designated a National Historic Landmark
- recorded by Historic American Buildings Survey

- recorded by Historic American Engineering Record

Primary Location of Additional Data

- State Historic Preservation Office
- Other State agency
- Federal agency
- Local government
- University
- Other
- Name of repository:

10. Geographical Data

Acreage of Property: less than one acre

UTM References:	Zone	Easting	Northing	Zone	Easting	Northing
A	15	679600	3521600	C		
B				D		

___ See continuation sheet.

Verbal Boundary Description See continuation sheet.

Boundary Justification: See continuation sheet.

11. Form Prepared By

name/title: Nancy H. Bell, executive director	
organization: Vicksburg Foundation for Historic Preservation	date: 6/10/2008
street & number: 1107 Washington Street	telephone: 601.636.5010
city or town: Vicksburg	state: MS
	zip code: 39183

Additional Documentation

Submit the following items with the completed form:

Continuation Sheets

Maps

A USGS map (7.5 or 15 minute series) indicating the property's location.

A sketch map for historic districts and properties having large acreage or numerous resources.

Photographs

Representative black and white photographs of the property.

Additional items (Check with the SHPO or FPO for any additional items)

Property Owner(s)

name: Glyn and Tawanda Smith	
street & number: 1559 Palmetto Trail NW	telephone: 601.754.3328
city or town: Brookhaven	state: MS
	zip code: 39601

Paperwork Reduction Act Statement: This information is being collected for applications to the National Register of Historic Places to nominate properties for listing or determine eligibility for listing, to list properties, and to amend existing listings. Response to this request is required to obtain a benefit in accordance with the National Historic Preservation Act, as amended (16 U.S.C. 470 et seq.).

Estimated Burden Statement: Public reporting burden for this form is estimated to average 18.1 hours per response including the time for reviewing instructions, gathering and maintaining data, and completing and reviewing the form. Direct comments regarding this burden estimate or any aspect of this form to the Chief, Administrative Services Division, National Park Service, P.O. Box 37127, Washington, DC 20013-7127; and the Office of Management and Budget, Paperwork Reductions Projects (1024-0018), Washington, DC 20503.

**United States Department of the Interior
National Park Service**

**NATIONAL REGISTER OF HISTORIC PLACES
CONTINUATION SHEET**

Section: 7

Page: 1

Hays House
Lorman, Jefferson County, Mississippi

The Hays House is a one-and-one-half story Greek Revival residence built in 1858 in Lorman, Jefferson County, Mississippi. The house faces south and sits on 78 acres of relatively flat wooded land. The building is a five-bay square frame residence resting on a tall brick foundation which has been stuccoed. The house is topped with a fiberglass shingle side-gable roof. The roof is pierced in the center front by a large gabled dormer with two 6/6 double-hung wood windows. There are two brick end chimneys with corbelled caps on either end of the residence. The full façade porch is covered with a flat roof supported with square wood boxed columns with molded caps and bases. There is no balustrade. The cornice of the porch is denticulated.

The main entrance is a center four-panel wood door highlighted with a three-light transom and sidelights filled with four lights and one wood panel. There are two 6/6 double-hung wood windows with louvered shutters on either side of the entry. On the rear elevation, a full-width porch recessed under the main roof has been enclosed with clapboard and now houses the kitchen and utility room. There is a shed carport attached to the rear elevation. The roof on the rear elevation is pierced in the center by a large gabled dormer with two 6/6 double-hung wood windows. Both east and west elevations have four original bays: a 6/6 double-hung wood window on either side of each chimney. In addition, a 6/6 double-hung wood window is located in the enclosed porch on each side. There are two 9/9 double-hung wood windows in the gable ends.

The design of the interior is unusual. While most houses of this style have a central hall with rooms off of the hall on right and the left, the hall in the Hays House does not begin until the rear wall of the room. The southwest room extends to the wall of the southeast room. The stair to the upper floor is located on the right wall of the hall and features a delicately turned spindle balustrade with a molded handrail. At the end of the entrance hall is the original rear door: four-panel wood door with three-light, one-panel sidelights and a peaked window head.

The mantel in the southwest room is Italian-inspired, while the other mantles are Greek. The house retains its plain baseboards and heart pine floors. The windows are enhanced with peaked cornice heads, while the bottom section of the frame is curved on the ends. The upstairs consists of a room on either side off of the center hall. There is a bathroom in the dormer on the front of the house.

There are two outbuildings remaining on the property: a shed directly behind the house and a barn east of the house. The shed is a small one-story rectangular building which has smooth-stuccoed brick on the lower half which supports a wood frame clad with vertical rough-sawn

**United States Department of the Interior
National Park Service**

**NATIONAL REGISTER OF HISTORIC PLACES
CONTINUATION SHEET**

Section: 7

Page: 2

Hays House
Lorman, Jefferson County, Mississippi

wood siding. The building is capped with a widely-overhanging standing seam metal gable roof. A wood plank single-leaf door provides access to the shed.

To the right rear of the house is a frame barn with a standing seam metal hip roof. The rectangular building is covered with weatherboard spaced to allow air and light into the barn. On the right side is a five-sided projection capped with a hip roof with a six-sided hipped pigeonaire. There are three rectangular openings which are not filled with sash. The entrance to the barn is through a large cased opening which is protected by a metal-covered shed awning supported with plain brackets.

The Hays House and its outbuildings retain a high degree of integrity in materials, design, and setting.

**United States Department of the Interior
National Park Service**

**NATIONAL REGISTER OF HISTORIC PLACES
CONTINUATION SHEET**

Section: 8

Page: 3

Hays House
Lorman, Jefferson County, Mississippi

The Hays House in Lorman, Mississippi is eligible for listing in the National Register of Historic Places in the area of architecture (Criterion C) within the context of Lorman and Jefferson County because it is a well-preserved, intact, and rare example of a Greek Revival cottage with full-façade gallery. The Mississippi Department of Archives and History's list of notable Greek Revival galleried one-story houses in Mississippi, as identified by May 2008, lists only two other one-story Greek Revival with full-façade gallery houses in the Lorman area. Of these, only China Grove remains in the area. The other house, Holly Grove, was moved to Bolton, Mississippi.

The Greek Revival style was the predominant style employed in residential architecture in Mississippi from the early 1800s to 1865. The style developed from an increased interest in the architecture of ancient Greece that was being uncovered through archaeological investigation in the early part of the 19th century. The United States, being a newly formed country, appreciated the democratic ideals of ancient Greece and adopted its architecture as its own "national style." The style is represented by both "high style" works and vernacular Greek Revival residences, the latter often built by carpenters without overseeing architects, and are found in a variety of interpretations. The "high style" residences often exhibit classic Greek Revival composition and detailing such as full-height entry porches capped with pediments or entablatures, stuccoed or wood columns topped with classical capitals, and doorways framed with sidelights and transoms. A vernacular house form that developed in Mississippi is the galleried cottage which is further classified to include galleried cottages with gable roofs and center halls, galleried cottages with gabled roofs and center pediments, gabled with central cross-gabled upper porches, and gable-roofed cottage with galleries across both a side and gable end.

The galleried cottage is closely related to the Creole cottage of Louisiana and the Biloxi cottage, common on the Mississippi Gulf Coast. All these forms rely in some fashion on Caribbean building traditions and were adopted across Alabama, Mississippi and Louisiana. Although there is variance in some features, the common features are most closely related to adaptations for tropical and subtropical climates. The galleried cottage is generally raised off the ground to allow ventilation under the structure. The houses generally have a center hall running the depth of the house and are often double-pile. Full width galleries shield the walls from daytime sun and create outdoor living spaces. Galleries could be found on one, two, three or four sides.¹

¹ Stanley Shuler. *Mississippi Valley Architecture, Houses of the Lower Mississippi Valley*. (Exton, PA: Schiffer Publishing, Ltd., 1984), p. 7-9.

**United States Department of the Interior
National Park Service**

**NATIONAL REGISTER OF HISTORIC PLACES
CONTINUATION SHEET**

Section: 8

Page: 4

Hays House
Lorman, Jefferson County, Mississippi

When combined with the vernacular house form, such as the galleried cottage, Greek Revival details allowed owners to express the latest architectural style but at a more reasonable cost than the high-style built by wealthy planters. The Hays House represents the Greek Revival cottage with a full-façade gallery. The cottage with full-façade gallery form exhibits modest and less sophisticated Greek Revival features than the "high style" examples and typically has square wooden columns instead of the more formal and "correct" round columns. The full-façade gallery of the Hays House is supported with square wood columns and its door surround is an understated version of the often elaborate classic Greek Revival entrance with sidelights and transom.

China Grove, the only other Greek Revival house with a full-façade gallery remaining in the Lorman area, was constructed about 1805 as a two-room log house and was remodeled in about 1850. At that time, the Greek Revival gallery with wood box columns was added. China Grove differs from the Hays House in its original construction and also in that it has a three-bay façade rather than a five-bay one. The Hays House is the only five-bay, full-façade gallery Greek Revival residence in the Lorman area. The house also illustrates an unusual variant of the center hall plan common to Greek Revival cottages of this period. Rather than opening to a hall that runs the depth of the house from front door to rear door, the front door of the Hays House opens directly into the front room, and the hall does not begin until the rear wall of this room. This is believed to be an original feature of the house and not the result of a later modification.

The house was built by Dr. Archer P. and Charlotte Polixia (Farley) Hays on land given to her by her parents George Porterfield and Charlotte Mills Farley. The house was called the Hays House for many years and the community was named Hays, Mississippi. Mrs. Hays gave the Illinois Central Railroad access through her property following the death of her husband. Later, because another town shared the same name, Mrs. Hays was asked by the railroad officials to change the name of her town. She agreed and named it Lorman after her daughter.

The house has retained its integrity of design and materials, both on the interior and exterior. Two outbuildings dating to the twentieth century, a shed and a barn, remain on the property within close proximity to the house and contribute to the rural setting of the house. These outbuildings also retain their integrity.

**United States Department of the Interior
National Park Service**

**NATIONAL REGISTER OF HISTORIC PLACES
CONTINUATION SHEET**

Section: 9

Page: 5

Hays House
Lorman, Jefferson County, Mississippi

Bibliography

“History of Lorman Plantation,” researched by Ann Brown, not published.

Interview with Jimmy McKell, descendant of the original owners, June 2008.

Some Notable Works of Greek Revival Architecture in Mississippi: Residential Buildings.
Compiled by the Mississippi Department of Archives and History, as of 21 May 2008.

**United States Department of the Interior
National Park Service**

**NATIONAL REGISTER OF HISTORIC PLACES
CONTINUATION SHEET**

Section: 10

Page: 6

Hays House
Lorman, Jefferson County, Mississippi

Verbal Boundary Description

The property is located on the west side of Jefferson County parcel number 0134-48-A-001, Section 48, Township 10 North, Range 2 East. The boundary being nominated is a square parcel 225' x 225' in size: measuring approximately 10' north of the north side of the barn, 10' east of the east side of the barn, 85' from the front of the house to include the front lawn, and approximately 50' on the west side of the house to include the side yard associated with the house (see site plan).

Boundary Justification

The nominated boundaries encompass approximately 1 1/8 acres of the 78 acres around the house owned by the current owner. The boundary around the house includes the house, shed behind the house, barn and drive to the house in front. This boundary was drawn to include only the immediate setting of the house as it is being nominated for architectural significance.

**United States Department of the Interior
National Park Service**

**NATIONAL REGISTER OF HISTORIC PLACES
CONTINUATION SHEET**

Section: Photographs

Page: 7

Hays House
Lorman, Jefferson County, Mississippi

Photographs

The following information is the same for all photographs:

1. Lorman Plantation House
2. Lorman, Jefferson County, Mississippi
3. Nancy Bell
4. May 2008
5. Mississippi Department of Archives and History

Photo 1	Front elevation (south)	view to north
Photo 2	Side (east) elevation	view to west
Photo 3	Side (west) elevation	view to east
Photo 4	Rear (north) elevation	view to south
Photo 5	Front (southwest) room	view to west
Photo 6	Center hall	view to north
Photo 7	Front (southeast) room	view to east
Photo 8	Shed behind house	view to north
Photo 9	Barn	view to east
Photo 10	Second floor hall	view to north

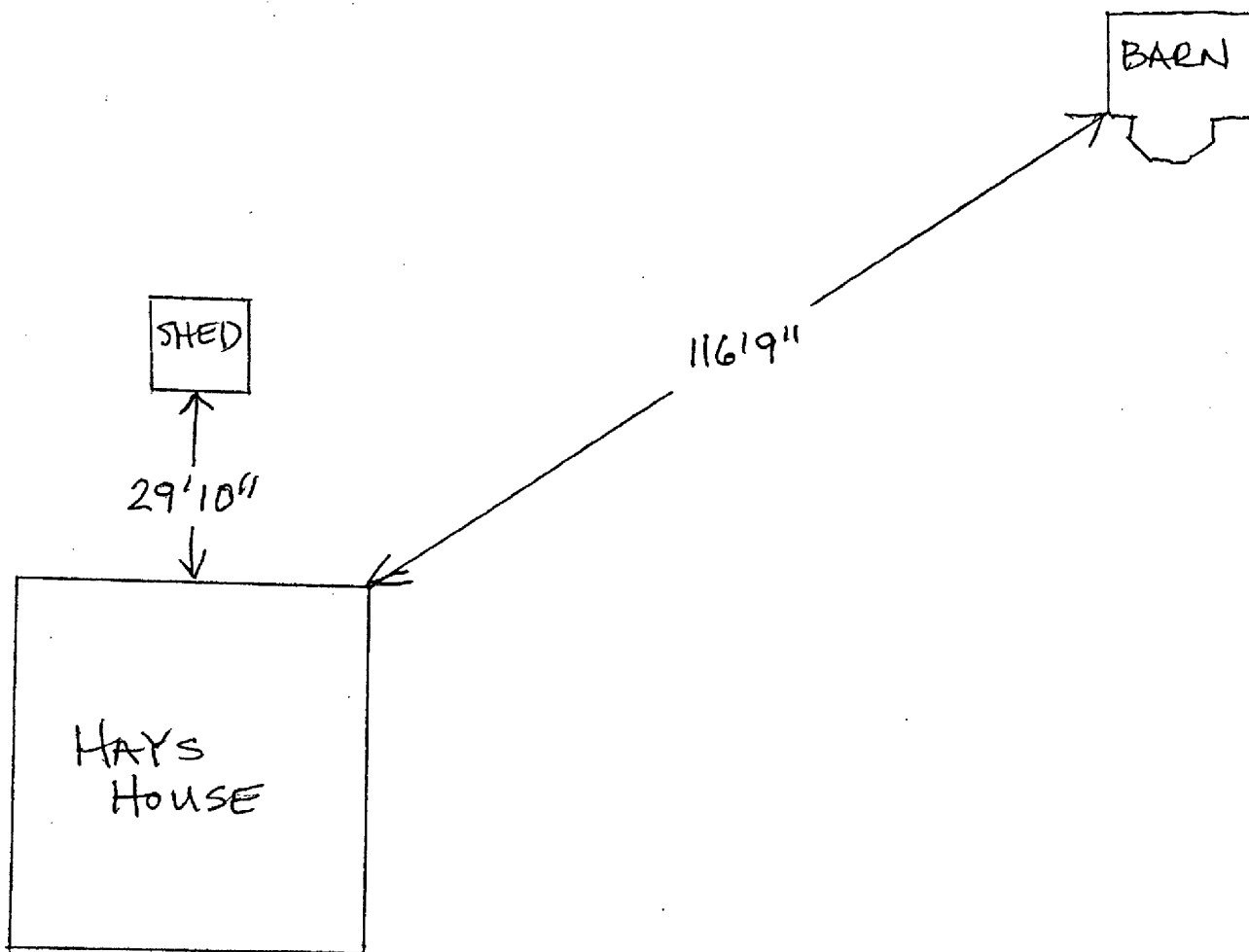

HAYS HOUSE
LORMAN, JEFFERSON COUNTY, MS

1" = 25'

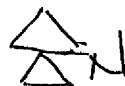

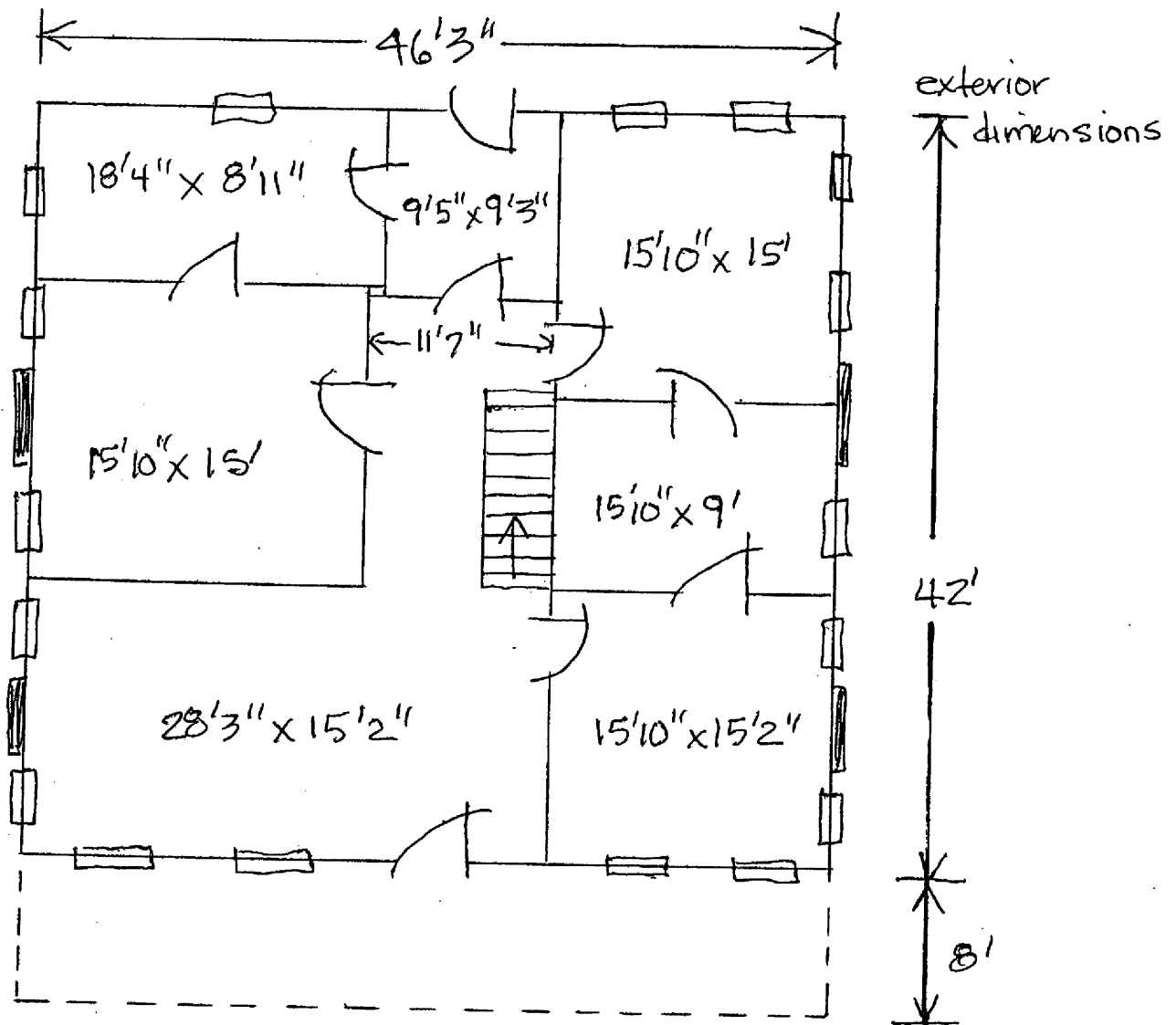

HAYS HOUSE
 LORMAN, JEFFERSON COUNTY, MS
 2008 ▲ N

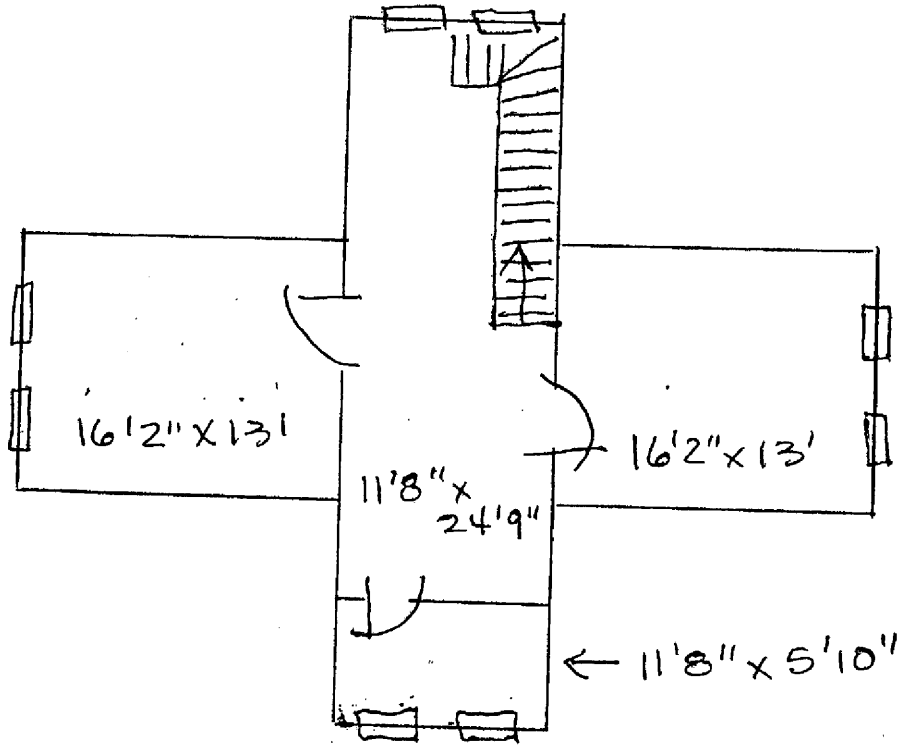

HAYS HOUSE
LORMAN, JEFFERSON COUNTY, MS

HALF-STORY
2008

