

United States Department of the Interior
National Park Service

National Register of Historic Places Registration Form

This form is for use in nominating or requesting determinations for individual properties and districts. See instructions in National Register Bulletin, *How to Complete the National Register of Historic Places Registration Form*. If any item does not apply to the property being documented, enter "N/A" for "not applicable." For functions, architectural classification, materials, and areas of significance, enter only categories and subcategories from the instructions.



1. Name of Property

Historic name: Doncaster Round Barn

Other names/site number: Bayers Barn/Round Barn

Name of related multiple property listing:

N/A

(Enter "N/A" if property is not part of a multiple property listing)

2. Location

Street & number: _____

City or town: Twin Bridges State: MT County: Madison

Not For Publication: Vicinity:

3. State/Federal Agency Certification

As the designated authority under the National Historic Preservation Act, as amended,

I hereby certify that this x nomination request for determination of eligibility meets the documentation standards for registering properties in the National Register of Historic Places and meets the procedural and professional requirements set forth in 36 CFR Part 60.

In my opinion, the property x meets does not meet the National Register Criteria. I recommend that this property be considered significant at the following level(s) of significance:

 national statewide X local

Applicable National Register Criteria:

 X A B X C D

<u>Mark F. Fannin, State Historic Preservation Officer</u>	<u>2-20-2015</u>
Signature of certifying official/Title:	Date
<u>MONTANA STATE HISTORIC PRESERVATION OFFICE</u>	
State or Federal agency/bureau or Tribal Government	

In my opinion, the property <u> </u> meets <u> </u> does not meet the National Register criteria.	
Signature of commenting official:	Date
Title :	State or Federal agency/bureau or Tribal Government

Doncaster Round Barn
Name of Property

Madison County, Montana
County and State

4. National Park Service Certification

I hereby certify that this property is:

- entered in the National Register
- determined eligible for the National Register
- determined not eligible for the National Register
- removed from the National Register
- other (explain:)

John Edson H. Beall
Signature of the Keeper

4.14.15
Date of Action

5. Classification

Ownership of Property

(Check as many boxes as apply.)

- Private:
- Public – Local
- Public – State
- Public – Federal

Category of Property

(Check only **one** box.)

- Building(s)
- District
- Site
- Structure
- Object

Doncaster Round Barn
Name of Property

Madison County, Montana
County and State

Materials: (enter categories from instructions.)

Principal exterior materials of the property: Wood, Asphalt, Concrete, Stone

Narrative Description

(Describe the historic and current physical appearance and condition of the property. Describe contributing and noncontributing resources if applicable. Begin with a **summary paragraph** that briefly describes the general characteristics of the property, such as its location, type, style, method of construction, setting, size, and significant features. Indicate whether the property has historic integrity.)

Summary Paragraph

The Doncaster Round Barn is a No Style agricultural building located on Riverside Drive about 1½ miles north of the town of Twin Bridges in Madison County. The barn sits in the broad north-south trending Jefferson River valley in southwestern Montana just north of where the Big Hole River joins the Beaverhead River to form the Jefferson River; the river is located a little over a mile west of the barn. The Tobacco Root Mountains visually dominate the valley to the east, while the Pioneer Mountains delineate the valley to the west. Agriculture remains the primary industry in the area. Although the Doncaster Round Barn once functioned as a horse barn, it no longer serves that purpose and currently sits vacant.

Built about 1882, the barn displays a circular footprint and is oriented along an east-west axis. The barn itself is comprised of three stories featuring a tiered style roof, with the conical upper level roof covering the barn's central interior, the second story multi-shed roof protecting the mid-sections of the barn, and the ground floor story multi-shed roof covering the area of the barn toward the perimeter walls. The roof is covered by asphalt shingles. The walls are clad in vertical board-and-batten siding. The primary double-door entry located in a vestibule faces east toward Riverside Drive and a secondary double-door entry, also located in a vestibule, faces west; gable roofs cover both entries. Four windows occur on the top level, eight on the second level, and 20 windows and 20 doors on the ground level of the barn. The windows remain intact. Single doors are associated with individual stalls in the interior of the barn. The second level functioned as the hay loft and is reached on the interior by a curved wood staircase. The upper story roof sports a 12-foot tall decorative base that once supported a windmill. The interior of the barn is currently (2014) undergoing renovation for use as an event center. The stalls have been dismantled, but the basic configuration will be left intact, including the famed one-quarter mile interior exercise track. Other interior features associated with the operation of the barn also remain intact, including the spiral staircase leading to the second floor hay loft and grain bin, and portions of the water delivery system.

Narrative Description

The Doncaster Round Barn is a three-story round wood frame barn. It is oriented along an east-west axis with gable roof vestibules facing east and west. The barn measures approximately 95.5 feet in diameter on the ground level, 73.8 feet in diameter on the second level, and 29.6 feet in

Doncaster Round Barn

Name of Property

Madison County, Montana

County and State

diameter on the third level. The ground and second levels are covered by multi-shed roofs sheathed in asphalt shingles. The third level has a conical roof sheathed in asphalt shingles and surmounted by a wood platform that once supported a windmill that pumped water into an interior holding reservoir. The platform is supported by brackets. The eaves have closed soffits which are terminated with wood fascias. Each roof facet is marked with a decorative modillion below the soffit. Board-and-batten siding clads the walls. Where visible, the foundation is comprised of concrete piers. Two iron smokestacks flank the east vestibule corresponding with an office south of the main entry and a dormitory north of the entry.

Windows throughout the barn sport decorative lintels and sills comprised of scroll-sawn wood. The window openings on the second and third levels contain 2/2 double-hung units, while the ground floor windows are 4-light casement units. Four windows on the third level correspond with each of the four cardinal directions. Eight windows occur on the second level and twenty windows on the ground level of the barn. All ground floor windows feature screens. Each window is separated by a doorway that corresponded with an interior horse stall. Eighteen of the doorways contain wood ledger doors while the doorways flanking the east entry contain wood paneled doors and are associated with interior office and dormitory rooms.

The primary entry vestibule faces east. Decorative diagonal stickwork frames two wood plaques. The upper plaque is decorated with a flower motif and ornamental denticulated patter. The lower plaque once held a wood carving of horses with a mountain background.¹ The double doors of the entry are of wood ledger construction with wide exterior braces. Windows in each door feature rounded tops and are 6-light fixed with decorative scrolled lintels and corniced sills.

The secondary entry vestibule faces west. Like the east vestibule, it is covered by a gable roof with the façade flush with the façade of the barn. The walls of the vestibule display wide wood fascia and board-and-batten siding. The opening is central to the vestibule and contains double vertical wood ledger doors. A four-light transom sits above the doorway; it is currently in-filled. The gable end is clad in board-and-batten siding.

Interior

The interior of the barn is mostly intact. The famed one-quarter mile dirt track inside the barn remains, but renovation work inside has removed the horse stalls (although it still possible to delineate the stalls by the interior framing). There were 18 interior horse stalls with each stall facing the central hub of the barn with doorways leading outside from each stall. The center hub contains a curved staircase leading to the hay loft/grain bins on the second floor. Ceiling joists radiate from the central point on the ground floor. Two rooms are located on the east of the interior, adjacent to the primary entry. The south room features a concrete floor, while the north room has a dirt floor. Both contain doorways leading to the exterior and both sport iron smokestacks that once provided heat. The rooms functioned as an office and a dormitory for Noah Armstrong's, the original owner, employees.

¹ The carving, entitled "Horse Fair," is currently in the possession of the owners and is on display at their Hamilton Ranch residence in Twin Bridges.

Doncaster Round Barn

Name of Property

Madison County, Montana

County and State

The curved staircase leads to the hay loft and barn granary. The circular loft features a wood floor. A wood banister on the east overlooks the interior west of the main entry. Openings in the floor remain where farmhands dropped hay to the main level. Below each of the eight windows are bins opening to the horse stalls below.

The third floor housed a water pump and 11,000 gallon water tank and equipment to distribute water to the mangers in the stalls below. There is currently no access to that level.

The framing used to construct the barn is readily observable through the structure. It appears to be a mixture of sawn and hand hewn beams.

The barn sits on a three acre tract enclosed by a wood rail fence. The A. Bayers Ditch is located about 156 feet east of the barn and parallels Riverside Drive.

Integrity

The Doncaster Barn retains good integrity of location, design, setting, materials, workmanship, feeling and association with the ranching history of the upper Jefferson River valley. The original owner, Noah Armstrong, built the barn specifically at this location in about 1882 because of the proximity of good sources of water and abundant crops of hay grown in this area. Armstrong designed the barn to take advantage of what he believed were the best horse breeding and raising practices of his time. The barn retains its original footprint, materials, and decorative detailing. It also retains its original windows, doorways, roof line, and appearance. The exterior remains as when constructed, appearing as it did when raised in the early 1880s. The setting of the property also remains intact with little or no modern development occurring in the area. The property originated as an agricultural operation and continues to function in that capacity. The materials are intact as is the workmanship that defined this structure as a singular operation not only in southwestern Montana, but in the state as a whole.

The integrity of the interior of the barn is somewhat diminished on the ground floor by the removal of the individual stalls and the siding of the circular tack room and veterinary hospital. While the walls have been removed, the wood posts the planks were attached to are still present and serve to show the arrangement and size of the stalls and interior hub area. The famed quarter-mile interior dirt exercise track is intact as are the walls of the office and dormitory. Except for the removal of the access to the third floor, there have been no changes to the second and third floors of the barn.

Doncaster Round Barn
Name of Property

Madison County, Montana
County and State

8. Statement of Significance

Applicable National Register Criteria

(Mark "x" in one or more boxes for the criteria qualifying the property for National Register listing.)

- A. Property is associated with events that have made a significant contribution to the broad patterns of our history.
- B. Property is associated with the lives of persons significant in our past.
- C. Property embodies the distinctive characteristics of a type, period, or method of construction or represents the work of a master, or possesses high artistic values, or represents a significant and distinguishable entity whose components lack individual distinction.
- D. Property has yielded, or is likely to yield, information important in prehistory or history.

Criteria Considerations

(Mark "x" in all the boxes that apply.)

- A. Owned by a religious institution or used for religious purposes
- B. Removed from its original location
- C. A birthplace or grave
- D. A cemetery
- E. A reconstructed building, object, or structure
- F. A commemorative property
- G. Less than 50 years old or achieving significance within the past 50 years

Areas of Significance

(Enter categories from instructions.)

Agriculture

Doncaster Round Barn
Name of Property

Madison County, Montana
County and State

Period of Significance

c. 1882-1965

Significant Dates

c. 1882

Significant Person

(Complete only if Criterion B is marked above.)

Cultural Affiliation

Architect/Builder

Noah Armstrong/Architect

Statement of Significance Summary Paragraph (Provide a summary paragraph that includes level of significance, applicable criteria, justification for the period of significance, and any applicable criteria considerations.)

The Doncaster Round Barn is eligible for listing in the National Register of Historic Places under criteria A and C. Constructed about 1882, the Doncaster Round Barn is eligible under Criterion A for its association with the horse ranching industry in southwestern Montana in the late nineteenth century. Ranchers brought horses into southwestern Montana specifically for breeding purposes in the 1860s following the gold strikes of 1862 and 1863. The abundant and nutritious grasses found in southwestern Montana's valleys promoted horse breeding, which culminated in the 1880s with the founding of the Doncaster Ranch north of Twin Bridges.

The Doncaster Round Barn is exceptionally significant under Criterion C as an outstanding and unique example of a round barn in Montana. Its original owner designed the barn specifically for the purpose of raising fine thoroughbred horses. The barn represents the owner's philosophies in raising horses, facilitates the care and feeding of the animals, and strove to

Doncaster Round Barn

Name of Property

Madison County, Montana

County and State

provide a pleasant environment for the animals. It retains strong integrity, representing the distinctive characteristics of the original design, method of construction, and possesses high artistic value with its unique character-defining features and materials intact. The barn was the centerpiece of the Doncaster Ranch, a historically significant ranching operation in southwestern Montana.

Narrative Statement of Significance (Provide at least **one** paragraph for each area of significance.)

The Doncaster Round Barn is eligible for the National Register under Criterion A for its association with the horse ranching industry in southwest Montana and the agricultural development of the upper Jefferson River valley. Entrepreneur Noah Armstrong established the Doncaster Ranch in 1882 after leaving the mining industry in the nearby Pioneer Mountains. Armstrong had a long-time interest in thoroughbred horses and horse racing and used the opportunity to make a profession out of something that had previously been a hobby. With his establishment of the ranch, he attempted to amass a stable of blooded thoroughbred racehorses, pasturing and training them in an area known for its abundant and nutritious grasses and good sources of water. The Doncaster Round Barn served as the centerpiece of his operation, including many innovative features designed by Armstrong to facilitate the elite of his stable of horses. This included large, well-lighted stalls that allowed the horses to at least see each other, exterior exit doors for each stall that show an extra level of care for the horses, an indoor quarter-mile exercise track, access to adjacent paddocks for each stall, a food and water delivery system on the second and third floors of the barn, and accommodations for the staff inside the barn.

Armstrong's efforts paid off in 1889, when a stallion foaled and raised at the ranch won the Kentucky Derby, beating the favorite. Montanans idolized the horse, Spokane, and, in the process, made the Doncaster Ranch a nationally recognized horse breeding and raising facility. The ranch advertised its horses for sale throughout Montana and the West in the 1890s. Armstrong sold the operation and left Montana around 1900. After the barn passed through a succession of owners, Arthur Bayers purchased the ranch in 1933 and continued Armstrong's legacy, in a way, by selling purebred Hereford cattle at sales in the barn. Purchased by the Hamilton Ranch Company in 1977, the Doncaster Round Barn has continued to be an integral part of the operation, not as a functioning barn, but as a symbol of the significance of the barn and the Doncaster Ranch to the history of the upper Jefferson River valley.

Under Criterion C, the Doncaster Round Barn is an excellent and singular example of a barn type rarely found in Montana. The barn's first owner, Noah Armstrong, designed it to be a state-of-the-art utilitarian structure to maximize the efficient care of his prize thoroughbred horses. The barn was the centerpiece of the nationally-recognized Doncaster Ranch, a successful horse breeding and raising facility that produced a Kentucky Derby winner in 1889, the same year Montana attained statehood. The barn still displays that utility of design and architectural beauty. The fenestration, footprint, and architectural detailing original to this unique design remain intact and unchanged. Materials for the barn were obtained locally and it was likely constructed by local craftsmen under the direction of Armstrong. The barn retains the distinctive

Doncaster Round Barn

Name of Property

Madison County, Montana

County and State

round footprint, the three levels, which all functioned to provide care to the animals lodged within, and the distinguishing ornamental detailing on the windows and the beautiful primary entry to the barn.

History

The lush grasses and herds of Bison drew Native Americans to the Jefferson River Valley for thousands of years. Approximately 14 miles southwest of the barn is where the Hidatsa Indians captured a young Shoshone girl named Sacajawea in about 1800. Five years later, in early August 1805, she guided the Lewis and Clark Expedition through the valley on its journey westward to the Pacific Ocean. Footsore and tired, the Corps of Discovery passed through this area on August 6th. By the 1830's trappers from the various fur companies active on the northern Great Plains and Rocky Mountains were already familiar with the Jefferson Valley.²

In July 1862, five prospectors discovered gold on Grasshopper Creek about 50 miles southwest of the future site of the Doncaster Round Barn. The gold strike precipitated the first gold rush stampede to what would become southwestern Montana. By December 1862, several hundred people lived in Bannack, the mining camp adjacent to the Grasshopper Creek diggings. In the spring of 1863, other hopeful prospectors fanned out across the region in search of new gold bonanzas, with the result that in May of that year, eight men made a rich strike on Alder Creek about 26 miles southeast of the barn site. The enormously rich placer mines drew thousands of people to the area and resulted in the formation of Virginia City, Nevada City, Adobetown, and Junction in the gulch.³

The success of the gold strike, however, also depended on a good transportation system and men willing to sell agricultural products and livestock to the miners. The confluence of the Big Hole, Beaverhead, and Ruby rivers just south of the barn site contributed to the area's strategic importance for both transportation and agriculture. In 1867, brothers Mortimer and John Lott established toll bridges across the Beaverhead and Big Hole rivers along with a small settlement called Twin Bridges. Merchants in Twin Bridges sold supplies and other services to travelers on the Virginia City branch of the Montana-Utah Road.⁴ Twin Bridges also functioned as a trade center for surrounding farms and ranches. Its importance grew when in 1897 the Northern Pacific Railway constructed its Alder branch line through the valley and Twin Bridges to the

² Stephen E. Ambrose, *Undaunted Courage: Meriwether Lewis, Thomas Jefferson, and the Opening of the American West*, (New York: Simon & Schuster, 1996), 187; Gary E. Moulton, ed., *The Definitive Journals of Lewis & Clark: Through the Rockies to the Cascades*, vol. 5 (Lincoln: University of Nebraska Press, 2002), 52-54.

³ Don Spritzer, *Roadside History of Montana*, (Missoula: Mountain Press Publishing Co, 1999), 227-229, 238-239; Michael P. Malone, Richard B. Roeder, and William L. Lang, *Montana: A History of Two Centuries*, Rev ed. (Seattle: University of Washington Press, 1992), 65, 67; Merrill G. Burlingame, *The Montana Frontier*, (Helena: State Publishing Co., 1942), 86-87.

⁴ The road between Bannack and Virginia City was also known as Road Agent Trail because of the number of robberies that took place along it in 1863.

Doncaster Round Barn

Name of Property

Madison County, Montana

County and State

mouth of Alder Gulch. The railroad cemented Twin Bridges' importance to the upper Jefferson River Valley.⁵

Noah Armstrong and the Doncaster Ranch

The January 1870 General Land Office map for Township 3 South, Range 6 West shows no settlers in the NE¼ SW¼ of Section 14. The existing Riverside Drive is shown on the map and labeled the Helena branch of the Montana-Utah Road. Jacob Wyrouk lived about one-half mile north of the future site of the barn in 1870, while a man named Himmell lived a quarter mile southwest of the future barn site.

A native of New York, John Van Brocklin arrived in Montana Territory about 1865 and settled in the Jefferson River valley. In January 1876, Van Brocklin obtained title to the 160 acres encompassing the future site of the Doncaster Round Barn. The 1870 U.S. Census lists his occupation as a farmer. By 1880, however, he lived in Glendale and worked as a carpenter. Sometime between 1876 and 1879, John Mannheim acquired the property from Van Brocklin. Mannheim died in 1879 and left the property to his widow, Veronica, who transferred title to her daughter Elizabeth and her husband Charles Armstrong in 1882. The couple sold the property for \$5,000 to Charles's father, mining entrepreneur Noah Armstrong, that same year.⁶

Born in Ontario, Canada in 1823, Noah Armstrong immigrated to the United States in 1853, settling in Minnesota. He brought with him to his adoptive country a strong background in chemistry and an interest in mining and assaying. He relocated to Montana in the 1860s. In 1873, Armstrong formed a partnership with Elias Atkins, president of the Atkins Saw Works Company of Indianapolis. The men planned to locate and develop new mines in southwestern Montana Territory. They hired prospectors to find promising gold quartz lodes and stake them in the Pioneer Mountains northwest of Virginia City in 1872. The partners staked claims on Lion Mountain in the Bryant Mining District and began development of hard rock mines there by the following year. In January 1877, Armstrong consolidated his holdings in the mining district and formed the Hecla Consolidated Mining Company and began extensive development of the mines there. In 1874, the company constructed a smelter at the new mining camp of Glendale. The company was profitable, but reorganized in 1879, removing Armstrong as the General Manager of the firm. It is unclear why Armstrong withdrew from the operation of the company he helped form, whether he retained his holdings in the company, or divorced himself from it entirely. After leaving Glendale, Armstrong "remained engaged in banking, assaying, and small scale

⁵ Spritzer, *Roadside History of Montana*, 233; Wolle, *Montana Pay Dirt*, 207-209; Donald B. Robertson, *Encyclopedia of Western Railroad History*, vol. 2 (Dallas, Texas: The Taylor Publishing Co., 1991), 332; US Census Records, viewed at www.ancestry.com.

⁶ General Land Office Records, viewed at www.glorecreds.blm.gov; United States Census Records, viewed at www.ancestry.com; Charles Armstrong Reminiscence in "Spokane, Winner of the Kentucky Derby, 1889" [hereafter referred to as Armstrong Reminiscence, viewed at www.glendatlemontana.com]; Copy of the reminiscence is also available in the Doncaster Round Barn file stored at the Montana State Historic Preservation Office, Helena, Montana.

Doncaster Round Barn

Name of Property

Madison County, Montana

County and State

mining” in Montana. It was at this time that he decided to pursue another interest of his: the breeding of thoroughbred race horses.⁷

It is unclear the origin of Armstrong’s interest in thoroughbred horse breeding. While General Manager of the Hecla Consolidated Mining Company and living in Glendale, he sponsored horse races in the mining camp. With his son and daughter-in-law’s acquisition of the Mannheim property north of Twin Bridges, it is possible Armstrong saw an opportunity to pursue as a business what had previously been only a hobby. Shortly after purchasing the property in 1882, Armstrong began buying up neighboring property until he amassed an estate of over 4,000 acres and christened it the Doncaster Farm in honor of his favorite racehorse. Of that, 2,800 acres was enclosed by fences and subdivided into fields of 50 to 150 acres. His son, Charles, later wrote that the Doncaster Farm was a site “beyond compare; one of the most favorable localities for fashionable horse breeding purposes that is to be found in the entire inter-mountain region.”⁸

The crops required little irrigation and produced prodigious amounts of timothy, red top, bluegrass, Lucerne, and “two different varieties of clover.” So much so, that Charles Armstrong later boasted that these grasses were produced in such abundance that “the statement of their yield would be received with incredulity by many who have not actually witnessed the results obtained from successively recurring hay harvests.” Noah Armstrong spent thousands of dollars purchasing good breeding stock from Kentucky horse farms and elsewhere. He also spent considerable money on the construction of buildings necessary for the operation of a successful horse breeding operation, including the famed Doncaster Round Barn.⁹

The Doncaster horse farm prospered for nearly two decades, raising and selling thoroughbred horses to buyers throughout Montana and the western United States. One horse raised on the farm and in the Doncaster barn, Spokane, went on to win the 1889 Kentucky Derby, the only racehorse from Montana to do so.¹⁰ The Panic of 1893 hit the Doncaster Farm hard and the company sharply curtailed its activities during the decade. Noah Armstrong, for reasons that aren’t entirely clear, sold the ranch to Max Lauterbach in 1900. Noah left Montana to pursue interests in Seattle, where he died in 1907.¹¹

Born in Bavaria in 1859, Max Lauterbach immigrated to the United States in 1879 and served in the U. S. Army until 1884 when he was discharged from the service. He moved to Dillon, Montana in 1884 and worked for the Oregon Short Line Railroad until 1885 when he “took up land in Madison County and went into the cattle business.” Sometime in the 1880s, he added

⁷ United States Census Records viewed at www.ancestry.com; Muriel Sibell Wolle, *Montana Pay Dirt*, (Athens, Ohio; Sage Books, 1963), 187-188, 190; Susan R. Nardinger and Mary T. Flanagan, *Montana Centennial Sites: Doncaster Ranch*, 11 September 1989, on file at the Montana Historic Preservation Office, Helena, Montana; Armstrong Reminiscence.

⁸ Wolle, *Montana Pay Dirt*, 207; Armstrong Reminiscence.

⁹ Armstrong Reminiscence, Ibid.

¹⁰ Susan R. Nardinger, *Spirit Horse of the Rockies*, (Helena: Falcon Press, 1988), 137-141, 144.

¹¹ Nardinger and Flanagan, *Montana Centennial Sites*; Perry Backus, “Twin Bridges, Montana: Home of a Derby Winner; a Piece of Montana History,” *The Montana Standard*, 22 November 2003.

Doncaster Round Barn

Name of Property

Madison County, Montana

County and State

sheep to his growing ranch on Blacktail Creek near Dillon. When he purchased the Doncaster Ranch from Noah Armstrong, he shifted his cattle operation to his new holdings and raised sheep on his ranch near Dillon. By 1902, Lauterbach owned the 4,000 acre Doncaster Ranch, along with the 3,800 acre sheep ranch and he also leased state land in both localities. In 1913, he owned a total of 8,300 acres. By 1920, Lauterbach divided his time between the two ranches and lived in Dillon. His wife, Josephine, died in 1933. Lauterbach remarried shortly afterwards, sold the Doncaster Ranch to Arthur Bayers and left the United States. The ranch remained in the Bayers family until 1997. The current owners purchased the property in 2010.¹²

Spokane

Arguably, the crowning event associated with the Doncaster Round Bar is Spokane. A chestnut stallion foaled at the Doncaster Round Barn in 1886, Spokane was the only Montana (Montana Territory at the time) horse born and trained in Montana to win the Kentucky Derby. In 1889, Noah Armstrong entered the horse in the 15th running of that classic race. Smaller than the heavily favored Proctor Knott, Spokane was not expected to win the race, but he defeated Proctor Knott, running the 1½- miles track in a record 2:34:50, a record which stands to this day thanks to a shortening of the track course in 1896 to 1 ¼ miles. Spokane's win served as an immediate source of pride not only to people living in the Montana Territory, but to people of the West; no one ever expected a horse born and raised in the hinterlands of a territory to compete, much less win horse racing's greatest spectacle. One and a half months later, in June of 1889, Spokane also won the American Derby setting another record as the first horse to win two Derbies. The same year Spokane won the Clark Handicap races. After his spectacular Kentucky Derby win, Spokane became the darling of the national and territorial media. Armstrong joked that Kentucky, Washington, Illinois and Tennessee all tried to claim Spokane in various ways during the horse's life, but he stated that it was Montana that was Spokane's birthplace and would remain his home. Armstrong put Spokane out to pasture at various Kentucky horse farms until returning him to Montana about 1900. It is thought Spokane died in Montana around 1916.¹³

Doncaster Round Barn

The Doncaster Round Barn served as the centerpiece of Noah Armstrong's operations in the Jefferson River valley north of Twin Bridges. Designed by Noah Armstrong and built in 1882, the barn featured many innovative features conducive to the breeding and maintenance of thoroughbred racehorses. About 1892, Armstrong's son, Charles, left a detailed description of the barn and how it functioned, which he called "a model of architectural beauty and convenience."

Armstrong reported that the barn rests on "stone abutments" driven twelve feet below the water table to the "hard bare" bedrock beneath. Noah Armstrong's workers quarried the stone at nearby Hell's Canyon about five miles north of the barn site. They also drilled a well at the

¹² *Progressive Men of the State of Montana*, (Chicago: A. W. Bowen & Co., 1902), 710-711; Harriet Fitzgerald Sanders, *A History of Montana*, volume 2 (Chicago: The Lewis Publishing Company, 1913), 1289; U. S. Census Records; Backus, "Twin Bridges."

¹³ Susan R. Nardinger, *Spirit Horse of the Rockies*, (Helena: Falcon Press, 1988), 137-141, 144; Montana Cowboy Hall of Fame, *Spokane, Montana's Kentucky Derby Winner*, Found at: <http://www.montanacowboyleft.com/151001/180283.html>.

Doncaster Round Barn

Name of Property

Madison County, Montana

County and State

approximate center of barn. The barn incorporates approximately 110,000 feet of lumber. The walls are comprised of three layers of wood planks with each layer insulated with “double sheets of building paper.” The office sits in the south of the primary entry to the barn on the east, with a dormitory for employees on the north side of the entry. The outer tier of the round barn was occupied by 18 box stalls, each 12 feet square and divided by walls reaching to a height of four feet. From there railings reached to the ceiling of the ground level of the barn “giving each horse a chance to see his neighbors for about halfway around the building.” Armstrong believed that “this promotion of neighborly companionship greatly [relieved] the monotony of indoor horse life.” Each stall included a doorway to the outside and a window. The doorways led to 26 2½ acre paddocks for each horse.¹⁴

The stalls opened inward onto a circular one-quarter mile track that measured 20 feet wide. The track was used to break young horses and for exercise purposes. It could also be used to shelter the outdoor horses during periods of inclement weather. The track was reached via entries on the east and west of the barn. The east entry could accommodate, according to Armstrong, a “ten-horse wagon laden with hay.”¹⁵

The inner side of the track consisted of a circular structure that contained the tack room, veterinary stalls, a hay and grain elevator, and “the spiral staircase to the upper floors and well pipe.” The second floor functioned as a hay loft and grain bin. The “large circular room” could store at least fifty tons of hay and the grain bins hold at least 12,000 bushels of corn and grain. Charles Armstrong reported that the “granary floors slope toward the side apartments. This for convenience in drawing off the supply for the stable which is conveyed by automatic conveyance to the mangers in the box stalls below.” Portions of those conveyance structures still exist below the windows on the second floor. An 11,000 gallon reservoir occupied the third floor of the barn. A well sunk through the center of the barn fed the reservoir. A windmill on a 12-foot high tower surmounting the barn pumped the water into the tank. From there, iron pipes carried water to each of the stalls below. It also functioned as a fire suppression system.¹⁶

The unique design and functionality of the barn was, according to Charles Armstrong, beyond compare. He wrote that:

So the entire building, while every foot of space seems to have its appropriate function, there is ample room for everything; the light is all that can be wished for, and the ventilation of air, good at the same time, maintaining a comfortable degree of heat no matter what the frigidity of temperature might be. In the manner of convenience it cannot be excelled, all supplies of hay, grain, water, etc. coming from above and being automatically conveyed to the stables without intermediate aid.

¹⁴ Armstrong Reminiscence.

¹⁵ Ibid.

¹⁶ Ibid.

Doncaster Round Barn

Name of Property

Madison County, Montana

County and State

He concluded that “as a whole, it is the handsomest, most unique and complete establishment of its kind in the west, if not the whole country.”¹⁷

Deer Lodge banker and horse rancher Samuel Larabie effused of the Doncaster Round Barn that “for elegance of design, convenience, in all its appointments and general adaptability to the purposes for which it was intended, that is for breeding, raising, and training of horses, there is nothing equal to it on any of the great horse farms of Kentucky.” When the Armstrongs left Montana around 1900, it is not known in what capacity the barn functioned thereafter. It is clear that the interior layout of the barn remained intact until recently.¹⁸

By the time Arthur Bayers purchased the property in 1933, the barn had fallen into disrepair. He raised cattle on the ranch and utilized the interior when selling his prized Hereford cattle. His son, Byron, remembered that the family tried to maintain the building as best they could, painting it every five years. However, Bryon said that the maintenance was expensive and they had to buy paint by the barrel to complete the task, “this went on,” he said, “for 53 years.” Bayers claimed “a lot more cattle history was made in the Round Barn than horse history, other than Spokane and the Derby.” The Bayers sold the property to real estate developer Allan Hamilton in 1997. He attempted to restore or, at least, arrest the deterioration of the barn. Hamilton had it re-roofed and the barn leveled up under his stewardship.¹⁹ The current owners, Tony and Amie James, purchased the property in 2010 and are making efforts to rehabilitate the barn for use as a community event venue.²⁰

Architectural Significance: Polygonal and round barns

Polygonal or round barns originated in Bronze Age Great Britain about 4,000 years ago. The form occasionally appeared in Western Europe over the succeeding millennia, but it wasn't until nineteenth century North America that it saw much use. George Washington designed and built a round brick threshing barn in the last decade of the eighteenth century. In 1826, Shakers in Hancock, Massachusetts built a round barn that served as a model for other structures of that type during the decade. They were, however, never built in large numbers because of the difficulty in design, because owners “required a flair for mathematics to design and build them.”²¹

Despite the mathematical issues involved in their construction, men, such as Orson Squire Fowler and Elliott W. Stewart, ballyhooed polygonal and round barns in upstate New York and the Midwest beginning in the 1850s. Promoted as cheaper to build, while enclosing the same area as a rectangular barn, polygonal and round barns were not only more aesthetically pleasing,

¹⁷ Ibid.

¹⁸ Ibid; M. A. Leeson. *A History of Montana, 1739-1885*, (Chicago: Warner, Beers & Company, 1885), 1078.

¹⁹ Evidence of that leveling can be seen on the north side of the barn. Hamilton used concrete to level the structure.

²⁰ Backus, “Twin Bridges.”

²¹ Eric Arthur and Dudley Whitney, *The Barn: A Vanishing Landmark in North America*, (Greenwich, Connecticut: New York Graphic Society, 1972), 147; Chere Justo and Christine W. Brown, *Hand Raised: The Barns of Montana*, (Helena: Montana Historical Society Press, 2011), 10.

Doncaster Round Barn

Name of Property

Madison County, Montana

County and State

but more versatile in function than rectangular barns. The journals lauded round or polygonal barns because of their economy "in volume-to-surface-area – and efficiency". They allowed farmers and ranchers to move their livestock into stanchions or stalls, feed them from a central area from the hay loft/grain bins above and to easily clean the alleyway between the hub and the stalls. Polygonal and round barns increased productivity and boosted profits for their owners. More windows allowed more lighting, and improved ventilation for the animals. By arranging stalls radially along the walls of the structure, farmers could more efficiently feed and water the animals from a central location. Balloon-frame polygonal barns, like the Doncaster Round Barn, described in the farm journals generally exhibited vertical wood walls, thus capturing the feeling of a round barn without the hassle of finding materials to adequately clad it. Noah Armstrong's barn exhibited all these principles.²²

A review of the literature concerning polygonal and round barns suggests that Noah Armstrong was well aware of the arguments in favor of the type over the standard rectangular plan barn. For Armstrong, horse breeding was more than just a hobby, it was an interest that he studied in depth and was familiar with from his time in the Midwest. He was undoubtedly familiar with farm journals promoting the design. The journals published articles describing polygonal and round barn designs for cattle, not for horses. Armstrong took the best of those guidelines and adapted them for horses. This included, windows on each facet of the barn, an open airy interior with doorways to separate paddocks outside the barn, and a central point from which the animals could be cared for. Armstrong also followed the journals' advice by storing hay on the second floor of the barn and dropping hay to the stalls below by individual chutes. The interior well, pumping system and storage tank on the third level was Armstrong's innovation. The Doncaster Round Barn displays the principles behind and the rationale for the construction of polygonal and round barns developed in the late 19th century. It also represents Noah Armstrong's ideas and innovations for adapting the design for raising and caring for thoroughbred racehorses. While polygonal and round barns were popular in the Midwest, the form never really caught on in Montana. Farmers and ranchers built only a handful of round barns in the Treasure State, with the Doncaster Round Barn being one of the best examples of the type.²³

²² Arthur and Whitney, *The Barn*, 147, 148, 149, 151, 153; Justo and Brown, *Hand Raised*, 10.

²³ Round and Polygonal Barns of Indiana, National Register of Historic Places Multiple Properties Document, Indiana Department of Natural Resources, February 1993; *Barn Plans and Outbuildings*, (New York: Orange Judd Company, 1881), 63-65.

Doncaster Round Barn
Name of Property

Madison County, Montana
County and State

9. Major Bibliographical References

Bibliography (Cite the books, articles, and other sources used in preparing this form.)

- Arthur, Eric and Dudley Witney. *The Barn: A Vanishing Landmark in North America*. Greenwich, Connecticut: New York Graphic Society, LTD, 1972.
- Backus, Perry. "Twin Bridges, Montana: Home of a Derby Winner; a Piece of Montana History." *The (Butte) Montana Standard*, 22 November 2003.
- Barn Plans and Outbuildings*. New York: Orange Judd Company, 1881.
- Burlingame, Merrill G. *The Montana Frontier*. Helena: State Publishing Co., 1942.
- Charles Armstrong Reminiscence in "Spokane, Winner of the Kentucky Derby, 1889." Viewed at www.glendatlemontana.com; Copy of the reminiscence is also available in the Doncaster Round Barn file stored at the Montana State Historic Preservation Office, Helena, Montana.
- Cheney, Roberta Carkeek. *Names on the Face of Montana: The Story of Montana's Place Names*. Missoula: Mountain Press Publishing Company, 1990.
- Historic Context Study of Minnesota Farms, 1820-1960. Four volumes. Prepared for the Minnesota Department of Transportation by Gemini Research, June 2005. Viewed at <http://www.dot.state.mn.us/culturalresources/studies/farmsteads.html>.
- Justo, Chere and Christine W. Brown. *Hand Raised: The Barns of Montana*. Helena: Montana Historical Society Press, 2011.
- Leeson, M. A. *History of Montana, 1739-1885*. Chicago: Warner, Beers & Company, 1885.
- Malone, Michael P., Richard B. Roeder, and William L. Lang. *Montana: A History of Two Centuries*. Rev ed. Seattle: University of Washington Press, 1992.
- Nardinger, Susan R. *Spirit Horse of the Rockies*. Helena: Falcon Press, 1988.
- Nardinger, Susan R. and Mary T. Flanagan. *Montana Centennial Sites: Doncaster Ranch, 11 September 1889*. On file at the Montana Historic Preservation Office, Helena, Montana.
- Progressive Men of the State of Montana*. Chicago: A. W. Bowen & Co., 1902.
- Robertson, Donald B. *Encyclopedia of Western Railroad History*. Three volumes. Dallas, Texas: The Taylor Publishing Company, 1991.
- Round and Polygonal Barns of Indiana. National Register of Historic Places Multiple Properties Document. Indiana Department of Natural Resources, 3 February 1993.
- Sanders, Harriet Fitzgerald. *A History of Montana*. Three volumes. Chicago: The Lewis Publishing Company, 1913.

Doncaster Round Barn
Name of Property

Madison County, Montana
County and State

Spokane, Montana's Kentucky Derby Winner, Montana Cowboy Hall of Fame. On line at:
<http://www.montanacowboyfame.com/151001/180283.html> . Accessed October 5,
2014.

Spritzer, Don. *Roadside History of Montana*. Missoula: Mountain Press Publishing Co.,
1999.

Wolle, Muriel Sibell. *Montana Pay Dirt*. Athens, Ohio: Sage Books, 1963.

Previous documentation on file (NPS):

- preliminary determination of individual listing (36 CFR 67) has been requested
- previously listed in the National Register
- previously determined eligible by the National Register
- designated a National Historic Landmark
- recorded by Historic American Buildings Survey # _____
- recorded by Historic American Engineering Record # _____
- recorded by Historic American Landscape Survey # _____

Primary location of additional data:

- State Historic Preservation Office
- Other State agency
- Federal agency
- Local government
- University
- Other
- Name of repository: _____

Historic Resources Survey Number (if assigned): _____

10. Geographical Data

Acreeage of Property 3.0

Use either the UTM system or latitude/longitude coordinates

Latitude/Longitude Coordinates

Datum if other than WGS84: _____

(enter coordinates to 6 decimal places)

- | | |
|------------------------|------------------------------|
| 1. Latitude: 45.570111 | Longitude: 112.3136544684289 |
| 2. Latitude: | Longitude: |
| 3. Latitude: | Longitude: |
| 4. Latitude: | Longitude: |

Or

Doncaster Round Barn
Name of Property

Madison County, Montana
County and State

UTM References

Datum (indicated on USGS map):

NAD 1927 or NAD 1983

1. Zone: 12 Easting: 397496 Northing: 5047125

Verbal Boundary Description (Describe the boundaries of the property.)

The Doncaster Round Barn boundaries consist of the barn and the acreage immediately surrounding it that is currently enclosed by a wood rail fence. The barn is located in the SW¹/₄ NE¹/₄ SW¹/₄ of Section 14, 3S, R6W. The property is delineated on the east by the Bayers Ditch and Riverside Drive.

Boundary Justification (Explain why the boundaries were selected.)

The property includes the barn and the acreage immediately surrounding the building. The acreage was at one time separated into 18 lots each corresponding to an interior stall. This allowed the horses to exercise and commune with other horses at the ranch. That acreage is still delineated in the area immediately surrounding the barn.

11. Form Prepared By

name/title: Jon Axline/Historian
organization: _____
street & number: 448 Parriman Street
city or town: Helena state: MT zip code: 59602
e-mail: jaxline@mt.gov
telephone: 406-422-2111
date: September 22, 2014

Property Owner:

(Complete this item at the request of the SHPO or FPO.)

name Hamilton Ranch
street & number P.O. Box 447 telephone _____
city or town Twin Bridges state MT zip code 59754

Doncaster Round Barn
Name of Property

Madison County, Montana
County and State

Additional Documentation

Submit the following items with the completed form:

- **Maps:** A **USGS map** or equivalent (7.5 or 15 minute series) indicating the property's location.
- **Sketch map** for historic districts and properties having large acreage or numerous resources. Key all photographs to this map.
- **Additional items:** (Check with the SHPO, TPO, or FPO for any additional items.)

Photographs

Submit clear and descriptive photographs. The size of each image must be 1600x1200 pixels (minimum), 3000x2000 preferred, at 300 ppi (pixels per inch) or larger. Each photograph must be numbered and that number must correspond to the photograph number on the photo log. For simplicity, the name of the photographer, photo date, etc. may be listed once on the photograph log and doesn't need to be labeled on every photograph.

Photo Log

Name of Property:

City or Vicinity:

County:

State:

Photographer:

Date Photographed:

Description of Photograph(s) and number, include description of view indicating direction of camera:

1 of ____.

Please See Continuation Sheets

Paperwork Reduction Act Statement: This information is being collected for applications to the National Register of Historic Places to nominate properties for listing or determine eligibility for listing, to list properties, and to amend existing listings. Response to this request is required to obtain a benefit in accordance with the National Historic Preservation Act, as amended (16 U.S.C.460 et seq.).

Estimated Burden Statement: Public reporting burden for this form is estimated to average 100 hours per response including time for reviewing instructions, gathering and maintaining data, and completing and reviewing the form. Direct comments regarding this burden estimate or any aspect of this form to the Office of Planning and Performance Management, U.S. Dept. of the Interior, 1849 C. Street, NW, Washington, DC.

United States Department of the Interior
National Park Service

Doncaster Round Barn
Name of Property
Madison County, Montana
County and State
Name of multiple listing (if applicable)

National Register of Historic Places Continuation Sheet

Section number Maps and floorplans

Page 21

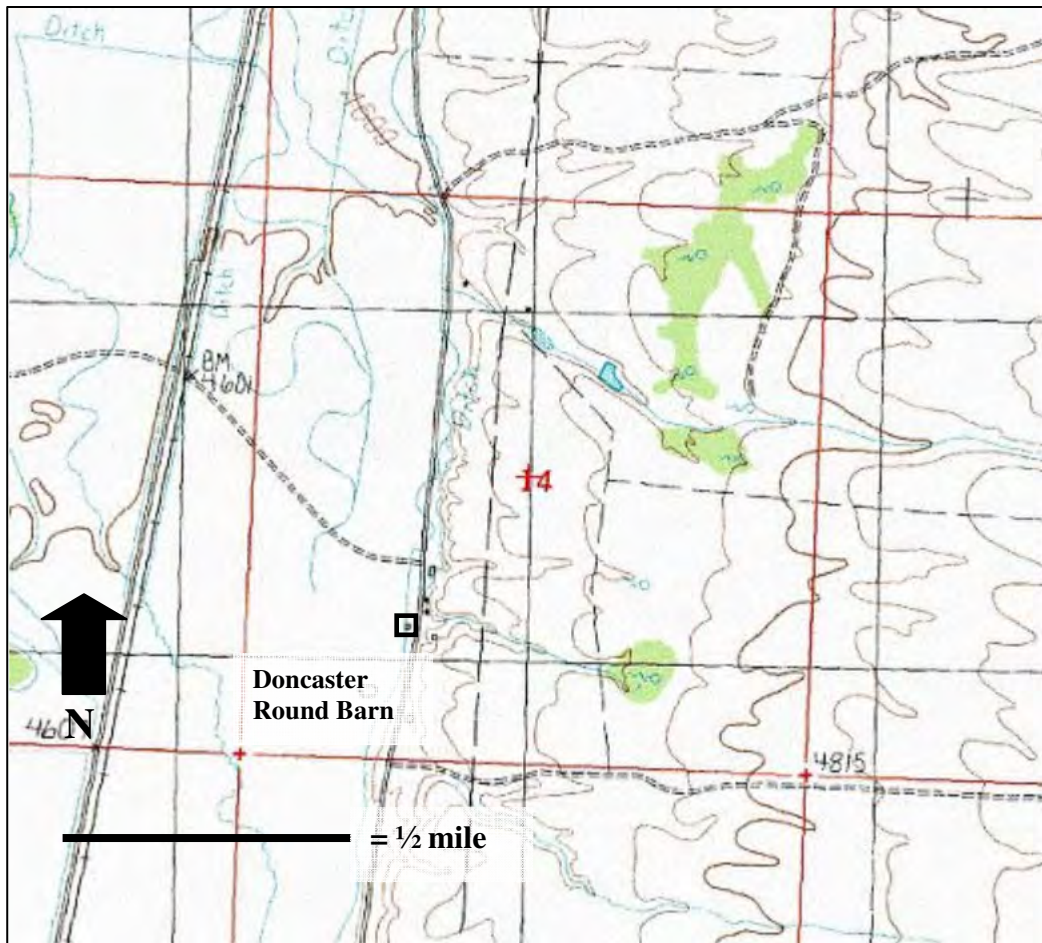

Location of the Doncaster Round Barn (Close up). Found on the Twin Bridges 7.5' USGS Quadrangle Provisional Edition Map, (1989). T3S R6W Section 14.

United States Department of the Interior
National Park Service

National Register of Historic Places Continuation Sheet

Doncaster Round Barn
Name of Property
Madison County, Montana
County and State
Name of multiple listing (if applicable)

Section number Maps and floorplans

Page 22

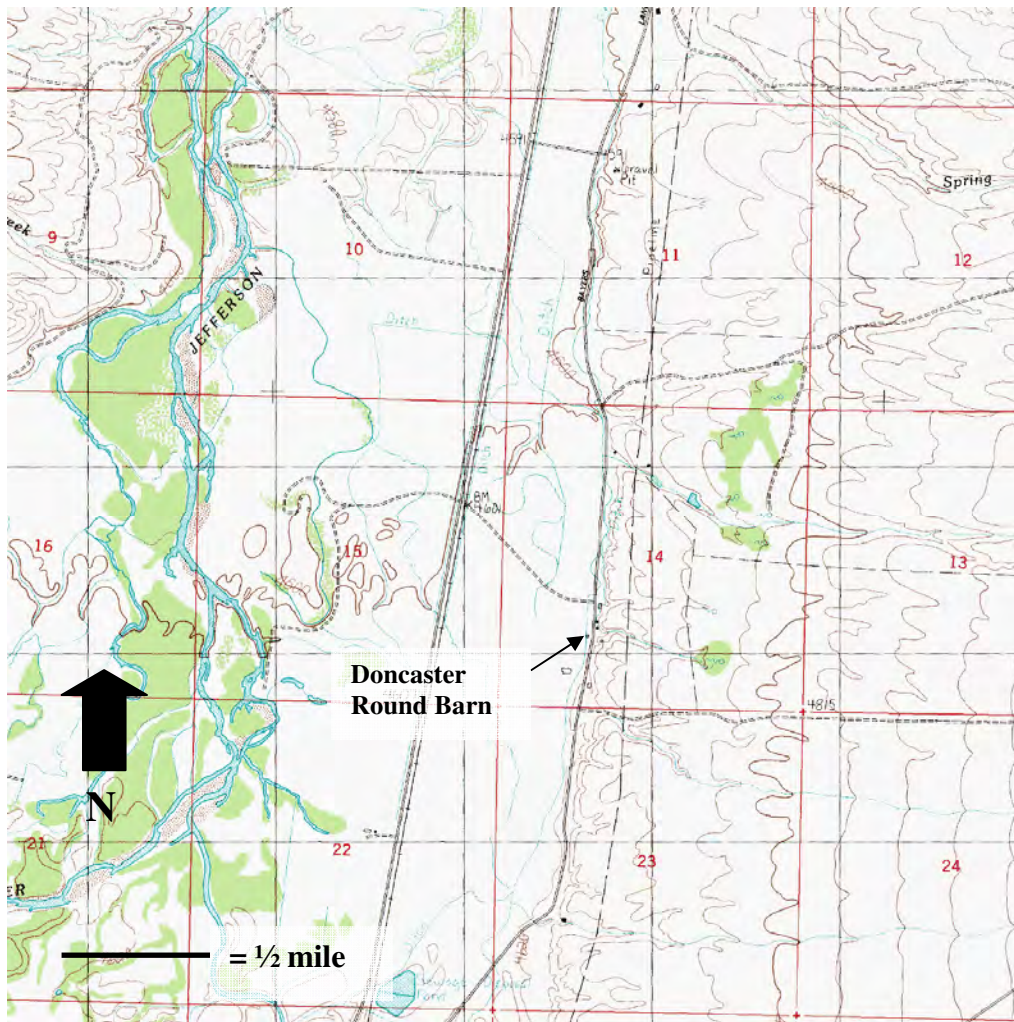

Location of the Doncaster Round Barn showing surrounding area. Found on the Twin Bridges 7.5' USGS Quadrangle Provisional Edition Map, (1989). T3S R6W Section 14.

United States Department of the Interior
National Park Service

**National Register of Historic Places
Continuation Sheet**

Doncaster Round Barn
----- Name of Property
Madison County, Montana
----- County and State
----- Name of multiple listing (if applicable)

Section number Maps and floorplans

Page 23



Aerial View of the Doncaster Round Barn.

United States Department of the Interior
National Park Service

National Register of Historic Places
Continuation Sheet

Doncaster Round Barn
----- Name of Property
Madison County, Montana
----- County and State
----- Name of multiple listing (if applicable)

Section number Maps and floorplans

Page 24

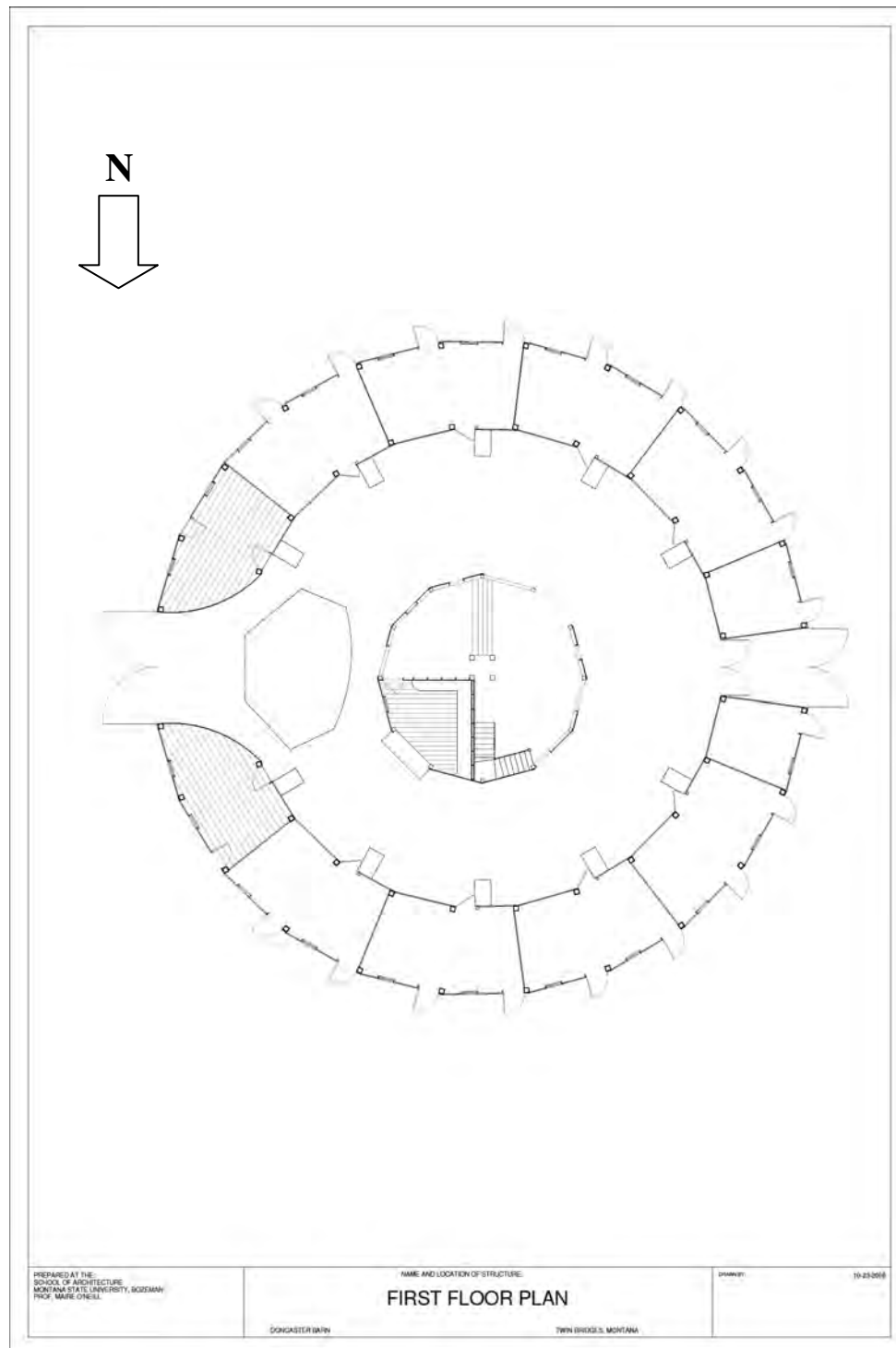

United States Department of the Interior
National Park Service

National Register of Historic Places
Continuation Sheet

Doncaster Round Barn
----- Name of Property
Madison County, Montana
----- County and State
----- Name of multiple listing (if applicable)

Section number Maps and floorplans

Page 25

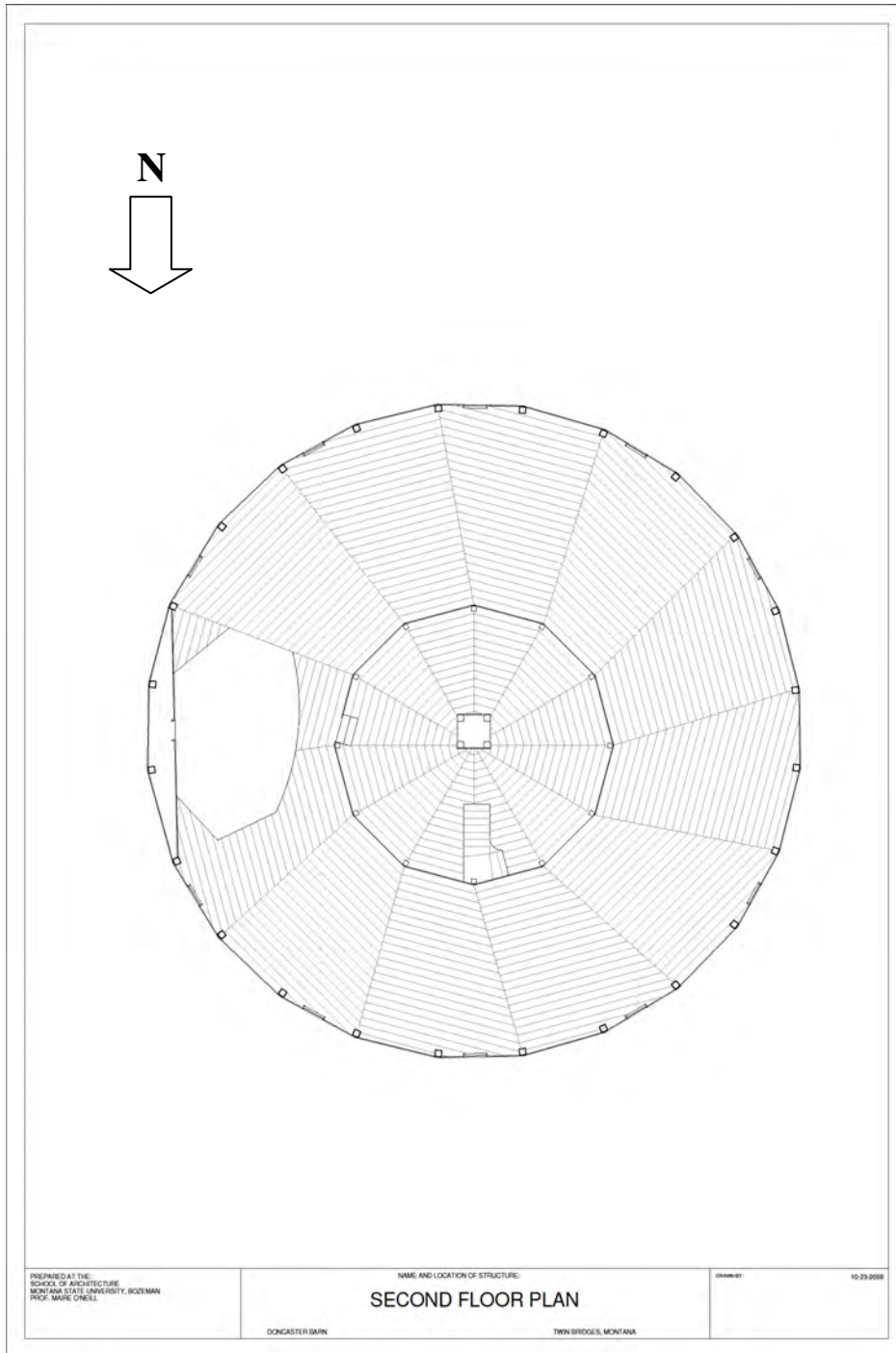

United States Department of the Interior
National Park Service

National Register of Historic Places
Continuation Sheet

Doncaster Round Barn
----- Name of Property
Madison County, Montana
----- County and State
----- Name of multiple listing (if applicable)

Section number Maps and floorplans

Page 26

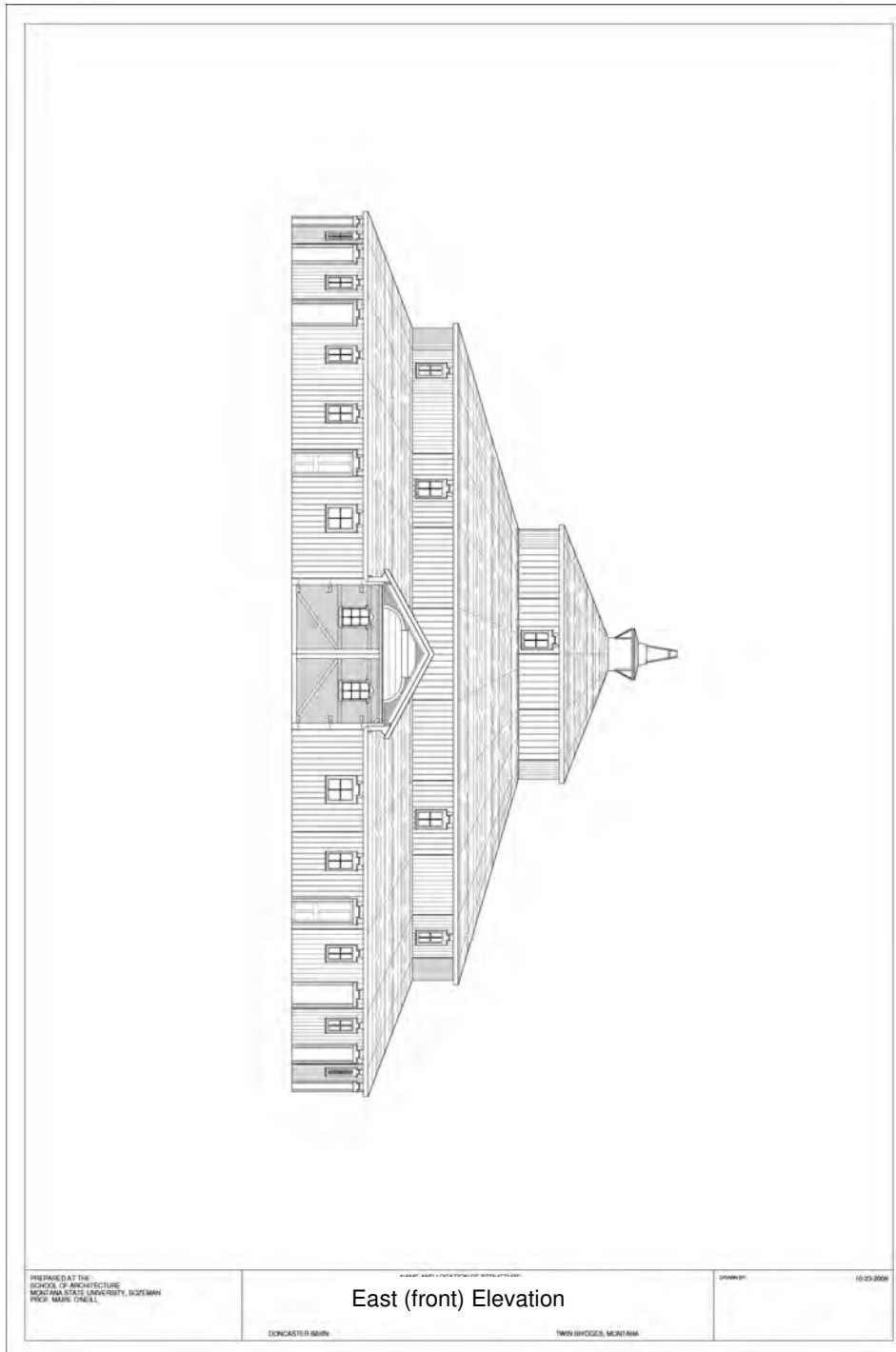

United States Department of the Interior
National Park Service

**National Register of Historic Places
Continuation Sheet**

Doncaster Round Barn

Name of Property

Madison County, Montana

County and State

Name of multiple listing (if applicable)

Section number National Register Photographs

Page 27

Photograph Log

Name: Doncaster Round Barn
County and State: Madison County, Montana
Photographer: Kate Hampton
Date of Photograph: June 2012
Location of original negative: Hamilton Ranch. Twin Bridges, Montana
Description and view of camera: Façade of barn. View to the west.
Photograph: 0001
MT_MadisonCounty_Doncaster Round Barn_0001

Name: Doncaster Round Barn
County and State: Madison County, Montana
Photographer: Jon Axline
Date of Photograph: September 2014
Location of original negative: Hamilton Ranch. Twin Bridges, Montana.
Description and view of camera: Façade of barn. View to the west.
Photograph: 0002
MT_MadisonCounty_Doncaster Round Barn_0002

Name: Doncaster Round Barn
County and State: Madison County, Montana
Photographer: Jon Axline
Date of Photograph: September 2014
Location of original negative: Hamilton Ranch. Twin Bridges, Montana.
Description and view of camera: Façade and north elevation. View to the south.
Photograph: 0003
MT_MadisonCounty_Doncaster Round Barn_0003

Name: Doncaster Round Barn
County and State: Madison County, Montana
Photographer: Jon Axline
Date of Photograph: September 2014
Location of original negative: Hamilton Ranch. Twin Bridges, Montana.
Description and view of camera: North elevation. View to the south.
Photograph: 0004
MT_MadisonCounty_Doncaster Round Barn_0004

United States Department of the Interior
National Park Service

**National Register of Historic Places
Continuation Sheet**

Doncaster Round Barn

Name of Property

Madison County, Montana

County and State

Name of multiple listing (if applicable)

Section number National Register Photographs

Page 28

Name: Doncaster Round Barn
County and State: Madison County, Montana
Photographer: Jon Axline
Date of Photograph: September 2014
Location of original negative: Hamilton Ranch. Twin Bridges, Montana
Description and view of camera: West façade and west entry. View to the east.
Photograph: 0005
MT_MadisonCounty_Doncaster Round Barn_0005

Name: Doncaster Round Barn
County and State: Madison County, Montana
Photographer: Jon Axline
Date of Photograph: September 2014
Location of original negative: Hamilton Ranch. Twin Bridges, Montana.
Description and view of camera: West façade and south elevation. View to the north.
Photograph: 0006
MT_MadisonCounty_Doncaster Round Barn_0006

Name: Doncaster Round Barn
County and State: Madison County, Montana
Photographer: Jon Axline
Date of Photograph: September 2014
Location of original negative: Hamilton Ranch. Twin Bridges, Montana.
Description and view of camera: South elevation. View to the north.
Photograph: 0007
MT_MadisonCounty_Doncaster Round Barn_0007

Name: Doncaster Round Barn
County and State: Madison County, Montana
Photographer: Jon Axline
Date of Photograph: September 2014
Location of original negative: Hamilton Ranch. Twin Bridges, Montana.
Description and view of camera: East facade. View to the west-southwest.
Photograph: 0008
MT_MadisonCounty_Doncaster Round Barn_0008

United States Department of the Interior
National Park Service

**National Register of Historic Places
Continuation Sheet**

Doncaster Round Barn

Name of Property

Madison County, Montana

County and State

Name of multiple listing (if applicable)

Section number National Register Photographs

Page 29

Name: Doncaster Round Barn
County and State: Madison County, Montana
Photographer: Kate Hampton
Date of Photograph: June 2012
Location of original negative: Hamilton Ranch. Twin Bridges, Montana
Description and view of camera: Detail of primary entry. View to the west.
Photograph: 0009
MT_MadisonCounty_Doncaster Round Barn_0009

Name: Doncaster Round Barn
County and State: Madison County, Montana
Photographer: Jon Axline
Date of Photograph: September 2014
Location of original negative: Hamilton Ranch. Twin Bridges, Montana.
Description and view of camera: Detail of south elevation. View to the north.
Photograph: 0010
MT_MadisonCounty_Doncaster Round Barn_0010

Name: Doncaster Round Barn
County and State: Madison County, Montana
Photographer: Jon Axline
Date of Photograph: September 2014
Location of original negative: Hamilton Ranch. Twin Bridges, Montana.
Description and view of camera: Detail of southeast elevation. View to the northwest.
Photograph: 0011
MT_MadisonCounty_Doncaster Round Barn_0011

Name: Doncaster Round Barn
County and State: Madison County, Montana
Photographer: Jon Axline
Date of Photograph: September 2014
Location of original negative: Hamilton Ranch. Twin Bridges, Montana.
Description and view of camera: Detail of west entry. View to the northeast.
Photograph: 0012
MT_MadisonCounty_Doncaster Round Barn_0012

United States Department of the Interior
National Park Service

**National Register of Historic Places
Continuation Sheet**

Doncaster Round Barn

Name of Property

Madison County, Montana

County and State

Name of multiple listing (if applicable)

Section number National Register Photographs

Page 30

Name: Doncaster Round Barn
County and State: Madison County, Montana
Photographer: Jon Axline
Date of Photograph: September 2014
Location of original negative: Hamilton Ranch. Twin Bridges, Montana
Description and view of camera: Detail of finial and third floor window. View to the northwest.
Photograph: 0013
MT_MadisonCounty_Doncaster Round Barn_0013

Name: Doncaster Round Barn
County and State: Madison County, Montana
Photographer: Kate Hampton
Date of Photograph: June 2012
Location of original negative: Hamilton Ranch. Twin Bridges, Montana.
Description and view of camera: Interior detail of second floor balcony railing and ceiling joists.
Photograph: 0014
MT_MadisonCounty_Doncaster Round Barn_0014

Name: Doncaster Round Barn
County and State: Madison County, Montana
Photographer: Jon Axline
Date of Photograph: September 2014
Location of original negative: Hamilton Ranch. Twin Bridges, Montana.
Description and view of camera: Interior detail of ceiling joists
Photograph: 0015
MT_MadisonCounty_Doncaster Round Barn_0015

Name: Doncaster Round Barn
County and State: Madison County, Montana
Photographer: Jon Axline
Date of Photograph: September 2014
Location of original negative: Hamilton Ranch. Twin Bridges, Montana.
Description and view of camera: Second floor showing grain distribution system at window.
Photograph: 0016
MT_MadisonCounty_Doncaster Round Barn_0016

United States Department of the Interior
National Park Service

**National Register of Historic Places
Continuation Sheet**

Doncaster Round Barn

Name of Property

Madison County, Montana

County and State

Name of multiple listing (if applicable)

Section number National Register Photographs

Page 31

Name: Doncaster Round Barn
County and State: Madison County, Montana
Photographer: Jon Axline
Date of Photograph: September 2014
Location of original negative: Hamilton Ranch. Twin Bridges, Montana
Description and view of camera: Detail showing staircase to second floor.
Photograph: 0017
MT_MadisonCounty_Doncaster Round Barn_0017

Name: Doncaster Round Barn
County and State: Madison County, Montana
Photographer: Jon Axline
Date of Photograph: September 2014
Location of original negative: Hamilton Ranch. Twin Bridges, Montana.
Description and view of camera: Interior view of primary entry.
Photograph: 0018
MT_MadisonCounty_Doncaster Round Barn_0018

Name: Doncaster Round Barn
County and State: Madison County, Montana
Photographer: Jon Axline
Date of Photograph: September 2014
Location of original negative: Hamilton Ranch. Twin Bridges, Montana.
Description and view of camera: Interior view of stalls and exercise track.
Photograph: 0019
MT_MadisonCounty_Doncaster Round Barn_0019

Name: Doncaster Round Barn
County and State: Madison County, Montana
Photographer: Lacey Edmundson
Date of Photograph: September 2014
Location of original negative: Hamilton Ranch. Twin Bridges, Montana.
Description and view of camera: "Horse Fair" wood carving that once adorned façade gable end.
Photograph: 0020
MT_MadisonCounty_Doncaster Round Barn_0020

United States Department of the Interior
National Park Service

**National Register of Historic Places
Continuation Sheet**

Doncaster Round Barn

Name of Property

Madison County, Montana

County and State

Name of multiple listing (if applicable)

Section number National Register Photographs

Page 32



Photo 0001. Façade of Doncaster Round Barn. View to the west.

United States Department of the Interior
National Park Service

**National Register of Historic Places
Continuation Sheet**

Doncaster Round Barn

Name of Property

Madison County, Montana

County and State

Name of multiple listing (if applicable)

Section number National Register Photographs

Page 33



Photo 0002. Façade of barn. View to the west.

United States Department of the Interior
National Park Service

**National Register of Historic Places
Continuation Sheet**

Doncaster Round Barn

Name of Property

Madison County, Montana

County and State

Name of multiple listing (if applicable)

Section number National Register Photographs

Page 34



Photo 0003. Façade and north elevation of barn. View to the south.

United States Department of the Interior
National Park Service

**National Register of Historic Places
Continuation Sheet**

Doncaster Round Barn

Name of Property

Madison County, Montana

County and State

Name of multiple listing (if applicable)

Section number National Register Photographs

Page 35



Photo 0004. North elevation of barn. View to the south.

United States Department of the Interior
National Park Service

**National Register of Historic Places
Continuation Sheet**

Doncaster Round Barn

Name of Property

Madison County, Montana

County and State

Name of multiple listing (if applicable)

Section number National Register Photographs

Page 36



Photo 0005. West façade and west entry of barn. View to the east.

United States Department of the Interior
National Park Service

**National Register of Historic Places
Continuation Sheet**

Doncaster Round Barn

Name of Property

Madison County, Montana

County and State

Name of multiple listing (if applicable)

Section number National Register Photographs

Page 37



Photo 0006. West façade and south elevation. View to the north.

United States Department of the Interior
National Park Service

**National Register of Historic Places
Continuation Sheet**

Doncaster Round Barn

Name of Property

Madison County, Montana

County and State

Name of multiple listing (if applicable)

Section number National Register Photographs

Page 38



Photo 0007. South elevation of barn. View to the north.

United States Department of the Interior
National Park Service

**National Register of Historic Places
Continuation Sheet**

Doncaster Round Barn

Name of Property

Madison County, Montana

County and State

Name of multiple listing (if applicable)

Section number National Register Photographs

Page 39



Photo 0008. East facade. View to the west-southwest.

United States Department of the Interior
National Park Service

**National Register of Historic Places
Continuation Sheet**

Doncaster Round Barn

Name of Property

Madison County, Montana

County and State

Name of multiple listing (if applicable)

Section number National Register Photographs

Page 40



Photo 0009. Detail of primary entry of barn. View to the west.

United States Department of the Interior
National Park Service

**National Register of Historic Places
Continuation Sheet**

Doncaster Round Barn

Name of Property

Madison County, Montana

County and State

Name of multiple listing (if applicable)

Section number National Register Photographs

Page 41



Photo 0010. Detail of south elevation of barn. View to the north.

United States Department of the Interior
National Park Service

**National Register of Historic Places
Continuation Sheet**

Doncaster Round Barn

Name of Property

Madison County, Montana

County and State

Name of multiple listing (if applicable)

Section number National Register Photographs

Page 42



Photo 0011. Detail of southeast elevation. View to the northwest.

United States Department of the Interior
National Park Service

**National Register of Historic Places
Continuation Sheet**

Doncaster Round Barn

Name of Property

Madison County, Montana

County and State

Name of multiple listing (if applicable)

Section number National Register Photographs

Page 43



Photo 0012. Detail of west entry to barn. View to the northeast.

United States Department of the Interior
National Park Service

**National Register of Historic Places
Continuation Sheet**

Doncaster Round Barn

Name of Property

Madison County, Montana

County and State

Name of multiple listing (if applicable)

Section number National Register Photographs

Page 44



Photo 0013. Detail of finial and third floor window. View to the northwest.

United States Department of the Interior
National Park Service

**National Register of Historic Places
Continuation Sheet**

Doncaster Round Barn

Name of Property

Madison County, Montana

County and State

Name of multiple listing (if applicable)

Section number National Register Photographs

Page 45



Photo 0014. Interior detail of second floor balcony railing and ceiling joists.

United States Department of the Interior
National Park Service

National Register of Historic Places
Continuation Sheet

Doncaster Round Barn

Name of Property

Madison County, Montana

County and State

Name of multiple listing (if applicable)

Section number National Register Photographs

Page 46



Photo 0015. Interior detail of ceiling joists.

United States Department of the Interior
National Park Service

**National Register of Historic Places
Continuation Sheet**

Doncaster Round Barn

Name of Property

Madison County, Montana

County and State

Name of multiple listing (if applicable)

Section number National Register Photographs

Page 47



Photo 0016. Second floor showing grain distribution system at window.

United States Department of the Interior
National Park Service

**National Register of Historic Places
Continuation Sheet**

Doncaster Round Barn

Name of Property

Madison County, Montana

County and State

Name of multiple listing (if applicable)

Section number National Register Photographs

Page 48



Photo 0017. Detail showing staircase to second floor.

United States Department of the Interior
National Park Service

**National Register of Historic Places
Continuation Sheet**

Doncaster Round Barn

Name of Property

Madison County, Montana

County and State

Name of multiple listing (if applicable)

Section number National Register Photographs

Page 49



Photo 0018. Interior view of primary entry.

United States Department of the Interior
National Park Service

**National Register of Historic Places
Continuation Sheet**

Doncaster Round Barn

Name of Property

Madison County, Montana

County and State

Name of multiple listing (if applicable)

Section number National Register Photographs

Page 50



Photo 0019. Interior view of stalls and exercise track.

United States Department of the Interior
National Park Service

**National Register of Historic Places
Continuation Sheet**

Doncaster Round Barn

Name of Property

Madison County, Montana

County and State

Name of multiple listing (if applicable)

Section number National Register Photographs

Page 51



Photo 0020. "Horse Fair" wood carving that once adorned façade gable end.





CONSTRUCTION
DESIGN

(406) 685-5423

Quality Comes First!





































UNITED STATES DEPARTMENT OF THE INTERIOR
NATIONAL PARK SERVICE

NATIONAL REGISTER OF HISTORIC PLACES
EVALUATION/RETURN SHEET

REQUESTED ACTION: NOMINATION

PROPERTY Doncaster Round Barn
NAME:

MULTIPLE
NAME:

STATE & COUNTY: MONTANA, Madison

DATE RECEIVED: 2/27/15 DATE OF PENDING LIST: 3/30/15
DATE OF 16TH DAY: 4/14/15 DATE OF 45TH DAY: 4/14/15
DATE OF WEEKLY LIST:

REFERENCE NUMBER: 15000150

REASONS FOR REVIEW:

APPEAL: N DATA PROBLEM: N LANDSCAPE: N LESS THAN 50 YEARS: N
OTHER: N PDIL: N PERIOD: N PROGRAM UNAPPROVED: N
REQUEST: N SAMPLE: N SLR DRAFT: N NATIONAL: N

COMMENT WAIVER: N

ACCEPT RETURN REJECT 4.14.15 DATE

ABSTRACT/SUMMARY COMMENTS:

Entered in
The National Register
of
Historic Places

RECOM./CRITERIA _____

REVIEWER _____ DISCIPLINE _____

TELEPHONE _____ DATE _____

DOCUMENTATION see attached comments Y/N see attached SLR Y/N

If a nomination is returned to the nominating authority, the nomination is no longer under consideration by the NPS.



February 20, 2015

J. Paul Loether, Deputy Keeper and Chief, National Register and National Historic Landmark Programs National Park Service
1201 Eye St. NW
8th Floor (MS 2280)
Washington, D.C. 20005

Dear Mr. Loether,

Enclosed please find the following nomination for your consideration for listing in the National Register of Historic Places:

The Doncaster Round Barn,

Madison County, Montana

The enclosed disks contain the true and correct copy of the National Register nomination for the Doncaster Round Barn to the National Register of Historic Places.

Please be advised that I submit the enclosed nomination under your revised procedures. I notified the owners and public officials in excess of 30 days prior to the Preservation Review Board meeting and received no notarized objections to the nomination from the property owners of record. The Review Board unanimously recommended that this property be nominated and I concur with its recommendation.

Thank you for your consideration.

Sincerely,

A handwritten signature in blue ink that reads "Mark Bumler".

Mark Bumler, PhD
State Historic Preservation Officer

Enclosure