

United States Department of the Interior
National Park Service

National Register of Historic Places Continuation Sheet

Name of Property

County and State

Name of multiple property listing (if applicable)

Section number _____ Page _____

SUPPLEMENTARY LISTING RECORD

NRIS Reference Number: 100001461

Date Listed: 8/11/2017

Property Name: Chatuge Hydroelectric Project (Historic Resources of the TVA Hydroelectric Project)

County: Clay

State: NC

This property is listed in the National Register of Historic Places in accordance with the attached nomination documentation subject to the following exceptions, exclusions, or amendments, notwithstanding the National Park Service certification included in the nomination documentation.

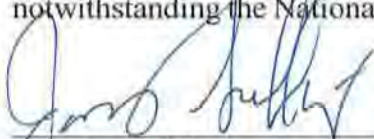

Signature of the Keeper

8.11.2017

Date of Action

Amended Items in Nomination:

Section 8:

This SLR seeks to clarify the level of significance. The Hiwassee Hydroelectric Project is significant at the local and state levels. National significance for this dam and project is not justified.

The property is significant in ENGINEERING under Criterion C, and in RECREATION under Criterion A.

The TVA FPO and North Carolina SHPO were notified of this amendment.

DISTRIBUTION:

National Register property file
Nominating Authority (without nomination attachment)

United States Department of the Interior
National Park Service

MP-1461

National Register of Historic Places Registration Form

This form is for use in nominating or requesting determinations for individual properties and districts. See instructions in National Register Bulletin, *How to Complete the National Register of Historic Places Registration Form*. If any item does not apply to the property being documented, enter "N/A" for "not applicable." For functions, architectural classification, materials, and areas of significance, enter only categories and subcategories from the instructions.



1. Name of Property

Historic name: Chatuge Hydroelectric Project

Other names/site number: Chatuge Dam

Name of related multiple property listing:

Historic Resources of the Tennessee Valley Authority Hydroelectric Project, 1933-1979

(Enter "N/A" if property is not part of a multiple property listing)

2. Location

Street & number: 221 Old Ranger Road

City or town: Hayesville State: NC County: Clay

Not For Publication: Vicinity:

3. State/Federal Agency Certification

As the designated authority under the National Historic Preservation Act, as amended,

I hereby certify that this nomination request for determination of eligibility meets the documentation standards for registering properties in the National Register of Historic Places and meets the procedural and professional requirements set forth in 36 CFR Part 60.

In my opinion, the property meets does not meet the National Register Criteria. I recommend that this property be considered significant at the following level(s) of significance:

national statewide local

Applicable National Register Criteria:

A B C D

<u><i>Patricia B. Eggell / Sr. Proj. Mgr. & FPO</i></u>	<u>6-19-17</u>
Signature of certifying official/Title:	Date
<u>Tennessee Valley Authority</u>	
State or Federal agency/bureau or Tribal Government	

In my opinion, the property meets does not meet the National Register criteria.

Kevin Cherry 4/13/16

Signature of commenting official:

Date

State Historic Preservation Officer North Carolina Department of Natural and Cultural Resources

Title :

State or Federal agency/bureau
or Tribal Government

Chatuge Hydroelectric Project
Name of Property

Clay, NC
County and State

4. National Park Service Certification

I hereby certify that this property is:

- entered in the National Register
- determined eligible for the National Register
- determined not eligible for the National Register
- removed from the National Register
- other (explain:)

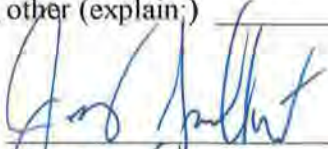
Signature of the Keeper
For

8-11-2017
Date of Action

5. Classification

Ownership of Property

(Check as many boxes as apply.)

- Private:
- Public – Local
- Public – State
- Public – Federal

Category of Property

(Check only **one** box.)

- Building(s)
- District
- Site
- Structure
- Object

Chatuge Hydroelectric Project
Name of Property

Clay, NC
County and State

Number of Resources within Property

(Do not include previously listed resources in the count)

Contributing	Noncontributing	
<u>3</u>	<u>1</u>	buildings
<u>2</u>	<u>0</u>	sites
<u>4</u>	<u>1</u>	structures
<u>0</u>	<u>0</u>	objects
<u>9</u>	<u>2</u>	Total

Number of contributing resources previously listed in the National Register N/A

6. Function or Use

Historic Functions

(Enter categories from instructions.)

PROCESSING/ *Energy Facility*

RECREATION AND CULTURE/ *Outdoor Recreation*

Current Functions

(Enter categories from instructions.)

PROCESSING/ *Energy Facility*

RECREATION AND CULTURE/ *Outdoor Recreation*

Chatuge Hydroelectric Project
Name of Property

Clay, NC
County and State

7. Description

Architectural Classification

(Enter categories from instructions.)

NO STYLE
OTHER/Hydroelectric Dam

Materials: (enter categories from instructions.)

Principal exterior materials of the property: Concrete, Steel, Rock, Earth

Narrative Description

(Describe the historic and current physical appearance and condition of the property. Describe contributing and noncontributing resources if applicable. Begin with a **summary paragraph** that briefly describes the general characteristics of the property, such as its location, type, style, method of construction, setting, size, and significant features. Indicate whether the property has historic integrity.)

Construction of the Chatuge Hydroelectric Project began in 1941 and was completed in 1942, with the addition of hydroelectric equipment and facilities in 1954.¹ The Chatuge project is located at mile 121 on the Hiwassee River, three miles southeast of Hayesville (pop. 311 in 2010), the seat of Clay County and two miles north of the Georgia state line. The Chatuge dam impounds the Chatuge Reservoir (also called Lake Chatuge), which extends thirteen miles south along the Hiwassee River and six miles east along Shooting Creek. The reservoir has a storage capacity of 62,600 acre-feet.² The reservoir has 132 miles of shoreline in Towns County, Georgia, and Clay County, North Carolina. Chatuge Reservoir is a 7,000 acre impoundment of the Hiwassee River with portions lying within the Nantahala National Forest in North Carolina and the Chattahoochee National Forest in Georgia. From the Chatuge Dam, the Hiwassee River flows north and west through North Carolina and into the Tennessee River in Meigs County, Tennessee. The Chatuge Project takes its name from an eighteenth-century Cherokee village that was once located near the project site.³

¹ Tennessee Valley Authority, "Chatuge Reservoir," at webpage <http://www.tva.gov/sites/chatuge.htm> accessed August 4, 2015.

² Tennessee Valley Authority, "Civil and Structural Design," (Knoxville: Tennessee Valley Authority, 1952), 13.

³ Ibid.

Chatuge Hydroelectric Project
Name of Property

Clay, NC
County and State

INVENTORY

The Chatuge Hydroelectric Project originally consisted of the main embankment (earthen dam) across the river valley, an intake tower above the dam and a valve building below the dam (*see Photo 1*). In 1954, the single hydroelectric unit was added, along with a powerhouse and a switchyard with transmission lines. Since completion of the original project, other buildings and structures have been added to the property. The 508-acre nominated area includes all the above structures and buildings, a portion of the Chatuge Reservoir, and roads that access both the hydroelectric facilities in the center of the property and recreational points of visitation at the east and west ends. Chatuge Dam Road enters from the northwest to access the dam and continues to the west along the reservoir to join with a visitor parking lot at Myers Chapel Road just outside the boundary). The eastern recreational point is accessed by The Cir, a road within the boundary that intersects with Hinton Center Road, which enters the eastern boundary from the northwest.

1. Chatuge Dam and Spillway, 1942 (Contributing Structure)

The Chatuge Hydroelectric Project's dam (*see Photos 2-7*) is embankment across the natural river channel. It is constructed of rolled earth fill with riprap on the face of the upstream slope and grass on the downstream slope. The foundation rests on gneiss metamorphic rock. Its total crest length is 3,336 feet with a maximum height of 150 feet and a maximum width of 980 feet at the base. The top of the embankment is at elevation 1,940 feet. Running most of the length of the embankment is a sixteen-foot wide road, used as a walking trail for the public, as well as a road for maintenance of the intake structure.⁴

The spillway is around the east bend of the embankment and is on the right (east) bank of the river. The spillway is a chute type spillway and has a long, circular crest of 325 feet with an arched control weir gate. At the top of the crest are vertical steel beams approximately six feet apart, which serve as flashboard units at the crest storing water along the crest at four feet deep.⁵ These flashboards can be removed by a hand-operated hoist traveling along a footbridge at the crest. From the weir control gate, the spillway's five-foot side walls converge into a straight channel ninety feet wide and 1,356 feet long. The concrete floor of the spillway is constructed of nine-inch thick concrete and slopes down to thirty-five feet above the normal water level. The spillway floor is divided into sections by contraction joints constructed of copper strips and asphalt filler material. Discharge from the spillway occurs 3,000 feet below the dam into the river. As the water travels down the spillway, it accelerates in speed, requiring a steadily diminishing width as it proceeds.⁶

⁴ Tennessee Valley Authority, "Mechanical Design of Hydro Plants," (Knoxville: Tennessee Valley Authority, 1960), 281.

⁵ Tennessee Valley Authority, "Civil and Structural Design," 300.

⁶ *Ibid*, 62.

Chatuge Hydroelectric Project
Name of Property

Clay, NC
County and State

2. Powerhouse, 1954 (Contributing Building)

The Chatuge powerhouse (*see Photos 8-15*) is constructed of steel and reinforced concrete. The principal dimensions of the building are thirty-six feet in length by seventy-nine feet, six inches in width by sixty feet in height. A fifty-seven-ton derrick crane is installed on the roof of the powerhouse for the erection and maintenance of the single hydroelectric generating unit.⁷ The powerhouse's exterior concrete walls are sectioned into rectangular panels with wood board impressions from construction. The powerhouse is an outdoor type and has one generating unit. The main entrance has paired steel doors on the east elevation with an aluminum curved awning above. This level is the main deck that accesses the top of the generator on the north elevation. The south elevation has one original, exterior, steel door with a curved aluminum awning, as well as a steel staircase to the rooftop crane. The north and west elevations lack fenestration. On top of the generator bay is the large cylindrical metal cover which houses the turbine unit. The north elevation of the generator bay contains the sluice gates.

The main level of the powerhouse contains the control room, which displays linoleum flooring, concrete ceilings and walls, and all control panels for the generator and switchyard. There is a restroom on this level which has original concrete walls and ceiling. The first floor is connected to the generator room below via a concrete staircase which has a steel handrail. The generator room contains the generator wheel pit access and machine shop. The generator room also has concrete floors, ceilings, and walls. The single Francis type turbine was manufactured in 1954 by James Leffel and Company in Springfield, Ohio. The turbine is rated at 13,800 horsepower with a net head of 100 feet and operates at a speed of 180 revolutions per minute. The Westinghouse Electric Corporation generator operates at 11,111 kilovolt-amperes at 0.9 power factor, 6,900 volts, three phase, sixty cycles, and operates at 180 revolutions per minute.⁸

3. Powerhouse Storage Building, 1954 (Contributing Building)

To the east of the powerhouse is a one-story, rectangular building used for storage (*see Photos 16 & 17*). This building is constructed of poured concrete panels with board impressions and has a flat, concrete roof. The west elevation has original paired solid steel doors with a curved aluminum awning above. There are no other fenestration or door openings on any other elevation.

4. Powerhouse Equipment Shed, ca. 1990 (Non-Contributing Building)

This is a ca. 1990 equipment shed with aluminum siding and a flat metal roof. This shed has twelve bays with aluminum overhead track, garage bay doors (*see Photo 18*).

5. Intake, 1942 (Contributing Structure)

The intake (*see Photos 19 & 20*) at Chatuge is located above the dam. It is a concrete tower that consists of a twenty-five-foot diameter vertical shaft extending above the reservoir level. The height of the intake tower is 175 feet.⁹ A trashrack is located at the waterway entrance at the base

⁷ Tennessee Valley Authority, "Mechanical Design of Hydro Plants," 284.

⁸ Ibid, 285.

⁹ Tennessee Valley Authority, "Civil and Structural Design," 361.

Chatuge Hydroelectric Project

Name of Property

Clay, NC

County and State

of the tower. Located behind the trashrack and at the bottom of the tower, are two side-by-side hydraulically operated slide gates to close off water for maintenance and inspection of the penstock. The gates at the upstream entrance to the intake tower act as emergency gates. The tower is accessed from the top of the dam by a steel footbridge. Starting at the base of the intake tower is a concrete culvert constructed at the initiation of the dam construction to divert water from the project site, the culvert extends 770 feet along the dam. This concrete culvert was later developed into a conduit with a twelve-foot diameter steel penstock. This penstock now connects the intake and the generating unit at the powerhouse. A seventy-eight-inch Howell-Bunger valve was located on the downstream side of the penstock to allow water discharge without generating power.¹⁰ The valve also contains an eighteen-inch bypass line around the valve. An outlet conduit was installed once the power generator was installed at the powerhouse. The water pipe connected to this outlet conduit carries a water load of 1,550 cubic feet per second. The crane house is the overhang structure on the north side of the intake tower. This crane house contains a fifteen-ton crane for carrying and picking up supplies and equipment for regular maintenance.¹¹

6. Switchyard and Transmission Lines, 1954 (Contributing Structure)

The switchyard (*see Photos 21 & 22*) is located east of the powerhouse and was built in 1954 as part of the project to install the single generator. The switchyard is located within a rectangular enclosure and is surrounded by a chain link fence. The generators and switching units rest on a concrete foundation. There are is a single-station service transformer rated at 500 kVA, 13.8 kV480 V. Steel transmission lines are located to the south of the powerhouse and carry power west across the Hiwassee River towards the city of Hayesville.

7. Weir Dam, 1992 (Non-Contributing Structure)

In 1992, TVA built an infuser weir dam below Chatuge Dam (*see Photos 23 & 24*). The weir dam was initially constructed to provide a steady flow of water to the Hiwassee riverbed and enhance oxygen levels for aquatic life.¹² The added oxygen is needed to sustain fish populations, as the creation of a still body of water is not natural for the native river species found here. The weir dam is constructed of a timber crib filled with loose rocks and lined with tongue and groove timbers along its upstream face. The infuser deck has steel grates spaced between timbers. The steel grates break up falling sheets of water, and the water gains oxygen in plunging over the seven-and-one-half-foot dam wall. Located at the weir dam is a parking lot and pedestrian landing to overlook the dam.

8. Chatuge Picnic Recreation Area, 1954 (Contributing Site)

TVA developed a picnic area, boat ramp, and overlook area on the upstream side of the dam embankment to the east of the dam and powerhouse (*see Photos 25 & 26*). The picnic area consists of a grass and wooded lot, interspersed with original concrete picnic tables on concrete pads. The boat ramp consists of a poured concrete and aggregate underwater ramp with concrete slope sidewalls. The TVA developed a small overlook area in between the east embankment of

¹⁰ Ibid.

¹¹ Ibid.

¹² "Chatuge Reservoir," at webpage <http://www.tva.gov/sites/chatuge.htm> accessed August 4, 2015.

Chatuge Hydroelectric Project
Name of Property

Clay, NC
County and State

the dam and the spillway crest. This overlook area consists of a parking lot for pedestrians to use the trail across the dam, a static display of a hydroelectric generating turbine wheel, and a TVA metal plaque depicting the location of all TVA dams within the Tennessee Valley watershed.

Recreational Area 2 resources (see Photos 27 & 28):

9. Gibson Cove Campground, 1954 (Contributing Site)

To the west of the upstream side of the dam, TVA developed a campground area consisting of a campground, bath house, swimming beach, and boat ramp with parking. The campground area consists of camper lots, winding roadway throughout the grounds, and a water pumping station. The swimming beach is located within the campground and is a sloped dirt area with a 100-foot by 80-foot swimming area marked off by floating barriers. The boat ramp consists of an asphalt parking lot and concrete and aggregate underwater ramp. Along the left side of the boat ramp is a concrete aggregate sidewalk approximately twelve feet out into the water.

10. Bathhouse, 1954 (Contributing Building)

The campground also includes a one-story bath house, which is a standardized design used throughout TVA's recreational facilities. It has concrete-block walls and a saltbox roof of asphalt shingles. The façade has an integral, recessed entrance with solid steel doors. The gable end elevations have asymmetrical fixed windows.

11. Hiwassee River Bridge, Chatuge Dam Road, 1922 (Contributing Structure)

The Chatuge Dam Road provides access to the project, and a concrete-beam bridge crosses the Hiwassee River just north of the dam and powerhouse (see Photos 29 & 30). This bridge was built by the county in 1922, but was incorporated into the TVA reservation boundary when the dam was built in 1942. The bridge has concrete wing walls, three concrete abutments, and an asphalt surface. The bridge has concrete balusters and railing. The bridge retains a metal plaque listing the name of the county commissioners, the date 1922, and the builder, W.T. Moore Concrete Product Co., of Andrews, North Carolina.

Chatuge Hydroelectric Project
Name of Property

Clay, NC
County and State

8. Statement of Significance

Applicable National Register Criteria

(Mark "x" in one or more boxes for the criteria qualifying the property for National Register listing.)

- A. Property is associated with events that have made a significant contribution to the broad patterns of our history.
- B. Property is associated with the lives of persons significant in our past.
- C. Property embodies the distinctive characteristics of a type, period, or method of construction or represents the work of a master, or possesses high artistic values, or represents a significant and distinguishable entity whose components lack individual distinction.
- D. Property has yielded, or is likely to yield, information important in prehistory or history.

Criteria Considerations

(Mark "x" in all the boxes that apply.)

- A. Owned by a religious institution or used for religious purposes
- B. Removed from its original location
- C. A birthplace or grave
- D. A cemetery
- E. A reconstructed building, object, or structure
- F. A commemorative property
- G. Less than 50 years old or achieving significance within the past 50 years

Chatuge Hydroelectric Project
Name of Property

Clay, NC
County and State

Areas of Significance

(Enter categories from instructions.)

ENGINEERING

RECREATION

Period of Significance

1942-1966

Significant Dates

1942-1954

Significant Person

(Complete only if Criterion B is marked above.)

N/A

Cultural Affiliation

N/A

Architect/Builder

Project: Tennessee Valley Authority

Bridge: W.T. Moore Concrete Product Co., Builder

Statement of Significance Summary Paragraph (Provide a summary paragraph that includes level of significance, applicable criteria, justification for the period of significance, and any applicable criteria considerations.)

The Chatuge Hydroelectric Project meets National Register criterion A for its historical significance and engineering design as an integral part of the Tennessee Valley Authority Hydroelectric Project. The Chatuge Hydroelectric Project is significant in the expansion of energy, and improvement of quality of life through transmission of electricity, control of seasonal flooding, and creation of public recreational facilities. The Chatuge Hydroelectric Project was one of twenty-five dam (25) sites constructed by the Tennessee Valley Authority (TVA) for the purpose of generating electrical power from, improving navigation of, and controlling seasonal flooding of the river system of the region.

Chatuge Hydroelectric Project

Name of Property

Clay, NC

County and State

The Multiple Property Documentation Form, "Historical Resources of the Tennessee Valley Authority Hydroelectric Project, 1933-1979" identifies the property types of powerhouses, dams, navigational locks and lock control buildings, visitor buildings, recreational buildings, maintenance buildings, and other buildings and structures specifically associated with TVA's missions of hydroelectric power, flood control, navigation, improvement of quality of life, and recreation. These common property types can be found at the majority of the TVA's hydroelectric facilities. This collection of identifiable and consistent property types essential to TVA's multi-faceted mission are associated with important developments in the areas of agriculture, architecture, conservation, engineering, industry, military, recreation, social history, and/or transportation. At Chatuge, the specific property types within the proposed boundary convey significance of the project specifically to engineering and recreation.

The main objective of the 1933 Tennessee Valley Authority Act was the creation of a continuously navigable nine-foot channel from the mouth of the Tennessee River to Knoxville, as well as flood control, power generation, and public benefits. The Chatuge project's significance in Criterion A for engineering is reflected in TVA's overall plan for an integrated system of river management through site-specific designs tested on scaled models. The project is significant in recreation because of the outdoor sites it created. The Chatuge Hydroelectric Project was part of a group of four dams built on the Hiwassee River and its tributaries as proposed by TVA in its 1936 report to Congress. The Chatuge Hydroelectric Project meets the registration requirements set forth in the Multiple Property Documentation Form, "Historical Resources of the Tennessee Valley Authority Hydroelectric Project, 1933-1979." While the MPDF's period of significance spans to 1979, in order to include all of the TVA's hydroelectric and dam projects on the main river and its tributaries, the period of significance for the individual nomination of the Chatuge project stops at fifty years ago, to include the largest number of historic resources that have been added since 1954.

Narrative Statement of Significance (Provide at least **one** paragraph for each area of significance.)

The Tennessee Valley Authority (TVA) was created under President Roosevelt's New Deal program as part of his "First One Hundred Days." Roosevelt envisioned "a corporation clothed with the power of government, but possessed of the flexibility and initiative of a private enterprise." To this end, Congress passed the TVA Act on May 18, 1933.¹³ The multi-purpose legislation sought to improve navigation and flood control of the Tennessee River, spur agricultural and industrial development in the Tennessee Valley, and provide for national defense via government facilities in the proximity of Muscle Shoals, Alabama (Sec. 1). The act authorized the TVA Corporation to acquire real estate for the construction of dams, reservoirs, power houses, transmission lines, or navigations projects at any point along the Tennessee River and its tributaries (Sec. 4i).¹⁴

¹³ "History of the Tennessee Valley Authority," at website

http://www.policyalmanac.org/economic/archive/tva_history.shtml accessed August 5, 2015.

¹⁴ Ibid.

Chatuge Hydroelectric Project

Name of Property

Clay, NC

County and State

The Chatuge Hydroelectric Project takes its name from an eighteenth-century Cherokee settlement located near the project site. These Cherokee settlements often served as trading settlements between Cherokee tribes in South Carolina and Tennessee. The Cherokee were forced from the area in the early nineteenth century, while Anglo settlement of the area occurred during mid-nineteenth century. Clay County was officially formed in 1861 from sections of Macon and Cherokee Counties. Hayesville was established as the county seat shortly after, with the construction of the Clay County Courthouse in 1888. The town of Hayesville officially became incorporated in 1913. Evidence and remnants of the former Native American settlements are still evident by way of several Indian mounds located in the area.¹⁵

TVA selected the rural area south of Hayesville as the site for the Chatuge Hydroelectric Project in 1940. The local citizens in the surrounding area of Clay County, North Carolina, and Towns County, Georgia, were concerned that the project would take away productive farmland. Other citizens were concerned that a loss of land taxes from the acquired property would result in a tax increase. Subsequently, TVA created a system for making annual tax payments to affected counties in lieu of land taxes.¹⁶ TVA insisted that the annual payments would add more money to the tax base than what would have been received from land taxes.

The Chatuge project was proposed as part of a collection of dams along the Tennessee River to aid in the World War II emergency efforts to generate significant amounts of electricity for aluminum production. The TVA Board of Directors authorized funding of the project in fiscal year 1941. The timing of initiating construction was based on the release and availability of the Hiwassee project's labor force following its anticipated completion. The TVA formally approved the Chatuge project on July 17, 1941, and the closure of the dam and filling of the reservoir began on February 12, 1942. Unlike other TVA projects during this period, the Chatuge Hydroelectric Project was established strictly for water storage in support of other TVA projects. However, the Chatuge Dam was constructed with the ability to add power generation at a later date. The initial project consisted of a rolled-earth dam, concrete spillway, intake, and valve house. Construction of power generation facilities was not considered economical upon construction in 1942. The TVA Board of Directors eventually approved the addition of a single hydroelectric generating unit to the Chatuge project on September 25, 1951. Construction began on August 14, 1952 including a powerhouse (replacing the valve house), a single generating unit, and switchyard with transmission lines. Commercial operation of the power unit was initiated on December 9, 1954.¹⁷

The TVA requested \$51,000,000 to construct four dams on the Hiwassee, two for power generation and two for water storage. The Chatuge project was part of this group of four, and in 1941, \$4,949,251 was used for direct construction costs, including labor, materials, equipment, construction plant, tools, warehouse charges and transportation. Indirect construction costs,

¹⁵ "A History of Clay County," at website http://www.carolana.com/NC/Counties/clay_county_nc.html accessed August 5, 2015.

¹⁶ Sawyer, "Northeast Georgia: A History," (Charleston, SC: Arcadia Publishing, 2001), 140.

¹⁷ Tennessee Valley Authority, "Mechanical Design of Hydro Plants," 281.

Chatuge Hydroelectric Project

Clay, NC

Name of Property

County and State

including accounting, timekeeping, office supplies, and security services, amounted to \$241,984. Design and engineering expenditures, which included salaries and expense of executive engineers, technicians, and inspectors, amounted to \$693,589.¹⁸ These amounts plus other categorized costs brought the total project to \$7,036,526. The additional construction of a powerhouse, switchyard, and transmission lines amounted to \$2,246,375. The total project costs for Chatuge Hydroelectric Project totaled \$9,285,901.¹⁹

Total payroll count peaked at approximately 2,200 workers at the end of 1941. After the beginning of 1942, employment at Chatuge dropped sharply to below 500 workers. Construction at the four Hiwassee projects (Apalachia, Ocoee, Chatuge, and Nottely) peaked at the same time at 8,700 total workers.²⁰

The project required the relocation of 278 families from the reservoir, all of whom were permanent residents of the county. Of these 278 families, 106 were farm owners, and fifty-two were farm tenants; the remainder were non-farming.²¹ The area of the proposed reservoir was largely agricultural and declared some of the best farmland in the area. Chief crops included corn, hay, and tobacco. There were also several large dairy operations, as well as cattle, hog, and sheep farms; however, the construction of Chatuge did bring much needed jobs to the area resulting in 1,521,831 man hours of labor. The Chatuge project also resulted in the removal or relocation of schools, churches, and forty miles of roadway.

The Chatuge project required the acquisition of 11,462 acres of land - 6,048 acres in Clay County, North Carolina, and 5,414 acres in Towns County, Georgia. Nearly eighty-eight percent of the total land acquired was done so by voluntary transfer, while the other twelve percent was condemned.²² The project also required the relocation of twenty cemeteries with 2,199 graves.²³ TVA surveyed and mapped all cemeteries within the reservoir. Mapping used a symbol system to convey data such as location, condition, and type of marker. Individual records plats were made for affected cemeteries, as well as reinternment cemeteries.

After World War II, the two planned recreational facilities were finally completed east of the spillway and west of the dam embankment. The west recreational area included a campground, boat launch ramp, toilet building, and beach area. The east recreational area included a picnic area and boat launch ramp.

Since their construction, the powerhouse, intake, and spillway have not been significantly altered and retain their original exterior design and detailing. The interior of the powerhouse has undergone some minimal upgrades including linoleum flooring in the control room and plumbing fixtures in the rest room.

¹⁸ Tennessee Valley Authority, "The Hiwassee Valley Projects," (Knoxville: Tennessee Valley Authority, 1948), 626.

¹⁹ Tennessee Valley Authority, "Mechanical Design of Hydro Plants," 281.

²⁰ Tennessee Valley Authority, "The Hiwassee Valley Projects," 332-33.

²¹ Tennessee Valley Authority, "The Hiwassee Valley Projects," 528.

²² Ibid, 521.

²³ Ibid, 552.

Chatuge Hydroelectric Project
Name of Property

Clay, NC
County and State

SIGNIFICANCE IN ENGINEERING

The Chatuge Hydroelectric Project is an integral part of the overall engineering design of the TVA system. Located on the Hiwassee River, the Chatuge dam's release provides power to the Hiwassee Hydroelectric Project downstream. The Chatuge project was initially planned and constructed for flood control and as a storage dam without power-generating equipment. The purpose of this storage dam was to provide stream flow regulation and additional power downstream to the TVA system. The initial project included a rolled earth-fill dam, flashboard chute spillway, a valve house, and an intake tower with a steel penstock and Howell-Bunger valve.²⁴

In terms of site preparation, the group of Hiwassee projects required the usual amount of detailed engineering investigation and planning as all other TVA projects; however, due to the immediate need for construction, site preparation and analysis was completed as soon as the TVA Board of Directors authorized the project. Surveying and mapping included basic control surveys, aerial photography of 424 square miles, land ownership reconnaissance surveys through planimetric-base plane table sheets and deed copying of 52,521 acres, marking and mapping contours of 615 miles, planning and mapping relocation of roads, rail lines, and utility lines, drainage surveys for malaria control, and numerous other adjustments and computations as the work progressed.²⁵

Upon initial construction of the rolled earth-fill dam, a twenty-six-foot wide and sixteen-foot, seven-inch high concrete culvert was constructed along the right bank of the Hiwassee River to divert water from the channel away from the construction site. Upon closure of the dam on February 12, 1942, an intake tower was constructed at the entrance of the culvert, which was lined with a steel trashrack and served as the start point of a penstock. Once the dam was closed, a twelve-foot diameter, steel penstock running the entire width of the dam was installed inside the culvert and has Howell-Bunger valve at the outlet. The purpose of the penstock, or conduit, and the valve was to control discharge from the reservoir to the Hiwassee River below.²⁶ This control of discharge allowed for water to be removed from the reservoir without power generation. At the time of construction by 1942, the installation of power-generating equipment was not considered economical for the project.

By 1952, TVA deemed the installation of a single generator unit at Chatuge cost effective as a mean of providing a minimum continuous flow of water to the Hiwassee River. Construction of a powerhouse in place of the valve house, a single generator turbine, and switchyard with transmission lines began on August 14, 1952.²⁷ A small, reinforced-concrete powerhouse was constructed with an outdoor deck for the single generator unit and sluice gate below. The powerhouse was designed with limited fenestration and an exterior of board-formed, poured concrete.

²⁴ Tennessee Valley Authority, "Mechanical Design of Hydro Plants," (Knoxville: Tennessee Valley Authority, 1960), 281.

²⁵ Ibid, 506.

²⁶ Ibid.

²⁷ Ibid, 284.

Chatuge Hydroelectric Project
Name of Property

Clay, NC
County and State

The hydraulic turbine installed was manufactured by James Leffel and Company, and the generator, by Westinghouse Electric Corporation. The turbine type is Francis, which is a type of turbine used to extract energy from the turbine blades as working fluid enters the turbine under extreme pressure. It has a rated capacity of 13,800 horsepower at 100-foot net head. It has a rated speed of 180 revolutions per minute and a maximum runaway speed of 334 revolutions per minute. The generator type is enclosed with a vertical shaft cooled by forced-air circulation through six water-cooled heat exchangers. It has a rated capacity of 11,111 kVA, 10,000 kW. It has continuous output at 0.9 pf, 6,900 volts, 3-phase, 60 cycles.²⁸

The governor cabinet for the generator and turbine is a single cabinet-actuator type manufactured by Woodward Governor Company. The cabinet contains a governor head, sump tank, pressure tank, oil pumps, magnet generator, and auxiliary controls. There are also two herringbone type gears for oil pressure. Each pump has a capacity of seventy-five gallons per minute with pressure rated at 300 pounds per square inch and driven by a twenty-horsepower motor.

SIGNIFICANCE IN RECREATION

Following World War II, as middle class American households gained wealth and indoor electricity, a by-product was outdoor leisure time. The TVA's contribution to recreational activities is noteworthy. The agency's hydroelectric projects' reservoirs attract outdoor enthusiasts who enjoy fishing, boating, camping, and hiking in the environs the TVA helped create, re-forest, and conserve. The agency operates some 100 public recreation areas throughout the TVA region.

Recreational opportunities were investigated during the planning process for the Chatuge Hydroelectric Project. The mountainous terrain surrounding the Nantahala and Chattahoochee National Forests provided hundreds of miles of accessible shoreline for recreational development. The TVA plans identified five access points on the reservoir with highway access. Plans included a small overlook point, picnic areas, boat launching ramps, and fishing camps to serve both tourists and local residents.

The TVA provided recreational opportunities at most of its hydroelectric projects. At Chatuge there is a picnic area just to the east of the spillway which has picnic tables and a boat ramp. West of the dam is the Gibson Cove Campground developed by TVA and now leased to the City of Hayesville. The campground contains numerous campsites, picnic tables, and a bath house. There is also an access point for fishing on the Hiwassee River downstream from the powerhouse.

²⁸ Ibid, 285.

Chatuge Hydroelectric Project
Name of Property

Clay, NC
County and State

SUMMARY

The Chatuge Hydroelectric Project was one of twenty-five projects constructed by the Tennessee Valley Authority (TVA) for the purpose of generating electrical power from, improving navigation of, and controlling seasonal flooding of the river system of the region. The project brought construction jobs and later electricity to the rural area. During planning and construction, TVA provided technical assistance in municipal land use planning, road relocation and improvement, and shoreline development. The Chatuge facility is an important component in the vast TVA system of flood control and power generation.

The Chatuge Hydroelectric Project retains much of its integrity from its original design of the early 1940s and later expansion in the 1950s. The dam and powerhouse have not been significantly altered and display their original design. The project continues to be an integral part of the TVA system. The Chatuge Hydroelectric Project meets the registration requirements set forth in the Multiple Property Documentation Form, "Historical Resources of the Tennessee Valley Authority Hydroelectric Project, 1933-1979" and this MPDF contains additional contextual information concerning TVA and its hydroelectric system.

Chatuge Hydroelectric Project
Name of Property

Clay, NC
County and State

9. Major Bibliographical References

Bibliography (Cite the books, articles, and other sources used in preparing this form.)

oA History of Clay County.ö At webpage

http://www.carolana.com/NC/Counties/clay_county_nc.html accessed August 11, 2015.

oChatuge Dam.ö At webpage

<http://www.ncmtchamber.com/images/stories/pdfs/permanent/history/Electric-Dam-2pgs.pdf>. Accessed August 5, 2015.

oChatuge Reservoir,ö at webpage <http://www.tva.gov/sites/chatuge.htm>. Accessed August 4, 2015.

oEconomic Development.ö At webpage <http://www.tva.com/econdev/index.htm>. Accessed May 5, 2015.

Ezzell, Patricia Bernard.öTennessee Valley Authority in Alabama (TVA),ö available at webpage <http://www.encyclopediaofalabama.org/article/h-2380>, accessed April 22, 2015.

oHistory of Lake Chatuge.ö At webpage

<http://www.greatgeorgiaproPERTIES.com/Outdoor-adventures/Lake-Chatuge-History.htm>. Accessed August 5, 2015.

oHistory of Lake Chatuge.ö At webpage

<http://historicalhayesville.blogspot.com/2011/12/history-of-lake-chatuge.html>. Accessed August 5, 2015.

oHistory of the Tennessee Valley Authority.ö At webpage

http://www.policyalmanac.org/economic/archive/tva_history.shtml. Accessed August 5, 2015.

Sawyer, Gordon. *Northeast Georgia: A History*. Charleston, SC: Arcadia Publishing, 2001

Tennessee Valley Authority Act of 1933, at website

http://www.policyalmanac.org/economic/archive/tva_history.shtml. Accessed April 16, 2015.

Tennessee Valley Authority. *Design of TVA Projects Technical Report No. 24, Vol. 1, Civil and Structural Design*. Washington, D.C.: U.S. Government Printing Office, 1952.

Tennessee Valley Authority. *Design of TVA Projects Technical Report No. 24, Vol. 3, Mechanical Design of Hydro Plants*. Washington, D.C.: U.S. Government Printing Office, 1960

Chatuge Hydroelectric Project
Name of Property

Clay, NC
County and State

Tennessee Valley Authority. *The Hiwassee Valley Projects Technical Report No. 5, Vol. 2, The Appalachia, Ocoee No. 3, Nottely, and Chatuge Projects*. Washington, D.C.: U.S. Government Printing Office, 1948

Wheeler, W. Bruce. "Tennessee Valley Authority." At webpage Tennessee Encyclopedia of History and Culture. Accessed May 29, 2015.

Previous documentation on file (NPS):

- preliminary determination of individual listing (36 CFR 67) has been requested
- previously listed in the National Register
- previously determined eligible by the National Register
- designated a National Historic Landmark
- recorded by Historic American Buildings Survey # _____
- recorded by Historic American Engineering Record # _____
- recorded by Historic American Landscape Survey # _____

Primary location of additional data:

- State Historic Preservation Office
 - Other State agency
 - Federal agency
 - Local government
 - University
 - Other
- Name of repository: Tennessee Valley Authority, Knoxville, Tennessee

Historic Resources Survey Number (if assigned): CY0025

Chatuge Hydroelectric Project
Name of Property

Clay, NC
County and State

10. Geographical Data

Acreage of Property 508 acres

Use either the UTM system or latitude/longitude coordinates

Latitude/Longitude Coordinates (decimal degrees)

Datum if other than WGS84: _____

(enter coordinates to 6 decimal places)

- | | |
|--------------|------------|
| 1. Latitude: | Longitude: |
| 2. Latitude: | Longitude: |
| 3. Latitude: | Longitude: |
| 4. Latitude: | Longitude: |

Or

UTM References

Datum (indicated on USGS map):

NAD 1927 or NAD 1983

- | | | |
|-------------|------------------|-------------------|
| 1. Zone: 17 | Easting: 2444390 | Northing: 3877741 |
| 2. Zone: 17 | Easting: 244862 | Northing: 3877786 |
| 3. Zone: 17 | Easting: 245700 | Northing: 3880138 |
| 4. Zone: 17 | Easting: 247040 | Northing: 3879294 |

Verbal Boundary Description (Describe the boundaries of the property.)

The boundary for the Chatuge Hydroelectric Project is depicted as a dashed line on the accompanying US Quad map and TVA site plan map. The boundary includes property to encompass the adjacent recreational facilities as well as the immediate environs of the dam and powerhouse.

Boundary Justification (Explain why the boundaries were selected.)

The boundary includes all facilities necessary for the operation of the hydroelectric project and/or associated with the mission of TVA, which includes power generation, navigation, and public recreation. The boundary omits other TVA lands not directly associated with hydroelectric production

Chatuge Hydroelectric Project
Name of Property

Clay, NC
County and State

HAYESVILLE, TN, UGSS Topo Revision 2014

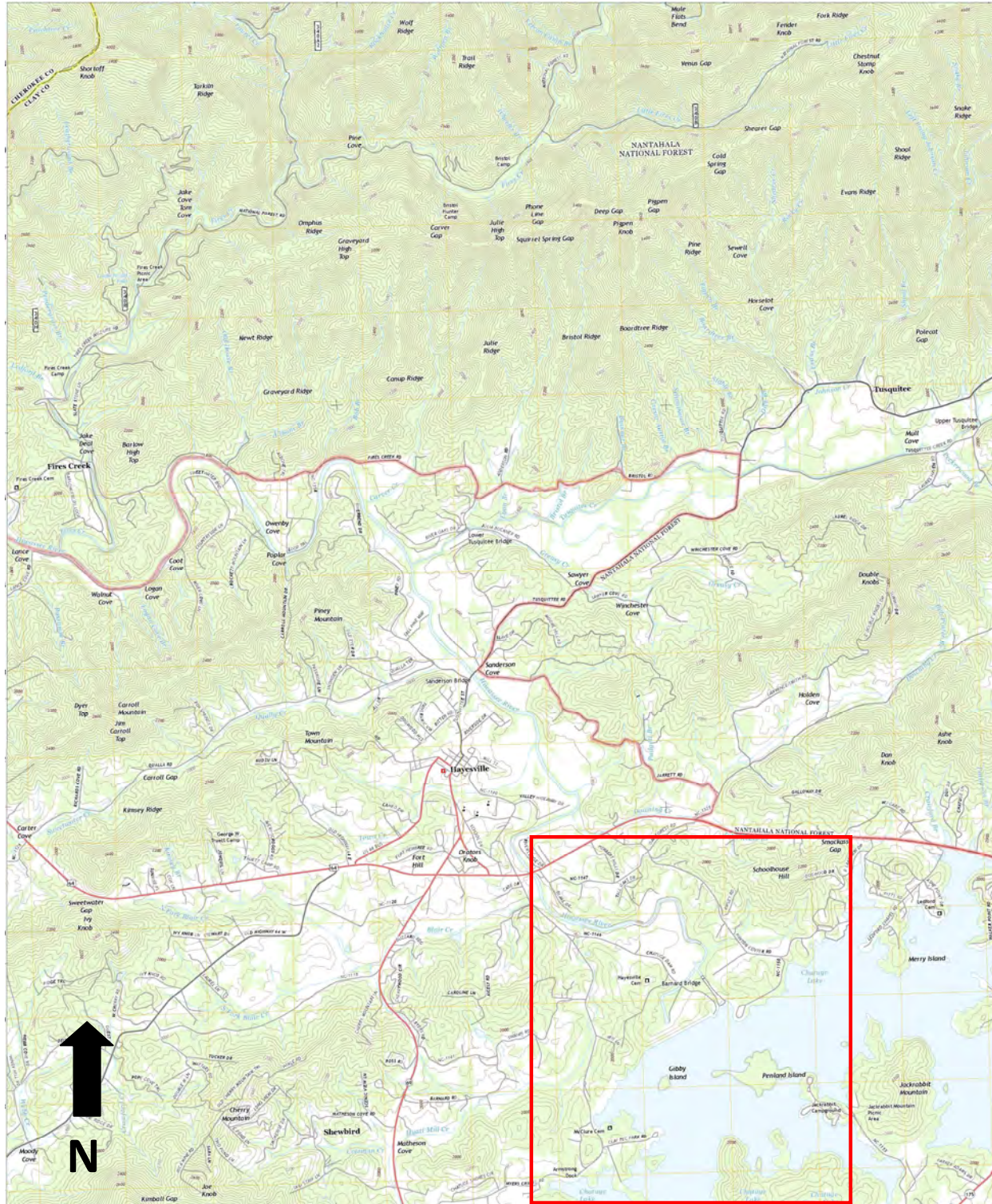

Chatuge Hydroelectric Project
Name of Property

Clay, NC
County and State

Enlarged section depicting Chatuge Dam and Reservoir from 2013 Hayesville Quad

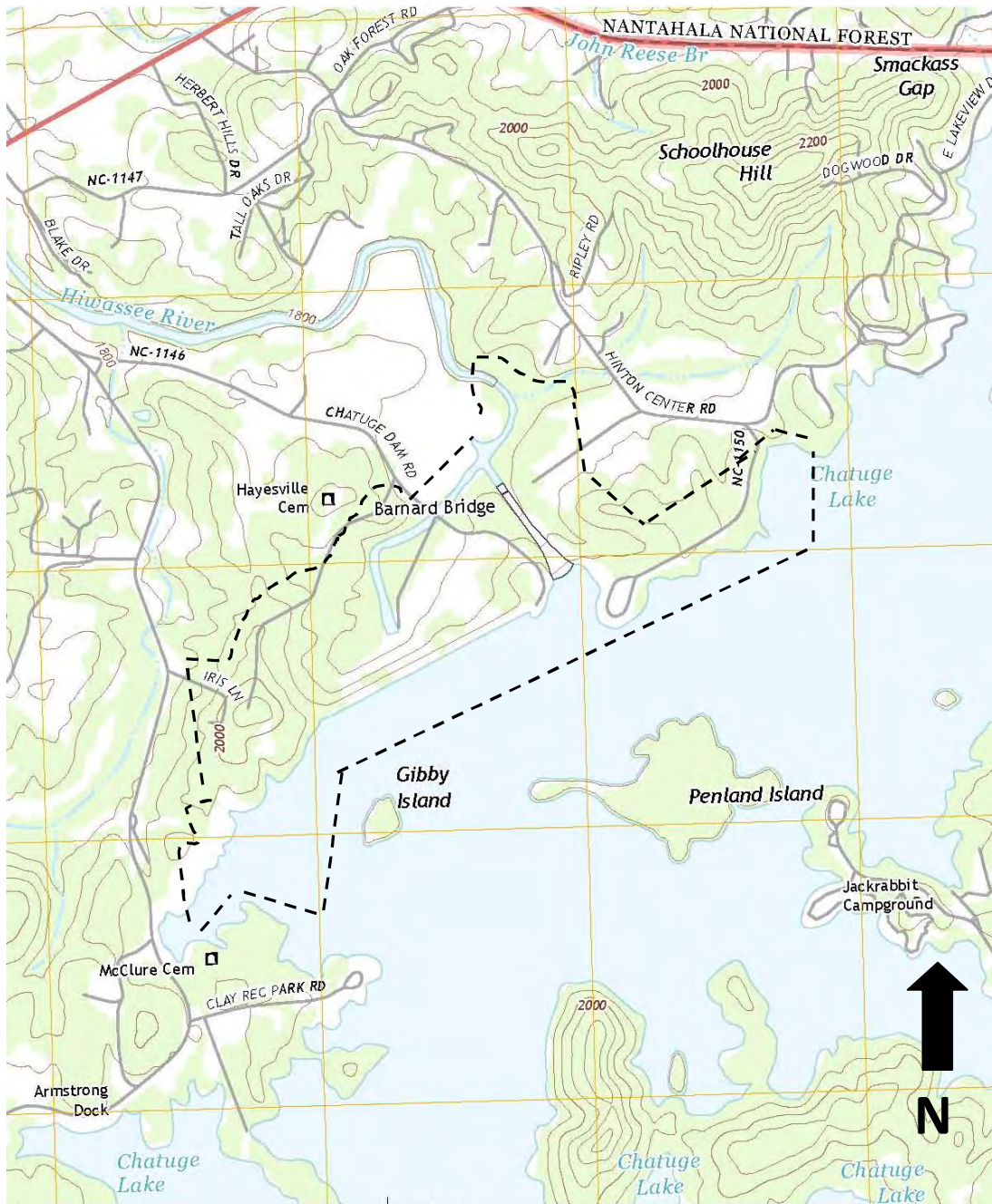

SCALE 1:24 000

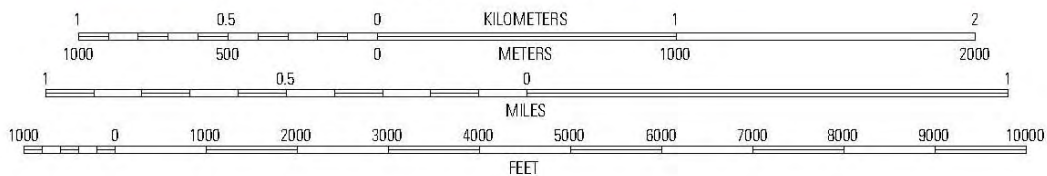

Chatuge Hydroelectric Project
Name of Property

Clay, NC
County and State

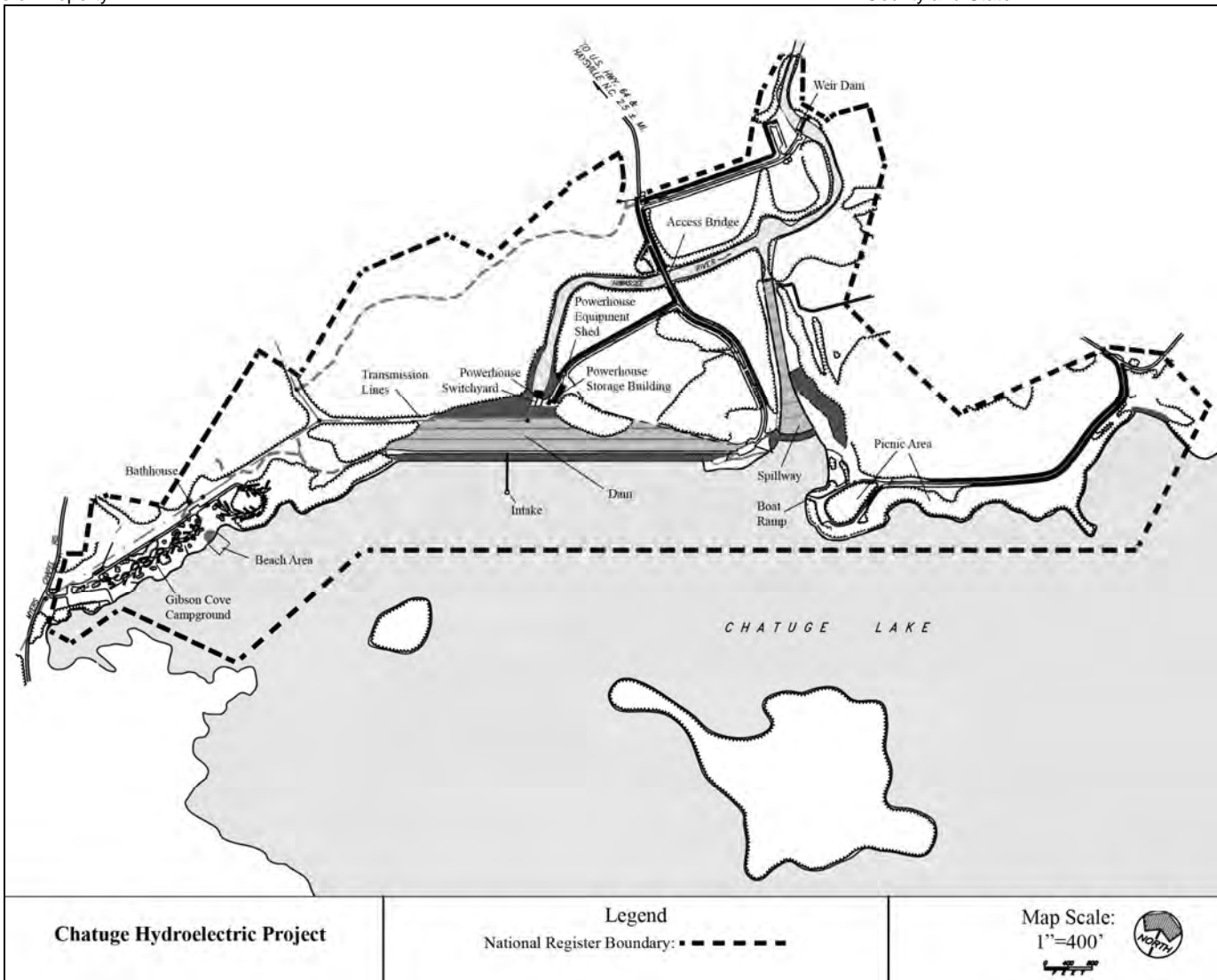

Site plan and National Register boundary for Chatuge Hydroelectric Project.

Chatuge Hydroelectric Project
Name of Property

Clay, NC
County and State

11. Form Prepared By

name/title: Rebecca Hightower/Philip Thomason/Andra Kowalczyk Martens
organization: Thomason and Associates
street & number: P.O. Box 121225
city or town: Nashville state: TN zip code: 37212
e-mail thomason@bellsouth.net
telephone: 615-385-4960
date: April 22, 2016

Additional Documentation

Submit the following items with the completed form:

- **Maps:** A **USGS map** or equivalent (7.5 or 15 minute series) indicating the property's location.
- **Sketch map** for historic districts and properties having large acreage or numerous resources. Key all photographs to this map.
- **Additional items:** (Check with the SHPO, TPO, or FPO for any additional items.)

Chatuge Hydroelectric Project
Name of Property

Clay, NC
County and State

Photographs

Submit clear and descriptive photographs. The size of each image must be 1600x1200 pixels (minimum), 3000x2000 preferred, at 300 ppi (pixels per inch) or larger. Key all photographs to the sketch map. Each photograph must be numbered and that number must correspond to the photograph number on the photo log. For simplicity, the name of the photographer, photo date, etc. may be listed once on the photograph log and doesn't need to be labeled on every photograph.

Photo Log

Name of Property: Chatuge Hydroelectric Project

City or Vicinity: Hayesville

County: Clay

State: North Carolina

Photographer: Thomason and Associates

Date Photographed: July 14, 2015

Description of Photograph(s) and number, include description of view indicating direction of camera:

- 1 of 30 - General View of Chatuge Dam, looking northeast
- 2 of 30 - North side of Chatuge Dam, looking southwest
- 3 of 30 ó Across top of Chatuge Dam, looking west.
- 4 of 30 ó Across top of Chatuge Dam, looking east
- 5 of 30 ó Spillway, looking east.
- 6 of 30 - Top of Spillway, looking west.
- 7 of 30 - Spillway lanes, looking northwest.
- 8 of 30 - Powerhouse exterior, west elevation, looking east.
- 9 of 30 - Powerhouse exterior, northwest elevation, looking southeast.
- 10 of 30 - Powerhouse exterior, east elevation, looking west.
- 11 of 30 - Powerhouse exterior, northeast elevation, looking southwest.
- 12 of 30 - Powerhouse interior, control room.
- 13 of 30 - Powerhouse interior, basement control area.

Chatuge Hydroelectric Project
Name of Property

Clay, NC
County and State

- 14 of 30 - Powerhouse interior, generator wheel pit access.
- 15 of 30 - Powerhouse interior, control and pipe gallery at turbine.
- 16 of 30 - Powerhouse Storage Building exterior southwest elevation, looking northeast.
- 17 of 30 - Powerhouse Storage Building exterior northeast elevation, looking southwest.
- 18 of 30 - Powerhouse Equipment Shed exterior west elevation, looking northeast.
- 19 of 30 - Intake and steel footbridge, looking east.
- 20 of 30 - Intake, looking east.
- 21 of 30 - Switchyard, looking southeast.
- 22 of 30 - Switchyard and Transmission lines, looking southwest.
- 23 of 30 - Weir Dam, looking east.
- 24 of 30 - Weir Dam pedestrian landing, looking northeast.
- 25 of 30 - Picnic Area, looking northwest.
- 26 of 30 - Boat Ramp at picnic area, looking west.
- 27 of 30 - Campground, looking southwest.
- 28 of 30 - Bathhouse at campground south elevation, looking north.
- 29 of 30 - Hiwassee River Bridge, looking south
- 30 of 30 - Hiwassee River Bridge, pier looking west.

Chatuge Hydroelectric Project
Name of Property

Clay, NC
County and State

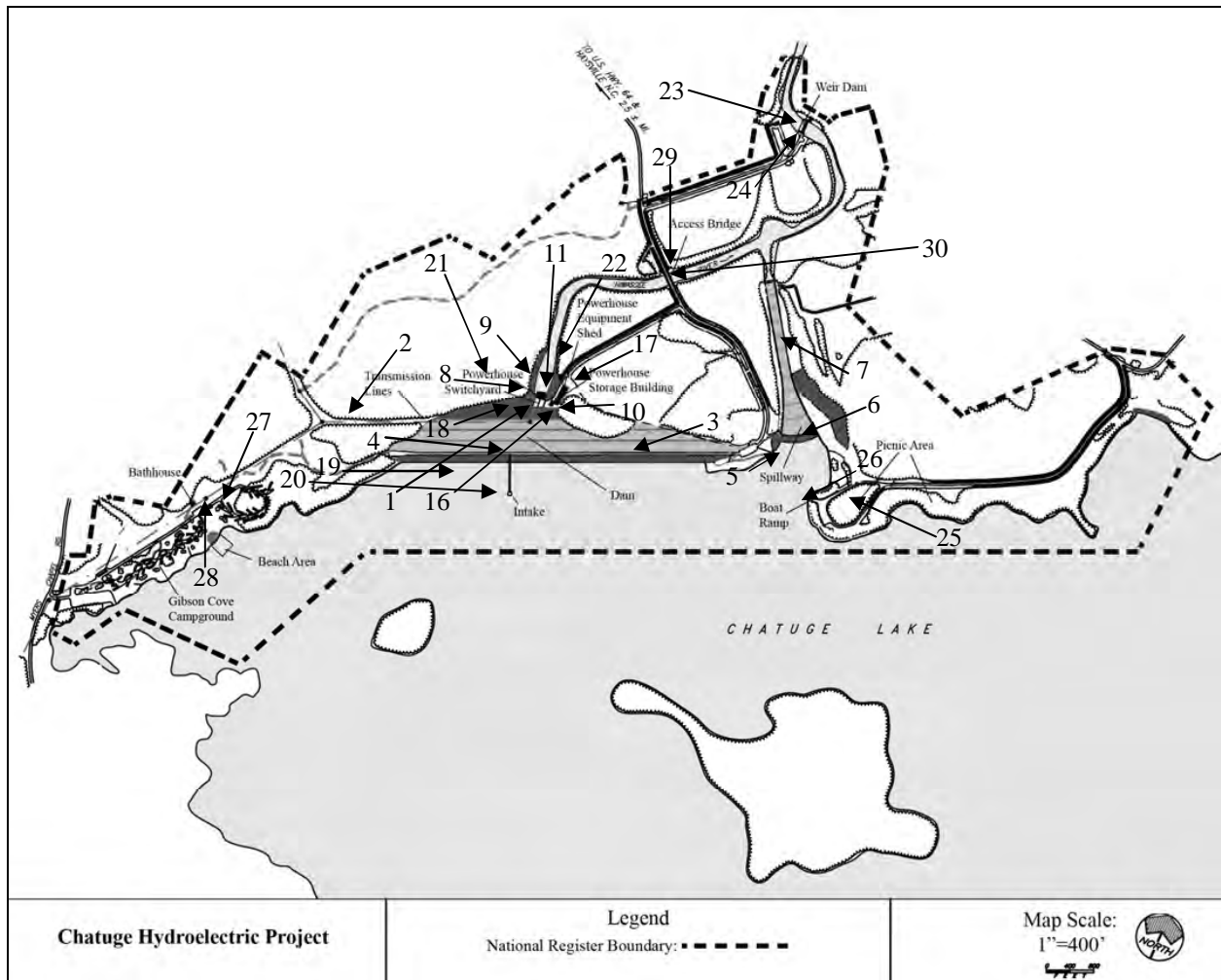

(Powerhouse interior photos, #12-15)

Photo key map for Chatuge (not to scale)

Chatuge Hydroelectric Project
Name of Property

Clay, NC
County and State

Site Plans

Site plan of Chatuge Hydroelectric Project

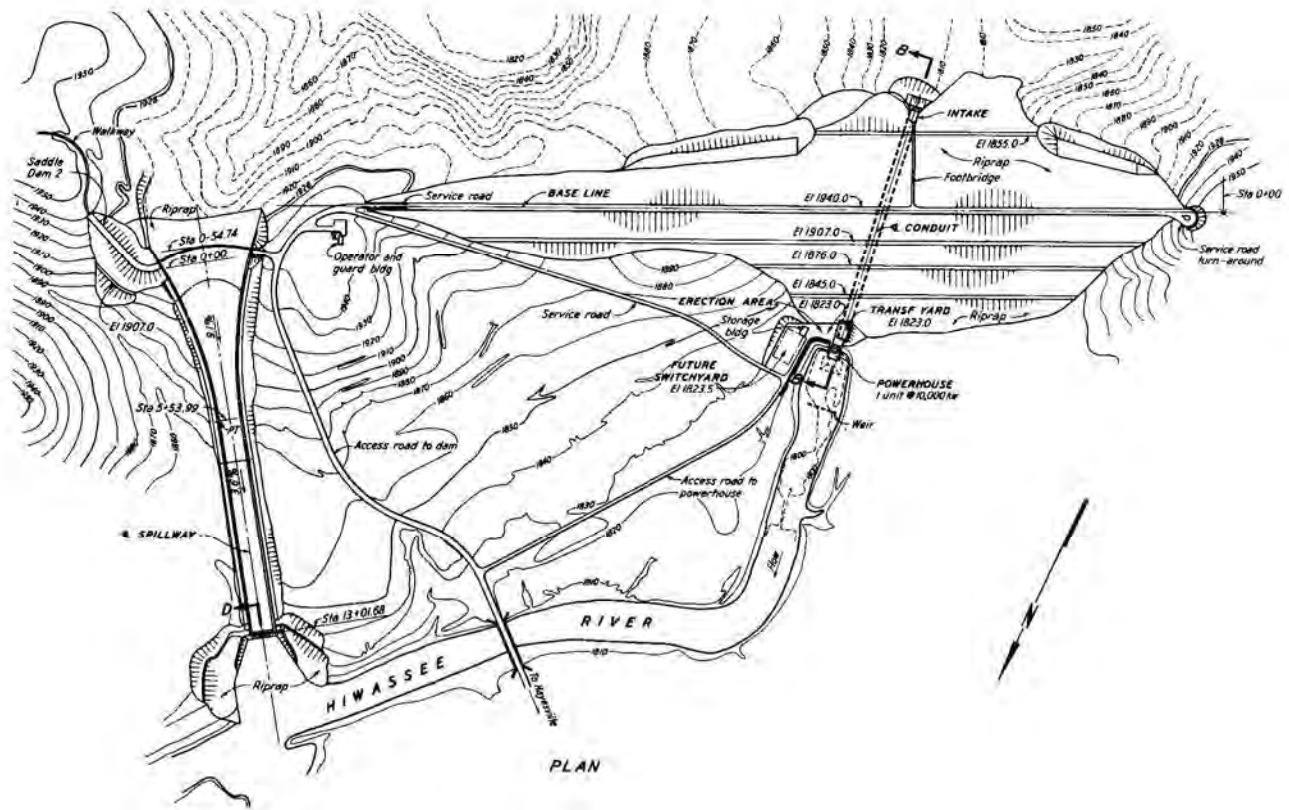

Chatuge Hydroelectric Project
 Name of Property

Clay, NC
 County and State

Elevation and Sections

Intake, Dam and Powerhouse Section

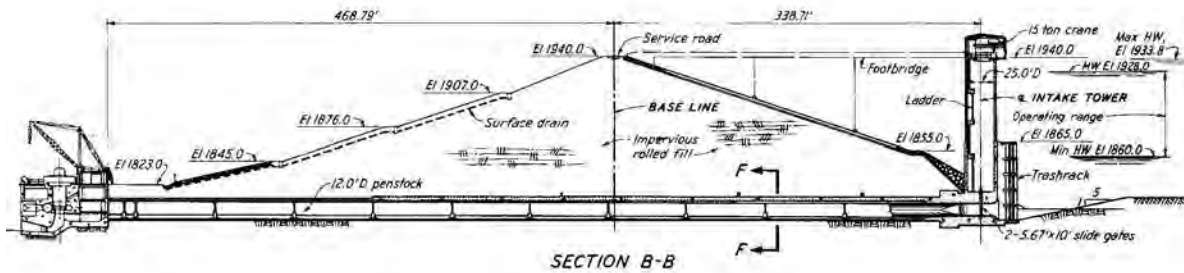

Powerhouse and Turbine Section

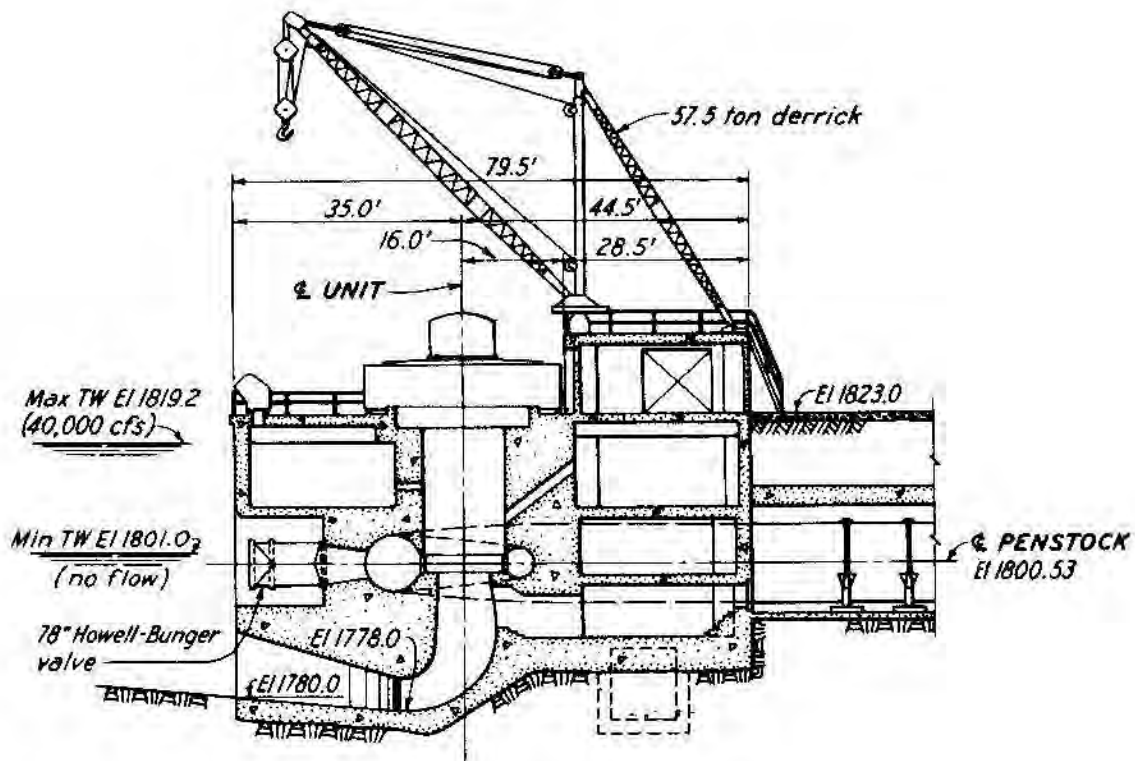

SECTION - POWERHOUSE

Chatuge Hydroelectric Project
 Name of Property

Clay, NC
 County and State

Chatuge Inake Outlet plan and section

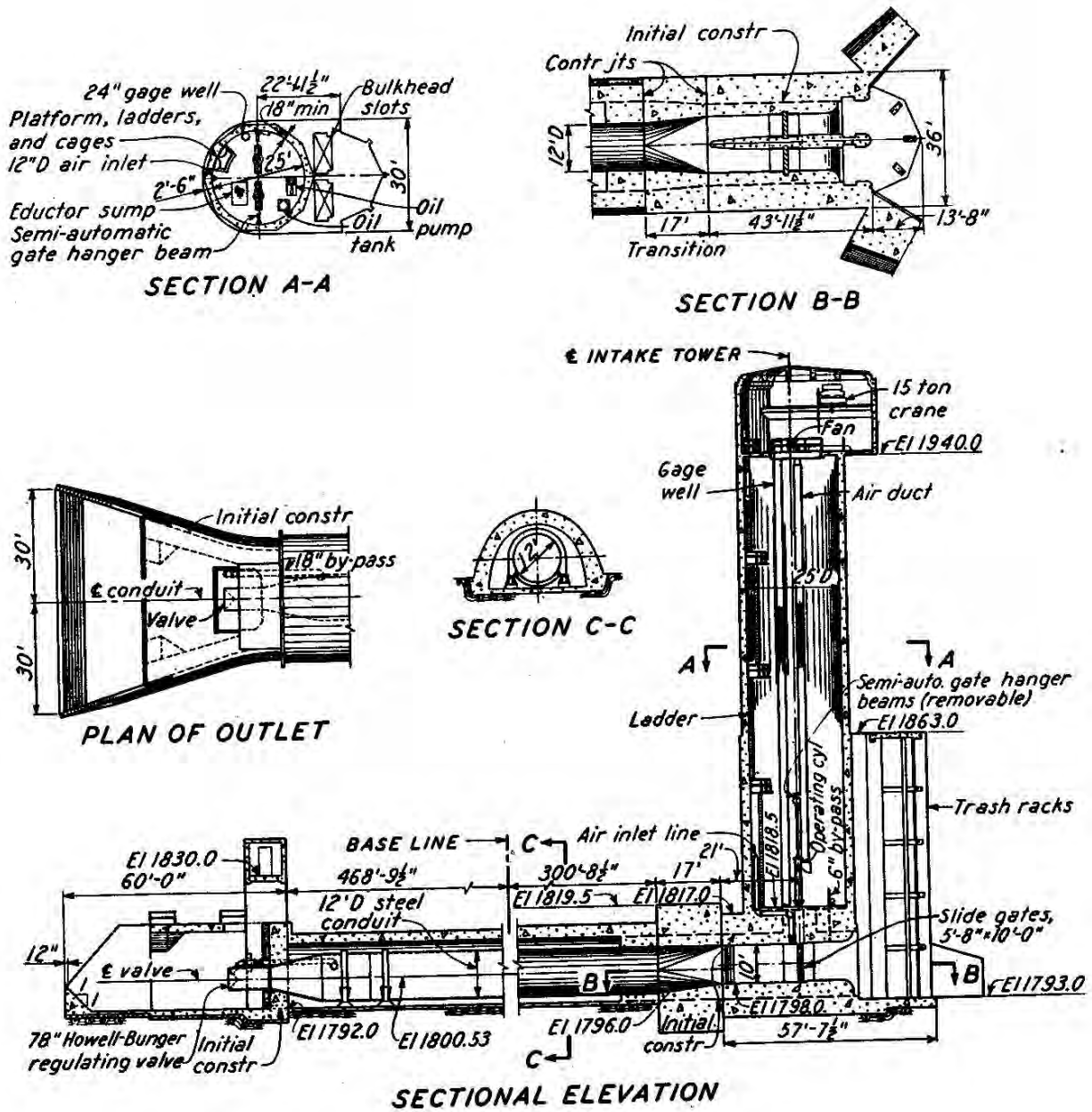

Chatuge Hydroelectric Project
 Name of Property

Clay, NC
 County and State

Chatuge Spillway plan and section

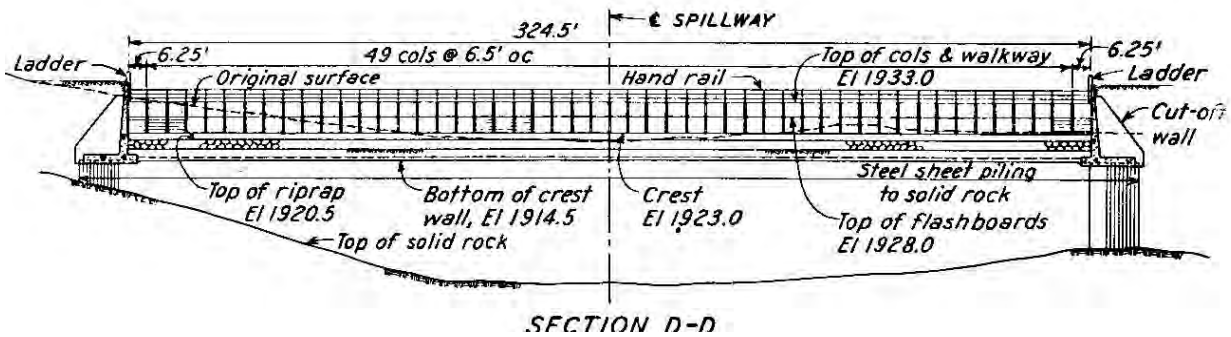
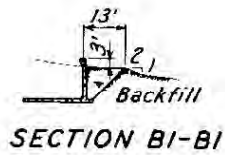
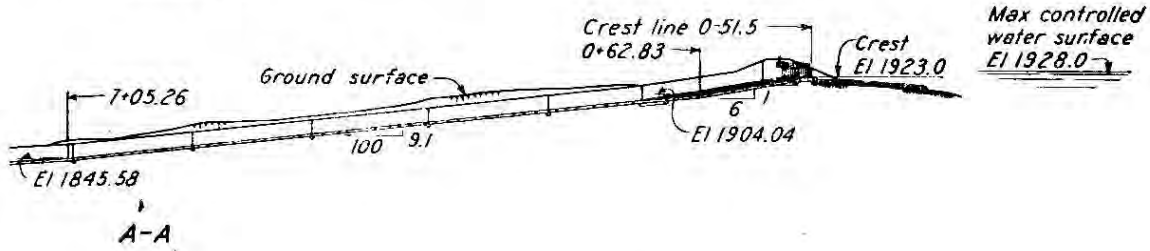
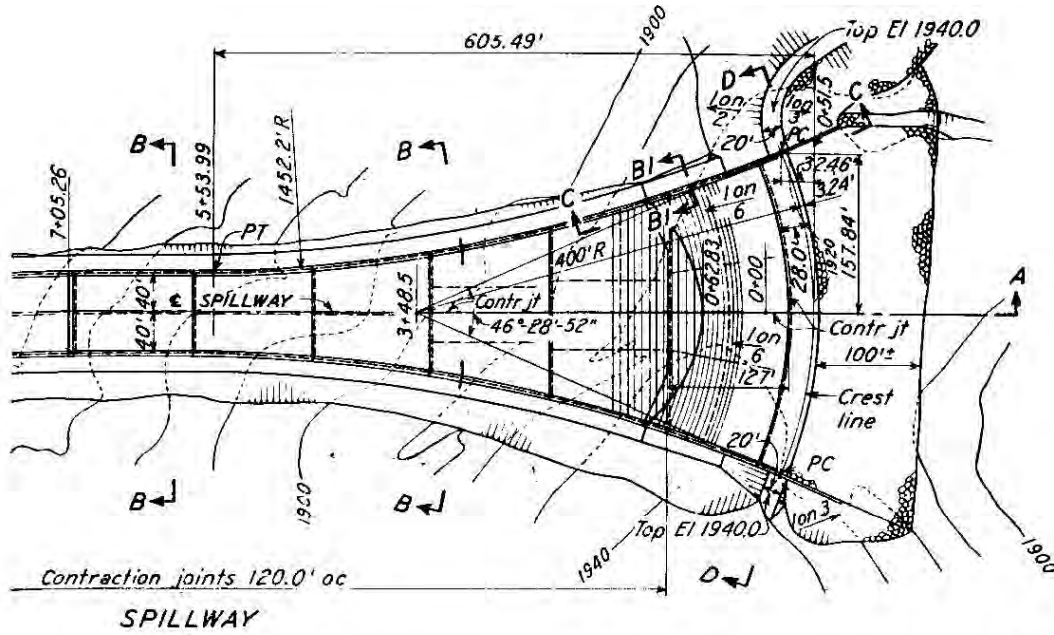

Chatuge Hydroelectric Project
Name of Property

Clay, NC
County and State

Howell-Bunger Valve- Intake (used at Nottely and Chatuge)

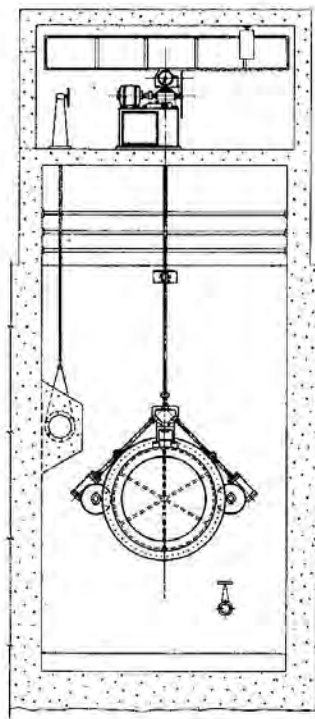
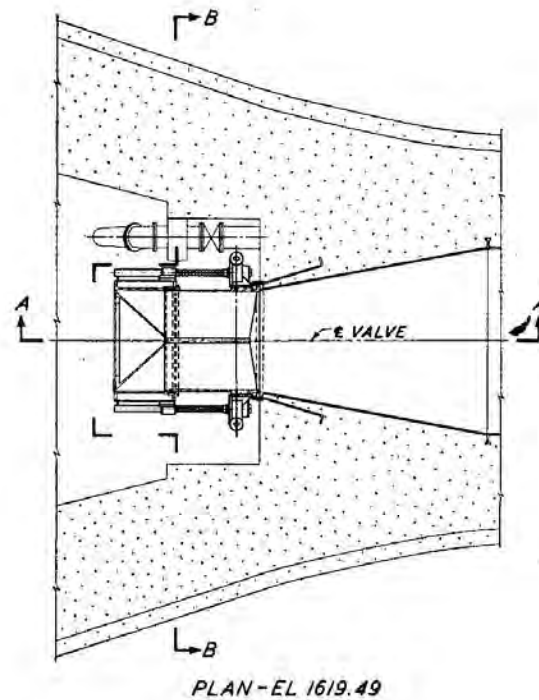

SECTION B - B

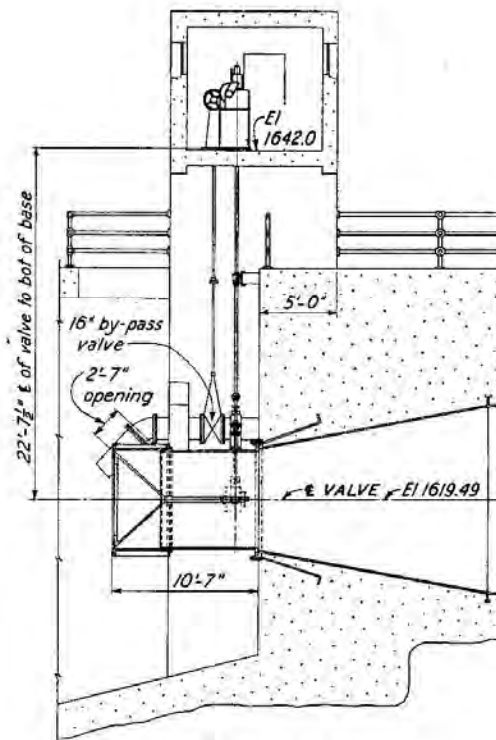

SECTION A - A

FIGURE 124.—Howell-Bunger valve at Nottely.

Chatuge Hydroelectric Project
Name of Property

Clay, NC
County and State

Property Owner:

(This information will not be submitted to the National Park Service, but will remain on file at the Tennessee Historical Commission)

Name Tennessee Valley Authority ó Pat Ezzell

Street &
Number 400 West Summit Hill Drive 460WT7D-K Telephone 865-632-6461

City or
Town Knoxville State/Zip TN 37902

Paperwork Reduction Act Statement: This information is being collected for applications to the National Register of Historic Places to nominate properties for listing or determine eligibility for listing, to list properties, and to amend existing listings. Response to this request is required to obtain a benefit in accordance with the National Historic Preservation Act, as amended (16 U.S.C.460 et seq.).

Estimated Burden Statement: Public reporting burden for this form is estimated to average 100 hours per response including time for reviewing instructions, gathering and maintaining data, and completing and reviewing the form. Direct comments regarding this burden estimate or any aspect of this form to the Office of Planning and Performance Management, U.S. Dept. of the Interior, 1849 C. Street, NW, Washington, DC.





















NOTICE
NO PARKING
OR STOPPING
IN THIS AREA
EXCEPT AS
AUTHORIZED BY
A SIGN

DANGER
ELECTRICITY

LIMITED
ACCESS







CAUTION
WEARING PROTECTION
REQUIRED IN THIS AREA
IF EXPOSURE EXCEEDS
4 HOURS PER DAY

CAUTION
DO NOT
REACH INTO
THIS AREA

New Safety



A safety poster is mounted on the right wall. It features the title "New Safety" at the top. Below the title, there is a photograph of a person in a blue uniform working in an industrial setting. At the bottom of the poster, there is a smaller photograph of a family consisting of a man, a woman, and two children.







Storage Unit









CHATUCE





NOTICE
This is a restricted area.
No unauthorized persons
are allowed to enter.
If you see a sign, you
are in a restricted area.
If you see a sign, you
are in a restricted area.

WARNING
ELECTRICITY
DANGER

















COUNTY COMMISSIONERS
W J WINCHESTER
W B LOWE
J A WOOD
BUILT BY
WY MOORE CONCRETE PRODUCTION
ANDREWS NC
1922

UNITED STATES DEPARTMENT OF THE INTERIOR
NATIONAL PARK SERVICE

NATIONAL REGISTER OF HISTORIC PLACES
EVALUATION/RETURN SHEET

Requested Action:

Property Name:

Multiple Name:

State & County:

Date Received: 6/30/2017 Date of Pending List: 7/27/2017 Date of 16th Day: 8/11/2017 Date of 45th Day: 8/14/2017 Date of Weekly List:

Reference number:

Nominator:

Reason For Review:

- | | | |
|---------------------------------------|--|---|
| <input type="checkbox"/> Appeal | <input type="checkbox"/> PDIL | <input type="checkbox"/> Text/Data Issue |
| <input type="checkbox"/> SHPO Request | <input type="checkbox"/> Landscape | <input type="checkbox"/> Photo |
| <input type="checkbox"/> Waiver | <input checked="" type="checkbox"/> National | <input type="checkbox"/> Map/Boundary |
| <input type="checkbox"/> Resubmission | <input type="checkbox"/> Mobile Resource | <input type="checkbox"/> Period |
| <input type="checkbox"/> Other | <input type="checkbox"/> TCP | <input type="checkbox"/> Less than 50 years |
| | <input type="checkbox"/> CLG | |

Accept Return Reject 8/11/2017 Date

Abstract/Summary Comments:

Recommendation/ Criteria:

Reviewer Jim Gabbert Discipline Historian

Telephone (202)354-2275 Date _____

DOCUMENTATION: see attached comments : No see attached SLR : **Yes**

If a nomination is returned to the nomination authority, the nomination is no longer under consideration by the National Park Service.



June 21, 2017

Paul Loether
National Register of Historic Places, Keeper
Mail Stop 7228
1849 C Street NW
Washington, D. C. 20240

Dear Mr. Loether,

The Tennessee Valley Authority (TVA) contracted with Thomason and Associates, Preservation Planners to complete nominations to the National Register of Historic Places (NRHP) for twenty-five of its hydroelectric projects. Three nominations - for the Norris, Guntersville, and Wheeler Hydroelectric Projects - were previously submitted, resulting in listing in the NRHP in 2016. The TVA proposes the nomination of the remaining twenty-two hydroelectric projects. The enclosed disks contain the true and correct copies of the nominations of:

Georgia: the Nottely Hydroelectric Project;
Kentucky: the Kentucky Hydroelectric Project;
North Carolina: the Apalachia, Chatuge, Fontana, and Hiwassee Hydroelectric Projects; and
Tennessee: the Boone, Cherokee, Chickamauga, Douglas, Fort Loudoun, Fort Patrick Henry, Melton Hill, Nickajack, Normandy, Ocoee No. 3, Pickwick Landing, South Holston, Tellico, Tims Ford, Watts Bar, and Watauga Hydroelectric Projects.

The overall context for these nominations, the MPDF "Historic Resources of the Tennessee Valley Authority Hydroelectric System, 1933-1979" was approved by your office on March 12, 2016. The enclosed nominations have been reviewed by TVA as well as the respective State Review Boards and enclosed are the twenty-two physical signed copies of the signature pages of each nomination. All local governments have been notified of the intent to list these hydroelectric projects in the National Register.

We are pleased to submit these nominations to you which recognize the diverse history and contributions made by the Tennessee Valley Authority to our nation.

Please contact me if any additional information is needed.

Sincerely,

A handwritten signature in black ink that reads "Philip Thomason".

Philip Thomason
Principal

cc. Pat Ezell, Senior Program Manager, TVA

Enc/



Tennessee Valley Authority, 400 West Summit Hill Drive, Knoxville, TN 37902

August 9, 2017

Mr. Paul Loether
National Register of Historic Places, Keeper
Mail Stop 7228
1849 C Street NW
Washington, D. C. 20240

Dear Mr. Loether,

The Tennessee Valley Authority (TVA) contracted with Thomason and Associates, Preservation Planners to complete nominations to the National Register of Historic Places (NRHP) for twenty-five of its hydroelectric projects. Three nominations for the Norris, Guntersville, and Wheeler Hydroelectric Projects were previously submitted resulting in listing in the NRHP in 2016. The TVA proposes the nomination of the remaining twenty-two hydroelectric projects. The enclosed disks contain the true and correct copies of the nominations of:

- Georgia: the Nottely Hydroelectric Project;
- Kentucky: the Kentucky Hydroelectric Project;
- North Carolina: the Apalachia, Chatuge, Fontana, and Hiwassee Hydroelectric Projects; and
- Tennessee: the Boone, Cherokee, Chickamauga, Douglas, Fort Loudoun, Fort Patrick Henry, Melton Hill, Nickajack, Normandy, Ocoee No. 3, Pickwick Landing, South Holston, Tellico, Tims Ford, Watts Bar, and Watauga Hydroelectric Projects.

The overall context for these nominations, the MPDF "Historic Resources of the Tennessee Valley Authority Hydroelectric System, 1933-1979" was approved by your office on March 12, 2016. The enclosed nominations have been reviewed by TVA as well as the respective State Review Boards and enclosed are the twenty-two physical signed copies of the signature pages of each nomination. All local governments have been notified of the intent to list these hydroelectric projects in the National Register.

We are pleased to submit these nominations to you which recognize the diverse history and contributions made by the Tennessee Valley Authority to our nation.

Please contact me if any additional information is needed.

Sincerely,

A handwritten signature in cursive script that reads "Pat Bernard Ezzell".

Patricia Bernard Ezzell
Federal Preservation Officer
Communications

Enclosures