

900

United States Department of the Interior  
National Park Service

# National Register of Historic Places Registration Form

This form is for use in nominating or requesting determinations of eligibility for individual properties or districts. See instructions in *Guidelines for Completing National Register Forms* (National Register Bulletin 16). Complete each item by marking "x" in the appropriate box or by entering the requested information. If an item does not apply to the property being documented, enter "N/A" for "not applicable." For functions, styles, materials, and areas of significance, enter only the categories and subcategories listed in the instructions. For additional space use continuation sheets (Form 10-900a). Type all entries.

### 1. Name of Property

historic name Riverton Inn, Yale's Hotel, Riverton Hotel, Old Ives Hotel, Ives Tavern  
other names/site number Old Riverton Inn (use for publication)

### 2. Location

street & number 436 East River Road NA  not for publication  
city, town Barkhamsted  vicinity Riverton  
state CT code CT county Litchfield code 005 zip code 06065

### 3. Classification

Ownership of Property	Category of Property	Number of Resources within Property	
<input checked="" type="checkbox"/> private	<input checked="" type="checkbox"/> building(s)	Contributing	Noncontributing
<input type="checkbox"/> public-local	<input type="checkbox"/> district	<u>1</u>	_____ buildings
<input type="checkbox"/> public-State	<input type="checkbox"/> site	_____	_____ sites
<input type="checkbox"/> public-Federal	<input type="checkbox"/> structure	_____	_____ structures
	<input type="checkbox"/> object	_____	_____ objects
		<u>1</u>	_____ Total

Name of related multiple property listing:  
NA

Number of contributing resources previously listed in the National Register NA

### 4. State/Federal Agency Certification

As the designated authority under the National Historic Preservation Act of 1966, as amended, I hereby certify that this  nomination  request for determination of eligibility meets the documentation standards for registering properties in the National Register of Historic Places and meets the procedural and professional requirements set forth in 36 CFR Part 60. In my opinion, the property  meets  does not meet the National Register criteria.  See continuation sheet.

Signature of certifying official

Date 6/17/92

State or Federal agency and bureau Director, Connecticut Historical Commission

In my opinion, the property  meets  does not meet the National Register criteria.  See continuation sheet.

Signature of commenting or other official

Date

State or Federal agency and bureau

### 5. National Park Service Certification

I, hereby, certify that this property is:

- entered in the National Register.
- See continuation sheet.
- determined eligible for the National Register.  See continuation sheet.
- determined not eligible for the National Register.

- removed from the National Register.
- other, (explain:)

Entered in the  
National Register

Arlene Byers

7/24/92

Signature of the Keeper

Date of Action

## 6. Function or Use

Historic Functions (enter categories from instructions)

DOMESTIC/hotel

Current Functions (enter categories from instructions)

DOMESTIC/hotel

## 7. Description

Architectural Classification

(enter categories from instructions)

EARLY REPUBLIC/Federal

Materials (enter categories from instructions)

foundation BRICK, STONE

walls WOOD/Weatherboard

roof ASPHALT

other

Describe present and historic physical appearance.

The Old Riverton Inn is a frame gable-roofed two-story structure with twin chimneys, facing west and overlooking a bridge across the the Farmington River. The bridge at this location, extant since the late 18th century, long was the only bridge across the river in the route of the Farmington River Turnpike as the turnpike wound its way from New Hartford north through Riverton to Colebrook and the Massachusetts state line. A connecting road also ran southwest to Winsted. The prominent intersection, which included the only opportunity to cross the river by bridge for many miles in either direction, brought heavy traffic that made made an attractive location for an inn.

Constructed at the turn of the 19th century, the building consists of a narrow 17' x 38' main block and a square 30' x 31' ell. In the five-bay front elevation the brick basement is exposed, giving the inn the appearance of a three-story building, while on the south side elevation there is a porch running back the depth of the ell. (Photograph 1) A historic photograph shows that the porch once ran across the front of the building as well. (Photograph 2)

The structure has grown over the years. Perhaps the original fabric is a one-story section at the rear of the ell. It has a fireplace with beehive oven, the only such fireplace on the premises<sup>1</sup>, suggesting considerable age. (Photograph 3) The main block is Federal in style, but the building has been altered and enlarged from time to time. The Italiante-style porch was added in mid 19th century, providing access to the front door, while a bay at basement level and additions to the north are mid-20th century work in the Colonial Revival style. These several sections are indicated on the ground plan and photograph key.

An event important to the inn structurally occurred as a consequence of the flood of 1938. The flood took out then-existing bridge across the Farmington River, in front of the inn. It was replaced in 1941 with a larger and stronger bridge. Construction of the new bridge required widening the road in front of the inn, which by now was known as East River Road rather than Farmington River Turnpike. Widening the road required removal of the front porch of the inn, eliminating access to its front door, which had been by way of the porch. Since the doorway in its original location now became useless, it was moved to its present position north of the main block (Photographs 4 and 5), where it continues to function as the main entrance to the inn. The doorway consists of a paneled door flanked by sidelights, over panels, and fluted pilasters under a blind fan of two stages, the whole capped by a gabled molding.

# National Register of Historic Places Continuation Sheet

Old Riverton Inn  
Barkhamsted, CT

Section number 7 Page 1

---

The porch appears in all historic photographs of the inn, indicating that it may have been added soon after the Civil War. The Italianate-style character of the porch supports this hypothesis. Its posts consist of square pedestals, chamfered or octagonal columns, and plain capitals. The roof overhang is not bracketed, but instead supports pairs of tapered round drop finials. The question of what the access to the front door was prior to the Italianate porch is unanswered. The 2-over-2 windows throughout the building may also date from about the time of the porch.

The question of exactly when the inn was built also is unanswered. By tradition, it dates from 1796, but the source of the tradition has not been identified.<sup>2</sup> Examination of the land records clearly shows a chain of ownership back to Jesse Ives in the early 19th century, but is not definitive on date of construction or whether he erected the building or bought it standing. See attached Abstract of Chain of Title.

Judging by stylistic features, a date early in the 19th century seems more likely than one in the late 18th century. The fine Federal details of the entrance (Photograph 4), quarter-round gable-end windows (Photographs 2 and 5), paneled pilasters supporting frieze of triglyphs with guttae, dentil course, and mutules (Photo 6), and Adamesque interior finishes (Photograph 7) are unlikely to have found their way to this remote country location much before c. 1811, the date associated with acquisition of the property by Jesse Ives.

Another detail of dating not altogether clear is the question of whether the main block and ell were built at one time, or whether the ell is an addition. By tradition they were built<sup>3</sup> at the same time. There is no mention or thought in local history to the contrary.<sup>3</sup> Yet examination of the attic framing suggests that the ell is an addition. In Photograph 8 the two central rafters are rafters of the framing of the main block. To left and right at the top are rafters of the ell. Roof sheathing on the main block rafters is visible to left and right, with the sheathing apparently removed between one pair of rafters to permit walking from the attic of the ell forward to the attic of the main block. The import is that the main block rafters existed first and were covered with sheathing to accept shingles and the original framing was upset to provide for addition of the ell. If the ell is added, it is an early addition.

Prior to c. 1940, a ground-level front door led to two public spaces in the basement, a bar room and a dining room. In the c. 1940 alterations, this door was eliminated and the two rooms were opened up into a single space, which serves as the dining room. (Photograph 9) The beamed ceiling, not structural, uses timbers from the former carriage house visible in Photograph 2. The bay window to the left in Photograph 9 (seen from the exterior in Photograph 1) dates from c. 1940. There is a full basement under the ground floor of the main block; with the attic, there are five levels in the building. The presence of the basement only under the main block adds support to the proposition that it was built first. The presence of five levels, an ambitious building program, also suggests that the building may have been constructed in the first instance as a tavern rather than a nome.

United States Department of the Interior  
National Park Service

National Register of Historic Places  
Continuation Sheet

Old Riverton Inn  
Barkhamsted, CT

Section number 7 Page 2

---

A small central stairway from the ground floor, removed in the c. 1940 alterations, led up to the lobby floor, which ceased to serve that function when the main doorway was moved. The former lobby space has been subdivided into additional guest rooms, of which the Inn now has 12. Original guest rooms on this floor feature Adamesque details, such as the mantelpiece shown in Photograph 7 where slender paired fluted pilasters support elliptical rosettes in an architrave, frieze, and cornice that break out over the pilasters. Panels under the windows in these rooms are bordered with miniature rope moldings. Guest rooms on the floor above are less elaborately detailed; fireplace surrounds are plain. Most doors in the upper floors are four-panel, apparently original.

The mid-20th-century north-side frame additions house the present lobby, bar, meeting rooms, and a luxury suite. (Photograph 5) Exterior details repeat some of the Federal features. (Photograph 10)

<sup>1</sup> A section of the wall in the level below the pictured fireplace, now the kitchen, is covered over, but suspected to have a corresponding fireplace. If so, it would be the second, but in the same stack as the visible artifact.

<sup>2</sup> Orville H. Ripley in his Sesqui-Centennial of Barkhamsted, Conn. (Hartford: Case, Lockwood & Brainard Co., 1930), pp. 60, 61, states that the inn was "erected about 1800," but cites no authority or source for the year.

<sup>3</sup> See Richard G. Wheeler and George Hilton, eds., Barkhamsted Heritage (Barkhamsted Historical Society, Inc., 1975), pp. 30, 32-33, 35, 138, 147, 153-154, 157, 177, 218, 220.

**8. Statement of Significance**

Certifying official has considered the significance of this property in relation to other properties:

nationally     statewide     locally

Applicable National Register Criteria     A     B     C     D

Criteria Considerations (Exceptions)     A     B     C     D     E     F     G

Areas of Significance (enter categories from instructions)

Commerce  
\_\_\_\_\_  
\_\_\_\_\_  
\_\_\_\_\_  
\_\_\_\_\_

Period of Significance

c. 1811 - 1942  
\_\_\_\_\_  
\_\_\_\_\_

Significant Dates

c. 1811 - 1942  
\_\_\_\_\_  
\_\_\_\_\_

Cultural Affiliation

NA  
\_\_\_\_\_  
\_\_\_\_\_

Significant Person

NA  
\_\_\_\_\_

Architect/Builder

Jesse Ives ?  
\_\_\_\_\_  
\_\_\_\_\_

State significance of property, and justify criteria, criteria considerations, and areas and periods of significance noted above.

The Old Riverton Inn is significant historically because of its impressive continuity of service to the traveling public with food and lodging for nearly two centuries. Located at a bridge crossing of the Farmington River Turnpike with connections to New Hartford to the South, Winsted to the southwest, and Colebrook and Massachusetts to the north, the inn benefited from its advantageous location to become a local landmark. Its stability of function has prevailed though the stewardship of some 12 inn keepers.

History

The community of Riverton in the Town of Barkhamsted was settled in the fourth quarter of the 18th century by farmers, one of whom was John Ives. The bridge across the east branch of the Farmington River, built in 1790, was the only bridge over the river north of New Hartford and south of the Massachusetts line and had connections to Winsted and Colebrook. Since the bridge caused a density of traffic, it was a logical location for a tavern. John Ives's grandson Jesse grasped the opportunity c. 1811.

At that time Riverton had begun to assume an industrial character because of its abundant waterpower, provided by the Farmington river. There were gristmills and sawmills, then an iron forge, a paper mill, calico manufacturer, coffee grinder, rule manufacturer, and a maker of scythes. The most famous of the manufactories was the chair factory started by Lambert Hitchcock in 1818. The village was known for a time as Hitchcocksville. Hitchcock continued the chair factory, with dubious success, at times assisted financially by Jesse Ives, until 1842. Others continued the business to 1853. Thereafter the buildings were used for other purposes until the chair factory was revived, from time to time, in mid-20th century.<sup>1</sup>

The coming and going associated with the industrial activity was beneficial to the tavern business, which Jesse Ives continued for 45 years, until 1856.<sup>2</sup> New Hartford to the east was another industrial center. Several rival stage companies operated between the two centers, using taverns such as Ives Tavern as stops.<sup>3</sup> One

See continuation sheet

Bibliographical references

- Barkhamsted Assessor's records.
- Barkhamsted Land Records
- Mountain County Herald, 23 June 1855.
- Ripley, Orville H. Sesqui-Centennial of Barkhamsted, Conn. Hartford: Case, Lockwood & Brainard Co., 1930.
- Roberts, Douglas. Municipal Historian. Interview, 26 November 1991.
- Smiley, Edmund L. A Short History of Riverton, Connecticut. Privately printed, 1934.
- Wheeler, Richard G. and Hilton, George, eds. Barkhamsted Heritage. Barkhamsted: American Revolution Bicentennial Steering Committee, 1975.
- Zucco, Mildred G., who was employed at the Inn prior to 1940. Recollections, recounted by Mark Telford, present innkeeper, 26 November 1991.

See continuation sheet

Previous documentation on file (NPS):

- preliminary determination of individual listing (36 CFR 67) has been requested
- previously listed in the National Register
- previously determined eligible by the National Register
- designated a National Historic Landmark
- recorded by Historic American Buildings Survey # \_\_\_\_\_
- recorded by Historic American Engineering Record # \_\_\_\_\_

Primary location of additional data:

- State historic preservation office
- Other State agency
- Federal agency
- Local government
- University
- Other

Specify repository: \_\_\_\_\_

10. Geographical Data

Acreeage of property Less than one

UTM References

A 

1	8
---	---

6	6	4	2	0	0
---	---	---	---	---	---

4	6	4	7	3	4	0
---	---	---	---	---	---	---

Zone      Easting      Northing

B 

--	--

--	--	--	--	--	--

--	--	--	--	--	--	--

Zone      Easting      Northing

C 

--	--

--	--	--	--	--	--

--	--	--	--	--	--	--

D 

--	--

--	--	--	--	--	--

--	--	--	--	--	--	--

See continuation sheet

Verbal Boundary Description

The nominated property is is described at Barkhamsted Land Records, volume 63, page 448.

See continuation sheet

Boundary Justification

The land records indicate that the boundary of the propery has not changed since the early 19th century.

See continuation sheet

11. Form Prepared By Reviewed by John Herzan, National Register Coordinator

name/title David F. Ransom  
 organization Architectural Historian date February 1992  
 street & number 33 Sunrise Hill Drive telephone 203 521-2518  
 city or town West Hartford state CT zip code 06107

United States Department of the Interior  
National Park ServiceNational Register of Historic Places  
Continuation SheetOld Riverton Inn  
Barkhamsted, CTSection number 8 Page 1

traveler who arrived by stage recorded his visit in a newspaper account reading, "In the village of Hitchcocksville we stopped at the residence of Jesse Ives, Esq.,...and spent the night with him. Mr. Ives is 74 years of age, and having spent his whole life in this town, and fulfilled many offices of trust and honor, is intimately acquainted with its history."<sup>4</sup>

The fact that the only bridge north of New Hartford over the Farmington River was directly in front of the inn, connecting at the inn with the turnpike north to Massachusetts, was beneficial for trade. A road also led directly west to Winsted from the bridge. The excellence of the location as a site for an inn was demonstrated by the continued use of the property for its original purpose through the series of owners named in the Abstract of Chain of Title, continuing to the present time.

When the Connecticut Western Railroad opened its right of way in 1871 through Winsted rather than Riverton, Riverton's prosperity as a manufacturing center declined. The tavern or inn nonetheless continued through the decades, with indications of hard times reflected in the land records as foreclosures perhaps in 1869, when the railroad's plans became known, and again in 1928 and 1937, during the era of the Great Depression. Following the period of World War II when the inn was used to house migrant workers, the owners prior to the present innkeeper carried on successfully for 33 years, while the present owner has conducted, thus far, 12 years of satisfactory operations. The Old Riverton Inn seems solidly on the way to achieving its second full century of service.

#### Architecture

The Old Riverton Inn complex as it now exists consists of the historic structure and mid-20th-century additions. The historic structure itself is comprised of Federal and Italianate features. The building does not have integrity of any one period or style. Nonetheless, many fine features of the Federal style, as enumerated in Section 7, continue to be displayed, and the Italianate porch is an alteration which has taken on architectural significance in its own right. The inn, as shown in Photographs 1 and 2, continues to exhibit its original form, shape, and mass with significant original characteristics and with alterations which themselves are significant.

The 20th-century alterations fortunately are all on the north side, easily and clearly identifiable. The increased revenues generated by the additions made possible the continued historic use in the 20th century. The inn is a historic building which has responded over two centuries to changing economic pressures, successfully achieving a remarkable life span of continuous use. Its architectural development and historic integrity of use are parallel tracks in its achievement of historic and architectural significance.

United States Department of the Interior  
National Park Service

National Register of Historic Places  
Continuation Sheet

Old Riverton Inn  
Barkhamsted, CT

Section number 8 Page 2

---

1 This account of Riverton's early history is taken from Richard G. Wheeler and George Hilton, eds., Barkhamsted Heritage (Barkhamsted: American Revolution Bicentennial Steering Committee, 1975), pp. 152-154, 220, 277.

2 In addition to operating the inn and assisting Hitchcock in the chair-manufacturing business, Jesse Ives was a leader in establishing St. Paul's Church (listed in the National Register of Historic Places) and was judge of the probate court (Ripley). Oral tradition, repeated by Professor Kenneth Feder of Central Connecticut State University, has it that Ives kept a journal which was at the inn until the 1930s, when it is said to have been borrowed by the Reverend Smiley, never to be seen again. Should the Ives journal reappear, it no doubt would contain useful information about the origin and early operation of the inn.

<sup>3</sup> Edmund L. Smiley, A Short History of Riverton, Connecticut (Privately printed, 1934), p. 7.

4 (Winsted) Mountain County Herald, 23 June 1855, 2:4, 5.



United States Department of the Interior  
National Park Service

National Register of Historic Places  
Continuation Sheet

Old Riverton Inn  
Barkhamsted, CT

Section number 8 Page 3

---

Abstract of Chain of Title

References are to volume and page of Barkhamsted Land Records

- 63/488, 5 October 1979 - James P. and Mildred G. Zucco to Mark Telford, one acre +/- bounded:  
North - N/F Ernest Jordan  
East - Calvin Slade  
South - Mountain Road  
West - Route 20, State Highway
- 36/166, 5 August 1946 - Richard L. Miller of Port Washington, Long Island, to Mildred L. Gregg and Joseph P. Zucco, one acre with hotel known as Old Riverton Inn bounded:  
North - James Smith (now Ernest Jordan)  
East - Mrs. Oakes (now Calvin Slade)  
South - Highway  
West - State Highway 20
- 31/417, 13 March 1937 - Wilbur G. Manchester to Richard L. Miller, Port Washington, one acre with hotel, barn, and other buildings bounded as above, "being the Riverton Inn property..."
- 34/350, 8 February 1937 - Mortgage of Philemon J. Dessosier to William L. Manchester, 30/404, 5, 6, 7 December 1928, upon complaint of Wilbur G. Manchester against Florence H. Grocock and Cora M. Holmes and Eric C. Holmes, owners of the equity of redemption of said premises and Florence E. Bishop, Thomas S. Bourbe [sp?] and Edward Schlfah [sp?] having an interest therein on 9 November 1936, one acre, etc., bounded as above. Title becomes absolute this date.
- 30/404, 7 December 1928 - Mortgage, Philemon J. Dessosier to William L. Manchester, premises this day conveyed to PJD by Frank H. Tarkington as receiver in action of Mary E. Smith vs. Thomas E. Smith.
- 30/399, 7 December 1928 - Frank H. Tarkington, receiver appointed by the court, to PJD, one acre, as above.
- 27/505, 7 November 1921 - George L. Fairchild and Edward A. Fairchild to Mary Effie Smith and Thomas H. Smith of Borough of Manhattan, New York County, State of New York, the Riverton Hotel property, one acre, as above.

United States Department of the Interior  
National Park Service

National Register of Historic Places  
Continuation Sheet

Old Riverton Inn  
Barkhamsted, CT

Section number 8 Page 4

---

- 28/530, 23 May 1921 - Dennis P. Sullivan, administrator of the estate of Michael C. Sullivan, to George and Edward Fairchild, Riverton Hotel property, as above.
- 28/29, 23 September 1908, received for record 7 May 1914 - Dennis P. Sullivan to Michael C. Sullivan, one-half hotel property in Riverton.
- 27/13, 9 April 1908 - Leroy E. Millard to Dennis P. Sullivan, the Riverton Hotel property, one acre, and personal property per inventory of furniture, curtains, bottles, bar, etc.
- 27/12, 2 April 1908 - Edmund Yale to Leroy E. Millard, Riverton Hotel property with personal property per inventory.
- 24/474, 13 April 1891 - Julia F. Flint and James L. Flint of New Britain, Bradley G. Lee and Belle F. Lee of St. Louis to Edmund Yale, 5/8 acre with buildings and all the furniture in the buildings, bounded:  
North - Abner S. West  
East - Ephriam Oakes  
West - S. West and highway  
South - Highway
- 22/614, 22 January 1885 - Court of Probate re James Austin Lee, deceased, to Bradley Lee, St. Louis, and Julia L. Flint, New Britain, hotel, barn, and other buildings, 5/8 acre, bounded:  
North - Coburn [sp?] S. Heart  
East - Ephriam Oakes  
South and West - Highway and Abner S. Hart
- 23/40, 1 February 1882 - Hiram C. Brown to Austin Lee, 5/8 acre "known as the Old Ives Hotel Place," bounded:  
North - Abner S. Hart  
East - Ephriam Oakes  
South - Highway  
West - Farmington River Turnpike and Abner S. Hart
- 20/166, 16 March, 1869 - Mortgage, William Gabriel to Hiram C. Brown. [While the record is difficult to read, it appears that this mortgage was discharged. Nonetheless, this chain of title depends on either the mortgage being foreclosed or there being another instrument, not found, of said transfer.]
- 16/526, 19 August 1856 - Trustees of estate of Jesse L. Ives to William, Gabriel, 1/2 acre, bounded:  
North - Jared Deming, George Ransom  
East - Ephriam Oakes  
South - Highway  
West - Farmington River Turnpike and Jared Deming

United States Department of the Interior  
National Park Service

**National Register of Historic Places  
Continuation Sheet**

Old Riverton Inn  
Barkhamsted, CT

Section number 8 Page 5

---

[The above chain of title back to Jesse Ives seems reasonably reliable. The question of acquisition of the property by Ives is not clear. The following entries may bear on the issue.]

9/117, 19 July 1819 - George Deming to Jesse L. Ives, dwelling house standing partly on land belonging to heirs of Petatiah Ransom and partly on Farmington River Turnpike.

8/11, 3 April 1813 - Eli Ransom to Petatiah Ransom, one acre +/- lying of north side of road leading up the mountain with "one-half barn standing near said Petatiah's now [sp?, new?] dwelling house," bounded:

South and East - said road  
West - turnpike road  
North - Widow Ransom

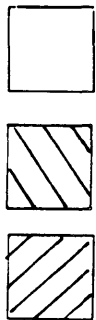
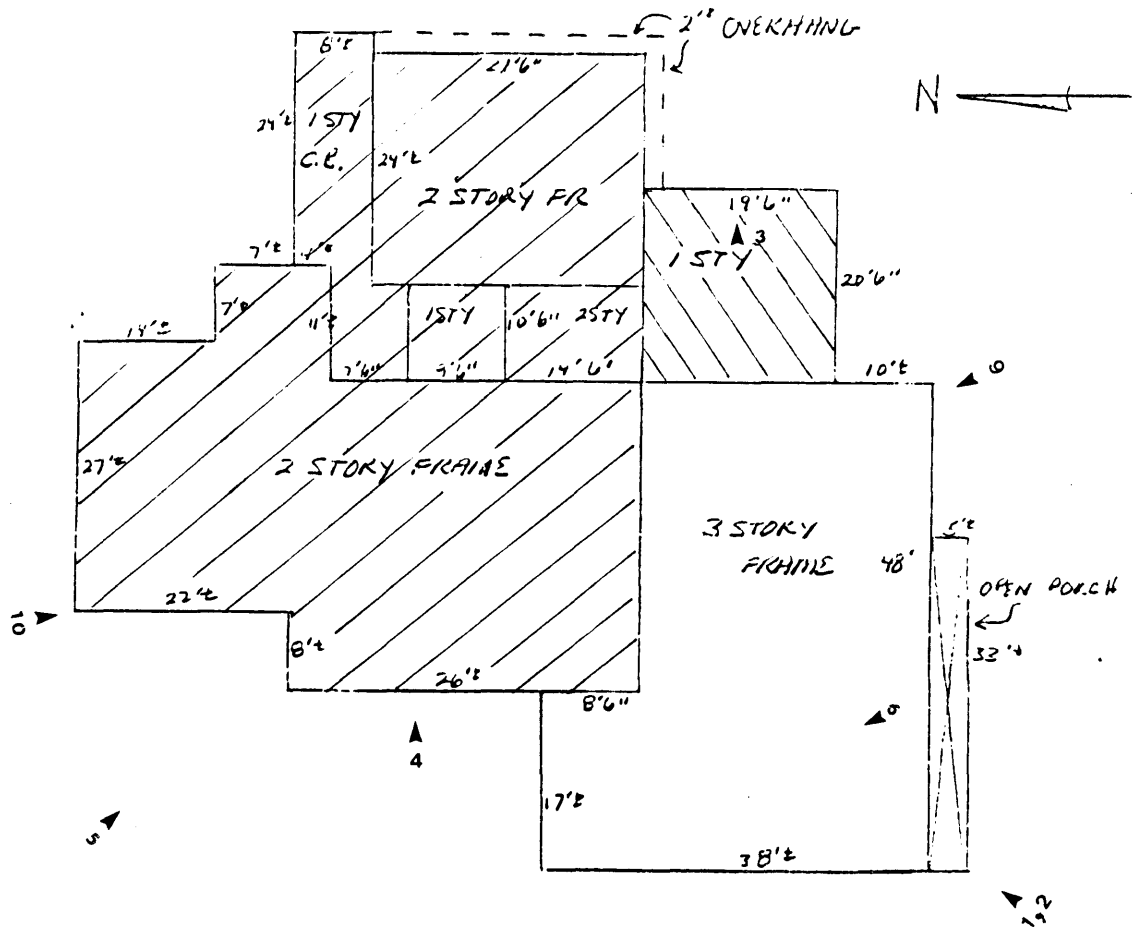

1796/1818 inn

Possible original house

Mid-20C additions

Old Riverton Inn  
 Barkhamsted, CT  
 Ground Plan  
 Photo Key

United States Department of the Interior  
National Park Service

National Register of Historic Places  
Continuation Sheet

Old Riverton Inn  
Barkhamsted, CT

Section number Photos Page \_\_\_\_\_

---

Photographs were taken (or copied in the case of Photograph 2) by D.F. Ransom in November 1991.

Negatives are on file at the Connecticut Historical Commission

Photograph 1  
View northeast

Photograph 2  
Historic photograph  
View northeast

Photograph 3  
Early fireplace  
View east

Photograph 4  
Front doorway  
View east

Photograph 5  
View southeast

Photograph 6  
Cornice at southeast  
corner  
View northwest

Photograph 7  
Second-floor bedroom  
Fireplace mantel  
View northeast

Photograph 8  
Attic framing  
View west from ell into  
main block

Photograph 9  
Dining room  
View northwest

Photograph 10  
Cornice at northwest corner  
View southeast