

4402



United States Department of the Interior
National Park Service

National Register of Historic Places Registration Form

This form is for use in nominating or requesting determinations for individual properties and districts. See instructions in National Register Bulletin, *How to Complete the National Register of Historic Places Registration Form*. If any item does not apply to the property being documented, enter "N/A" for "not applicable." For functions, architectural classification, materials, and areas of significance, enter only categories and subcategories from the instructions.

1. Name of Property

Historic name: Federal Building and U.S. Courthouse

Other names/site number: James A. McClure Federal Building and U.S. Courthouse

Name of related multiple property listing:

N/A

(Enter "N/A" if property is not part of a multiple property listing)

2. Location

Street & number: 550 W. Fort Street

City or town: Boise State: Idaho County: Ada

Not For Publication: Vicinity: N/A

3. State/Federal Agency Certification

As the designated authority under the National Historic Preservation Act, as amended,

I hereby certify that this X nomination request for determination of eligibility meets the documentation standards for registering properties in the National Register of Historic Places and meets the procedural and professional requirements set forth in 36 CFR Part 60.

In my opinion, the property X meets does not meet the National Register Criteria. I recommend that this property be considered significant at the following level(s) of significance:

 national X statewide X local

Applicable National Register Criteria:

X A B X C D

	<u>8/6/2019</u>
Signature of certifying official/Title:	Date
Federal Preservation Officer, U.S. General Services Administration	
State or Federal agency/bureau or Tribal Government	

Federal Building and U.S. Courthouse
Name of Property

Ada Co., ID
County and State

In my opinion, the property meets ___ does not meet the National Register criteria.

[Signature] _____ 6-4-19
Signature of commenting official: Date

Deputy SAPO _____
Title: State or Federal agency/bureau
or Tribal Government

4. National Park Service Certification

I hereby certify that this property is:

- entered in the National Register
- determined eligible for the National Register
- determined not eligible for the National Register
- removed from the National Register
- other (explain:)

[Signature] _____ 9/19/2019
Signature of the Keeper Date of Action

5. Classification

Ownership of Property

(Check as many boxes as apply.)

- Private:
- Public – Local
- Public – State
- Public – Federal

Category of Property

(Check only one box.)

- Building(s)
-

Federal Building and U.S. Courthouse
Name of Property

Ada Co., ID
County and State

District

Site

Structure

Object

Number of Resources within Property

(Do not include previously listed resources in the count)

Contributing	Noncontributing	
<u>1</u>	<u>1</u>	buildings
<u> </u>	<u>1</u>	sites
<u>1</u>	<u> </u>	structures
<u> </u>	<u> </u>	objects
<u>2</u>	<u>2</u>	Total

Number of contributing resources previously listed in the National Register N/A

6. Function or Use

Historic Functions

(Enter categories from instructions.)

GOVERNMENT: government office

GOVERNMENT: courthouse

Current Functions

(Enter categories from instructions.)

GOVERNMENT: government office

GOVERNMENT: courthouse

Federal Building and U.S. Courthouse
Name of Property

Ada Co., ID
County and State

7. Description

Architectural Classification

(Enter categories from instructions.)

MODERN MOVEMENT: New Formalism

Materials: (enter categories from instructions.)

Principal exterior materials of the property:

foundation: CONCRETE

walls: GLASS

CONCRETE

roof: SYNTHETIC

other: METAL/Aluminum

Narrative Description

(Describe the historic and current physical appearance and condition of the property. Describe contributing and noncontributing resources if applicable. Begin with a **summary paragraph** that briefly describes the general characteristics of the property, such as its location, type, style, method of construction, setting, size, and significant features. Indicate whether the property has historic integrity.)

Summary Paragraph

The Federal Building and U.S. Courthouse, currently named the James A. McClure Federal Building and U.S. Courthouse, is located at 550 W. Fort Street in Boise, Idaho. It sits on a landscaped site, bound by parking lots to the north and west, N. 5th Street to the east, W. Fort Street to the south, and Memorial Park west of the parking lot. Constructed from 1965-1968 by the U.S. General Services Administration (GSA), the concrete and glass building is composed of a five-story rectangular mass that cantilevers out over a two-story pedestal set on a podium that defines the basement space below. The building footprint is rectangular (125' x 305' at upper floors 3-7) with 21,925 square foot lower first and second floors and 39,425 square foot upper floors 3-7 totaling a gross floor area of 271,369 square feet. The main entrance is located on the primary west elevation which faces the west parking lot and Memorial Park. The building rises to 101 feet high at the penthouse level. The design of the exterior is simple, in the New

Federal Building and U.S. Courthouse
Name of Property

Ada Co., ID
County and State

Formalism sub-style of Modernism, with the upper mass composed of repeating light-weight concrete window modules with gray tinted glass and the lower pedestal levels enclosed by a glass curtain wall system. At the ground floor, massive concrete pilotis support a cantilevered concrete beam system and the upper floors. The ground floor visually extends out into the site resting on a granite podium. The building currently houses federal agency offices on each floor in addition to two double-height courtroom spaces on the sixth floor and three other courtrooms that were added to expand the courts in 1985. Original interior finishes and systems remain at the entrance lobby as well as within select elevator lobbies, court waiting areas, corridors and office spaces.

The building retains a high level of integrity related to the aspects of location, setting, workmanship, feeling and association since little has changed in these areas over the past fifty years. With the exception of an entry addition and plaza at the west elevation and miscellaneous landscape changes, the exterior has also been minimally impacted in relation to the aspects of design and materials, retaining a high degree of physical integrity. The original spatial organization of a central core with a double-loaded corridor loop and significant public spaces, including the entrance lobby, select upper floor elevator lobbies, the sixth-floor courtroom waiting area, and select restrooms, are intact. These spaces retain representative examples of original finishes, such as travertine, terrazzo, wood, and aluminum features. Innovative systems, for the era of construction, include the original suspended ceilings with integral lighting and mechanical diffuser system.

Narrative Description

SETTING

The City of Boise's downtown core extends northeast from the Boise River to the foothills with the Idaho State Capitol Building at its center. The Federal Building and U.S. Courthouse is sited just northeast of the State Capitol Campus at the base of the foothills (Figure 1). It is nestled in among residential neighborhoods, at the fringe of downtown development and adjacent to the Department of Veterans Affairs (VA) complex. A park-like setting is maintained to the east and west of the property by the VA complex, which retains an expansive open lawn that originally served as the Fort Boise parade ground, and the city's Memorial Park, abutting the west property line and expanding west across N. 6th Street (Figure 3).

The site is bordered by Fort Boise which was listed on the National Register of Historic Places in 1972¹, and two National Register listed historic districts. Fort Boise, located to the north and east of the building, includes a collection of stone and brick buildings constructed around the original parade ground lawns, as well as a small stone guard station (c.1886) located immediately adjacent to the east property line along W. 5th Street (see Photo 8). Fort Boise is now the

¹ Wells, Merle. "National Register of Historic Places Nomination Form - Fort Boise (72000433)." *National Park Service*, National Archives and Records Administration, 9 Nov. 1972. Accessed January 14, 2016 from catalog.archives.gov/id/84248868.

Federal Building and U.S. Courthouse
Name of Property

Ada Co., ID
County and State

Department of Veterans Affairs Medical Center. To the northwest, the North End Historic District was the city's first "suburban" development, platted initially in 1878 and developing more rapidly by 1891 as a working- and middle-class neighborhood. To the southwest, the locally designated Hays Street Historic District was originally a residential neighborhood developed most intensely at the turn of the twentieth century, covering twenty-two blocks of the northern half of the original Boise Townsite. Although originally a primarily residential neighborhood, the Hays Street Historic District has transitioned from a residential neighborhood to its current mix of multi-family and office uses.²

Other notable features near the building site include the John A. O'Farrell Cabin and Memorial Park. The single-room O'Farrell cabin was the first permanent home in Boise, constructed in 1863. It was moved in 1911 to its current location on W. Fort Street – east of the Federal Building and U.S. Courthouse. Memorial Park provides grassy open space along the northwest boundary of the Federal Building and U.S. Courthouse.

SITE

The Federal Building and U.S. Courthouse site occupies 332,360 square feet bound by W. Fort Street at a diagonal to the south, N. 5th Street (entry to the VA complex) to the east, the VA Medical Center and the foothills to the north, and Memorial Park to the west. The property line is set back from W. Fort Street, delineated by a chain-link fence centered in a landscaped area between the sidewalk and the vehicular access ramp to the basement parking. It is also set back from N. 5th Street by a deeper landscaped area between the sidewalk and the building that features mature trees and pedestrian walkways. The north property line generally follows the shape of the parking lot creating a slender northward extension of parking behind the VA buildings. The west property line runs between the parking lot and Memorial Park. No alterations to the property line have occurred since its establishment. (See Figures 3 and 4).

Within the boundary is the 271,369 gross square foot building, entry plaza, security guard station, parking lot, vehicular ramp to below-grade basement parking located under the podium (see Photo 7), mechanical enclosure in the north parking lot, walkways, and landscaping (only the building and mechanical enclosure are contributing resources). The building is located toward the southeast quarter of the site with asphalt paved parking wrapping the remaining west and north portions and extending north behind the adjacent VA property. A secure vehicular entry point with a single non-original guard station is located east of the intersection of N. 6th Street and W. Fort Street. The mechanical enclosure is in the parking lot north of the building (see Photo 9).

Low height landscaping provides a small buffer between the building and parking lots. Deeper landscape areas with taller plantings and mature trees provide more substantial buffers between the building and N. 5th Street and W. Fort Street. In general landscaping includes lawn and

² Summarization of historic district descriptions and maps available through City of Boise website. "Boise's Historic Districts." *Transportation – City of Boise*. Accessed December 10, 2018. pds.cityofboise.org/planning/hp/districtsmap/.

Federal Building and U.S. Courthouse
Name of Property

Ada Co., ID
County and State

established deciduous and coniferous trees, as well as low shrubs. Unfinished chain-link fencing on a concrete curb, low concrete walls, and a ha-ha wall (i.e. a recessed landscape element that creates a vertical barrier while preserving the view of the landscape beyond) provide security barriers for the north, east, and south perimeters. The west perimeter is open to the park (Figure 16). Building signage in the form of a low concrete monument sign is located east of the main vehicular entry drive.

BUILDING CONSTRUCTION

The Federal Building and U.S. Courthouse is composed of a five-story rectangular mass that cantilevers out over a two-story pedestal set on a podium that defines the basement space below. The building rises to 101 feet at the penthouse level and encompasses 271,369 gross square feet. The building is constructed of reinforced concrete through the third floor and structural steel with lightweight concrete fill on cellular steel decking above (see Figures 10 and 11). The pedestal level features exposed massive post-tensioned concrete beams with 16-foot cantilever extensions supported by equally massive concrete pilotis spaced to create 25-foot bays. Due to the soil conditions left by Cottonwood Creek, which once crossed the site, the foundation system is established on point-bearing piles driven down to the stable surface below the creek runoff soil.

BUILDING EXTERIOR

The design of the exterior is simple and clean arranged horizontally as a two-story recessed pedestal topped by a five-story mass. At the upper mass, the elevations are composed vertically of 25-foot-wide bays established by the exposed structural pilotis and beams and subdivided into 5-foot increments by the architectural precast concrete window modules. The west and east elevations feature eleven bays while the north and south elevations are composed of four bays (see Photos 1-6). At the pedestal level, continuous glass curtain wall encloses the recessed first floor and mezzanine, passing behind the structural pilotis. The curtain wall is subdivided similar to the architectural precast concrete window modules above with vertical mullions creating roughly 5-foot bays and a horizontal mullion aligning with the second-floor line. The flat roof is clad in a membrane system with rock ballast and a metal clad penthouse contains a window washing machine on rails.

The building employs a limited palette of materials and colors. Concrete structural members are unfinished with a bush-hammered texture. The pedestal curtain wall is constructed of aluminum framing and gray tinted glass. Architectural precast concrete window units used for the upper mass are composed of expanded shale aggregate concrete and white Portland cement and feature gray tinted glass set deep in the precast module with a single horizontal mullion creating a transom (Figure 13). These modules were manufactured by Otto Buehner & Company out of Salt Lake City, Utah (Figure 7).

The primary entry is on the west elevation with secondary entries, now limited to exiting, on the other three elevations. Originally the entry was minimalist with three pairs of aluminum-framed glass doors with a signage strip above the door. The glass curtain wall, doors, and signage were

Federal Building and U.S. Courthouse
Name of Property

Ada Co., ID
County and State

removed from two bays of the structure and a new entry addition was constructed projecting west over the podium in 2004. Implemented as part of the First Impressions Program aimed at improving and modernizing aging federal building lobbies and plazas, the entry addition expanded the interior lobby and provided space for modern security needs. The addition is about a quarter of the length of the original building, roughly two bays just south of center on the west elevation. It is comprised of a central solid vertical feature with flat roofs extending north and south at two different levels – below the existing cantilevered beams to the north of the vertical over the entry doors and aligning with the top of the existing beams over the lobby volume to the south. The west entrance elevation of the addition is transparent utilizing glass walls with two pairs of metal doors (Photos 2 and 3). The lobby volume is enclosed by a gridded curtain wall with perforated solar shading devices. Its south wall is angled out from grade level to the roof in contrast to the plumb vertical delineation of the original building grid. The entry addition was designed by Hummel Architects, the contemporary evolution of original architects Hummel Hummel Jones & Shawver.

The ground floor of the building extends out into the site with a low granite podium that encircles the building. The podium features a low horizontal perimeter guardrail of stone. The podium is accessed by a non-original stair and ramp at the west elevation from the west plaza, by an original ramp and stair at the north elevation from the parking area lot, and by an original stair at the south elevation from a walkway through the landscaping to W. Fort Street. The podium also features the granite dedication cornerstone at the south corner of the east elevation (Photo 10). The cornerstone reads:

United States of America
Lyndon B. Johnson
President
General Services Administration
Lawson B. Knott Jr.
Administrator
1966

A plaza consisting of a curved paved area, planter, and stairs radiating from the entry addition west toward the parking lot was added in 2015. This plaza also includes a flag pole and contemporary security lighting and bollards. The vehicular entry has also been altered over time to include reconfigured lanes, security bollards and gates, and a simple rectangular guard booth. The booth, located between the entry and exit lanes from W. Fort Street to the parking lot, has a granite base, windows, and a flat roof. A new curving concrete monument sign was installed near the vehicular entrance from W. Fort Street, as part of the 2015 site work, that reads:

James A. McClure
Federal Building and
United States Courthouse
550 West Fort Street

Federal Building and U.S. Courthouse
Name of Property

Ada Co., ID
County and State

Mechanical equipment located north of the building in the parking lot is screened by an original mechanical enclosure of architectural precast concrete units repeating the rhythm of the building's precast window units. The enclosure is surrounded and softened by shrubbery.

BUILDING INTERIOR

The Federal Building and U.S. Courthouse offers 173,858 square feet of office space - typically 39,425 square feet per floor. The organizing concept for the typical floor plan is a central core that includes a lobby, elevators, stairs, mechanical spaces and restrooms encircled by a double-loaded corridor loop. The lower two floors are recessed 16 feet to form the pedestal with the corridor at the perimeter encircling the core and office or public space. The original concept was for open and flexible tenant office space to accommodate the constant change. The basement houses mechanical systems, janitorial, storage, and maintenance spaces, and a limited amount of secure parking. The penthouse also houses building systems, as well as the original window washing machine that, when operational, moved around the perimeter of the roof on a track and supported a swing stage the width of five window bays.

First Floor

The first floor is composed of the 2004 entry addition which is a two-story volume that houses building security and screening equipment and leads to the original west lobby (Photo 12). From the west lobby there is a direct view through the elevator lobby to the east lobby and beyond the curtain wall enclosure to the Fort Boise parade grounds east of the building (Photo 11). The north and south ends of the first floor contain offices inboard of the corridor loop. Original first floor lobby and corridor finishes include Colorado walnut travertine clad walls, a dark wood slat ceiling, small square light fixtures recessed in the slats, and aluminum clad elevator openings, alcoves, and glass storefront partitions (Photo 13). The west lobby also features two large circular aluminum wall-mounted seals. Alterations to first floor finishes in the lobbies and corridor include removal of original granite flooring, full carpeting throughout, and additional larger square ceiling mounted light fixtures. Tenant space finishes vary.

Second Floor

Like the first floor, the second floor is composed of office spaces inboard of the corridor loop. The corridor features the same original wood slat ceiling and small square recessed light fixtures retrofitted with additional larger ceiling mounted fixtures (Photo 16). The second-floor elevator lobby is representative of most upper floor elevator lobbies on office floors that do not have courtrooms. Lobby finishes are much simpler than the first floor and court floors, featuring painted walls, painted elevator surrounds and doors, carpet and the original suspended ceiling system found throughout the building's upper five floors (Photo 14). At the west end of the second-floor lobby the once exterior curtain wall was replaced with floor to ceiling aluminum storefront to allow views into the entry addition.

Federal Building and U.S. Courthouse
Name of Property

Ada Co., ID
County and State

Upper Floors

Upper floors other than the fifth and sixth court floors feature simple elevator lobbies similar to the second floor. Lobby finishes are continued in the corridor loop including full carpeting (Photos 17 and 18). Most tenant spaces have been remodeled over time with permanent stud and gypsum board partition walls, new floor finishes, and furnishings (Photos 15 and 19), however representatives of original finishes including asbestos composite tile (ACT) flooring and moveable partition walls that lock into the suspended ceiling grid system can still be found in some tenant spaces. Most spaces maintain the original suspended ceiling grid with integral flush light fixtures and mechanical diffusers that supply air through the linear grid system rather than the panels – an innovation of the late 1960s³.

The fifth and sixth floors have public courtrooms and therefore feature a higher level of finishes in the elevator lobbies, public corridors and court waiting areas. The original courtrooms are on the sixth floor and the elevator lobby, corridors, and waiting areas feature original terrazzo floors, Colorado walnut travertine clad walls, aluminum clad elevator openings, aluminum framed glass partition walls and doors, solid oak doors and trim, and suspended ceiling system (Photos 21 and 22). The fifth-floor courtrooms were later additions and the elevator lobby, corridors, and waiting area feature contemporary materials (Photo 25).

Courtrooms

Two original courtrooms are located on the sixth floor inboard of the corridor loop on either side of the elevator core. At each of these two courtrooms, double doors from the waiting area lead to an original two-story volume courtroom (that takes up space from the seventh floor). Finishes and furnishings in these courtrooms have been replaced and now include carpeting, cherry wood furnishings and trim, travertine and gypsum walls, and a decorative ceiling with suspended light fixtures (Photo 23). Both courtrooms are the same.

An additional double-height courtroom was added c.1985 to the north end of the sixth floor (Photo 24), as well as two single-story high courtrooms on the fifth floor (Photo 26). The additional courtrooms feature wood paneled walls, carpeting, and solid ceilings.

Restrooms

Restrooms and janitorial spaces that retain a combination of square and rectangular ceramic tile surfaces and metal toilet partitions in a pastel color palette, such as pink or peach tile and blue partitions, are representative of original finishes (Photo 20). Most also feature original porcelain fixtures and aluminum accessories typical of the period. The first-floor restrooms have been remodeled, but a majority of the upper floor public restrooms at both the elevator cores, and north and south corners inboard of the corridor are intact.

³ See narrative statement of significance for more information on the suspended ceiling system.

Federal Building and U.S. Courthouse
Name of Property

Ada Co., ID
County and State

ALTERATIONS

With the exception of alterations to the primary west entrance, the building exterior design and materials have been well preserved. Minor exterior alterations, such as the addition of security cameras and relocation of a railing on the east side of the podium adjacent to the vehicular ramp to the secure basement level parking under the podium, have had minimal impact to the building's integrity.

The most significant exterior alterations have been focused on the west site and main entry. The First Impressions⁴ project constructed in 2004 was intended to improve entry and egress, and increase space for contemporary security requirements. The size of the addition is modest, impacting only two bays of the west elevation at the two-story pedestal level, and reversible in its relationship to the original structure. To accommodate the new entry addition, the podium and entry site stair (Figure 6) were expanded west to maintain a consistent podium depth around the building perimeter. The podium expansion and new stairs are differentiated by material but compatible. These alterations allow the building to accommodate contemporary needs without significantly impacting the integrity of the building exterior.

Further site alterations have included reconfiguration of the vehicular entry and exit lanes to the parking lot, construction of the security guard house, the addition of a curving planter and plaza with steps radiating from the entry addition, and various security and site improvements. The west plaza and south landscape areas received security measures such as bollards around the plaza and a ha-ha security wall in the south landscape in 2015. These site alterations are modest in scale, in some cases hidden, offering modern improvements to circulation and security with minimal impact to the integrity of the site.

Overall, the significant interior spatial concepts have been well preserved. The corridor configuration on nearly all floors remains intact, sometimes with the addition of doors for security. Original sixth floor double-height courtroom spaces and associated waiting lobbies are also intact. Intact examples of the original finishes include the main first floor lobby and corridor (though the granite floor has been replaced with carpet) and the sixth-floor elevator lobbies and courtroom waiting areas - complete with two colors of terrazzo and phone alcoves. Interior alterations have predominantly focused on code required upgrades, such as accessibility and fire and life safety improvements, finish upgrades within the original tenant spaces, and system upgrades for efficiency including mechanical and electrical equipment in the basement and penthouse, as well as on each floor where the mechanical distribution is integral with the suspended ceiling system. Spatial alterations have occurred within tenant spaces without impact to the corridor configuration, including the division of the first-floor non-public spaces north and south of the elevator core, originally made up of larger spaces such as the cafeteria (no longer in

⁴ In 1998 GSA launched the First Impressions Program aimed at addressing "the decline of federal building lobbies and plazas around the nation, by extending the vision of Design Excellence into existing federally occupied buildings. First Impressions spotlights public areas that shape a visitors "First Impression" of the federal government." Accessed February 1, 2019 from <https://www.gsa.gov/real-estate/design-construction/design-excellence/first-impressions-program-overview>

Federal Building and U.S. Courthouse
Name of Property

Ada Co., ID
County and State

operation), into smaller spaces and offices and the addition of courtrooms at the fifth and sixth floors.

INTEGRITY

The property retains a high degree of exterior integrity as alterations have been largely limited to GSA's First Impressions entry addition, entry plaza, and security measures on the surrounding site. Original finishes, curtain wall system, architectural precast concrete window units, glazing, and podium design and materials remain intact. The interiors likewise retain good integrity in highly visible public areas, including lobbies (except the main floor elevator lobby flooring), public corridors, and court waiting areas. While interior finishes in private and open office tenant spaces and functional areas have been altered in order to keep up with the changing needs of tenants, these changes have occurred within spaces that were originally simple in character and designed to accommodate change over time as the needs of the building's occupants evolved. In addition, the closing off of the loop corridors has been limited to private tenant corridors on upper floors; original public corridors and spatial layouts of elevator lobbies remain in place. While the 2004 First Impressions project altered the entry experience, it left intact the structure, floors, spatial relationships and finishes of the adjacent west lobby and second floor. Throughout the building original spatial relationships in public spaces, high-quality original materials, and modern and innovative design distinguish the Federal Building and U.S. Courthouse as a regional symbolism of government strength and modernism.

Thus, the property retains integrity of location, setting, design, materials, workmanship, feeling, and association.

Location – The property is in its original location.

Setting – The property retains its original setting. The surrounding streets, neighborhoods, public park, Fort Boise structures and parade grounds, and parking lots and landscaping on the site remain largely unchanged.

Design, Materials and Workmanship – The integrity aspects of design, materials, and workmanship are interrelated. Overall, the property retains its original modern massing and design expression, simple timeless high-quality material palette, and high-quality materials and construction requiring minimal repair over time. Where changes have occurred, such as the First Impressions entry addition and associated interior alterations, they have been implemented in a reversible manner and are at a scale that does not impact the overall integrity of the building.

Feeling – With the original design, materials, and context intact at both the exterior and public interior spaces, the property continues to communicate its modern place in time and represent the federal government's presence in Boise.

Association – Since its construction, the property has continuously served as a federal building and courthouse with federal agency offices and courtrooms. This supports the understanding of the design and history.

Federal Building and U.S. Courthouse
Name of Property

Ada Co., ID
County and State

8. Statement of Significance

Applicable National Register Criteria

(Mark "x" in one or more boxes for the criteria qualifying the property for National Register listing.)

- A. Property is associated with events that have made a significant contribution to the broad patterns of our history.
- B. Property is associated with the lives of persons significant in our past.
- C. Property embodies the distinctive characteristics of a type, period, or method of construction or represents the work of a master, or possesses high artistic values, or represents a significant and distinguishable entity whose components lack individual distinction.
- D. Property has yielded, or is likely to yield, information important in prehistory or history.

Criteria Considerations

(Mark "x" in all the boxes that apply.)

- A. Owned by a religious institution or used for religious purposes
- B. Removed from its original location
- C. A birthplace or grave
- D. A cemetery
- E. A reconstructed building, object, or structure
- F. A commemorative property
- G. Less than 50 years old or achieving significance within the past 50 years

Federal Building and U.S. Courthouse
Name of Property

Ada Co., ID
County and State

Areas of Significance

(Enter categories from instructions.)

POLITICS/GOVERNMENT (Criterion A)

ARCHITECTURE (Criterion C)

Period of Significance

1967

Significant Dates

Significant Person

(Complete only if Criterion B is marked above.)

N/A

Cultural Affiliation

N/A

Architect/Builder

Hummel Hummel Jones & Shawver (Architect of Record)

Charles Luckman Associates (Consulting Architect)

Jacobsen Construction Company (Contractor)

Harry Meidell, P.E. (Structural Engineer)

Otto Buehner & Company (Architectural Precaster)

Federal Building and U.S. Courthouse
Name of Property

Ada Co., ID
County and State

Statement of Significance Summary Paragraph (Provide a summary paragraph that includes level of significance, applicable criteria, justification for the period of significance, and any applicable criteria considerations.)

The Federal Building and U.S. Courthouse, renamed the James A. McClure Federal Building and U.S. Courthouse in 2001, has local and state significance under Criterion A in the area of Politics/Government, and state-wide significance under Criterion C in the area of Architecture. The Federal Building and U.S. Courthouse is significant in that it reflects the goals of the “Guiding Principles for Federal Architecture” – a Federal initiative set forth by the Kennedy Administration in 1962. Design of the building began in 1962 and statements by the prime local architect, Charles Hummel, indicate that the solicitation, design process, and final outcome were directly influenced by the initiative. The property meets the high standard of design and quality required by the Federal Government and is indicative of designers who understood how to interpret the principles in the public realm. The project also reflected GSA’s architect/engineer selection process of the time - partnering a local architecture firm, Hummel Hummel Jones & Shawver, with a nationally recognized firm, Charles Luckman Associates. Construction of the building, bringing federal agencies scattered throughout Boise into one significant, iconic structure, provided a unified federal presence in Boise. Under Criterion C, the Federal Building and U.S. Courthouse is significant as the earliest known and successful representation of the Modern style, specifically the sub-style New Formalism, in both the City of Boise and the State of Idaho. It is a fine expression of the Modernist design philosophy, materials, and engineering, cutting edge in its materials and systems at the local and state levels. In addition to embodying modern design values, the building is considered a formative work in the portfolio of prominent Idaho architect Charles F. Hummel - named Idaho’s first Modern Master in 2012 by Idaho Modern, an advocacy committee of Preservation Idaho. It is also representative, though not recognized nationally, of the type of modern explorative design work being produced by Charles Luckman Associates at the time. The Federal Building and U.S. Courthouse was and still is the only known representation of 1960's modernism of this scale, style, and quality in the City of Boise and the only federally-owned building of its type in the State of Idaho. The period of significance is the date of construction of the building in 1967.

Narrative Statement of Significance (Provide at least **one** paragraph for each area of significance.)

CRITERION A: GOVERNMENT/POLITICS

The design of the Federal Building and U.S. Courthouse in Boise was directly influenced by two key factors – "The Guiding Principles for Federal Architecture" published in 1962 and the Modern Movement in architecture (post-WWII). These two ideologies reflected the modern desire for a uniquely American architecture, differentiated from the past, coupled with the post-war concerns of economy, efficiency, equity and innovation, and are evident in the building's siting, form, organization, materials, engineering, and overall aesthetic.

Federal Building and U.S. Courthouse
Name of Property

Ada Co., ID
County and State

Written documentation and personal interviews with the local design architect for the building, Charles Hummel, detail a design process directly influenced by the Guiding Principles. “From the inception of the project there was a clear understanding that this building was to be an exemplary demonstration of modern architecture and construction technique. GSA’s intention was emphasized by the fact that it was a GSA Washington, D.C. office project. It was noted to the design team that a high degree of design excellence was expected by the new Kennedy administration for all federal buildings and that Mrs. Kennedy, in particular, had taken a personal interest in the new Federal buildings.”⁵

The Guiding Principles for Federal Architecture

Amidst a growing backlog of construction projects and deferred maintenance, as well as growing concern over the overall quality of Federal architecture, both related to design and federal employee needs, the Ad Hoc Committee on Federal Office Space was formed by President Kennedy in 1961 to advise the administration on immediate and long-term space needs. The Committee ultimately produced a report in 1962 that laid out the “Guiding Principles for Federal Architecture”.

Several hundred construction projects were undertaken by GSA under the primary tenets of the “Guiding Principles for Federal Architecture”. These guidelines encouraged modern design that would both “provide efficient and economical facilities” and “provide visual testimony to the dignity, enterprise, vigor and stability of the American Government.” They called for the federal government not to imitate, but to serve as a model to others, embracing contemporary innovations and design.⁶

Guiding Principles set forth a three-point policy:

1. The policy shall be to provide requisite and adequate facilities in an architectural style and form which is distinguished, and which will reflect the dignity, enterprise, vigor, and stability of the American National Government. Major emphasis should be placed on the choice of designs that embody the finest contemporary American architectural thought. Specific attention should be paid to the possibilities of incorporating into such designs qualities which reflect the regional architectural traditions of that part of the Nation in which buildings are located. Where appropriate, fine art should be incorporated in the designs, with emphasis on the work of living American artists. Designs shall adhere to sound construction practice and utilize materials, methods and equipment of proven dependability. Buildings shall be economical to build, operate and maintain, and should be accessible to the handicapped.

⁵ Charles F. Hummel, narrative prepared for GSA’s Image Master Plan (c.2000) and via phone interview (2015).

⁶ Robinson & Associates, *Growth, Efficiency, and Modernism: GSA Buildings of the 1950s, 60s, and 70s*, Washington: Center for Historic Buildings, Office of the Chief Architect, U.S. General Services Administration, 2003.

Federal Building and U.S. Courthouse
Name of Property

Ada Co., ID
County and State

2. The development of an official style must be avoided. Design must flow from the architectural profession to the Government, and not vice versa. The Government should be willing to pay some additional cost to avoid excessive uniformity in design of Federal buildings. Competitions for the design of Federal buildings may be held where appropriate. The advice of distinguished architects ought to, as a rule, be sought prior to the award of important design contracts.
3. The choice and development of the building site should be considered the first step of the design process. This choice should be made in cooperation with local agencies. Special attention should be paid to the general ensemble of streets and public places of which Federal buildings will form a part. Where possible, buildings should be located so as to permit a generous development of landscape.⁷

The design of the Federal Building and U.S. Courthouse in Boise was being developed as the Guiding Principles were being established and implemented by the federal government. Architect Charles Hummel indicated in his written documentation of the design process that these ideas put forth in the principles and supported by the Kennedy administration were at the forefront of the design process and GSA's expectations for the design. The design generally followed these principles including generation of a dignified contemporary design and award of the project to a local architect paired with a nationally distinguished design architect. A public process for site selection was undertaken but did not ultimately yield a publicly supported site in downtown Boise. While the selected site did not meet all initially identified criteria, including a central downtown location and immediate adjacency to the state capitol building, it did provide space for a substantial building to consolidate federal agencies, room for landscaping, and was a short distance from the capitol. While the design did not incorporate fine art, it did employ the latest and innovative structural design and systems of the time.

CRITERION C: ARCHITECTURE

FORT BOISE AND DEVELOPMENT OF BOISE, IDAHO

Fort Boise was established by the U.S. Army Cavalry in 1863 at the base of the foothills in close proximity to the Oregon Trail. It was built to protect the gold that had been discovered in the Boise Basin around Idaho City. Boise City soon sprung up between Fort Boise and the Boise River and became a prime transportation hub in Southern Idaho. The town was flooded by settlers, stagecoach travelers, and gold miners. Early settlers built log cabins with settlements extending south of Fort Boise. These were later replaced by grander homes as the town and prosperity grew. By the early 1900s Boise boasted a large downtown infrastructure with multi-story commercial and municipal buildings.

⁷ Report to the President by the Ad Hoc Committee on Federal Office Space, June 1, 1962. Accessed March 12, 2019, from <https://www.gsa.gov/real-estate/design-construction/design-excellence/design-excellence-program/guiding-principles-for-federal-architecture>.

Federal Building and U.S. Courthouse
Name of Property

Ada Co., ID
County and State

Fort Boise began with a modest cavalry camp at the township's northern edge specializing in training horses for cavalry troops. It soon grew to include officers houses along the hills, barracks and other buildings to service the population, and an expansive cavalry parade ground extended south of the officers row. In 1919, the U.S. Public Health Service took over the site, locally known as Camp Boise or the Boise Barracks, for a tuberculosis hospital. By 1938, a Veterans hospital had opened and the buildings on the site began to be repurposed for veteran's services. The western edge of the site was transferred to Boise City Parks in 1950 to form Memorial Park. The remaining Fort Boise buildings - stone guardhouse, Officers Row houses, a sandstone warehouse, and several other warehouses and equestrian related buildings - have been adaptively reused and supplemented with contemporary buildings to continue to serve veterans today.

The portion of the site eventually allocated to GSA for construction of the new Federal Building and U.S. Courthouse was graded by the 1950s, but the land had not been used⁸. The Veterans Administration agreed to transfer the land at the southwest corner of the site to GSA since it was vacant, and they had no future plans for its use.

Development of the Federal Building and U.S. Courthouse⁹

During the summer of 1961, the GSA awarded a professional services contract to the Boise firm of Hummel Hummel & Jones (renamed Hummel Hummel Jones & Shawver during design) for the design of the Federal Building and U.S. Courthouse to be located in downtown Boise. As was GSA's practice of the time, the local firm was to serve as the Architect of Record, but an architect of national prominence was also named as Consulting Architect - in this case, the office of Charles Luckman Associates based in Los Angeles, California. Charles F. Hummel was Partner-in-Charge locally and Richard Niblock represented Luckman's office.

Much public debate over the site selection for the new federal facility was documented in local newspapers. Decentralization of the downtown core was of great concern to the public and downtown businesses. Arguments were raised for siting the building, which would consolidate dispersed federal agencies and potentially benefit nearby businesses with an influx of federal employees, close to the city center and the Idaho State Capitol building. The first site GSA selected on Main Street between 2nd and 3rd was the site of the historic Federal Assay Office, completed in 1871 by the U.S. Department of the Treasury. The idea of demolishing the historic Federal Assay Office proved highly controversial among the public and was quickly abandoned. As no other centrally located sites of the scale required were feasible in the downtown core, readily available land at Fort Boise, then under the control of the Department of Veteran Affairs, was selected. This site, though not centrally located, was only a short distance from the capitol

⁸ Aerial photos of site show graded land in 1950s. Idaho State Archives, photo collections, accessed October 28, 2015.

⁹ Details related to design development and design intent were provided by the architect Charles F. Hummel as part of a narrative prepared for GSA's Image Master Plan (c.2000) and via phone interview (2015).

Federal Building and U.S. Courthouse
Name of Property

Ada Co., ID
County and State

building and with the advantages of a picturesque setting on a previously cleared plot of land already owned by the federal government.

Based on the GSA directives, design development proceeded at the Boise and Los Angeles offices from November 1961 through March 1962. Once GSA approved the diagrammatic design, the designers proceeded to the next stage of development. Design development continued through three rounds with submittals in July 1962, March 1963 and October 1964, before finally achieving a full set of construction documents submitted on December 28, 1964. Design development for the building occurred as the federal government was establishing the Guiding Principles. Architect Charles Hummel indicates in his written documentation of the design process that the ideas represented in the Guiding Principles and propagated by the Kennedy Administration were integral to the design process for the Boise Federal Building and U.S. Courthouse.

Contractor bids were sought in March of 1965 and the construction contract was awarded to Jacobsen Construction Company of Salt Lake City, Utah. Construction on the shell began in July of 1965. The interior partitioning was awarded as a separate contract to Jacobsen in the fall of 1966. Construction of the building was completed, after some extensions, in January of 1968 at a final cost of \$6,586,290.

Though the building was complete and federal agencies began moving in at the end of 1967, the parking and site landscaping remained unresolved and lacked funding. The parking design included the current paved areas west and north of the building, but the site did not allow for the full extent of parking required. Designers initially also proposed parking across N. 5th Street that required the removal of the Fort Boise Stone Guardhouse, entry columns, and mature trees. This idea was vetted and abandoned after public commentary identified the historic guardhouse as an important building to retain. To this day the full desired amount of parking for the property has never been realized. The parking lots were completed by late 1968. Landscaping of the grounds was not completed until 1969.

Design Intent and Philosophy¹⁰

President and Mrs. Kennedy's guidance and interest in the building and the emphasis on exemplary modern architecture made an impression on the Hummel/Luckman design team and reinforced their already established convictions regarding the importance of design excellence. The Hummel firm, then in its 65th year of practice in Idaho, had a solid reputation for outstanding design and professional service and the more recently established Luckman firm was famous because of Charles Luckman's reputation as a leader in America's modern architecture when, as a [p]resident of Lever Brothers, he directed the

¹⁰ Excerpts taken from a narrative prepared by architect Charles F. Hummel as part of GSA's Image Master Plan presentation (c.2000). A copy of this narrative was provided by Charles Hummel to the author of this nomination and has been provided to GSA's Regional Historic Preservation Officer for the regional records.

Federal Building and U.S. Courthouse
Name of Property

Ada Co., ID
County and State

construction of Lever House on New York's 5th Avenue - a building which got instant favorable notice from the architectural and critical community.

Lever House was one of the first true aluminum and glass curtain wall buildings in the post-World War II International Style. The design team, however, came to an early decision that this building's location and function required a different architectural expression - something more muscular and bolder. Both Charles Hummel and the Luckman staff at that time were impressed with the work of three great contemporary designers - Le Corbusier, Marcel Breuer, and Paul Rudolph. Common elements in their work include the use of exposed form-finished concrete, elevations of the building mass on pilotis, strong fenestration, the exposure of massive structural features and their integration as primary design elements.

In various ways, all of these aspects of structural expressionism were incorporated in the design development of the project and readily approved by GSA's Public Buildings Service.

With regard to design philosophy and intent, Charles Hummel provided the following insights:

On the west the site is adjacent to a public park with beautiful trees. On the east the VA grounds are open, and park-like and with views to the Boise foothills beyond. The design team's first response to this setting was to think of a structure on pilotis to maintain visual continuity between the park and the VA grounds. Since that was impractical the first siting design oriented the long direction of the building east and west to minimize interruption of the visual continuity between the two adjacent areas and to present the main building facade to Fort - the frontage street.

That siting was impractical because of the awkward parking and vehicular access which resulted from the relatively narrow east-west site distance. Thus, the long dimension of the building had to be aligned with the long north-south direction of the available site and to position the entrance of the building in a convenient relation to the parking area.

The design objective of maintaining the visual flow of the park setting still remained and was addressed by decreasing the two lower floor areas and extending the five upper floors out on 16 foot cantilevered beams resting on massive columns. The two lower floors were enclosed in glass curtain walls and the main floor areas were designed to be as open as possible to further promote the feeling that the mass of the building somehow "floats" over its base. The lower floor surface is further extended out into the site on a low granite podium which, in fact is a cover over the larger basement floor below.

The site landscaping is modest and consists mainly of small trees in the parking area planters. It was a design intention to have the building podium simply terminate at the line of the surrounding lawn and not have its vertical and horizontal planes interrupted by shrubbery...

Federal Building and U.S. Courthouse
Name of Property

Ada Co., ID
County and State

...Both the beauty of the site's setting and its physical limitations have had a positive influence on the building's design.

In various ways, all of these aspects of structural expressionism were incorporated in the design development of the project and readily approved by GSA's Public Buildings Service."

Materials and Systems¹¹

The Federal Building and U.S. Courthouse is very clean and clear in its materials, and systems were modern, thoughtful, and integrated to achieve this clarity. Architect Charles Hummel summarized the concept behind the material palette:

It was a design objective to use the least number of major exterior and interior materials which accounts for the fact that the exterior is basically white and natural concrete, gray glass and black granite, sand honed on its floor surface and carried from the podium into the main entrance lobby and hallways. Colorado walnut travertine and oak wood work comprise [sic] the rest of the major interior finish materials palette.

Charles Hummel also emphasized the influence the engineers had on the design of the building. They played a key role in shaping the design through their willingness to be innovative and seek solutions to support the overall design intent. Progressive ideas were pursued ranging from the structural design to the integration of interior mechanical and electrical systems, and to the selection of materials and product. The many cutting-edge modern systems and materials included in the design of the Federal Building and U.S. Courthouse are typical for Modernist buildings of the era and further testament to the influence of the Guiding Principles through the incorporation of contemporary innovation.

The system having the greatest impact on the design of the building is the structural system. Designed by Harry Mejdell, P.E., who later became Chief for Structural Design of CH2M-Hill, innovative solutions utilizing the most modern systems and materials were required to cantilever the upper five floors on post-tensioned concrete beams and massive columns. Two-way cantilever extensions were engineered to solve problems at the building's corners. Since the state-of-the-art design of the cantilever system was sensitive to differential settlement, much analysis went into the design of the foundation system. It was discovered that suitable bearing soils were thirty feet down and the most successful foundation system was determined to be steel point-bearing piles driven down to that soil.

To lighten the load on the foundation and beam systems, above the third-floor floors were constructed of cellular steel decking and lightweight concrete fill, walls framed in steel, and the exterior envelope composed of an assembly of architectural precast concrete window modules

¹¹ Details related to design development and design intent were provided by the architect Charles F. Hummel as part of a narrative prepared for GSA's Image Master Plan (c.2000) and via phone interview (2015).

Federal Building and U.S. Courthouse
Name of Property

Ada Co., ID
County and State

cast out of light weight concrete. Otto Buehner & Company of Utah, touted as the “Nation’s Best Known Pre-caster” by Concrete Products magazine in 1964, designed and built the unique precast window units using expanded shale aggregate concrete and white Portland cement. At the time, Otto Buehner & Co. was the only precast contractor in the country with the capacity and resources to produce precast concrete units for large scale buildings such as the Federal Building and U.S. Courthouse.¹² The company was a leader in pioneering the Mo-Sai and Schokbeton manufacturing methods¹³ and ascended to leadership roles within the Mo-Sai Institute, Schokbeton Council, and Prestressed Concrete Institute. The company provided architectural precast concrete units for notable buildings including the Pan Am Building in New York (1963), the Pacific Science Center in Seattle (1962), the Hilton Hotel in Denver (1960), the Prudential Building in Los Angeles (1949), and the Latter-Day Saints Temple in Idaho Falls (1941), to name a few.

Extensive consideration was also given to the placement of mechanical and electrical systems throughout the building. An innovative newly-patented suspended ceiling based on the 5’x5’ building module was used to integrate the systems including continuous light troffers and linear air diffusers and returns concealed in the grid bars. The system also coordinated with the movable office partition system allowing for maximum flexibility of floor plan layout.

In the United States, early versions of suspended ceilings were first developed in the 1920s, usually consisting of a metal anchorage system suspending sheets of plaster on flat or shaped metal lath. Patent records show innovations over subsequent decades centered around refinements in anchorage, ease of installation, and materials. The 1940s and 1950s saw development of the ceiling grid concept, new materials, and new suspension systems. Modern ceiling manufacturers credit the invention of the "modern" suspended ceiling to Donald Brown of Westlake, Ohio, who was granted a patent for his design of an "Accessible Suspended Ceiling Construction" in 1961. Brown's invention allowed access above the ceiling at any predetermined location, where previous suspended systems with interlocking panels required dismantling from the edge to the location requiring access. A boom of patents focused on integrating lighting and mechanical systems into the suspended ceiling grid occurred in the late 1950s and early 1960s¹⁴. A patent for a "Combination Diffuser and False Ceiling Suspension System" was filed by E.F. Averill in 1966. Averill's invention is described as "improvements in combination diffuser and false ceiling suspension systems wherein elongated slot diffusers are employed for distribution of air and also as the elongated supporting members for supporting panels or other elements of a suspended ceiling." Patent drawings show the same newly emerging system as was installed in

¹² Pyburn, Jack. "Mid-Century Architectural Precasting in the Western States." Presentation at Preserving the Recent Past 3 conference, Los Angeles, California, March 13-16, 2019.

¹³ Mo-Sai is a process of producing precast concrete panels with an exposed aggregate finish, patented in 1940. Schokbeton is a process of making high density precast concrete by shocking the mass through vibration during the pouring, patented in 1934.

¹⁴ Patent history accessed through Google Patents search of "suspended ceilings" and "suspended ceiling diffusers", <https://patents.google.com/>

Federal Building and U.S. Courthouse
Name of Property

Ada Co., ID
County and State

the Federal Building and U.S. Courthouse (see Figure 14) within a year of the patent being filed¹⁵.

The mechanical plant design was originally for an innovative energy-conserving system based on an electrically-driven water-to-water-to air heat pump system. However, the system was changed to a more conventional natural gas heat and gas-absorption chiller, presumably due to budget considerations, prior to bid. In 1999-2000 the system underwent a geothermal retrofit.

An additional system of note is the original window washing apparatus located on the roof. An automated mobile swing stage is stored in the penthouse. The swing stage machinery moves outside the penthouse through a roll-up door and along the perimeter of the roof on a pair of rails. The swing stage extends from the main equipment to hang over the edge of the roof. The stage is five bays wide and is held in line with the bays as it descends by outriggers that extend into the vertical gap between precast window modules (Figure 15).

The Modern Movement

In the United States, Modernism began in the 1920s and continued through the 1970s, overlapping lingering styles of the past and Post-Modern ideologies of the 1960s through the 1990s. The early wave of Modernism was mainly focused around the International Style and began to decline toward the 1950s. The Late-Modern period roughly covers the 1950s through the 1970s and includes many sub-styles, the most commonly accepted included Formalism, Brutalism, Expressionism and the International style.

In general, Modernism expressed advances in technology, materials, and building methods. Common differences from ideologies of the past included tenets such as minimizing interior lobbies by creating exterior plazas that served as gateways and gathering spaces, employing transparent building materials to bridge between the exterior and interior, and using building components that were pre-fabricated or constructed on site to maximize economy during construction. At interiors, offices were planned to maximize flexibility with movable partition walls, open office floor plans, and innovative electrical and mechanical systems that could adapt to change. Design theory also sought to emphasize social equity and democratic values such as providing equal access, equal workspace, and avoiding the displacement of people. The Federal Building and U.S. Courthouse embraces all of these tenets.

Of the sub-styles, the Federal Building and U.S. Courthouse can best be described as New Formalism. While embracing the broad ideas of Modernism, New Formalism rejected the idea of turning away completely from the past, reintroducing classical themes such as scale and proportion, symmetry, and columns, entablatures, and colonnades, while continuing to employ

¹⁵ U.S. Patent 3,440,947: Combination Diffuser and False Ceiling Suspension System, patented April 29, 1969. Accessed February 6, 2019, from <https://patents.google.com/patent/US3440947A/en?q=suspended+ceiling&q=diffuser&oq=suspended+ceiling+diffuser>

Federal Building and U.S. Courthouse
Name of Property

Ada Co., ID
County and State

new innovations in concrete technology. In the United States, New Formalism was applied predominantly to institutions and public buildings.¹⁶

The Federal Building and U.S. Courthouse reflects the massing and monumentality, symmetry, and simplified classical elements of the New Formalism style in its overall design, organization of elevations, and employment of massive pilotis and beams. The recessed pedestal level creates a modern colonnade encircling the building.

COMPARATIVE ANALYSIS

Federal Context

GSA undertook hundreds of projects in the 1960s and early 1970s seeking to establish modern federal facilities across the country. Of these only a few fall under the New Formalism sub-style of Modernism. GSA provided a list of federal buildings constructed in the late 1960s and categorized as New Formalism. Of the buildings on that list, the following were comparable in scale and design: the Clifford Davis-Odell Horton Federal Building (1963) in Memphis, Tennessee, the J.J. Pickle Federal Building (1965) in Austin, Texas, the Dick Cheney Federal Building (1970) in Casper, Wyoming, the Joseph C. O'Mahoney Federal Center (1965) in Cheyenne, Wyoming, the Hurff A. Saunders Federal Building (1966) in Juneau, Alaska, the Wallace Bennett Federal Building (1965) in Salt Lake City, Utah, the Peter W. Rodino, Jr. Federal Office Building (1967) in Newark, New Jersey, and the Charles E. Bennett Federal Building (1966) in Jacksonville, Florida (see Figure 17 for images).

These buildings have in common with the Federal Building and U.S. Courthouse in Boise their massing as a multi-story rectangular mass over a two-story recessed pedestal, a modular elevation composition, and similar materials that include architectural precast concrete window units. Two of these buildings have been fully reskinned in the past two decades and no longer retain integrity. The Federal Building and U.S. Courthouse in Boise is representative of what was being developed by GSA at the time but does not appear to rise to the national level of significance within the nationwide GSA portfolio.

State and Local Context

A search of National Register properties in Idaho found no similar modern buildings listed in Boise or the state. (Nearby in Washington state, the Richland Federal Building and U.S. Courthouse was constructed in 1965 and is of the New Formalism style with similar interior features, but the interpretation of the style and scale of the building is vastly different from the Federal Building and U.S. Courthouse in Boise.) A search of Boise inventories, architecture and modern preservation listings, as well as a windshield survey of Boise and consultation with the Idaho State Historic Preservation Office, yielded the following three buildings for comparative analysis: Boise Plaza (1971), Idaho Supreme Court (c.1970), and Idaho Power (c.1992) (Figure 18).

¹⁶ Docomomo WeWa website (2015), *Modern Styles*. Accessed November 30, 2015, from http://www.docomomo-wewa.org/style_gallery.php.

Federal Building and U.S. Courthouse
Name of Property

Ada Co., ID
County and State

1. BOISE PLAZA (FORMERLY BOISE CASCADE) -1111 W. JEFFERSON - 1971. The Boise Cascade headquarters building was designed by the internationally renowned architecture firm of Skidmore, Owings, & Merrill (SOM). The building was remodeled in 2006 after ownership shifted to Rafanelli and Nahas. The building also became known as Boise Plaza.
2. IDAHO SUPREME COURT - 450 W. STATE ST. - C.1970. The building was designed by Victor Hosford of the local architecture firm Dropping Kelly Hosford and LaMarche and constructed by the Skyline Construction Company.
3. IDAHO POWER - 1220 IDAHO ST. - C.1992. In 1990, construction for the new Idaho Power headquarters broke ground. Constructed on potentially the largest single slab of concrete in Boise, the new building now towers above its contemporary predecessors.

These buildings all post-date the Federal Building and U.S. Courthouse, significantly in the case of the Idaho Power building, and share some commonalities, but are ultimately quite different in their style, materials, and application of modernist tenets. There are no known buildings in Boise or the State of Idaho that are comparable in size, quality of design, or representation of Modern architecture. The Federal Building and U.S. Courthouse is the best example of Modernism and specifically the sub-style New Formalism, as well as the primary federal presence, in the City of Boise and the State of Idaho.

ORIGINAL ARCHITECTS

As Modernism was embraced from the 1950s through 1970s, the Federal Government did also award commissions to internationally and nationally acclaimed architects - such as Skidmore, Owings & Merrill, Ludwig Mies van der Rohe, Philip Johnson, I.M. Pei, Henry Cobb, Walter Gropius and Eero Saarinen - in larger cities, but locally recognized architects in smaller cities and towns. Often local architects were paired with more widely known architects on a given project as well.

In 1961, GSA awarded a professional services contract for the Federal Building and U.S. Courthouse in Boise, Idaho, to the firm of Hummel Hummel & Jones of Boise (shortly thereafter renamed Hummel Hummel Jones & Shawver). Charles Luckman Associates of Los Angeles, California was named as consulting architect on the project. Charles F. Hummel, grandson of firm founder Charles Hummel, was the Partner-in-Charge of the project from Boise and Richard Niblock represented the Luckman office. The Federal Building and U.S. Courthouse aligns with the design innovation and style exploration that characterized Luckman's office at the time, including the New Formalism style Forum in Inglewood, California, as well as the Theme Building at Los Angeles International Airport and Madison Square Garden Center in New York City. Charles Hummel was recognized in 2012 as an Idaho Modern Master by Idaho Modern, an advocacy committee of the non-profit organization Preservation Idaho and his Federal Building and U.S. Courthouse is considered by the local architecture community, Idaho Modern, and the

Federal Building and U.S. Courthouse
Name of Property

Ada Co., ID
County and State

State Historic Preservation Office to be an exemplary work. Thus, this building is an important example of this master architect's work in Idaho.¹⁷

Hummel Hummel Jones & Shawver

The contemporary Boise-based firm, Hummel Architects, is the descendent of the firm Tourtellotte & Hummel formed by Idaho Master Architects John E. Tourtellotte and Charles Hummel in 1910. Charles Hummel's sons, Frederick (Fritz) and Frank, joined the firm in 1909 and 1913 and continued through WWI, Tourtellotte's retirement in 1929, and the death of their father in 1939. The Hummel brothers kept the firm alive through WWII until a full work schedule resumed in 1945 and the partnership was enlarged to include Jedd Jones, III, who had been with the firm before the war. With this addition the firm name changed to Hummel Hummel & Jones in 1946. Fritz, Frank and Jedd maintained a successful partnership for 31 years moving into the mid-century with local, state, and federal agencies as major clients and a diverse portfolio of project types ranging from offices, university facilities, and Air Force bases to private banks, churches, and stores.

The 1940s also saw the introduction of Chester Shawver and Fritz's son Charles F. Hummel to the firm. After Frank Hummel's unexpected death in 1962, Chester and Charles became partners with Fritz and Jedd. It was at this juncture in the firm's history that the Boise Federal Building and U.S. Courthouse was awarded, and Charles F. Hummel, grandson of founder Charles Hummel, was named Partner-in-Charge of the project.

Charles remained a partner with the firm after his father's death in 1978, through many subsequent changes in partnership and firm name, until his retirement in 1999. After several partnership and name changes, as well as a merger with Boise firm Dropping, Kelly and LaMarche in 1984, the decision was made in 1997 to permanently change the firm name to Hummel Architects, recognizing over a century of continuous name association with the Hummel family. Charles F. Hummel was named the first Idaho Modern Master by Idaho Modern in 2012.

Charles Luckman Associates

Charles Luckman was a successful businessman turned modern master of architecture. Though trained as an architect, graduating during the Great Depression he found himself employed as a draftsman in the advertising department of the Colgate-Palmolive-Peet Company. Success in this position led to an offer to become sales manager of the Pepsodent Company in 1935. In 1937, Luckman was featured on the cover of Time Magazine as the "Boy Wonder" of American industry. At the young age of 30 Luckman became president of Lever Brothers. While in this position Luckman heavily influenced the plans for Lever Brothers' innovative New York skyscraper, Lever House, designed by prominent firm Skidmore Owings & Merrill in 1952. Before completion of Lever House, Luckman resigned from Lever Brothers and relocated to Los

¹⁷ "Idaho Modern." *Preservation Idaho*, www.preservationidaho.org/idaho-modern/.

Federal Building and U.S. Courthouse
Name of Property

Ada Co., ID
County and State

Angeles to start his own architecture practice - Luckman Partnership. Luckman quickly formed a partnership with Los Angeles architect William Pereira, establishing their firm - Pereira & Luckman. The firm specialized in office buildings, airports, and Air Force bases. Luckman was embraced by corporate executives, government officials, and civic leaders for his pragmatic views of architecture. Luckman was quoted saying “I am firm in my belief that architecture is a business and not an art,” as well as commenting “We might recommend a building with three medium-size wings, instead of one big one, so that three people could give the wings and have them named after them.”¹⁸ Pereira and Luckman parted ways in 1959 and Charles Luckman Associates was formed. The firm is best known for the Prudential Tower (1960-63) in Boston, the Theme Building at Los Angeles International Airport (1961), the NASA Manned Spacecraft Center (1962-63) in Houston, the Forum in Inglewood, California (1967), the new Madison Square Garden (1968) in New York City, and Aon Center (1972) in Los Angeles. Luckman was unfortunately linked to the demolition of Penn Station, the site of his new Madison Square Garden design and one of the catalysts for the national historic preservation movement. Luckman merged his firm in 1968 with the Ogden Corporation, a major real estate developer, and he subsequently became president of its subsidiary, Ogden Development. This merger lasted only until 1973. Charles Luckman retired from Charles Luckman Associates in 1977 and the firm reorganized into the Luckman Partnership headed by his son James Luckman. Charles Luckman died in 1999 in Los Angeles at the age of 89.

Little is known about Richard Niblock, identified as the project representative for Charles Luckman Associates for the Federal Building and U.S. Courthouse.

BUILDING OCCUPANTS

The Federal Building and U.S. Courthouse was constructed to consolidate federal agencies, including the U.S. General Services Administration, U.S. Internal Revenue Service, U.S. District Court, and U.S. Court of Appeals, U.S. Marshals, and several other federal bureaus and departments, located around town in separate leased spaces. It included roughly two dozen agencies and 1,285 employees. Many of those agencies still occupy the building including those mentioned above.

The 1967 Federal Building and U.S. Courthouse relocated the courts from the building constructed in 1905 to serve the U.S. District Court of Idaho, which met in Boise beginning in 1890, and which was extended in 1930. The Neoclassical style building is located at 750 West Bannock Street and is currently occupied by the U.S. Postal Service.

On December 12, 2001, President George W. Bush signed a law designating this building the James A. McClure Federal Building and United States Courthouse.¹⁹ James A. McClure was a

¹⁸ Muschamp, Herbert. “Charles Luckman, Architect Who Designed the Penn Station Replacement, Dies at 89.” *New York Times Magazine*, 28 January 1999.

¹⁹ “House Report 107-301.” *Code of Federal Regulations | Govinfo*. Accessed February 7, 2019, from www.govinfo.gov/content/pkg/CRPT-107hrpt301/html/CRPT-107hrpt301.htm.

Federal Building and U.S. Courthouse
Name of Property

Ada Co., ID
County and State

U.S. Senator from Idaho (1973-1991), a U.S. Congressman from the 1st District of Idaho (1967-1973), and an Idaho State Senator (1961-1966).

EVALUATION OF SIGNIFICANCE

Under Criterion A, the Federal Building and U.S. Courthouse reflects the goals of the “Guiding Principles for Federal Architecture,” developed and published during the design development phase for the building. Written documentation of the design process by the local architect of record, Charles F. Hummel, confirms that the ideas set forth in the Guiding Principles and promoted by the Kennedy Administration directly influenced the design process.

Construction of the building, bringing federal agencies scattered throughout Boise into one significant, iconic structure, provided a unified Federal presence in Boise and an architectural focal point north of the State Capitol. “[It demonstrated] Boise finally achieved the prestige and population needed to obtain a federal courthouse.”²⁰

Under Criterion C, the Federal Building and U.S. Courthouse was and still is the only known representation of 1960's modernism of this scale, style, and quality in the City of Boise and the only federally-owned building of its type in the State of Idaho.

In addition to embodying modern design values, the Federal Building and U.S. Courthouse is considered by state preservation organizations to be a formative work in the portfolio of prominent Idaho architect Charles F. Hummel - named Idaho's first Modern Master in 2012 by Idaho Modern.

Contributing buildings on the site include the Federal Building and U.S. Courthouse, including the surrounding podium, and the original mechanical enclosure structure located to the north of the building in the parking lot. The contemporary west entrance plaza and the small vehicular entry guard station are non-contributing.

²⁰ Boise Architecture Project website. *Building Boise videos*. Accessed November 24, 2015, from <http://www.boisearchitecture.org/videos.php>

Federal Building and U.S. Courthouse
Name of Property

Ada Co., ID
County and State

9. Major Bibliographical References

Bibliography (Cite the books, articles, and other sources used in preparing this form.)

PERIODICALS

Muschamp, Herbert. "Charles Luckman, Architect Who Designed the Penn Station Replacement, Dies at 89." *New York Times Magazine*, 28 January 1999.

The Idaho Daily Statesman (Boise). 21 February 1960; 5 October - 31 December 1961; 7 September - 30 December 1966; 2 May - 26 November 1967; 16 June - 9 December 1968.

PUBLICATIONS

Brown, J. Carter, ed., *Federal Buildings in Context: The Role of Design Review*, Washington: National Gallery of Art, and Hanover, N.H.: University Press of New England, 1995.

Craig, Lois, et al., *The Federal Presence: Architecture, Politics, and Symbols in United States Government Buildings*, Cambridge: MIT Press, 1978.

Hummel, Charles, Tim Woodward, and Jeanne Huff, *Quintessential Boise: An Architectural Journey*, Boise State University - College of Social Sciences and Public Affairs, 2010.

Robinson & Associates, *Growth, Efficiency, and Modernism: GSA Buildings of the 1950s, 60, and 70s*, Washington: Center for Historic Buildings, Office of the Chief Architect, U.S. General Services Administration, 2003.

Schwantes, Carlos A., *In Mountain Shadows: A History of Idaho*, Lincoln: University of Nebraska Press, 1991.

U.S. Department of the Interior, National Park Service, Cultural Resources. *National Register Bulletin: How to Apply the National Register Criteria*. 1998.

U.S. Department of the Interior, National Park Service, Technical Preservation Services. *Twentieth-Century Building Materials - History and Conservation*. Getty Conservation Institute, 2014.

Walton, Thomas, *Architecture of the Great Society: Assessing the GSA Portfolio of buildings during the 1960s and 70s*, Washington: Center for Historic Buildings, Office of the Chief Architect, U.S. General Services Administration, 2001.

Federal Building and U.S. Courthouse
Name of Property

Ada Co., ID
County and State

ONLINE SOURCES

Boise Architecture Project website. *Building Boise videos*. Accessed November 24, 2015, from <http://www.boisearchitecture.org/videos.php>

Boise City Department of Arts & History website. *Early Lumber Companies of Boise*. Accessed December 2, 2015, from <http://www.boiseartsandhistory.org/history/research-collection/enterprise/business-industry/early-lumber-companies-of-boise/>.

"Boise's Historic Districts." *Transportation – City of Boise*. Accessed December 10, 2018. pds.cityofboise.org/planning/hp/districtsmap/.

Docomomo WeWa website (2015). *Modern Styles*. Accessed November 30, 2015, from http://www.docomomo-wewa.org/styles_gallery.php.

Great Buildings website. *American Architecture - Twentieth Century - 1960-1969*. Accessed January 19, 2016, from http://www.greatbuildings.com/types/usa/usa_1960-1969.html.

Hummel Architects website (2015). Accessed November 24, 2015, from <http://hummelarch.com/about/#hummel>.

Idaho Modern website (2015). Accessed November 30, 2015, from <http://idahomodern.org/>

Wells, Merle. "National Register of Historic Places Nomination Form - Fort Boise (72000433)." *National Park Service*, National Archives and Records Administration, 9 Nov. 1972. Accessed January 14, 2016 from catalog.archives.gov/id/84248868.

National Park Service website. *National Register of Historic Places Focus database*. Accessed January 14, 2016, from <http://www.nps.gov/nr/research/>.

Recent Past Preservation Network website. *Recent Past Bibliography*. Accessed November 30, 2015, from <http://recentpast.org/recent-past-bibliography/>.

U.S. Patent 3,440,947: Combination Diffuser and False Ceiling Suspension System, patented April 29, 1969. Accessed February 6, 2019, from <https://patents.google.com/patent/US3440947A/en?q=suspended+ceiling&q=diffuser&oq=suspended+ceiling+diffuser>

OTHER SOURCES

ASM Affiliates. *Archaeological Monitoring Report for Perimeter Security Upgrades Measures at the McClure Federal Building, Boise, Idaho*, December 2015.

U.S. General Services Administration. *Pre-occupancy Brochure - Federal Building, U.S. Court House, Boise, Idaho*. 1967.

Federal Building and U.S. Courthouse
Name of Property

Ada Co., ID
County and State

U.S. General Services Administration. Construction Documents and Maintenance Records dating from 1965 to present. Accessed October 2015 - March 2016.

Hennebery Eddy Architects. "Building Preservation Plan: James A. McClure Federal Building." February 2017.

Hennebery Eddy Architects. " Determination of Eligibility for Inclusion in the National Register of Historic Places: James A. McClure Federal Building." March 2016.

Hummel, Charles F., FAIA. Phone interview by author, 3 December 2015, Portland.

Hummel, Charles F. "Image Master Plan for Federal Building & US Courthouse, Boise, Idaho." Washington, D.C.: U.S. General Services Administration, c.2000.

Idaho State Archives, maps and photo collections. Accessed October 28, 2015.

Previous documentation on file (NPS):

- preliminary determination of individual listing (36 CFR 67) has been requested
- previously listed in the National Register
- previously determined eligible by the National Register
- designated a National Historic Landmark
- recorded by Historic American Buildings Survey # _____
- recorded by Historic American Engineering Record # _____
- recorded by Historic American Landscape Survey # _____

Primary location of additional data:

- State Historic Preservation Office
 - Other State agency
 - Federal agency
 - Local government
 - University
 - Other
- Name of repository: _____

Historic Resources Survey Number (if assigned): _____

Federal Building and U.S. Courthouse
Name of Property

Ada Co., ID
County and State

10. Geographical Data

Acreeage of Property 8.548

Use either the UTM system or latitude/longitude coordinates

Latitude/Longitude Coordinates (decimal degrees)

Datum if other than WGS84: _____

(enter coordinates to 6 decimal places)

- | | |
|--------------|------------|
| 1. Latitude: | Longitude: |
| 2. | |
| 3. Latitude: | Longitude: |
| 4. Latitude: | Longitude: |
| 5. Latitude: | Longitude: |

Or

UTM References

Datum (indicated on USGS map):

NAD 1927 or NAD 1983

- | | | |
|-------------|-----------------|-------------------|
| 1. Zone: 11 | Easting: 565024 | Northing: 4830086 |
| 2. Zone: | Easting: | Northing: |
| 3. Zone: | Easting: | Northing: |
| 4. Zone: | Easting : | Northing: |

Verbal Boundary Description (Describe the boundaries of the property.)

The Federal Building and U.S. Courthouse is located in Boise, Idaho in Ada County on parcel S1003449400 (property description: PAR #9400 OF SE4 SEC 03 3N 2E). The site is bound by W. Fort Street to the south, N. 5th Street to the east, Fort Boise/VA Medical Center to the east and north, and Memorial Park to the west. The boundary was determined by the property lines.

Federal Building and U.S. Courthouse
Name of Property

Ada Co., ID
County and State

Boundary Justification (Explain why the boundaries were selected.)

The boundary represents the original property boundary and includes the Federal Building and U.S. Courthouse, the entry plaza, vehicular entry security guard station, parking lots, basement parking access, mechanical enclosure, walkways and landscaping.

11. Form Prepared By

name/title: Carin Carlson, Associate/Historical Architect
organization: Hennebery Eddy Architects
street & number: 921 SW Washington Street, Suite 250
city or town: Portland state: OR zip code: 97205
e-mail ccarlson@henneberyeddy.com
telephone: 503-227-4860
date: July 15, 2019

Additional Documentation

Submit the following items with the completed form:

- **Maps:** A **USGS map** or equivalent (7.5 or 15 minute series) indicating the property's location.
- **Sketch map** for historic districts and properties having large acreage or numerous resources. Key all photographs to this map.
- **Additional items:** (Check with the SHPO, TPO, or FPO for any additional items.)

Federal Building and U.S. Courthouse
Name of Property

Ada Co., ID
County and State

Photographs

Submit clear and descriptive photographs. The size of each image must be 1600x1200 pixels (minimum), 3000x2000 preferred, at 300 ppi (pixels per inch) or larger. Key all photographs to the sketch map. Each photograph must be numbered and that number must correspond to the photograph number on the photo log. For simplicity, the name of the photographer, photo date, etc. may be listed once on the photograph log and doesn't need to be labeled on every photograph.

Photo Log

Name of Property: Federal Building and U.S. Courthouse

City or Vicinity: Boise

County: Ada State: Idaho

Photographer: David Wark

Date Photographed: October 26-28, 2015 *

(*GSA verifies that the photographs continue to reflect the current condition and status of the property.)

Description of Photograph(s) and number, include description of view indicating direction of camera:

- Photo 1 of 26: ID_AdaCounty_FederalBuildingandU.S.Courthouse_0001
Primary/west elevation showing entry addition, west parking lot, and landscaping, camera facing southeast.
- Photo 2 of 26: ID_AdaCounty_FederalBuildingandU.S.Courthouse_0002
Primary/west elevation showing entry addition with vehicular entry guard booth in foreground, camera facing northeast.
- Photo 3 of 26: ID_AdaCounty_FederalBuildingandU.S.Courthouse_0003
Primary/west entrance showing 2004 First Impressions entry addition and 2015 plaza improvements, camera facing east.
- Photo 4 of 26: ID_AdaCounty_FederalBuildingandU.S.Courthouse_0004
South elevation, camera facing north.
- Photo 5 of 26: ID_AdaCounty_FederalBuildingandU.S.Courthouse_0005
East elevation, view from south edge of Fort Boise parade grounds with camera facing west.

Federal Building and U.S. Courthouse
Name of Property

Ada Co., ID
County and State

- Photo 6 of 26: ID_AdaCounty_FederalBuildingandU.S.Courthouse_0006
North elevation and parking lot, camera facing southeast.
- Photo 7 of 26: ID_AdaCounty_FederalBuildingandU.S.Courthouse_0007
Vehicular access ramp to secure basement level parking below podium,
camera facing southwest.
- Photo 8 of 26: ID_AdaCounty_FederalBuildingandU.S.Courthouse_0008
Southeast building corner showing south landscape area, site walls, and
Fort Boise stone guard house located between the property line and N. 5th
Street, camera facing northwest.
- Photo 9 of 26: ID_AdaCounty_FederalBuildingandU.S.Courthouse_0009
Mechanical enclosure in north parking lot, camera facing southwest.
- Photo 10 of 26: ID_AdaCounty_FederalBuildingandU.S.Courthouse_0010
Granite corner stone at southwest corner of podium, camera facing east.
- Photo 11 of 26: ID_AdaCounty_FederalBuildingandU.S.Courthouse_0011
First floor west lobby interior, camera facing east looking through elevator
lobby to east lobby and beyond to Fort Boise parade ground.
- Photo 12 of 26: ID_AdaCounty_FederalBuildingandU.S.Courthouse_0012
2004 west entry addition lobby, camera looking east toward historic west
lobby and showing formerly exterior pilotis and two bays where original
entry and curtain wall were removed.
- Photo 13 of 26: ID_AdaCounty_FederalBuildingandU.S.Courthouse_0013
Typical first floor corridor interior, camera facing south.
- Photo 14 of 26: ID_AdaCounty_FederalBuildingandU.S.Courthouse_0014
Second floor elevator lobby interior, camera facing west showing glazed
wall looking into west entry addition lobby.
- Photo 15 of 26: ID_AdaCounty_FederalBuildingandU.S.Courthouse_0015
Second floor tenant space interior, camera facing west.
- Photo 16 of 26: ID_AdaCounty_FederalBuildingandU.S.Courthouse_0016
Typical second floor corridor interior, camera facing north.
- Photo 17 of 26: ID_AdaCounty_FederalBuildingandU.S.Courthouse_0017
Typical elevator lobby interior (third floor shown), camera facing west.
- Photo 18 of 26: ID_AdaCounty_FederalBuildingandU.S.Courthouse_0018

Federal Building and U.S. Courthouse
Name of Property

Ada Co., ID
County and State

Typical upper floor corridor interior (third floor), camera facing south.

Photo 19 of 26: ID_AdaCounty_FederalBuildingandU.S.Courthouse_0019
Typical open office interior (third floor shown), camera facing south.

Photo 20 of 26: ID_AdaCounty_FederalBuildingandU.S.Courthouse_0020
Typical original public restroom interior finishes (Men's restroom shown).

Photo 21 of 26: ID_AdaCounty_FederalBuildingandU.S.Courthouse_0021
Sixth floor elevator lobby original interior (original courtroom floor),
camera facing east.

Photo 22 of 26: ID_AdaCounty_FederalBuildingandU.S.Courthouse_0022
Sixth floor court waiting area original interior, camera facing south.

Photo 23 of 26: ID_AdaCounty_FederalBuildingandU.S.Courthouse_0023
Sixth floor courtroom showing original volume and remodeled interior
finishes, camera facing east.

Photo 24 of 26: ID_AdaCounty_FederalBuildingandU.S.Courthouse_0024
dded sixth floor courtroom showing wood paneled interior finishes.

Photo 25 of 26: ID_AdaCounty_FederalBuildingandU.S.Courthouse_0025
Fifth floor elevator lobby remodeled in conjunction with addition of
courtrooms at fifth floor.

Photo 26 of 26: ID_AdaCounty_FederalBuildingandU.S.Courthouse_0026
Fifth floor courtroom addition.

Paperwork Reduction Act Statement: This information is being collected for applications to the National Register of Historic Places to nominate properties for listing or determine eligibility for listing, to list properties, and to amend existing listings. Response to this request is required to obtain a benefit in accordance with the National Historic Preservation Act, as amended (16 U.S.C.460 et seq.).

Estimated Burden Statement: Public reporting burden for this form is estimated to average 100 hours per response including time for reviewing instructions, gathering and maintaining data, and completing and reviewing the form. Direct comments regarding this burden estimate or any aspect of this form to the Office of Planning and Performance Management, U.S. Dept. of the Interior, 1849 C. Street, NW, Washington, DC.

United States Department of the Interior
 National Park Service

National Register of Historic Places
Continuation Sheet

Federal Building and U.S. Courthouse
Name of Property
Ada Co., ID
County and State
Name of multiple listing (if applicable)

Section number Additional Documentation Page 37

List of Figures

(Resize, compact, and paste images of maps and historic documents in this section. Place captions, with figure numbers above each image. Orient maps so that north is at the top of the page, all documents should be inserted with the top toward the top of the page.)

- Figure 1:** Vicinity map
- Figure 2:** USGS topographic map
- Figure 3:** Boundary map
- Figure 4:** Current site plan sketch and exterior photo key
- Figure 5:** Historic Drawing, first floor lobby perspective and partial plan, 1969
- Figure 6:** Historic Image, original west stair, podium, and first floor entry configuration, 1970
- Figure 7:** Otto Buehner & Company advertisement, 1963
- Figure 8:** Completed building, c.1969
- Figure 9:** Federal Building and U.S. Courthouse rendering, 1967
- Figure 10:** Construction photo, 1965
- Figure 11:** Construction of upper floor systems, 1966
- Figure 12:** Installation of window modules, 1966
- Figure 13:** Concrete window module before installation, 1966
- Figure 14:** Historic Image, installation of suspended ceiling and mechanical diffusers, 1967 (left); Patent 3,440,947 for Combination Diffuser and False Ceiling Suspension Systems, filed September 19, 1966 (right).
- Figure 15:** Historic Image, roof top window washing scaffold system, 1967 (GSA Archives)
- Figure 16:** West elevation, prior to 2004.
- Figure 17:** Comparative analysis: federal buildings:
- Figure 18:** Comparative analysis: State of Idaho and City of Boise:

United States Department of the Interior
National Park Service

National Register of Historic Places
Continuation Sheet

Federal Building and U.S. Courthouse
Name of Property
Ada Co., ID
County and State
Name of multiple listing (if applicable)

Section number Additional Documentation

Page 38

Figure 1: Vicinity map (Google Earth)

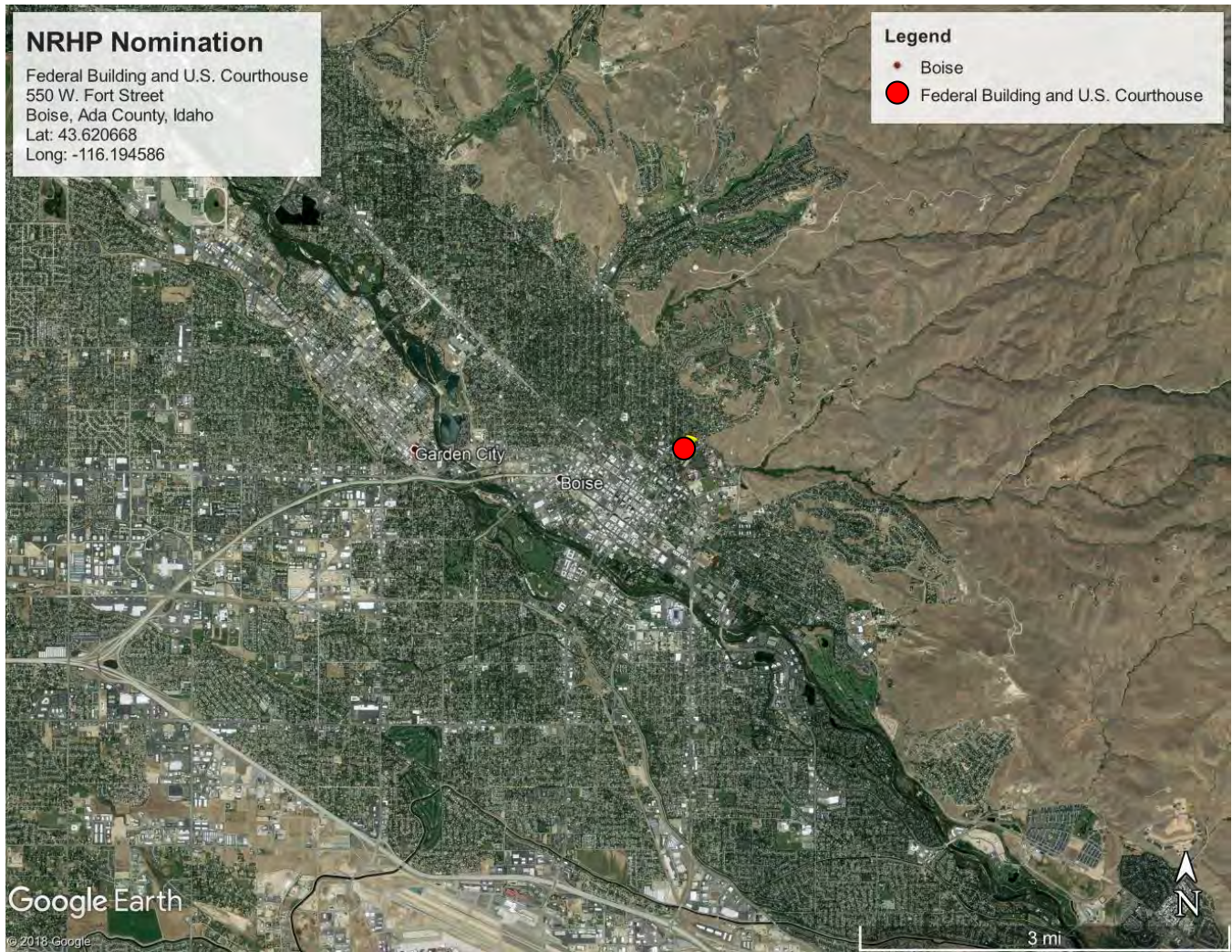

United States Department of the Interior
National Park Service

National Register of Historic Places
Continuation Sheet

Federal Building and U.S. Courthouse
Name of Property
Ada Co., ID
County and State
Name of multiple listing (if applicable)

Section number Additional Documentation Page 39

Figure 2: USGS topographic map

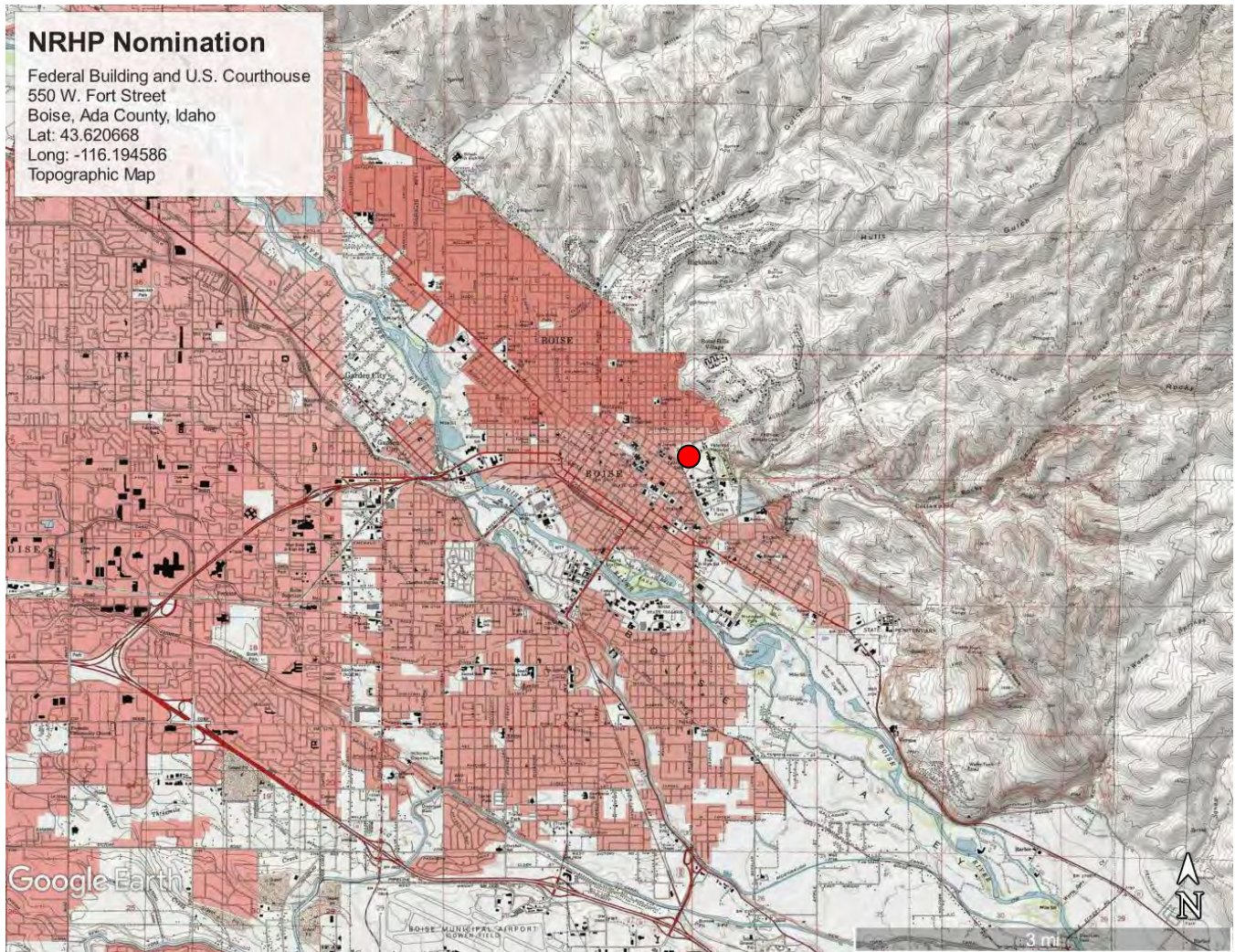

United States Department of the Interior
National Park Service

National Register of Historic Places
Continuation Sheet

Federal Building and U.S. Courthouse

Name of Property

Ada Co., ID

County and State

Name of multiple listing (if applicable)

Section number Additional Documentation

Page 40

Figure 3: Boundary map (Google Earth)

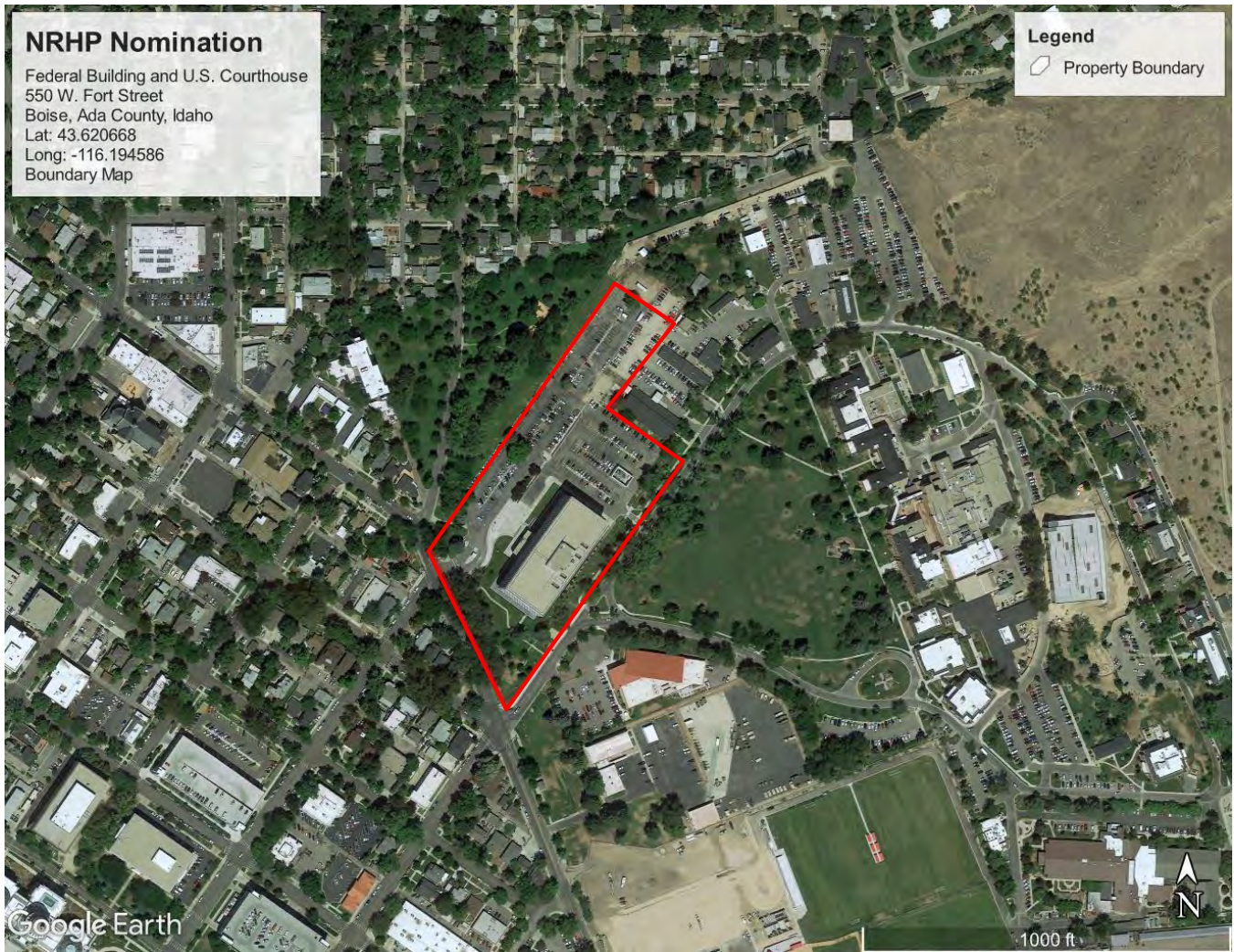

United States Department of the Interior
National Park Service

National Register of Historic Places
Continuation Sheet

Federal Building and U.S. Courthouse
Name of Property
Ada Co., ID
County and State
Name of multiple listing (if applicable)

Section number Additional Documentation Page 41

Figure 4: Current site plan sketch and exterior photo key (Hennebery Eddy Architects, 2016)

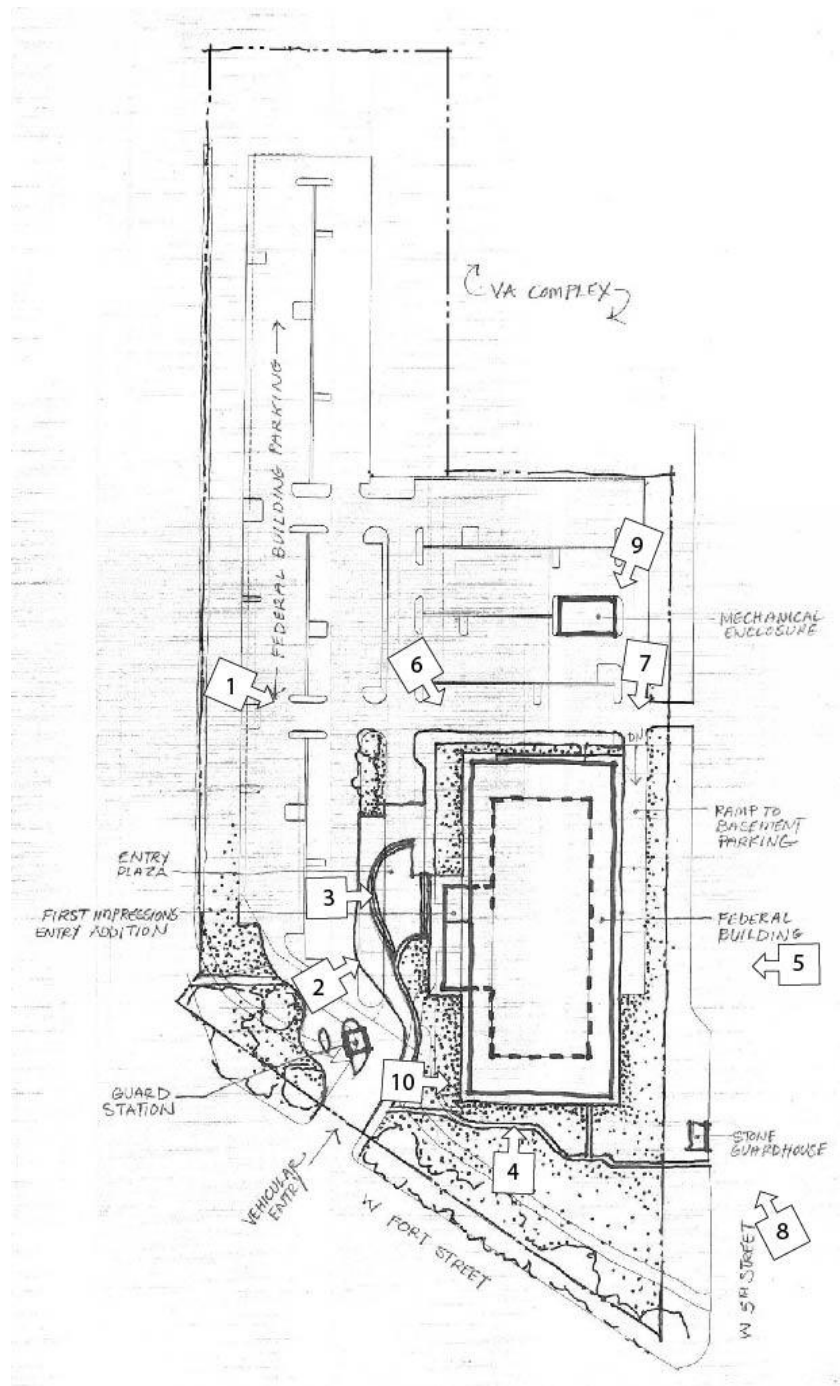

United States Department of the Interior
National Park Service

National Register of Historic Places
Continuation Sheet

Federal Building and U.S. Courthouse

Name of Property

Ada Co., ID

County and State

Name of multiple listing (if applicable)

Section number Additional Documentation

Page 42

Figure 5: Historic Drawing, First floor lobby perspective and partial plan, 1969

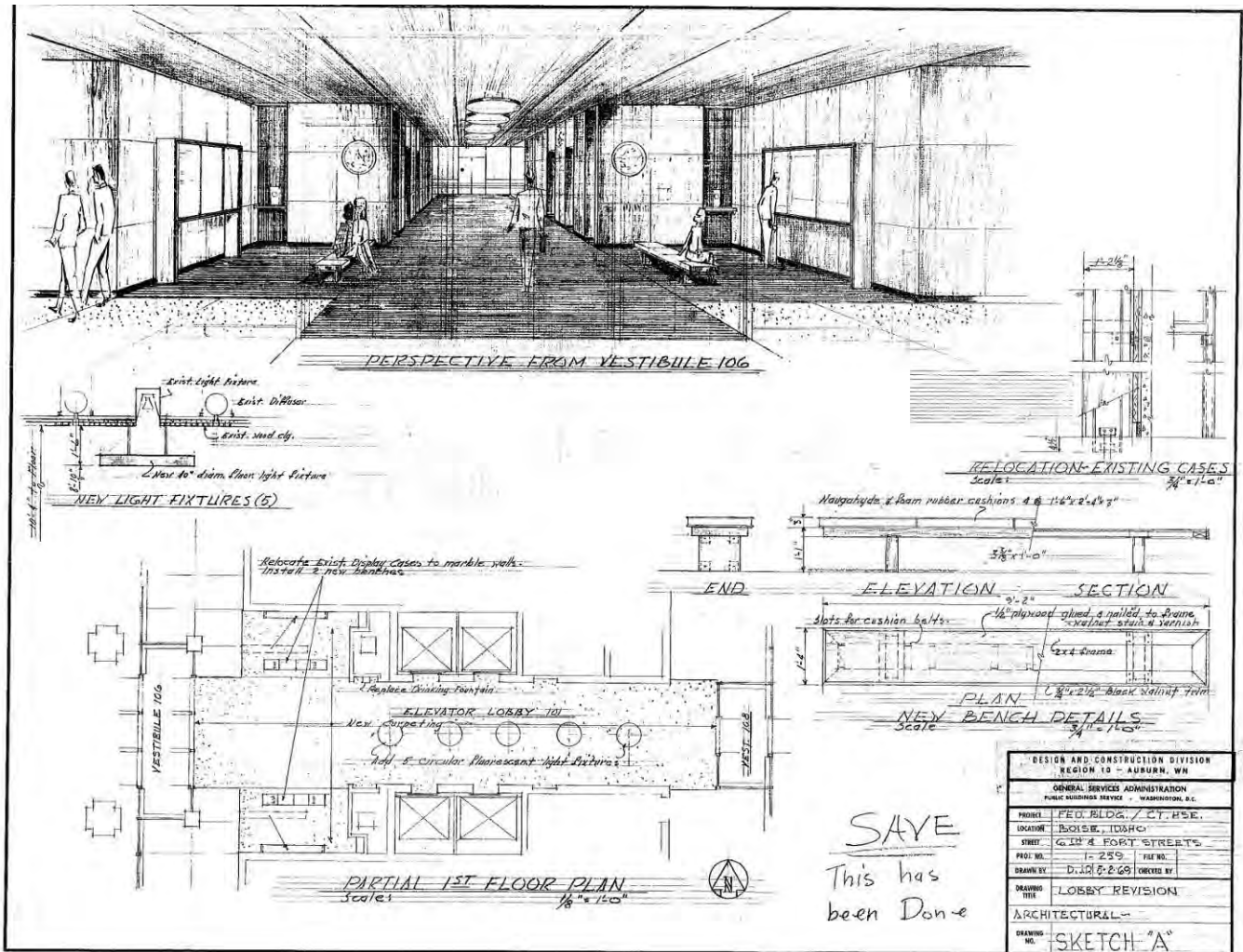

United States Department of the Interior
National Park Service

National Register of Historic Places
Continuation Sheet

Federal Building and U.S. Courthouse
Name of Property
Ada Co., ID
County and State
Name of multiple listing (if applicable)

Section number Additional Documentation

Page 43

Figure 6: Historic Image, original west stair, podium, and first floor entry configuration, 1967



United States Department of the Interior
National Park Service

National Register of Historic Places
Continuation Sheet

Federal Building and U.S. Courthouse

Name of Property

Ada Co., ID

County and State

Name of multiple listing (if applicable)

Section number Additional Documentation

Page 44

Figure 7: Otto Buehner & Company advertisement, 1963

U.S. Central Post Office, Houston, Texas
Architect: Wilson, Morris, Crain & Anderson
General Contractor: C. H. Lovell & Company

Bankers Trust, New York City, N.Y.
Architects: Emery Roth & Sons,
Shreve, Lamb & Harmon Associates,
Henry Dreyfuss, Industrial Designers
General Contractor: Diesel Construction Co., Inc.

Mo-Sai[®]
PRECAST CONCRETE
FACING
AND CURTAIN WALL

Michigan Consolidated Gas Company Office Building,
Detroit, Michigan
Architects: Minoru Yamasaki-Smith, Hinchman,
Greble, Associated Architects and Engineers
General Contractor: Brunt & Datskyer

James White Memorial Auditorium Coliseum, Knoxville, Tennessee
Architect: Painter, Weeks & McCarty and Morton & Steveson
General Contractor: Johnson & Gagnon Company

OTTO BUEHNER & COMPANY
Buehner *Mo-Sai* **Concrete**
Pre-Cast Facing
PRE-STRESSED
PRE-CAST
640 WILMINGTON AVE.
SALT LAKE CITY, UTAH
301 WEST 60TH PLACE
DENVER 16, COLORADO

United States Department of the Interior
National Park Service

National Register of Historic Places
Continuation Sheet

Federal Building and U.S. Courthouse
Name of Property
Ada Co., ID
County and State
Name of multiple listing (if applicable)

Section number Additional Documentation

Page 45

Figure 8: Historic Image, Completed building, c.1969 (Hummel Architects, accessed January 25, 2019 from <http://hummelarch.com/portfolio/james-a-mcclure-federal-bldg/>)



United States Department of the Interior
National Park Service

National Register of Historic Places
Continuation Sheet

Federal Building and U.S. Courthouse
Name of Property
Ada Co., ID
County and State
Name of multiple listing (if applicable)

Section number Additional Documentation

Page 46

Figure 9: Historic Federal Building and U.S. Courthouse rendering, Pre-Occupancy Brochure, 1967 (GSA Archives)



United States Department of the Interior
National Park Service

National Register of Historic Places
Continuation Sheet

Federal Building and U.S. Courthouse
Name of Property
Ada Co., ID
County and State
Name of multiple listing (if applicable)

Section number Additional Documentation

Page 47

Figure 10: Historic Image, Construction photo, 1965 (GSA Archives)

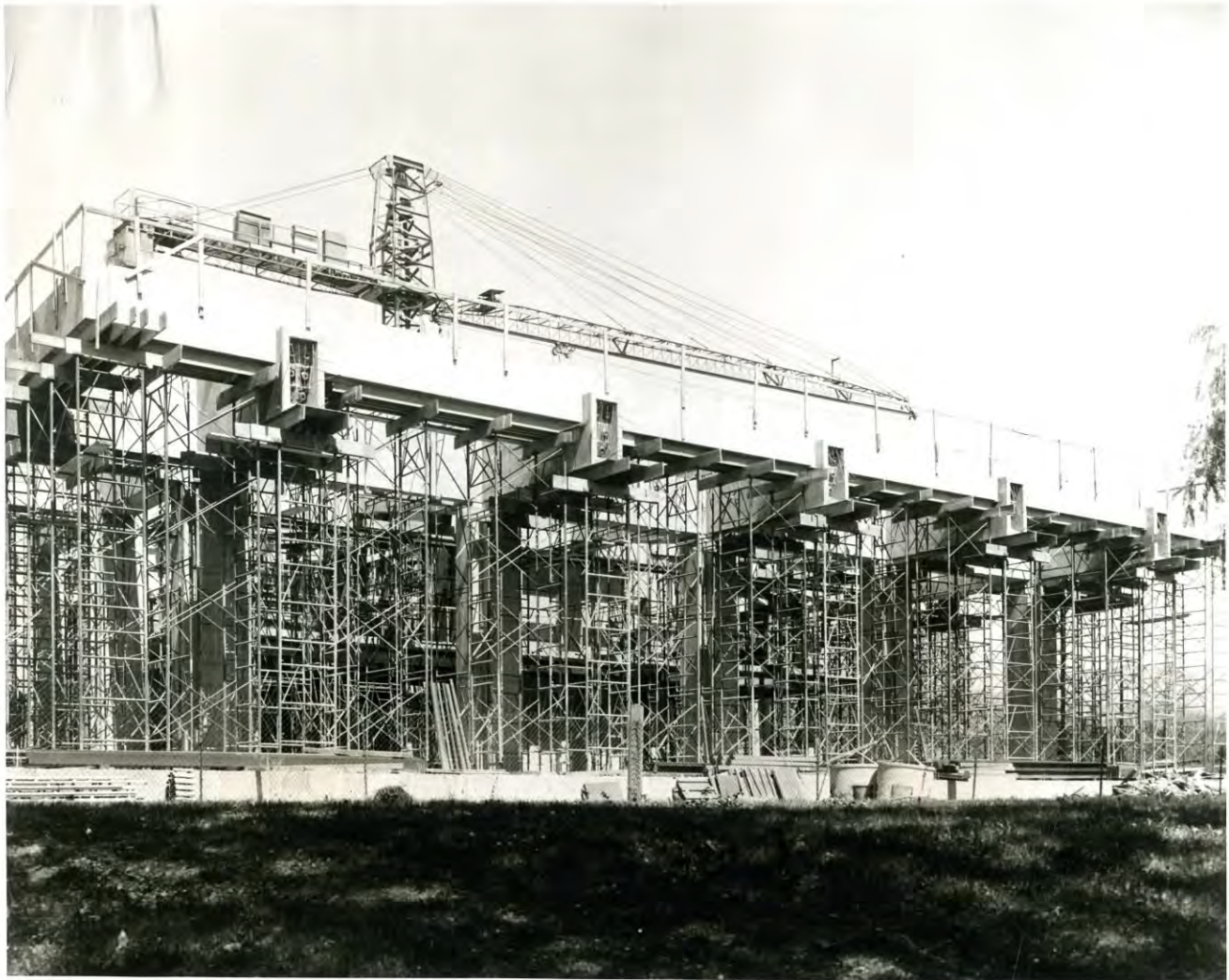

United States Department of the Interior
National Park Service

National Register of Historic Places
Continuation Sheet

Federal Building and U.S. Courthouse
Name of Property
Ada Co., ID
County and State
Name of multiple listing (if applicable)

Section number Additional Documentation

Page 48

Figure 11: Historic Image, Construction of upper floor systems, 1966 (GSA Archives)



United States Department of the Interior
National Park Service

National Register of Historic Places
Continuation Sheet

Federal Building and U.S. Courthouse
Name of Property
Ada Co., ID
County and State
Name of multiple listing (if applicable)

Section number Additional Documentation

Page 49

Figure 12: Historic Image, installation of window modules, 1966 (GSA Archives)



United States Department of the Interior
National Park Service

National Register of Historic Places
Continuation Sheet

Federal Building and U.S. Courthouse
Name of Property
Ada Co., ID
County and State
Name of multiple listing (if applicable)

Section number Additional Documentation

Page 50

Figure 13: Historic Image, precast concrete window module before installation, 1966 (GSA Archives)



United States Department of the Interior
National Park Service

National Register of Historic Places
Continuation Sheet

Federal Building and U.S. Courthouse
Name of Property
Ada Co., ID
County and State
Name of multiple listing (if applicable)

Section number Additional Documentation Page 51

Figure 14: Historic Image, installation of suspended ceiling and mechanical diffusers, 1967 (GSA Archives) (left); Patent 3,440,947 for Combination Diffuser and False Ceiling Suspension Systems, filed September 19, 1966 (Google Patents) (right).

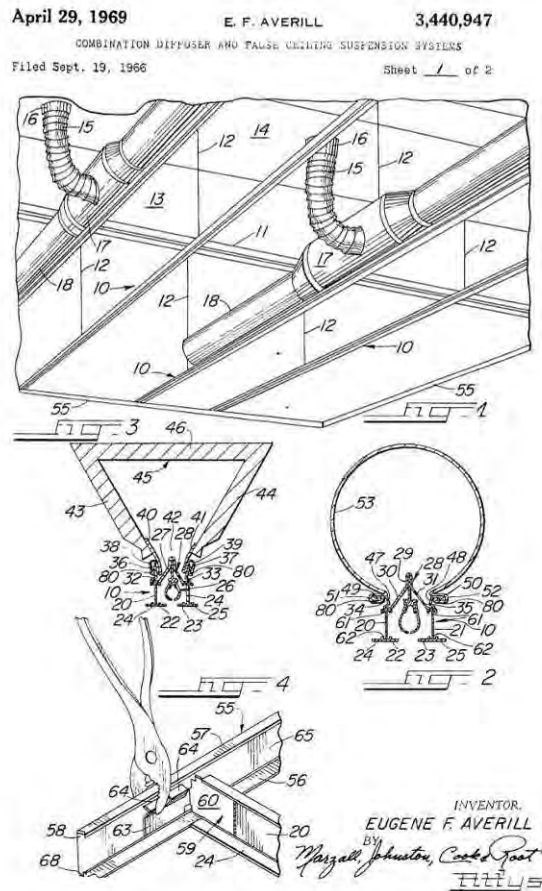

United States Department of the Interior
National Park Service

National Register of Historic Places
Continuation Sheet

Federal Building and U.S. Courthouse
Name of Property
Ada Co., ID
County and State
Name of multiple listing (if applicable)

Section number Additional Documentation

Page 52

Figure 15: Historic Image, roof top window washing scaffold system, 1967 (GSA Archives)



United States Department of the Interior
National Park Service

National Register of Historic Places
Continuation Sheet

Federal Building and U.S. Courthouse
Name of Property
Ada Co., ID
County and State
Name of multiple listing (if applicable)

Section number Additional Documentation

Page 53

Figure 16: West elevation, prior to 2004 First Impressions entry addition (GSA Archives)



United States Department of the Interior
National Park Service

National Register of Historic Places
Continuation Sheet

Federal Building and U.S. Courthouse
Name of Property
Ada Co., ID
County and State
Name of multiple listing (if applicable)

Section number Additional Documentation Page 54

Figure 17: Comparative Analysis, federal buildings: (Clockwise from top left) Saunders Federal Building, Wallace Bennett Federal Building (prior to reskinning in 2002), Charles E. Bennett Federal Building, and Rodino Federal Office Building (prior to reskinning in 2015).



United States Department of the Interior
National Park Service

National Register of Historic Places
Continuation Sheet

Federal Building and U.S. Courthouse
Name of Property
Ada Co., ID
County and State
Name of multiple listing (if applicable)

Section number Additional Documentation

Page 55

Figure 18: Comparative analysis, State of Idaho and City of Boise: (clockwise from top left) Boise Plaza (formerly Boise Cascade), Boise, ID; Idaho Supreme Court, Boise, ID; Idaho Power, Boise, ID.



United States Department of the Interior
National Park Service

National Register of Historic Places
Continuation Sheet

Federal Building and U.S. Courthouse
Name of Property
Ada Co., ID
County and State
Name of multiple listing (if applicable)

Section number Additional Documentation

Page 56



Photo 1 of 26: Primary/west elevation showing entry addition, west parking lot, and landscaping, camera facing southeast.



Photo 2 of 26: Primary/west elevation showing entry addition with vehicular entry guard booth in foreground, camera facing northeast.

United States Department of the Interior
National Park Service

National Register of Historic Places
Continuation Sheet

Federal Building and U.S. Courthouse
Name of Property
Ada Co., ID
County and State
Name of multiple listing (if applicable)

Section number Additional Documentation

Page 57



Photo 3 of 26: Primary/west entrance showing 2004 First Impressions entry addition and 2015 plaza improvements, camera facing east.



Photo 4 of 26: South elevation, camera facing north.

United States Department of the Interior
National Park Service

National Register of Historic Places
Continuation Sheet

Federal Building and U.S. Courthouse
Name of Property
Ada Co., ID
County and State
Name of multiple listing (if applicable)

Section number Additional Documentation

Page 58



Photo 5 of 26: East elevation, view from south edge of Fort Boise parade grounds with camera facing west.



Photo 6 of 26: North elevation and parking lot, camera facing southeast.

United States Department of the Interior
National Park Service

National Register of Historic Places
Continuation Sheet

Federal Building and U.S. Courthouse
Name of Property
Ada Co., ID
County and State
Name of multiple listing (if applicable)

Section number Additional Documentation

Page 59



Photo 7 of 26: Vehicular access ramp to secure basement level parking below podium, camera facing southwest.

**United States Department of the Interior
National Park Service**

**National Register of Historic Places
Continuation Sheet**

Federal Building and U.S. Courthouse
Name of Property
Ada Co., ID
County and State
Name of multiple listing (if applicable)

Section number Additional Documentation

Page 60



Photo 8 of 26: Southeast building corner showing south landscape area, site walls, and Fort Boise stone guard house located between the property line and N. 5th Street, camera facing northwest.



Photo 9 of 26: Mechanical enclosure in north parking lot, camera facing southwest.

**United States Department of the Interior
National Park Service**

**National Register of Historic Places
Continuation Sheet**

Federal Building and U.S. Courthouse
Name of Property
Ada Co., ID
County and State
Name of multiple listing (if applicable)

Section number Additional Documentation

Page 61



Photo 10 of 26: Granite corner stone at southwest corner of podium, camera facing east.



Photo 11 of 26: First floor west lobby interior, camera facing east looking through elevator lobby to east lobby and beyond to Fort Boise parade ground.

United States Department of the Interior
National Park Service

National Register of Historic Places
Continuation Sheet

Federal Building and U.S. Courthouse
Name of Property
Ada Co., ID
County and State
Name of multiple listing (if applicable)

Section number Additional Documentation

Page 62



Photo 12 of 26: 2004 west entry addition lobby, camera looking east toward historic west lobby and showing formerly exterior pilotis and two bays where original entry and curtain wall were removed.

United States Department of the Interior
National Park Service

National Register of Historic Places
Continuation Sheet

Federal Building and U.S. Courthouse
Name of Property
Ada Co., ID
County and State
Name of multiple listing (if applicable)

Section number Additional Documentation

Page 63



Photo 13 of 26: Typical first floor corridor interior, camera facing south.

United States Department of the Interior
National Park Service

National Register of Historic Places
Continuation Sheet

Federal Building and U.S. Courthouse
Name of Property
Ada Co., ID
County and State
Name of multiple listing (if applicable)

Section number Additional Documentation Page 64



Photo 14 of 26: Second floor elevator lobby interior, camera facing west showing glazed wall looking into west entry addition lobby.



Photo 15 of 26: Second floor tenant space interior, camera facing west.

United States Department of the Interior
National Park Service

National Register of Historic Places
Continuation Sheet

Federal Building and U.S. Courthouse
Name of Property
Ada Co., ID
County and State
Name of multiple listing (if applicable)

Section number Additional Documentation

Page 65



Photo 16 of 26: Typical second floor corridor interior, camera facing north.

United States Department of the Interior
National Park Service

National Register of Historic Places
Continuation Sheet

Federal Building and U.S. Courthouse
Name of Property
Ada Co., ID
County and State
Name of multiple listing (if applicable)

Section number Additional Documentation

Page 66



Photo 17 of 26: Typical elevator lobby interior (third floor shown), camera facing west.

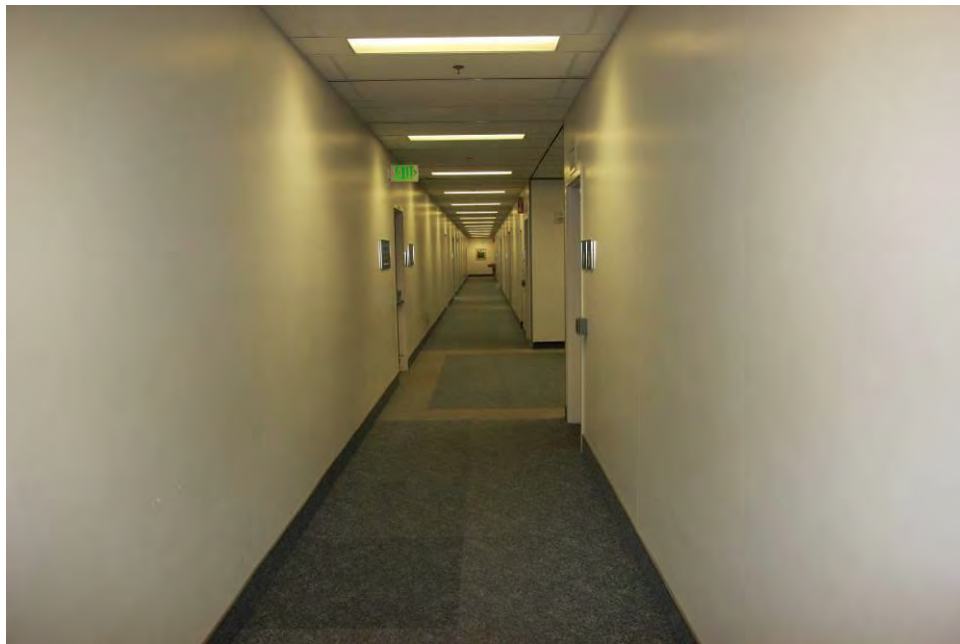

Photo 18 of 26: Typical upper floor corridor interior (third floor), camera facing south.

United States Department of the Interior
National Park Service

National Register of Historic Places
Continuation Sheet

Federal Building and U.S. Courthouse
Name of Property
Ada Co., ID
County and State
Name of multiple listing (if applicable)

Section number Additional Documentation

Page 67



Photo 19 of 26: Typical open office interior (third floor shown), camera facing south.



Photo 20 of 26: Typical original public restroom interior finishes (Men's restroom shown).

**United States Department of the Interior
National Park Service**

**National Register of Historic Places
Continuation Sheet**

Federal Building and U.S. Courthouse
Name of Property
Ada Co., ID
County and State
Name of multiple listing (if applicable)

Section number Additional Documentation

Page 68



Photo 21 of 26: Sixth floor elevator lobby original interior (original courtroom floor), camera facing east.



Photo 22 of 26: Sixth floor court waiting area original interior, camera facing south.

**United States Department of the Interior
National Park Service**

**National Register of Historic Places
Continuation Sheet**

Federal Building and U. S. Courthouse
Name of Property
Ada Co., ID
County and State
Name of multiple listing (if applicable)

Section number _____ Additional Documentation _____

Page 69



Photo 23 of 26: Sixth floor courtroom showing original volume and remodeled interior finishes, camera facing east.



Photo 24 of 26: Added sixth floor courtroom showing wood paneled interior finishes.

United States Department of the Interior
National Park Service

National Register of Historic Places
Continuation Sheet

Federal Building and U.S. Courthouse
Name of Property
Ada Co., ID
County and State
Name of multiple listing (if applicable)

Section number Additional Documentation

Page 70



Photo 25 of 26: Fifth floor elevator lobby remodeled in conjunction with addition of courtrooms at fifth floor.



Photo 26 of 26: Fifth floor courtroom addition





Open 7:30am - 5:30pm

ALL LENSES



JAMES A. McCURE
FEDERAL BUILDING &
UNITED STATES
COURTHOUSE















UNITED STATES OF AMERICA

LYNDON B JOHNSON

PRESIDENT

GENERAL SERVICES ADMINISTRATION

LAWSON B KNOTT JR

ADMINISTRATOR

1966















←EXIT

FLOOR PLAN	
OFFICE	100
CONFERENCE ROOM	101
RECEPTION	102
STORAGE	103
RESTROOM	104
DRINKING WATER	105
STAIRS	106
ELEVATOR	107
EXIT	108









UNITED STATES DISTRICT COURT
JUDGE EDWARD J. LOUGHE







EXIT





UNITED STATES DEPARTMENT OF THE INTERIOR
NATIONAL PARK SERVICE

NATIONAL REGISTER OF HISTORIC PLACES
EVALUATION/RETURN SHEET

Requested Action: Nomination

Property Name: Federal Building and U.S. Courthouse

Multiple Name: _____

State & County: IDAHO, Ada

Date Received: 8/6/2019 Date of Pending List: 8/28/2019 Date of 16th Day: 9/12/2019 Date of 45th Day: 9/20/2019 Date of Weekly List: _____

Reference number: SG100004402

Nominator: Federal Agency, SHPO

Reason For Review:

Appeal

SHPO Request

Waiver

Resubmission

Other

PDIL

Landscape

National

Mobile Resource

TCP

CLG

Text/Data Issue

Photo

Map/Boundary

Period

Less than 50 years

Accept Return Reject 9/19/2019 Date

Abstract/Summary Comments: The Federal Building and U.S. Courthouse (Boise) is of state and local significance under National Register Criteria A and C in the areas of Politics/Government and Architecture respectively. Completed between 1965 and 1968 by the U.S. General Services Administration, the seven-story building is an excellent example of federal Modernist design, in line with the Kennedy administration's historic Guiding Principles for Federal Architecture initiative. The building's straightforward New Formalism design featured a light-weight precast concrete window module curtain wall supported over a massive cantilevered beam system creating an open lower level plaza. The collaborative work of local Modernist architect Charles F. Hummel and Los Angeles-based Charles Luckman Associates, the sizable building consolidated federal agencies scattered throughout the city under a single highly visible roof becoming a significant focal point for regional federal operations.

Recommendation/ Criteria Accept NR Criteria A and C

Reviewer Paul Lusignan

Discipline Historian

Telephone (202)354-2229

Date 09/19/2019

DOCUMENTATION: see attached comments : No see attached SLR : **Yes**



GSA Public Buildings Service



August 6, 2019

Ms. Joy Beasley
Associate Director (acting), Cultural Resources, Partnerships, and Science
Keeper of the National Register of Historic Places
National Park Service
1849 C Street, NW
Room 3316
Washington, DC 20240

Dear Ms. Beasley:

The U.S. General Services Administration (GSA) is pleased to nominate the Federal Building and U.S. Courthouse (current name: James A. McClure Federal Building and U.S. Courthouse) located at 550 W. Fort Street, Boise, Idaho, for inclusion in the National Register of Historic Places. The nomination is hereby submitted on disk in accordance with the May 6, 2013 guidance and includes the following:

- Signed original first page of the National Register of Historic Places nomination form;
- Disk 1 - The enclosed disk contains the true and correct copy of the nomination for the Federal Building and U.S. Courthouse, located in Boise, Idaho, to the National Register of Historic Places; and,
- Disk 2 - The enclosed disk contains the .tif image files for the above referenced nomination.

In accordance with 36 CFR Part 60.9(c), the appropriate local elected officials were notified of GSA's intent to nominate the above referenced property to the National Register of Historic Places by letters dated April 18, 2019.

If for any reason any nomination package that GSA submits needs to be returned, please do so by a delivery service as items returned to our offices via regular mail are irradiated and the materials severely damaged. Should you have any questions or concerns regarding this nomination package, please contact Elizabeth Hannold at (202) 501-2863 or elizabeth.hannold@gsa.gov.

Sincerely,

Beth L. Savage
Federal Preservation Officer
Director, Center for Historic Buildings

Enclosures

cc: Janet Gallimore, Executive Director & State Historic Preservation Officer
Rebecca Nielsen, Regional Historic Preservation Officer

1800 F Street, NW
Washington, DC 20405-0002
www.gsa.gov