

United States Department of the Interior
National Park Service

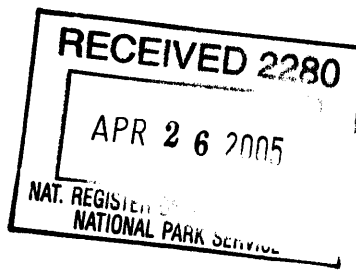

National Register of Historic Places
Registration Form

This form is for use in nominating or requesting determinations for individual properties and districts. See instructions in *How to Complete the National Register of Historic Places Registration Form* (National Register Bulletin 16A) Complete each item by marking "x" in the appropriate box or by entering the information requested. If an item does not apply to the property being documented, enter "N/A" for "not applicable." For functions, architectural classification, materials, and areas of significance, enter only categories and subcategories from the instructions. Place additional entries and narrative items on continuation sheets (NPS Form 10-9000a). Use a typewriter, word processor, or computer, to complete all items.

1. Name of Property

Historic name Shallow Water School
Other name/site number Temporary home to Scott City High School

2. Location

Street & number 180 Barclay Avenue not for publication
City or town Shallow Water vicinity
State Kansas Code KS County Scott Code 171 Zip code 67871

3. State/Federal Agency Certification

As the designated authority under the National Historic Preservation Act, as amended, I hereby certify that this nomination request for determination of eligibility meets the documentation standards for registering properties in the National Register of Historic Places and meets the procedural and professional requirements set forth in 36 CFR Part 60. In my opinion, the property meets does not meet the National Register criteria. I recommend that this property be considered significant nationally statewide locally. (See continuation sheet for additional comments.)

Christy Davis 3/10/05
Signature of certifying official/Title Date
Kansas State Historical Society

State or Federal agency and bureau

In my opinion, the property meets does not meet the National Register criteria. (See continuation sheet for additional Comments.)

Signature of commenting official /Title Date

State or Federal agency and bureau

4. National Park Service Certification

I hereby certify that the property is

- entered in the National Register. See continuation sheet.
- determined eligible for the National Register See continuation sheet.
- determined not eligible for the National Register
- removed from the National Register
- other, (explain:)

Edson Beall 6/9/05
Signature of the Keeper Date of Action

Historic Public Schools of Kansas
Shallow Water School, Scott County, Kansas

5. Classification

Ownership of Property
 (Check as many boxes as apply)

- private
- public-local
- public-State
- public-Federal

Category of Property
 (Check only one box)

- building(s)
- district
- site
- structure
- object

Number of Resources within Property
 (Do not include previously listed resources in the count.)

Contributing	Noncontributing	
1	1	buildings
_____	_____	sites
_____	_____	structures
_____	_____	objects
1	1	total

Name of related multiple property listing
 (Enter "N/A" if property is not part of a multiple property listing.)
 Historic Kansas Public Schools

Number of contributing resources previously listed on the National Register
 0

6. Function or Use

Historic Functions
 (Enter Categories from instructions)

EDUCATION: School

Current Functions
 (Enter categories from instructions)

EDUCATION: School

7. Description

Architectural Classification
 (Enter categories from instructions)

LATE 19th AND 20th CENTURY REVIVALS:
 Mission/Spanish Colonial Revival

Materials
 (Enter categories from instructions)

Foundation: Concrete

Walls: Adobe

Roof: Asbestos

Other:

Narrative Description

(Describe the historic and current condition of the property on one or more continuation sheets.)

Historic Public Schools of Kansas
Shallow Water School, Scott County, Kansas

8. Statement of Significance

Applicable National Register Criteria

(Mark "X" in one or more boxes for the criteria qualifying the property for National Register)

- A** Property is associated with events that have made a significant contribution to the broad patterns of our history
- B** Property is associated with the lives of persons significant in our past.
- C** Property embodies the distinctive characteristics of a type, period, or method of construction or represents the work of a master, or possesses high artistic values, or represents a significant and distinguishable entity whose components lack individual distinction.
- D** Property has yielded, or likely to yield, information important in prehistory or history.

Criteria Considerations

(Mark "x" in all the boxes that apply.)

Property is:

- A** owned by a religious institution or used for religious purposes.
- B** removed from its original location.
- C** a birthplace or grave.
- D** a cemetery.
- E** a reconstructed building, object, or structure.
- F** a commemorative property.
- G** less than 50 years of age or achieved significance within the past 50 years

Narrative Statement of Significance

(Explain the significance of the property on one or more continuation sheets.)

Areas of Significance

(Enter categories from instructions)

EDUCATION

ARCHITECTURE

Period of Significance

1939 - 1955

Significant Dates

1939-42

Significant Person

(Complete if Criterion B is marked above)

Cultural Affiliation

Architect/Builder

Architect : MANN & CO. of Hutchinson; Builder: ED HASZ

9. Major Bibliographical References

Bibliography

(Cite the books, articles, and other sources used in preparing this form on one or more continuation sheets.)

Previous documentation on file (NPS): Primary location of additional data:

- preliminary determination of individual listing (36 CFR 67) has been requested
- Previously listed in the National Register
- previously determined eligible by the National Register
- designated a National Historic Landmark
- recorded by Historic American Buildings Survey # _____
- recorded by Historic American Engineering Record # _____

- State Historic Preservation Office
- Other State agency
- Federal agency
- Local government
- University
- Other

Name of repository:

Historic Public Schools of Kansas
Shallow Water School, Scott County, Kansas

10. Geographical Data

Acreage of Property: less than 1 acre _____

UTM References

(Place additional UTM references on a continuation sheet.)

1	1 4	3 3 2 9 6 0	4 2 4 9 1 4 5	3			
	Zone	Easting	Northing		Zone	Easting	Northing
2				4			

See continuation sheet

Verbal Boundary Description

(Describe the boundaries of the property on a continuation sheet.)

Boundary Justification

(Explain why the boundaries were selected on a continuation sheet.)

11. Form Prepared By

Name/title Brenda R. Spencer

Organization Preservation Planning and Design Date 10 September, 2004

Street & number 10150 Onaga Road Telephone 785-456-9857

City or town Wamego State Kansas Zip code 66547

Additional Documentation

Submit the following items with the completed form:

Continuation Sheets

Maps

A **USGS map** (7.5 or 15 minute series) indicating the property's location.

A **Sketch map** for historic districts and properties having large acreage or numerous resources.

Photographs

Representative **black and white photographs** of the property.

Additional items

(Check with SHPO or FPO for any additional items)

Property Owner

name USD 466 Scott County, Mr. Dean Katt, Superintendent

street & number 704 College, P.O. Box 288 telephone 620-872-7600

city or town Scott City state Kansas zip code 67871

Paperwork Reduction Act Statement: This information is being collected for applications to the National Register of Historic Places to nominate properties for listing or determine eligibility for listing, to list properties, and to amend existing listings. Response to this request is required to obtain a benefit in accordance with the National Historic Preservation Act, as amended (16 U.S.C. 470 et seq.).

Estimated Burden Statement: Public reporting burden for this form is estimated to average 18.1 hours per response including time for reviewing instructions, gathering and maintaining data, and completing and reviewing the form. Direct comments regarding this burden estimate or any aspect of this form to the Chief, Administrative Services Division, National Park Service, P.O. Box 37127, Washington, DC 20013-7127; and the Office of Management and Budget, Paperwork Reductions Projects (1024-0018), Washington, DC 20503

**United States Department of the Interior
National Park Service**

**National Register of Historic Places
Continuation Sheet**

Section: 7 Page: 5

**Historic Public Schools of Kansas
Shallow Water School, Scott County, Kansas**

Narrative Description

The Shallow Water School was constructed 1939-1942 through the Works Projects Administration (WPA Project #40110). It is a one-story adobe structure, L shaped in plan with classrooms around a central gymnasium. The building is a traditional adobe structure with projecting wood posts around the perimeter and beveled piers dividing each facade into multiple bays. The front facade is symmetrical with a central entrance. All windows are multi-paned steel windows, most with operable hopper and awning panels.

The roof of the main building is flat and the gym has a gable roof, both originally built-up roofs. The gable gym roof is now composition shingles. A large round stucco chimney extends above the structure at the northeast corner of the building. The parapet extends above the surface of the flat roof around the perimeter of the building. There are built-in scuppers with downspouts located between windows.

The school playground/city park is a full city block in the center of the town of Shallow Water, bordered on the south by Main Street. The school faces the playground, located across Barclay Street to the south. The school site is bordered by unpaved streets on the south and west with an open field at the rear. A drive off Barclay Street accesses parking on the east and north sides of the school. Concrete sidewalks run along the perimeter of the site and the perimeter of the school on the front (south) and east sides. A walk extends to the front central entrance. A grass lawn with multiple mature trees is in place on the south and east sides of the building. A stucco addition was built on the northwest corner of the building in 1962 and a one story brick addition was built on the west side in 1964. A one-story stucco shop/bus garage is in place northeast of the school that was built c. 1962.

The structure is standard adobe construction with seasoned adobe clay blocks coated with two inches of stucco on the exterior and one inch of plaster on the interior. The original construction drawings identify the location of the sand and sod to be used to make the clay bricks (White Woman Basin west of Shallow Water). The bricks were 16" x 24" x 4-5". The building has a concrete foundation and adobe perimeter and partition walls. With the exception of the horizontal timber poles, the only wood framing is the truss forming the gable roof over the gym.

The former school building, a one and a half story stucco frame structure, was located at the southwest corner of the adobe building. The foundation plan for the adobe building illustrates that some of the walls of the former school were retained and incorporated into the structure of the existing building.

The front (south) facade is comprised of five bays, the center bay being the main building entrance. The parapet is raised over the entrance with a scalloped pattern molded in the stucco. Heavy timber brackets support a wood canopy over the front entry. Timber poles extend from the canopy to the recesses entrance. The original doors were a pair of multi-pane paneled wood doors with multi-pane sidelights and transom. The original recessed entrance was enclosed, forming an entry foyer. Contemporary metal-frame glass doors have been installed, surrounded by contemporary wood siding. The timber brackets and canopy are extant. The interior foyer doors have been removed but the original sidelights and transoms are in place. The center entry bay is flanked by two identical bays on each side. Each bay is comprised of four windows, two smaller windows flanking two larger windows in the center. The tapered piers are located between each bay with timbers projecting between the windows.

The east and west elevations are asymmetrical with varying configurations and sizes of windows. The original west elevation is nearly obscured by the 1964 one-story brick addition. The addition is offset from the original building by approximately eight feet, connected by the rear addition off the northwest corner of the original building. The original windows are in place on the west facade. A shop was originally located in the north end of the east side of the building, extending beyond the gymnasium. The north end of the east facade was comprised of four garage bays with multi-pane glass paneled doors at the north end. This area has been modified. The full-height glass garage doors have been removed, the openings downsized, and new aluminum windows installed. The door on the east side has also been replaced. The original multi-pane steel windows are extant. The windows have pre-cast concrete sills. There are clerestory windows on the east and west gable ends of the gymnasium.

**United States Department of the Interior
National Park Service**

**National Register of Historic Places
Continuation Sheet**

Section: 7 Page: 6

**Historic Public Schools of Kansas
Shallow Water School, Scott County, Kansas**

The 1962 addition is located off of the rear of the original building, in the L created by the east wing. The addition is offset from the original building, creating a breezeway between the rear of the gymnasium and the east wing, and the rear addition. The rear addition extends beyond the original building on the west side, connecting to the brick addition on the west. Only the east end of the original building is visible from the rear. It is a solid stucco wall, framed by tapered piers on each end.

The freestanding garage is located north of the east wing in the rear of the school. The building has two overhead garage doors and a single door in the center on the south facade. It appears that two additional bays have been filled in and stuccoed over. The building is a simple rectangular plan with a flat roof. It is now used as a weightlifting room.

The plan configuration of the original building is an L shaped corridor around a central gymnasium. The original plans are provided at the end of the nomination. Classrooms were located around the perimeter of the building. The office was off the front entry foyer and restrooms were located on the north end of both the east and west sides. The plan offered standard classroom space with no real customized spaces except the shop. The central gymnasium also functioned as an auditorium. The gymnasium is sunken, with five rows of bleachers (wood planks on concrete steps) on the south side and a stage in the center of the north side. The vaulted ceiling has applied acoustic tile ceiling panels. The walls are plaster coating over adobe bricks. Carpet has been added on the bleachers and extends up the rear (north) wall. The grade school was located on the east side, the high school on the west.

The floors are the original 8" vinyl asbestos tile flooring and the walls are plaster over adobe with curved corners throughout. The ceilings are applied acoustic tile, with the exception of the northeast corner which is suspended acoustic tile. It appears that the ceilings have been lowered. The construction drawings note an 11' ceiling height throughout but only the entry foyer retains the original 11' ceiling height. There are surface mounted florescent lights in the corridors and classrooms. A single original light fixture is extant in the former boy's restroom, now used for storage. The original multi-pane paneled wood doors are in place on the interior of the building. The doors are unique nine light over two louvered panels, wood doors. Eight perimeter panes are patterned opaque glass surrounding a center transparent pane. There are clerestory windows from the corridors into classrooms. Most classrooms have built-in wardrobes extant and original chalkboards. There are a few original customized features such as a sink in the original kindergarten room in the center of the east wing.

The 1961-62 addition provided a cafeteria, new restrooms, locker rooms, a band/music room, and a science room. It was designed by Lyman, Jones & Cobb of Garden City and constructed by Johnson Builders, Inc. of Salina. The one-story stucco addition was built off the northwest corner and is clearly distinguished from the original building. The addition has a flat roof and aluminum windows with horizontal panes. The interior is concrete block with acoustic tile ceilings and VAT flooring. A second addition was built the following year - a simple rectangular plan form spanning the west side of the original building and first addition. The west addition is a one story tan brick structure with a flat roof and glass block over horizontal aluminum windows. The interior is concrete block with suspended acoustic tile ceilings and VAT flooring. This addition was designed to house the grade school.

Aside from the two additions, the remodeling of the original shop on the northeast corner is the only alteration of the original plan configuration. The original bathrooms are no longer used as student restrooms. The original girl's restroom (west side) is a teachers' restroom, complete with original bead board stalls and stucco shower area. The east original bathroom is now storage/custodial room. When the shop was converted to classrooms, the original glass paneled garage doors were removed, the openings downsized and aluminum windows installed. The recessed entry was enclosed forming a foyer, and in the 1960s, the Student Council raised money to purchase window air conditioners for high school classrooms. Window air conditioning units are in place in some windows.

**United States Department of the Interior
National Park Service**

**National Register of Historic Places
Continuation Sheet**

Section: 8 Page: 7

**Historic Public Schools of Kansas
Shallow Water School, Scott County, Kansas**

Narrative Statement of Significance

Shallow Water School was built between 1939 and 1942 through the Works Projects Administration (WPA). The school is significant under Criterion A as Shallow Water's only extant public school, and under Criterion C as the only known adobe school building in the state of Kansas. The school is significant on a state and local level. It is representative of the Town Graded School property type and meets the registration requirements set forth in the multiple property documentation form, *Historic Public Schools of Kansas*. The period of significance spans from the date of construction in 1942 to 1955. The Shallow Water School is significant as a representative of WPA schools in Kansas and the first graded school in Shallow Water that included a gymnasium and offered twelve years of school instruction in a single building. As a traditional adobe structure, the school is classified as a Mission/Spanish Colonial Revival building and was designed by the prominent architectural and engineering firm, Mann and Company, in Hutchinson.

The Town of Shallow Water

Shallow Water is a small community located in southern Scott County between Oakley and Garden City in southwest Kansas. The largest community in the county is Scott City, with seventy-five percent of the county's 5,000 residents. Shallow Water is located seven miles south of Scott City, off Highway 83. The community got its name from the shallow water table, near the earth's surface. The town was established in 1912 when H.J. Mott was given a half-section of land by the Friends Society (Quaker Church). The town was surveyed in June of 1912 and many of the streets were given Quaker names. A small frame building was moved to town to be used as the first school. The existing school stands on the site of the original school.

The Friends Society built the first church in the community in 1914 and a post office and general store opened in 1916. The town was a small, close community even in its early years. In the 1920s, there were several residences, an elevator, lumber yard, garage, general store, and post office. The railroad was the centerpiece of the community. The Garden City Gulf and Northern Railroad ran between Scott City and Garden City with a stop in Shallow Water. In the early days, it took two trains to transport farmers and their families from Shallow Water to the city park in Scott City for Saturday picnics. Stockyards were located along the track in Shallow Water and farmers would drive their cattle to the stockyards to be shipped to Kansas City. At its peak, there were two elevators in town, and a small depot. The church has long been a center of the Shallow Water community. Prior to construction of the existing school, the church was used for graduation exercises and school plays. Following construction of the new school, the former one-room school, used for a music room with the new school, was used as the church with Sunday School classes held in the new school building. A new church was built in 1960 and the school still uses the church for some school functions. The church remains the center of the community today. The only operating business is the grain elevator and the school continues to be used for community activities.

The Schools of Shallow Water

The first record of a school in Scott County was a subscription (tuition-based) school that began in 1886 and was taught by the County Superintendent. Scott City was established in 1885 and in 1887-88, thirty seven districts were organized in the county. The first high school in the county was established in Scott City in 1901, a single course of study held in one room of the grade school. In 1920, three districts around Manning voted to consolidate and built the first consolidated school in the county, consisting of a grade school and four-year high school. Modoc also had a high school and the existing Scott City Community High School was constructed in 1930.

The first grade school was taught in Shallow Water in the fall of 1912, shortly after the town was established. By 1917, a new stucco frame building was constructed and in 1918, a second teacher was hired to start a two-year high school. The following year, another teacher was added and the high school became a four-year program. The new school was one and half stories with two rooms per floor. The two rooms upstairs were used for grades 3-8 and the high school was held downstairs. The former one-room schoolhouse remained on the site, east of the new school and was used for the first and second grades. The first class (two students) graduated from the high school in 1922. Shallow Water consolidated with the district to the west in 1924, forming Shallow Water Consolidated District #10. A bus was used to transport students after consolidation.

**United States Department of the Interior
National Park Service****National Register of Historic Places
Continuation Sheet**

Section: 8 Page: 8

**Historic Public Schools of Kansas
Shallow Water School, Scott County, Kansas**

The stucco school was replaced by the existing adobe school. A portion of the former school was incorporated into the structure of the adobe school. Plans for the current school were developed in 1939 by Mann & Company architects of Hutchinson, who had designed Scott City High School in 1930. School officials tried to pass a bond issue to finance the new school but the first attempt failed. A second attempt passed after the language was revised to reflect the construction of a building for community purposes that could be used by all residents, regardless of whether they had school-age children. The community received assistance for the school through the Works Projects Administration. The only professionals on the project were the architect and builder/construction supervisor. Local residents report that WPA required that projects be constructed of materials indigenous to the area. The lack of local trees or stone is cited as the reason for the decision to build an adobe structure. The WPA hired local workers to build the school. The adobe bricks were made on site. Soil from the White Woman Basin was mixed with lighter soil on the school site, and wheat straw added as a binding agent. The local blacksmith, Pop Neuenschwander, constructed a mixer out of 55 gallon drums, attached to a Model T chassis. Water was added to the soil mixture to achieve the desired consistency and the clay was poured into forms on the site. The wood forms framed several bricks and were designed with handles so that the bricks could be turned over to bake in the sun. When partially dried, the form was removed and individual bricks cut and allowed to season up to a year. Sand was brought in from the creek bed and sifted through a large screen sieve for use in the mortar to set the adobe bricks. The school opened in the fall of 1942 and the gymnasium was the last space to be completed, later in the school year. The construction was labor intensive and spanned several months providing needed employment for local residents. The school is the only known adobe school in Kansas and locals claim it is the largest adobe school building in the world. Expansions in 1962 and 1963 brought the school to its current form.

The original design for the school included teacher cottages, west of the school building. These cottages were not built but at least one teacher did reside in the school in a small apartment in the northeast corner of the building. The district has an established history of providing housing for school officials. A house, east of the school, was later provided for the principal.

There were over thirty operating country schools in Scott County in the 1940s. In the early 1950s there were still 17 separate school districts in Scott County. By the mid-1960s consolidation efforts had reduced the number to six. Manning, Beaver Flats, and Modoc each had an elementary school. Scott City had separate districts for its elementary and high school and Shallow Water had a combined elementary and high school. The state legislation of 1963 and 1965 mandated consolidation of districts throughout the state. Scott County Unified School District No. 466 was formed in 1966, encompassing all of Scott County and small portions of Wichita, Logan and Lane counties. In 1969, the high school in Shallow Water was closed and by the mid-1970s, the elementary schools in Modoc and Manning were also closed. For the next twenty-five years, Scott County schools included elementary schools in Shallow Water, Beaver Flats, and Scott City, and a Middle School and High School in Scott City. Following consolidation, the Shallow Water School served grades K-8 and later K-6. The school was closed in 2003 and is temporarily being used as Scott City High School while the school in Scott City is undergoing remodeling. Later this year, the school will be vacated. The future use of the structure is uncertain and a number of options are being explored. There is a commitment to keep the building in public hands, open for community use.

Summary

The Shallow Water School was constructed in 1942 through the WPA. It was the first school in the community, to include a gymnasium and to house all grades in a single structure. As an adobe structure, the school is classified as a Mission/Spanish Colonial Revival style building. An atypical representative of New Deal schools in Kansas, the Shallow Water School is unique in that it is the only known adobe school in the state of Kansas.

The one story school is traditional adobe construction with a stucco coating over adobe bricks, exposed timbers and tapered piers, and a large round, tapered chimney. The property maintains integrity of location, setting, design, materials, workmanship and association. The school meets the registration requirements set forth in the multiple property documentation form. The school retains its original form (with the exception of rear and side additions), its original roof shape, exterior materials, original windows, and interior corridor configuration.

**United States Department of the Interior
National Park Service**

**National Register of Historic Places
Continuation Sheet**

Section: 8 Page: 9

**Historic Public Schools of Kansas
Shallow Water School, Scott County, Kansas**

The alterations to the school include minor interior remodeling and two major additions. The additions are both off of secondary facades and clearly distinguished from the original building. The modifications are within the parameters defined in the multiple property documentation form and do not sufficiently impact the integrity of the property.

The school served the Shallow Water community for twenty-five years offering instruction for all grades, K-12. The high school closed in 1969, four years after consolidation. The grade school continued operation until 2003. The school currently serves as the temporary home to Scott City High School. It will be vacated when the current construction project at the high school in Scott City is completed (2005).

The Shallow Water School is nominated for listing on the National Register under the multiple property documentation form, *Historic Public Schools of Kansas*, as a representative of the Town Graded School property type, designed to serve all grades and distinguished as the only school in the community.. The building is eligible under National Register Criterion A and C. It is significant as the public school in Shallow Water, serving the community for over sixty years, and as a representative of the many schools constructed in Kansas through the Works Projects Administration in the 1930s-40s. The school is significant architecturally as the only known adobe school in the state and as a representative of the work of prominent Hutchinson architectural firm, Mann and Company, who designed hundreds of schools in the state of Kansas (see Appendix C of the *Historic Public Schools of Kansas* multiple property documentation form for a complete listing of their work).

**United States Department of the Interior
National Park Service**

**National Register of Historic Places
Continuation Sheet**

Section: 9-10 & Additional Documentation Page: 10

**Historic Public Schools of Kansas
Shallow Water School, Scott County, Kansas**

Bibliography

History of Early School County. Scott county Historical Society, 1977. 284-288.

Scott County Kansas Centennial 1886-1986. Scott County Centennial Commission, Inc. 1986. 105.

Shallow Water School Tiger Tales. Special 2000 Reunion Edition.

Shallow Water School Yearbook. American Yearbook Company, 1969.

Spencer, Brenda R. *Historic Public Schools of Kansas*, National Register Multiple Property Nomination, 2004.

Spencer, Brenda R. Shallow Water School Reconnaissance Inventory Form, June, 2004.

Information on the history of Shallow Water, the history of the school, and historic photos of the school was provided by local residents Tom Graham and Kay Molder at the El Quartejejo Museum in Scott City.

Additional information on the school was provided by local residents Roy Fairleigh and Charles Duff, through the school district.

The original construction drawings were obtained from Mann & Co. of Hutchinson.

Geographical Data

Verbal Boundary Description – Lots 1, 2, 3, and North half of vacated alley lying South and Adjacent, Shallow Water. The site is bordered on the south by Barclay Street and by unpaved roads/drives on the east and west. A field is located behind the school to the north.

Boundary Justification – The site is comprised of the school building and grounds and is clearly defined by geographic features.

Additional Documentation

Maps

USGS map attached

Plans and Historic Views

Figure 1 – Historic Views of Shallow Water School Buildings

Figure 2 – Original Construction Documents, provided by Mann & Co., Architects and Engineers of Hutchinson, Kansas

Figure 3 – Plan of existing school, provided by USD 466.

**United States Department of the Interior
National Park Service**

**National Register of Historic Places
Continuation Sheet**

Section: 9-10 & Additional Documentation Page: 11

**Historic Public Schools of Kansas
Shallow Water School, Scott County, Kansas**

Photographs

Photos were taken by Brenda Spencer August 20, 2004. KSHS holds the original negatives.

<u>#</u>	<u>Description of View [direction of camera]</u>
1	East and south (front) facades from southeast corner of site [northwest]
2	Front (south) facade [north]
3	Detail of entrance [northwest]
4	Detail of entry canopy [north]
5	West facade, 1964 brick addition [east]
6	Rear (north) facade from northwest corner of site [southeast]
7	Rear garage c. 1962 [northwest]
8	East facade [west]
9	Detail of exterior piers, timbers, scupper/downspout, and window, east facade [northwest]
10	Entry foyer [southwest]
11	Typical classroom with built-in cabinets, south side of building [east]
12	Original girl's bath room, west side of building [northwest]
13	Typical interior door, west wing [west]
14	Interior view of typical window [east]
15	Original light fixture, located in former boy's restroom, east wing [east]
16	Gymnasium [northeast]

**United States Department of the Interior
National Park Service**

**National Register of Historic Places
Continuation Sheet**

Section: 9-10 & Additional Documentation Page: 12

**Historic Public Schools of Kansas
Shallow Water School, Scott County, Kansas**

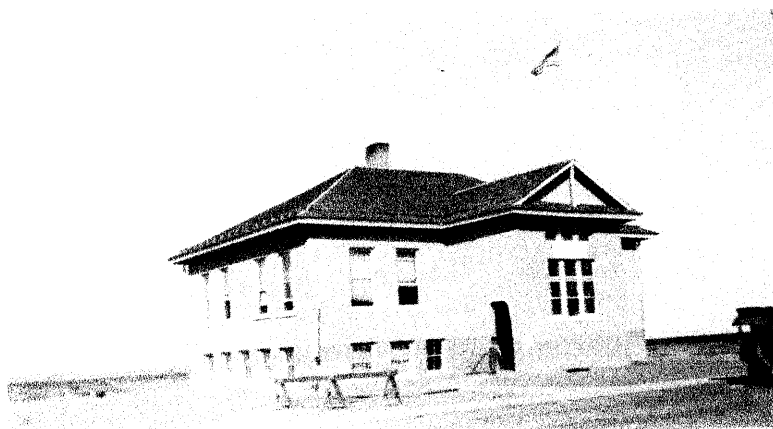

Shallow Water Schoolhouse for 1st and 2nd grade. 1938

Figure 1 – Historic Views of Shallow Water Schools

Top Left: Stucco and frame school built on same site as existing school (1917). Walls and foundation of this building were incorporated into the existing adobe structure.

Top Right: First Schoolhouse - moved to current school site after town was established in 1912. Building was located east of stucco school building and removed when existing adobe school was built. Both photos were provided by the El Quartejejo Museum in Scott City.

Lower: View of existing school illustrating original recessed entry. The 1969 Shallow Water School Yearbook, provided by Kay Molder.

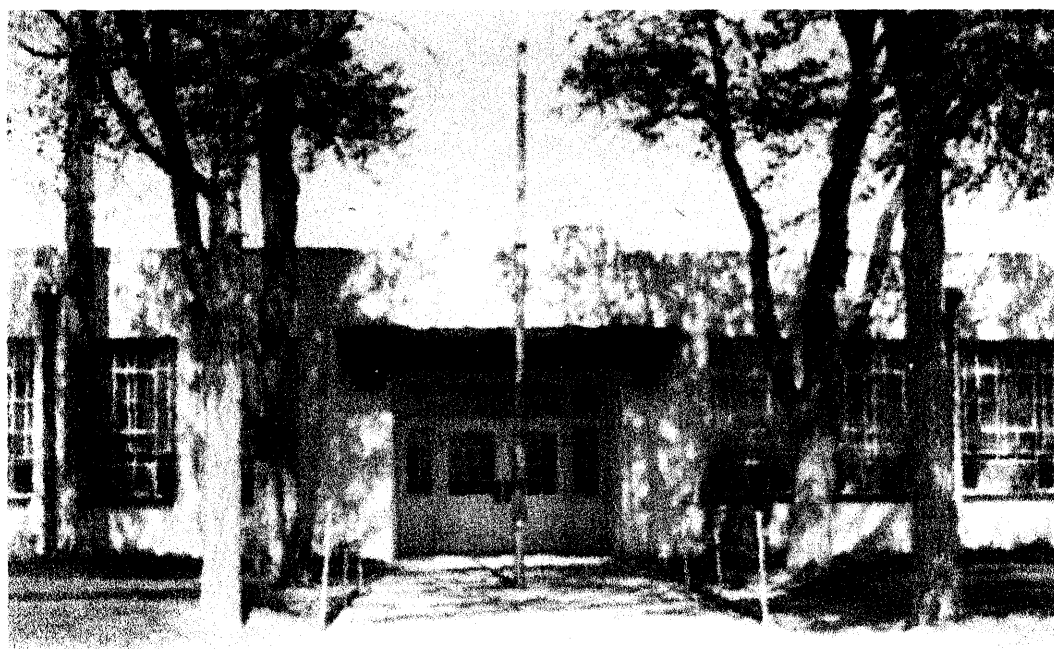
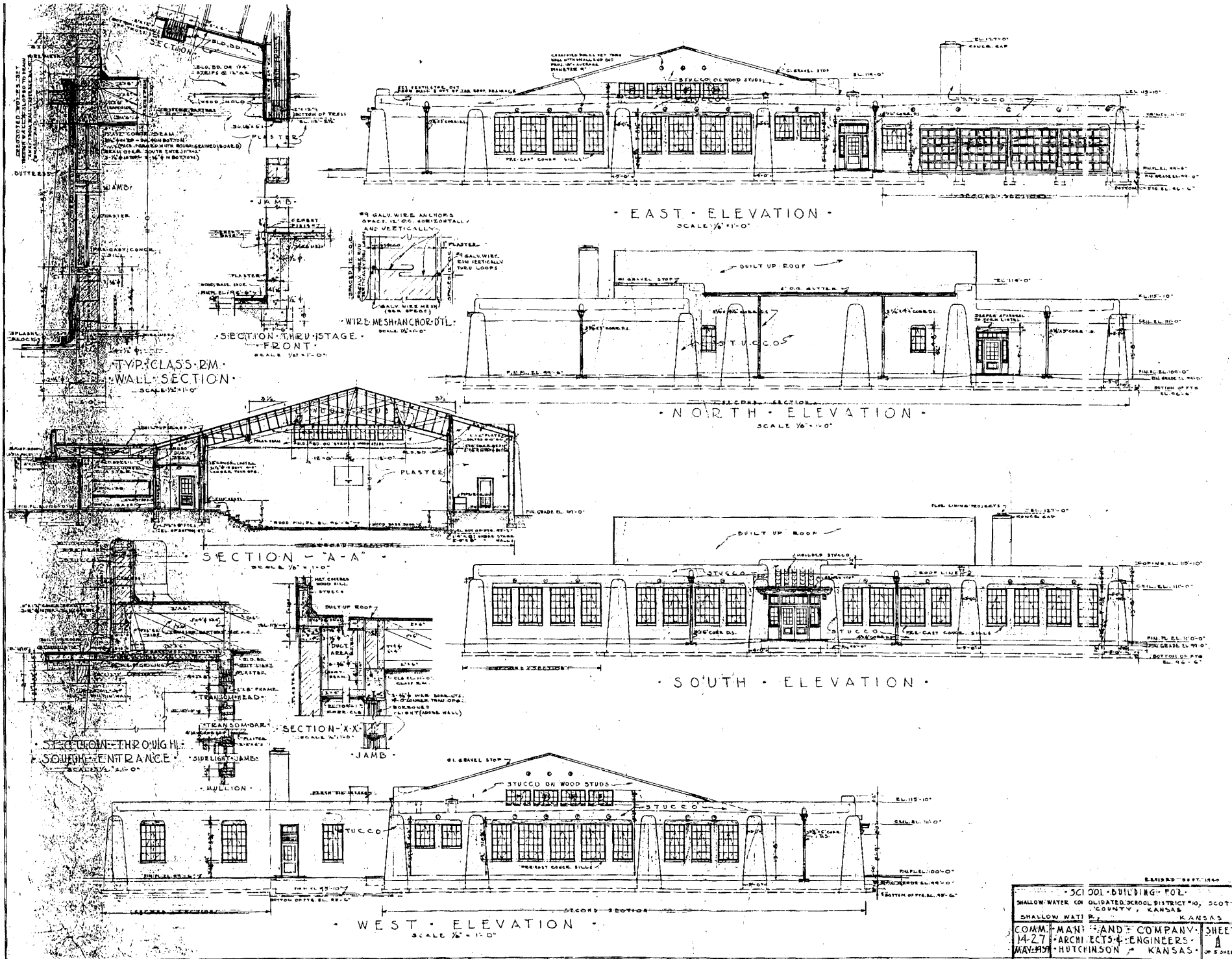

Figure 2 - Original 1939 Construction Documents by Mann and Company Architects and Engineers of Hutchinson



SCHOOL BUILDING - POL.
 SHALLOW WATER CO. OLIVATED SCHOOL DISTRICT NO. 20, SCOTT COUNTY, KANSAS
 SHALLOW WATER, KANSAS
 COMM. MAN. AND COMPANY SHEET 14-27 ARCHITECTS & ENGINEERS MAY 23, 1939 HUTCHINSON, KANSAS 1 OF 2 SHEETS



STATE OF KANSAS
 SHOWING AVAILABLE LOCATIONS
 FOR OBTAINING SAND AND SOIL
 SCALE 1" = 2 MILES

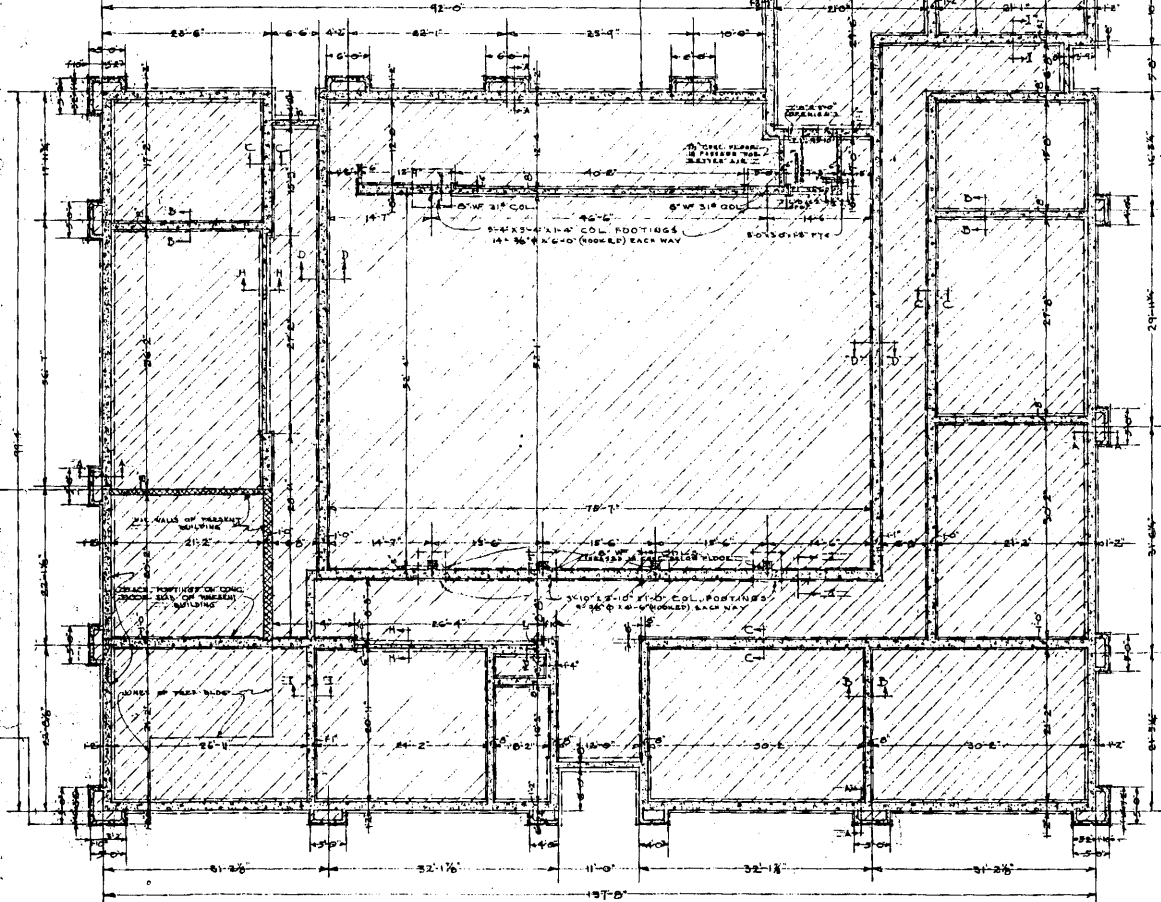

FOOTING AND FOUNDATION PLAN
 SCALE 1/4" = 1'-0"

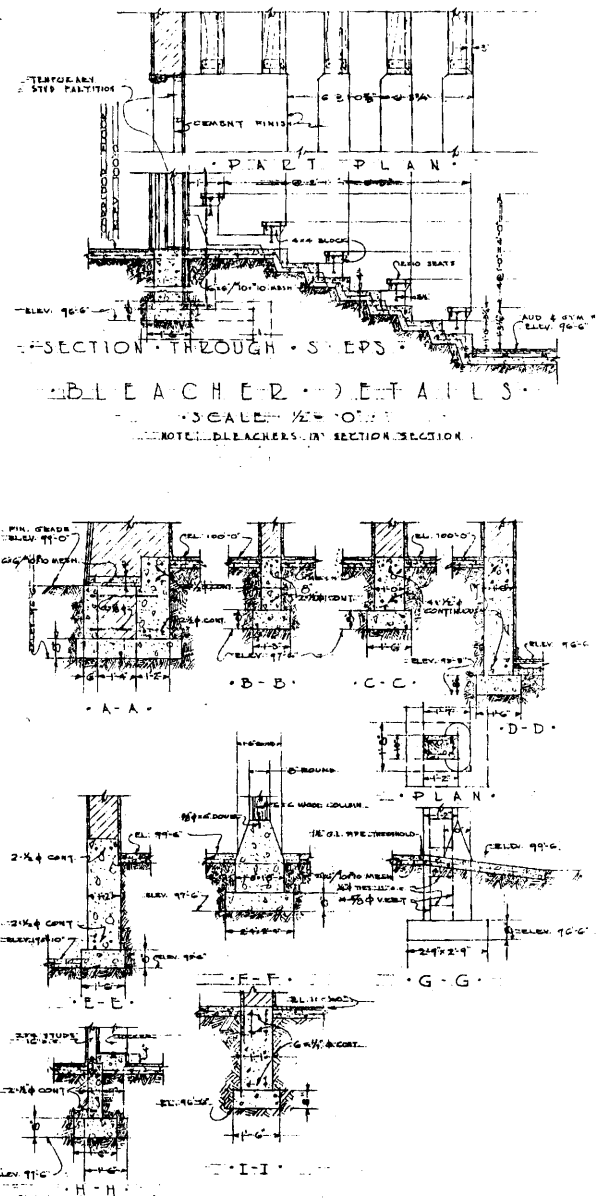
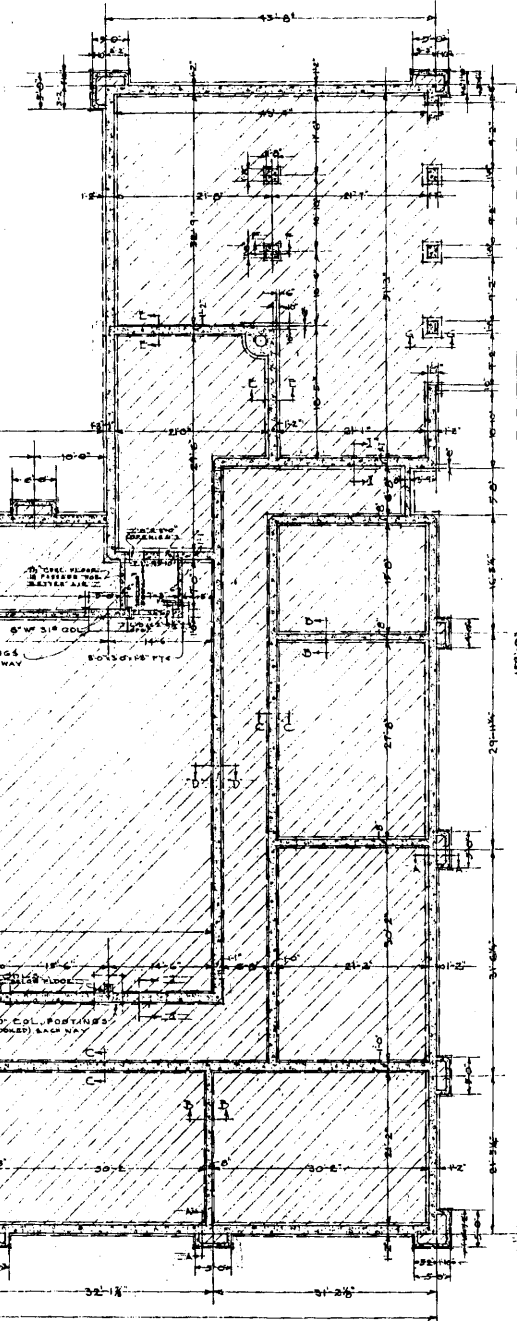

SCHEDULE OF WALL INDICATIONS

FIRST SECTION CONCRETE WALLS	[Pattern]
SECOND SECTION CONCRETE WALLS	[Pattern]
FIRST SECTION ADOBE WALLS	[Pattern]
SECOND SECTION ADOBE WALLS	[Pattern]

REVISED SEPT. 1910
 SCHOOL BUILDING FOR
 SHALLOW WATER CONSOLIDATED SCHOOL DISTRICT NO. 500
 COUNTY, KANSAS
 SHALLOW WATER, KANSAS
 CHAS. MANN AND COMPANY
 14-27 ARCHITECTS & ENGINEERS
 MAY-1939 HUTCHINSON, KANSAS

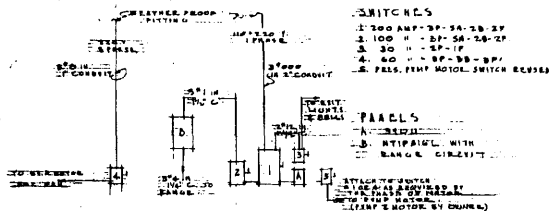

ELECTRIC DIAGRAM
NOT TO SCALE

SYMBOLS		SYMBOLS	
5	INDICATOR LAMP	○	MOTOR OUTLET
6	INDICATOR LAMP	○	THERMOSTAT LOCATION
7	INDICATOR LAMP	○	WALL MATERIAL
8	INDICATOR LAMP	○	ELECTRONIC OUTLET
9	INDICATOR LAMP	○	ROUNDOUT
10	INDICATOR LAMP	○	GENERAL LIGHT OUTLET
11	INDICATOR LAMP	○	ROOM - EXTERIOR
12	INDICATOR LAMP	○	HALL - INTERIOR
13	INDICATOR LAMP	○	REHISTAT
14	INDICATOR LAMP	○	
15	INDICATOR LAMP	○	
16	INDICATOR LAMP	○	
17	INDICATOR LAMP	○	
18	INDICATOR LAMP	○	
19	INDICATOR LAMP	○	
20	INDICATOR LAMP	○	
21	INDICATOR LAMP	○	
22	INDICATOR LAMP	○	
23	INDICATOR LAMP	○	
24	INDICATOR LAMP	○	
25	INDICATOR LAMP	○	
26	INDICATOR LAMP	○	
27	INDICATOR LAMP	○	
28	INDICATOR LAMP	○	
29	INDICATOR LAMP	○	
30	INDICATOR LAMP	○	
31	INDICATOR LAMP	○	
32	INDICATOR LAMP	○	
33	INDICATOR LAMP	○	
34	INDICATOR LAMP	○	
35	INDICATOR LAMP	○	
36	INDICATOR LAMP	○	
37	INDICATOR LAMP	○	
38	INDICATOR LAMP	○	
39	INDICATOR LAMP	○	
40	INDICATOR LAMP	○	
41	INDICATOR LAMP	○	
42	INDICATOR LAMP	○	
43	INDICATOR LAMP	○	
44	INDICATOR LAMP	○	
45	INDICATOR LAMP	○	
46	INDICATOR LAMP	○	
47	INDICATOR LAMP	○	
48	INDICATOR LAMP	○	
49	INDICATOR LAMP	○	
50	INDICATOR LAMP	○	
51	INDICATOR LAMP	○	
52	INDICATOR LAMP	○	
53	INDICATOR LAMP	○	
54	INDICATOR LAMP	○	
55	INDICATOR LAMP	○	
56	INDICATOR LAMP	○	
57	INDICATOR LAMP	○	
58	INDICATOR LAMP	○	
59	INDICATOR LAMP	○	
60	INDICATOR LAMP	○	
61	INDICATOR LAMP	○	
62	INDICATOR LAMP	○	
63	INDICATOR LAMP	○	
64	INDICATOR LAMP	○	
65	INDICATOR LAMP	○	
66	INDICATOR LAMP	○	
67	INDICATOR LAMP	○	
68	INDICATOR LAMP	○	
69	INDICATOR LAMP	○	
70	INDICATOR LAMP	○	
71	INDICATOR LAMP	○	
72	INDICATOR LAMP	○	
73	INDICATOR LAMP	○	
74	INDICATOR LAMP	○	
75	INDICATOR LAMP	○	
76	INDICATOR LAMP	○	
77	INDICATOR LAMP	○	
78	INDICATOR LAMP	○	
79	INDICATOR LAMP	○	
80	INDICATOR LAMP	○	
81	INDICATOR LAMP	○	
82	INDICATOR LAMP	○	
83	INDICATOR LAMP	○	
84	INDICATOR LAMP	○	
85	INDICATOR LAMP	○	
86	INDICATOR LAMP	○	
87	INDICATOR LAMP	○	
88	INDICATOR LAMP	○	
89	INDICATOR LAMP	○	
90	INDICATOR LAMP	○	
91	INDICATOR LAMP	○	
92	INDICATOR LAMP	○	
93	INDICATOR LAMP	○	
94	INDICATOR LAMP	○	
95	INDICATOR LAMP	○	
96	INDICATOR LAMP	○	
97	INDICATOR LAMP	○	
98	INDICATOR LAMP	○	
99	INDICATOR LAMP	○	
100	INDICATOR LAMP	○	

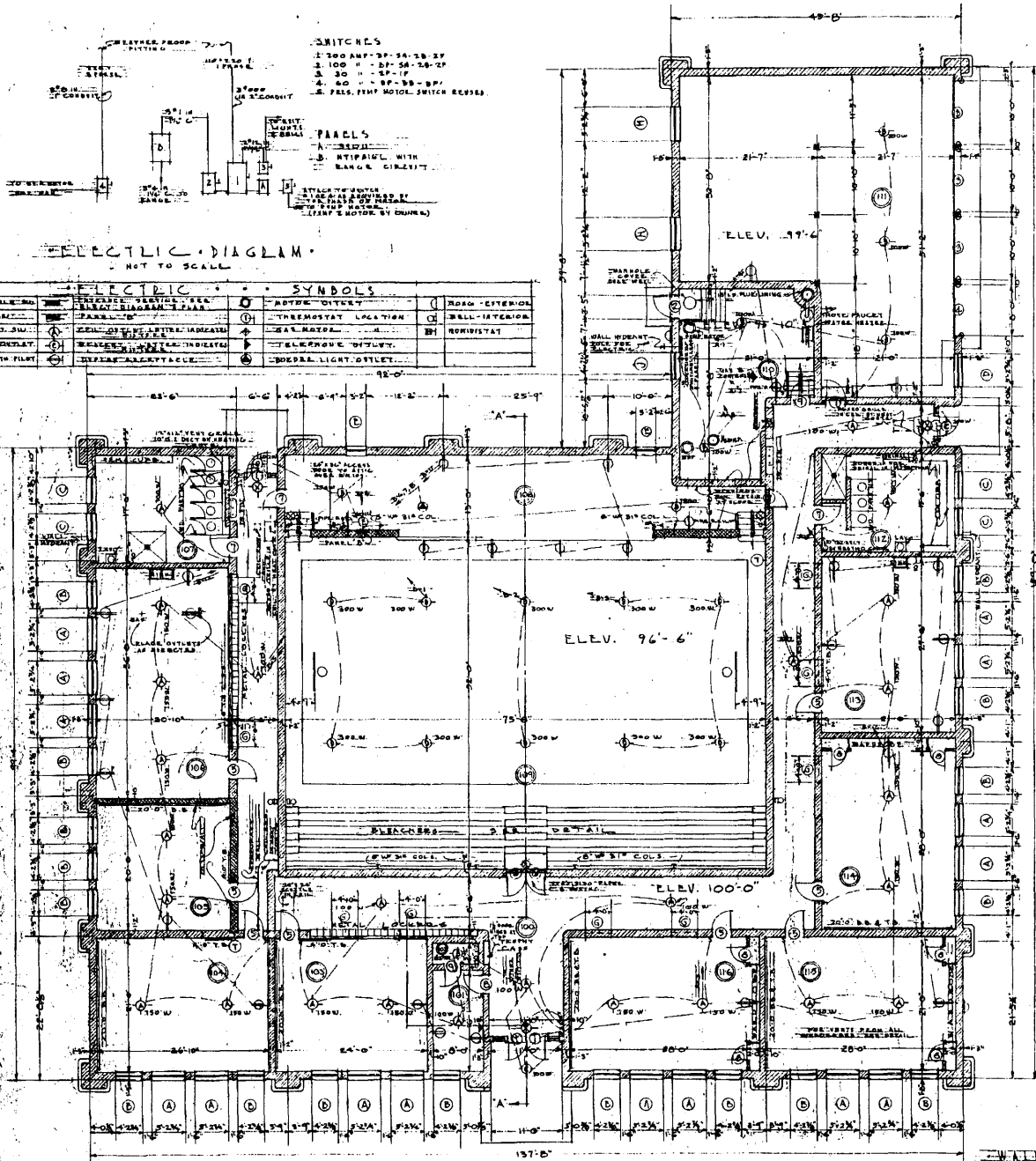

FIRST FLOOR PLAN
SCALE 1/8" = 1'-0"

NO.	NAME OF ROOM	PLUMB	ELECTRICAL	MECHANICAL	HEATING	VENTILATION	REF.	NO.	NO.
100	CORRIDOR								
101	OFFICE								
102	VAULT								
103	RECEPTION ROOM								
104	COMMERCIAL KITCHEN								
105	LECTURE HALL								
106	BOILER & CLOTHING ROOM								
107	GIRLS TOILET & SHOWER								
108	BOYS TOILET & SHOWER								
109	STAIR								
110	RESTROOM								
111	SUPPLY ROOM								
112	BOYS TOILET & SHOWER								
113	MANUAL TRAINING ROOM								
114	CLASS ROOM								
115	CLASS ROOM								
116	CLASS ROOM								

DOOR SCHEDULE

NO.	DESCRIPTION
1	WOOD DOOR - 2 1/2\"/>

WINDOW SCHEDULE

NO.	DESCRIPTION
A	UNIT 1 - 2\"/>

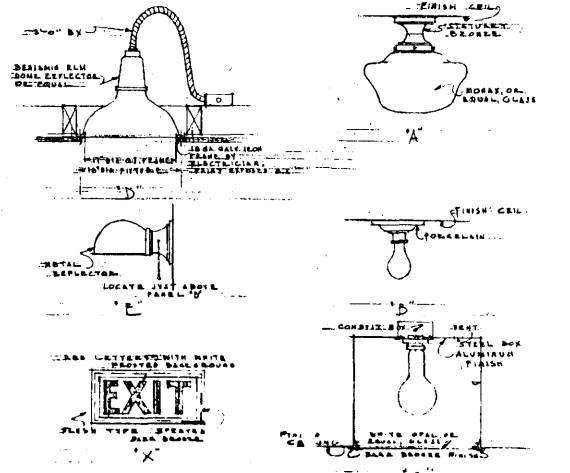

ELECTRIC FIXTURES
NOT TO SCALE
SIZE OF FIXTURES DETERMINED BY SIZE OF LIGHTS REQUIRED

WALL INDICATIONS
BUILDING TILE - SECOND SECTION
CONCRETE WALLS - FIRST SECTION
CONCRETE WALLS - SECOND SECTION
ADOBY WALLS - FIRST SECTION
ADOBY WALLS - SECOND SECTION
FRAME WALLS - FIRST SECTION
FRAME WALLS - SECOND SECTION

SCHOOL BUILDING FOR
BR. CONSOLIDATED SCHOOL DISTRICT NO. 3507
COUNTY, KANSAS
WATER KANSAS
AANN AND COMPANY ARCHITECTS & ENGINEERS
1427 HUTCHINSON KANSAS

United States Department of the Interior
National Park Service

National Register of Historic Places
Continuation Sheet

Section: 9-10 & Additional Documentation Page: 16

Historic Public Schools of Kansas
Shallow Water School, Scott County, Kansas

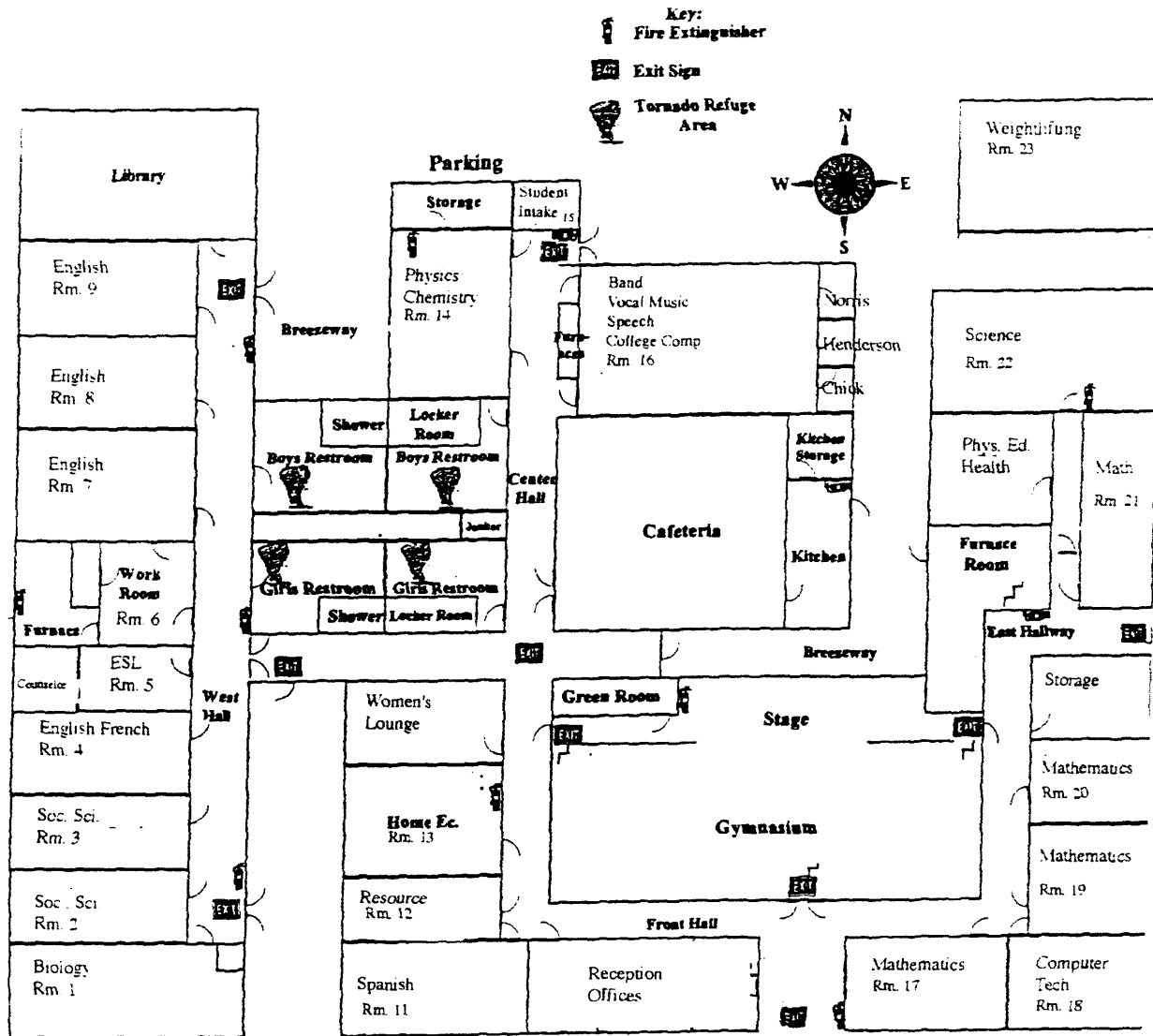

Scott Community High School
at
Shallow Water School

Figure 3 – Plan/Layout of Existing School.