

United States Department of the Interior  
National Park Service

5C-1852

# National Register of Historic Places Registration Form

This form is for use in nominating or requesting determinations for individual properties and districts. See instructions in National Register Bulletin, *How to Complete the National Register of Historic Places Registration Form*. If any item does not apply to the property being documented, enter "N/A" for "not applicable." For functions, architectural classification, materials, and areas of significance, enter only categories and subcategories from the instructions.



### 1. Name of Property

Historic name: Shiloh Baptist Church

Other names/site number: DHR No. 259-0162-0007

Name of related multiple property listing:

N/A

(Enter "N/A" if property is not part of a multiple property listing)

### 2. Location

Street & number: 304 East Marshall Street

City or town: Middleburg State: VA County: Loudoun

Not For Publication:  n/a Vicinity:  n/a

### 3. State/Federal Agency Certification

As the designated authority under the National Historic Preservation Act, as amended,

I hereby certify that this x nomination     request for determination of eligibility meets the documentation standards for registering properties in the National Register of Historic Places and meets the procedural and professional requirements set forth in 36 CFR Part 60.

In my opinion, the property x meets     does not meet the National Register Criteria. I recommend that this property be considered significant at the following level(s) of significance:

    national     statewide   x   local

Applicable National Register Criteria:

  x   A     B   x   C     D

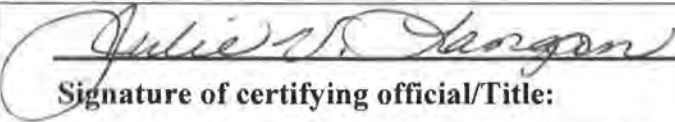
	<u>10-9-17</u>
<b>Signature of certifying official/Title:</b>	<b>Date</b>
<u>Virginia Department of Historic Resources</u>	
<b>State or Federal agency/bureau or Tribal Government</b>	

In my opinion, the property <u>   </u> meets <u>   </u> does not meet the National Register criteria.	
<b>Signature of commenting official:</b>	<b>Date</b>
<b>Title :</b>	<b>State or Federal agency/bureau or Tribal Government</b>

Shiloh Baptist Church  
Name of Property

Loudoun County, VA  
County and State

**4. National Park Service Certification**

I hereby certify that this property is:

- entered in the National Register  
 determined eligible for the National Register  
 determined not eligible for the National Register  
 removed from the National Register  
 other (explain:)

*Patrick Andrews*  
Signature of the Keeper

*11/24/2017*  
Date of Action

**5. Classification**

**Ownership of Property**

(Check as many boxes as apply.)

- Private:   
Public – Local   
Public – State   
Public – Federal

**Category of Property**

(Check only **one** box.)

- Building(s)   
District   
Site   
Structure   
Object

Shiloh Baptist Church  
Name of Property

Loudoun County, VA  
County and State

**Number of Resources within Property**

(Do not include previously listed resources in the count)

Contributing	Noncontributing	
<u>0</u>	<u>0</u>	buildings
<u>0</u>	<u>0</u>	sites
<u>1</u>	<u>0</u>	structures
<u>1</u>	<u>0</u>	objects
<u>2</u>	<u>0</u>	Total

Number of contributing resources previously listed in the National Register 1

---

**6. Function or Use**

**Historic Functions**

(Enter categories from instructions.)

RELIGION: Religious Facility: Church

---

---

---

---

---

---

**Current Functions**

(Enter categories from instructions.)

RELIGION: Religious Facility: Church

---

---

---

---

---

Shiloh Baptist Church  
Name of Property

Loudoun County, VA  
County and State

---

## 7. Description

### Architectural Classification

(Enter categories from instructions.)

LATE 19<sup>th</sup> AND 20<sup>th</sup> CENTURY REVIVALS: Late Gothic Revival

---

---

---

---

---

---

**Materials:** (enter categories from instructions.)

Principal exterior materials of the property: STUCCO; STONE; METAL

### Narrative Description

(Describe the historic and current physical appearance and condition of the property. Describe contributing and noncontributing resources if applicable. Begin with a **summary paragraph** that briefly describes the general characteristics of the property, such as its location, type, style, method of construction, setting, size, and significant features. Indicate whether the property has historic integrity.)

---

### Summary Paragraph

Shiloh Baptist Church (DHR No. 259-0162-0007) is located at 304 East Marshall Street in the Town of Middleburg in southwest Loudoun County, Virginia. The site includes the church (contributing building), an original wrought iron fence (contributing object) and a stone wall (contributing structure). Constructed in 1913 on .11 acre, Shiloh Baptist exhibits vernacular building traditions constructed with Gothic Revival-style detailing with its pyramidal louvered belfry, rosette, and pointed-arch frame topped windows. The church is a one-story rectangular block building sitting on a raised basement with a continuous stone and concrete foundation. The building features an entry nave or vestibule as the front façade, which is topped with a slightly lower front gable roof with the centered louvered belfry. The primary entrance is located along the west wall of the nave and another secondary entrance is centered on the façade providing access to the lower level fellowship hall. The building faces south on a well-maintained small grassy lot only one block from Middleburg's Main Street. The church remains relatively unaltered in form and mass. The original stone walls were covered in stucco, probably in the 1950s. Despite this change the church retains a high degree of integrity of location, design, setting, materials, workmanship, and association. Shiloh Baptist Church is located within the Middleburg Historic District (NRHP 1982) and is a contributing resource to the district.

Shiloh Baptist Church  
Name of Property

Loudoun County, VA  
County and State

---

## Narrative Description

### Setting

Shiloh Baptist Church is situated in a predominately residential neighborhood on the north side of East Marshall Street on a small town lot in Middleburg. The small grassy lawn around the building is landscaped with a variety of ornamental trees and bushes and enclosed by a decorative wrought iron fence (contributing object). A stone wall (contributing structure) marks the eastern boundary of the property. A paved driveway extends past the west side of the building to the site of the former parsonage and a parking lot shared with the adjacent community center.

### Church (Contributing Building)

#### *Exterior*

Shiloh Baptist Church is a two-story, three-bay, rectangular block building covered by a metal front gable roof with a two-story, hipped roof addition off the rear elevation. The building sits on its original coursed stone foundation. The church design is a vernacular adaptation of the Gothic Revival Style with pointed arched framing topping most of the windows, overhanging eaves and exposed rafters. The church was originally constructed of stone but received stucco covering in the 1950s. The projecting front gable is topped with a tall, stucco clad squared belfry with a pyramidal, copper clad roof. The belfry or tower features a louvered vent framed by a pointed arched opening. Most of the windows are original but the lights have been replaced with multi-colored frosted panes. The openings along the second story, on all elevations, are wide double-hung eight-over-eight windows with the same multi-colored frosted panes as the rest of the windows. They are all topped by a fixed pointed arched frame. All of the windows on the first story or lower level are replacement vinyl windows made to mimic the original eight-over-eight windows. Simple wood trim frames each of the lower level windows on the east and west elevations. The lower level windows on the front elevation contain the same simple wooden frames as those on the other elevations but are topped with a framed outline of the pointed arched found above the second story windows. Additional openings on the façade include an oculus centered on the front gable, and a small fixed window on the lower level provides light to a small storage area. The small window is also topped with a framed pointed arch. The façade also features a double-door entry at the lower level providing access to the church's fellowship hall. The entry is framed by a simple wood trim and simple, unadorned, narrow transom. There is a date stone located on the lower left corner of the façade that reads "Shiloh Bapt Church" Rebuilt Sept 28, 1913."

The main entry is located on the west elevation and is accessed via a wide concrete sidewalk which leads up seven concrete steps, topped with stone pavers, to a large and tall wooden multi-paneled double-door. The steps are framed by simple iron railings. The door's framework includes simple wood trim painted white and is topped by a large fourteen light pointed arched window with multi-colored panes. The rest of the east elevation includes four large windows on

Shiloh Baptist Church  
Name of Property

Loudoun County, VA  
County and State

the second story and four replacement windows on the first story. On the west elevation of the rear addition is another entry leading to a storage area at the back of the fellowship hall. At the second story level is a small six-over-six window, framed with simple wood trim that lights the Preacher's office. The east elevation is similar in fenestration to the west elevation with the exception of a four-paneled sunken entryway that leads to a small room where the furnace was originally located.

The rear elevation has five openings, two lower level windows, one original six-over six, double hung window with multi-colored panes and a large window that has been covered except for the pointed arched transom above. A small louvered vent can be seen on the end gable. The rear addition also features a small interior brick chimney between the rear of the original rectangular block and the addition.

### *Interior*

The interior of the church retains its original layout and many of its original details. The main entry on the west elevation leads to an inner vestibule. The vestibule provides access to the sanctuary and houses a half-landing stairway along the east wall. The stairs feature a dark-stained wood banister with square newel posts. The staircase provides access to the fellowship hall, the restrooms, and the kitchen on the lower level. Centered on the vestibule's north wall is a paneled double-leaf entry door providing access to the sanctuary. The doors have four raised panels and one inserted glass panel allowing sight into the sanctuary. The walls of the vestibule are covered with beadboard wainscoting and a modern chandelier hangs from the ceiling near a small square access panel to the belfry. The plaster walls of the vestibule are painted white and the original wood floors are covered by carpet. The trim around the windows and doors is simple and stained to match the rest of the interior trim on all the windows and doors found in the church.

### *Sanctuary*

The Sanctuary features its original plaster ceiling along with suspended vintage chandeliers above the centered set of pews. Contemporary wall sconces line the east and west walls to provide additional light. The sanctuary walls retain original, painted plaster. The east and west walls each feature three, eight-over-eight double hung windows with replacement multi-colored lights. The windows are framed with the same dark-stained pine trim as found throughout the church around other doors and windows. The modern pews are arranged in three sections with nine down the center and rows of ten along the east and west walls. The arrangement of the pews allows for two aisles that lead to the chancel and choir area of the church. The chancel and choir areas are raised and delineated by two large arched openings. The center opening features the chancel area where the rear wall features a decorated wood paneling that frames a centered six-panel oculus window with multi-colored panes. The beadboard wainscoting continues and is interrupted only by the wood panel and another door leading to the rear of the church and the pastor's office. Presumably this entry is for the pastor to enter the chancel during services. The choir area features another rear window and the same beadboard wainscoting as the rest of the

Shiloh Baptist Church  
Name of Property

Loudoun County, VA  
County and State

church. Along the west wall is a third arch that has been closed in and now contains a door leading to the rear of the church. The entire sanctuary features its original pine or oak flooring while the aisles have been covered in traditional red carpeting.

#### *Rear Addition - Pastor's Office and Baptismal*

The Pastor's Office is a small room in the rear addition accessed from the sanctuary and through a wood two-panel pine door with simple trim. The walls are painted white and feature a picture rail that extends around most of the room. The original baptismal pool is located in the hallway just outside of the pastor's office directly behind the wall of the chancel area. It is accessed through a trap door in the floor.

#### *Lower Level- Fellowship Hall*

The Fellowship Hall is located on the first story and accessed via a wood staircase in the vestibule or via a staircase in the rear addition. In the vestibule there is small vertical panel door that leads to a crawl space under the stairs. The space is used for storage. The lower level vestibule leads to a small landing with bead board wainscoting, painted white walls and along the west wall is the entrance to the men's bathroom. Another short set of stairs leads down into the hall through a set of modern French doors. The ladies' restroom is located on the west wall just before entering the hall. Both restrooms contain their original five vertical panel wood doors. The floor of the small landing is covered in carpet that extends down the short flight of stairs. The fellowship hall floor is covered in linoleum. The large room features a series of support posts down the center and its original plaster walls except towards the rear where some paneling has been installed. Along the southeast wall is a small modern kitchen and towards the rear of the hall two steps lead to a small carpeted area and the entrance to the rear addition, another set of stairs leading back up to the pastor's office and the baptismal and the sanctuary.

#### *Rear Addition - First Story*

Found on the first story of the rear addition is another set of stairs that lead up to the Pastor's office. The rear first story also features several storage closets and a rear exit along the west wall that provides egress to the west lawn area and the site of the former parsonage. A single replacement window provides light into the hallway leading to the exit. Along the east wall is another room used for meeting space and other church activities.

Shiloh Baptist Church  
Name of Property

Loudoun County, VA  
County and State

---

## 8. Statement of Significance

### Applicable National Register Criteria

(Mark "x" in one or more boxes for the criteria qualifying the property for National Register listing.)

- A. Property is associated with events that have made a significant contribution to the broad patterns of our history.
- B. Property is associated with the lives of persons significant in our past.
- C. Property embodies the distinctive characteristics of a type, period, or method of construction or represents the work of a master, or possesses high artistic values, or represents a significant and distinguishable entity whose components lack individual distinction.
- D. Property has yielded, or is likely to yield, information important in prehistory or history.

### Criteria Considerations

(Mark "x" in all the boxes that apply.)

- A. Owned by a religious institution or used for religious purposes
- B. Removed from its original location
- C. A birthplace or grave
- D. A cemetery
- E. A reconstructed building, object, or structure
- F. A commemorative property
- G. Less than 50 years old or achieving significance within the past 50 years



Shiloh Baptist Church  
Name of Property

Loudoun County, VA  
County and State

**Areas of Significance**

(Enter categories from instructions.)

ETHNIC HERITAGE: African American  
ARCHITECTURE

\_\_\_\_\_  
\_\_\_\_\_  
\_\_\_\_\_  
\_\_\_\_\_

**Period of Significance**

1913-1967

\_\_\_\_\_  
\_\_\_\_\_

**Significant Dates**

1913

\_\_\_\_\_  
\_\_\_\_\_

**Significant Person**

(Complete only if Criterion B is marked above.)

N/A

\_\_\_\_\_  
\_\_\_\_\_

**Cultural Affiliation**

N/A

\_\_\_\_\_  
\_\_\_\_\_

**Architect/Builder**

Hall, Nathan Nathaniel

\_\_\_\_\_  
\_\_\_\_\_

Shiloh Baptist Church  
Name of Property

Loudoun County, VA  
County and State

**Statement of Significance Summary Paragraph** (Provide a summary paragraph that includes level of significance, applicable criteria, justification for the period of significance, and any applicable criteria considerations.)

Shiloh Baptist Church is locally significant and eligible for the National Register of Historic Places under *Criterion A, Ethnic Heritage: African American*, for its role in the history of African Americans living in Middleburg, Virginia, during the tumultuous years of Jim Crow segregation and the Civil Rights era. It is also significant for its association with Middleburg's diverse history, specifically the freed African American community who built and supported the church and congregation. Loudoun County's sociopolitical context of slavery, war, Reconstruction, disenfranchisement, Jim Crow, Great Depression, outmigration and desegregation limited the growth and development of its African American citizenry and the church offered members of the community an alternative to the larger and harsher reality that surrounded them. While freedom came to African Americans, bitter resentment also came from local whites. Beyond providing refuge, the church offered opportunities in education, personal growth and an avenue for social engagement without discrimination. Shiloh Baptist Church is also locally significant under *Criterion C, Architecture*, as a good example of a vernacular adaptation of the Late Gothic Revival as envisioned by Master Stonemason, Nathan Nathaniel Hall, an African American and member of the church. The period of significance for Shiloh Baptist Church begins in 1913 with the construction of the new church on Marshall Street and ends in 1967, encompassing the eras of Jim Crow and Civil Rights as well as the traditional fifty-year cutoff for properties where significant activities have continued into the more recent past because it continues to serve and function as a church for the Middleburg community. The property meets *Criteria Consideration A* for religious properties because its significance is based on its architecture and the historical importance of the property in the area of Ethnic Heritage. Shiloh Baptist Church is located within the Middleburg Historic District (NRHP 1982) and is a contributing resource to the district.

---

**Narrative Statement of Significance** (Provide at least **one** paragraph for each area of significance.)

*Historic Context/Criterion A*

Shiloh Baptist Church, completed in 1913, is significant as witness to the social, political, educational, and architectural changes in Middleburg and Loudoun County's African American community. Many of Shiloh Baptist Church's leaders were also community leaders in the long struggle for equality and social justice. During the eras of Reconstruction, Jim Crow and Civil Rights, the church became one of the most important institutions in the lives of African Americans. In addition to meeting the religious needs of the congregation, it was the center of culture that provided avenues for education and social interaction and it served as a place of opportunity for growth and enrichment. It is also representative of the determination of the African American community in Middleburg and a symbol of the ongoing influence of its members in the effort to fight racial inequality.

Shiloh Baptist Church  
Name of Property

Loudoun County, VA  
County and State

Early in 1866, just after the Civil War and three years after Abraham Lincoln issued the Emancipation Proclamation in 1863, a Christian movement was taking place in Loudoun County and beyond. Before the Civil War, laws prohibited African Americans from meeting for worship on their own and there were few African American churches in Virginia. "Colored" preachers were only allowed to officiate in the presence of a white minister or a person assigned by the white minister to oversee the service. Even then, African American clergy were not permitted to enter the pulpit. In 1867, Reverend Leland Warring, an ex-slave, who had been teaching and ministering to escaped slaves in Alexandria and Brandy Station, Virginia, came to Loudoun County and soon determined a need for a church to serve recently freed slaves in Middleburg. Those blacks, who once had to sneak and "steal away" to hold prayer meetings or worship in the balcony of the local white Middleburg Baptist Church, were now encouraged to hold open meetings and establish their own churches. Rev. Leland Warring was known and respected among white ministers in Loudoun, Fauquier, and surrounding counties because of his abilities and wisdom.

Upon his arrival in Middleburg in 1867, Rev. Warring and a group of eight initial members organized and built Shiloh Baptist Church. "Old Shiloh" was located on a site just west of the Town of Middleburg. The church was a one-story, wooden frame, clapboard building with an unfinished basement, pitched roof, and bell tower. Rev. Warring served as Pastor of "Old Shiloh" for 20 years. During the tenure of Rev. Warring, nationally, the Freedman's Bureau was organized to provide relief and assistance to former enslaved individuals, including health services, educational services and abandoned land services. Increasingly, schools established by the Freedman's Bureau became inadequate, and local schools board found endless excuses not to improve them. Groups and institutions such as the Odd Fellows and Shiloh Baptist Church in Middleburg offered their facilities. This tradition of the African American community and churches providing actual school buildings and transporting students at their own expense lasted in Virginia until the 1940s. By Rev. Warring's retirement in 1887, Christian teaching, learning and fellowship had become deeply rooted in the hearts of the Shiloh congregation; hence, they immediately desired to have a successor who would continue the work of the Lord and continue to lead the congregation through a time of freedom, yet help combat and provide relief during a new era and a new type of repression.

On April 25, 1887, Reverend Richard P. Dawson became Shiloh's second pastor. For 46 years, the original Shiloh Baptist Church served the congregation until the eve of the First World War when, under Rev. Dawson's leadership, the present building was constructed at 304 East Marshall Street in the Town of Middleburg. The land for the new church was deeded to the Board of Trustees in 1911 by Wesley and Mary Wanzer, a local African American couple. The original church building, which became the home of the late Shiloh Baptist Church deacon and longtime employee of the Middleburg Community Center Peter Tibbs, continues to be the home where his widow and current member of Shiloh Baptist Church, Mrs. Elaine Tibbs, resides.

Rev. Dawson, also an educator, lived in the community and served as Pastor until his death in 1921. Reverend Sylvester Walker, from Harrisonburg, VA, became Shiloh's third Pastor. Reverend Walker is noted for his infamous baptism of eight African American convicts which

Shiloh Baptist Church  
Name of Property

Loudoun County, VA  
County and State

over 500 people attended. After Rev. Walker left the congregation, George W. Coleman became Shiloh's pastor. He is attributed with starting the Usher Board, the Missionary Society, and the first Junior Choir. In 1933, Reverend William C. Chambers was called as Shiloh's fifth pastor and he served for six years until his death in 1939. The 1940s also would be a time of growth for the small church.

From around 1913-1954, institutional terrorism commonly known as Jim Crow was active in Loudoun County as well as throughout Virginia and many other states. During this era, white people felt a need to gain more control over black people. Numerous new laws were passed restricting the freedoms of African Americans, from the right to vote to the train cars they were allowed to ride in to the kinds of jobs available to them. African Americans generally were not threatened as long as they stayed in "their place" and did not upset the status quo. They faced the challenge of surviving in a society where white supremacy ruled. The more oppressive life became, the more African Americans saw the need to come together. Consequently, they formed several organizations, such as the National Association for the Advancement of Colored People (NAACP), that still exist today. While each neighborhood was unique, the common threads that joined them were the lack of adequate educational opportunity and the denial of civil rights. During this tumultuous time, Shiloh Baptist continued its mission and continued to grow and support the community. The Deacon Board increased in size and the Men's Club and Women's Auxiliary became important to the congregation and the greater African American community. It also was during this time that the Trustees of the Church, for the first time, registered with the Loudoun County Court.

During the Jim Crow era the church became an important place for cultivating leaders and entrepreneurs and launching civil rights movements as well as providing spiritual, emotional, educational, and mutual aid. In 1940, Shiloh Baptist Church hosted the first countywide "Negro History Week," sponsored by the County-Wide League. The County-Wide League was established by John Wesley Wanzer, an active member of Shiloh Baptist Church. John Wesley Wanzer was one of Loudoun County's most successful businessmen and remembered as one who had the strength of his convictions. He was a welder/blacksmith, owner of John Wanzer Blacksmith and Wheelwright, member of the Loudoun County NAACP and a trustee of the Aberdeen Lodge of the Grand United Order of Odd Fellows. John Wesley Wanzer served as the chairman of the Deacon Board and the superintendent of the Sunday School for 39 years. He also served as the moderator of the Northern Virginia Baptist Sunday School Union and as the Corresponding Secretary of the Northern Virginia Baptist Association. During his lifetime, he was known by most African Americans in Loudoun County.

Although he and his wife (Frances Hall Wanzer) had no children, John Wesley Wanzer was deeply concerned about inequalities in education among blacks and whites. It was reported that "the thing that bothered him most was seeing half empty busloads of white children crisscrossing the county while African American students were provided no transportation at all."<sup>1</sup> In 1928, he became the president of the County-Wide League, an organization dedicated to pursuing equal

---

<sup>1</sup> The Essence of the People, May 2001, Pgs. 63-65

Shiloh Baptist Church  
Name of Property

Loudoun County, VA  
County and State

educational opportunities for African American students in the Loudoun County public schools. He held this position throughout the life of the organization.

For years, his blacksmith business was the only one of its kind in Middleburg. In 1939, when Wanzer and the members of the County-Wide League Board of Trustees attempted to purchase land to build a high school for blacks, his predominantly white clientele boycotted his business and the jobs of two other members of the League were threatened. Such economic threats were commonly faced by African Americans who organized for civil rights during this time.

The mission of the League was to obtain equal educational opportunities for African American students in the public schools of Loudoun County. The County-Wide League was governed by a board of trustees who presented requests for improvement to the Loudoun County School Board, which generally took no action. In 1939, Wanzer, in his capacity as President of the League, along with the board of trustees hired a Washington DC-based attorney who helped the African American community to organize a branch of the NAACP. The Loudoun County NAACP received its charter in 1940. During the first Negro History Week in 1940, speaker Charles Houston, Dean of the Howard University School of Law, spoke on the unacceptable conditions at black schools, lack of equipment, insufficient bus transportation, and unequal pay.<sup>2</sup> In 1948, Shiloh Baptist Church, as it had in its earliest days, offered use of its building to be used as a school. It was used to accommodate the overflow of the first and second grade African American students whose numbers now exceeded the space at the nearby Marble Quarry School.

While education was the African American community's main concern, it was not the only area of life affected by Jim Crow segregationist policies. Other than teachers, few African American professionals settled in Loudoun County. Doctors were denied privileges at Loudoun Memorial Hospital. A Purcellville businessman had to sue before "public" libraries allowed him access. The Leesburg Volunteer Fire Department filled in and paved over its "public" swimming pool and closed its ball field rather than permit African Americans to use the facilities. It took much courage for African Americans to live in Middleburg and Loudoun County during this era. Churches, like Shiloh, provided a stable center for social interaction and peaceful organization.

Throughout Shiloh's history many members of its congregation became important leaders in the fight for equality. Rosa Lee Carter (b.1909-d.1999), a Shiloh Baptist Church member, became an active member in the community as an educator and community affairs contact in the Middleburg area. Ms. Carter was born in West Virginia, attended Storer College in Harpers Ferry and settled in Loudoun County, where she began her teaching career. Ms. Carter was considered the "Mother of the Church" and was known as the person to contact when members of the community needed advice and help dealing with government officials during the oppressive regulations of Jim Crow. She has been identified as an important woman in Loudoun County history and the County's newest elementary school was named in her honor. Another prominent African American, William McKinley Jackson (b. 1900-d.1970) was a stonemason and became known as Middleburg's "no nonsense" contractor for his belief in equality for every

---

<sup>2</sup> Timeline of Important Events in African American History in Loudoun County, Virginia by Eugene Scheel. <http://www.loudounhistory.org/history/african-american-chronology.htm>. Accessed 5/19/17

Shiloh Baptist Church  
Name of Property

Loudoun County, VA  
County and State

man, woman, and child regardless of race, color, or creed along with his tireless efforts to improve race relations. He was also an advocate of the best education for all. From his early beginning as a stonemason with a fourth-grade education, Jackson rose to become a successful building contractor, president of the Loudoun County branch of the NAACP and an active member of the County Wide League's early efforts to achieve equal schooling for African American children. He also led efforts to integrate public places in Middleburg such as the public swimming pool, the Middleburg Community Center, and the public library. On the 25<sup>th</sup> anniversary of the Loudoun County NAACP's founding, Jackson desegregated the Middleburg Community Center by simply, yet directly, establishing the NAACP's need to use the facility. In 1962, he was involved in bringing a suit against the school board to integrate the Loudoun County schools; however, the order to desegregate was not fully obeyed. Twelve African American students had asked to be admitted to white high schools; only four were admitted. As president of the County's NAACP chapter, Mr. Jackson worked with the Department of Justice to get the School Board to comply. In 1967, the NAACP went back to court and, ultimately, the order of the court was honored with full desegregation of county schools.

In addition to his long service with the NAACP, William McKinley Jackson was a charter member of Head Start, member of the Board of the Solon Cemetery for Blacks, member of the Odd Fellows, and an active member of Shiloh Baptist Church (Middleburg). At Shiloh, he served as chairman of the Deacon Board. Deacon Jackson was viewed as a serious and imposing individual. Reportedly, "when he was dressed for his Sunday morning service, he would walk like a soldier." And woe be it to the individual who did not appreciate the Deacon's insistence on punctuality. There is an account regarding a minister whom Deacon Jackson engaged as a guest preacher at Shiloh. The minister arrived late. Deacon Jackson greeted him and said, "You will have to come another time. The service is over!"<sup>3</sup>

During the Civil Rights era, Shiloh Baptist and its members continued to play an important role in the lives of African Americans living in and around Middleburg. Although the 1875 Civil Rights Act sought to guarantee African-Americans full equality, the legislation became little more than words as African Americans were still subjected to brutal racial oppression in Virginia and throughout the South almost one hundred (100) years after the end of the Civil War.<sup>4</sup> The 20<sup>th</sup> century Civil Rights movement, however, was committed to ending racial segregation and discrimination against African Americans and securing legal recognition and federal protection of their citizenship rights. During this era, in Washington, DC, the civil rights movement was gaining momentum and soon moved into Loudoun County, Middleburg, and other parts of Virginia. The NAACP filed more lawsuits in Virginia more than in any other state. Virginia had perhaps the strongest group of civil rights and NAACP fighters than were seen of any state in the Union, which proved to be revolutionary in changing the political climate throughout the state.

In the beginning years of the Civil Rights era, the fight and emphasis was still on equality in education and how education could lead to a better life. It was in a climate such as that described

<sup>3</sup> The Essence of a People, May 2001, Pg. 37

<sup>4</sup> Grigsby, Kevin Dulany, *From Loudoun to Glory: The Role of African Americans from Loudoun County in the Civil War*, 2012, pg. 56

Shiloh Baptist Church  
Name of Property

Loudoun County, VA  
County and State

by Scheel that prompted a 1950 meeting of the local branch of the NAACP that was held at Shiloh Baptist Church. The organization asked that all Loudoun County students currently enrolled in colleges and universities participate and encouraged them to discuss their majors or fields of interest. Speeches were given on "Preparation for Successful Living."<sup>5</sup> This demonstrated to the younger generation that education beyond what they knew in Middleburg and Loudoun County was attainable and could lead to better opportunities. The church was one of the few places African Americans could congregate and discuss opportunities like those discussed during this meeting.

In an account provided by Eugene Scheel entitled, "The Civil Rights Movement in Middleburg, Virginia," he describes life in Loudoun County and Middleburg during the early 1960s. He asserts as follows:

*"Loudoun County had more than twice the percentage of blacks (18% of the county's 24,549 residents) than today. According to the demographic data provided by the Loudoun County Zoning and Planning Division (dated June 2014), blacks represented 7.8% of the county's residents; however, during the 20<sup>th</sup> century civil rights era, they were more racially segregated. Other than a few churches where blacks worshipped with whites, the few integrated facilities in Loudoun County were the public library in Purcellville. The Board of Supervisors in 1956 threatened to withhold money from schools that integrated, hence, until 1968, schools were completely segregated."*

In 1961 NAACP President William McKinley Jackson, deacon at Shiloh Baptist Church, was asked by a group of Howard University students to organize a sit-in demonstration at a local drugstore and three of Middleburg's other restaurants. At the time, the town had very few restaurants open to the African American community. The plan, hailed as "Confrontation Sunday," would take place during the same time President John F. Kennedy was attending Mass at the nearby Middleburg Community Center. Prior to the meeting McKinley contacted Reverend Albert Pereria, who would be preaching during the President's visit. Pereria was against segregation and asked for a meeting to be held with restaurant owners and other leaders in the community. The meeting was held on the Saturday prior to the proposed sit-in and during that meeting two African Americans were served at Flournoy's Drugstore. The next day Reverend Pereria closed his homily with "Let us pray together today that understanding and love may exist between races, and that from now on, the area of communications be broadened so that Negroes will have the opportunity to become first-class citizens."<sup>6</sup> The success of this "threat" of a sit-in prompted Howard students to continue their fight in Loudoun County and beyond.

Another member of the congregation, Charles "Jack" Turner, deacon at Shiloh, was a contractor and brick mason. In November 1967, he was among the first two African Americans to hold a local elected office. He served on the Town Council, was a member of the County-Wide League and served as a member of the Masonic Temple. From 1967 until 1969, the period when integration occurred in Loudoun County, Mr. Turner was a member of the Benjamin Banneker

<sup>5</sup> Crisis, NAACP Publication, 1950 "Current Events"

<sup>6</sup> Scheel, Civil Rights Movement in Middleburg Virginia

Shiloh Baptist Church  
Name of Property

Loudoun County, VA  
County and State

Parent Teacher Association and protested against the Loudoun County School's District's demotion of the four black principals in the wake of desegregation. In 1968, Turner protested against the County's effort to rename the Benjamin Banneker<sup>7</sup> School to that of Mercer School when, due to integration, the school would be serving the predominately white residents from the Mercer District. Mr. Turner is another example of the leadership provided by Shiloh Baptist and its members to the greater African American community of Middleburg.

Shiloh Baptist continued to serve the Middleburg community, providing leadership and fellowship throughout the rest of the Civil Rights era. It continues today as a prominent church in the Town, continuing to provide for its congregation and the community.

### *Architectural Discussion/Criterion C*

Shiloh Baptist Church is locally significant under *Criterion C* in the area of Architecture as a vernacular adaptation of the Late Gothic Revival, a style that continued in popularity, especially with ecclesiastical architecture, into the early 20<sup>th</sup> century. The style is noted for its pointed arched windows, steeply pitched roofs, front gables with tracery or vergeboard, and centered castellated towers. As an example of a restrained adaptation of Late Gothic Revival, Shiloh Baptist exhibits the style with use of pointed arched framing above each window, overhanging eaves and exposed rafters on its west and east elevations, and a louvered pointed arch opening on its bell tower.

Loudoun County contains only a small number of documented, intact African American Gothic Revival-style churches. Earlier Gothic Revival examples are found throughout the region, for example Grace Methodist Church (DHR# 053-0205), built of stone near Lincoln, is an earlier adaptation of Late Gothic Revival and was also constructed for and by African Americans. Another later example is the Mt. Olive Methodist Episcopal Church (DHR# 053-0994) located outside of Leesburg. It is a Late Gothic Revival-style church with a front gable roof and a stone foundation and, like Shiloh Baptist, has a front projecting vestibule. The church was constructed in 1890, 23 years before Shiloh was constructed. It is a smaller building representative of a more rural setting, similar to what the original or "Old Shiloh" church looked like prior to construction of the 1913 church building. The new Shiloh Baptist Church is larger in mass and more substantial in height and ornamentation, demonstrating monumentality and permanence for the church's new location in town.

The church is also significant because the property represents the work of Nathan Nathaniel Hall and his son William Nathaniel Hall, master stonemasons and members of one of very few

---

<sup>7</sup> Benjamin Banneker (1731-1806) was an author, scientist, mathematician, farmer, astronomer, publisher and urban planner. In 1791, Banneker accompanied Major Andrew Ellicott to the banks of the Potomac to assist him in surveying Washington DC. The SW-9 Intermediate Boundary Stone Banneker laid in Arlington County in 1791 was one of 40 stones the men placed. The Arlington County marker was designated a National Historic Landmark in 1976.



Shiloh Baptist Church  
Name of Property

Loudoun County, VA  
County and State

prominent African American families in Loudoun County during the late 19<sup>th</sup> century.<sup>8</sup> The Halls lived in Brown's Corner, a hamlet one-quarter mile east of Middleburg in a typical antebellum stone house originally built for a white owner in western Loudoun County. William Nathaniel Hall became known as Loudoun County's most prominent African American builder and established W.N. Hall and Sons. Other buildings constructed by the Halls include Middleburg National Bank, a wing at Loudoun County Hospital and the reconstructed George Washington Gristmill in Fairfax County.

---

<sup>8</sup> Eugene Scheel, "Brown's Corner: a 4-House Huddle," Loudoun Times Mirror, 22 July 1978.

Shiloh Baptist Church  
Name of Property

Loudoun County, VA  
County and State

---

## 9. Major Bibliographical References

### Bibliography (Cite the books, articles, and other sources used in preparing this form.)

Black History Committee of the Friends of the Thomas Balch Library, *The Essence of a People: Portraits of African Americans Who Made a Difference in Loudoun County, I and II Virginia*. Leesburg, Va.: Friends of the Thomas Balch Library, 2001, 2002.

Bradley, David. The Historic Murder Trial of James Crawford: Charles H. Houston, the NAACP and the Case That Put All-White Southern Juries on Trial. Jefferson, N.C.: McFarland, 2014.

Hahn, Steven. A Nation under Our Feet: Black Political Struggles in the Rural South from Slavery to the Great Migration. Cambridge, Mass.: Belknap Press, 2003.

History Matters, LLC, "Loudoun County African-American Historic Architectural Resources Survey" (2004) <https://www.loudoun.gov/index.aspx?NID=1868>. Accessed April, 15 2017.

"History of Schools for the Colored Population," Section C of *Special Report of the Commissioner of Education on the Improvement of Public Schools in the District of Columbia, 1871*. Issued by the first Commissioner of Education, Henry Barnard. Arno Press and New York Times (1969).

The American Negro: His History and Literature, Ayer Publishing (1970)  
<http://books.google.com/books?id=7ltzHlxXg5IC&printsec=frontcover&dq=%22leland+war ring%22#PPA185,M1>. Accessed April 16, 2017.

Howard University – Reconstruction Era:  
<http://www.howard.edu/library/reference/guides/reconstructionera/>. Accessed April 16, 2017.

Kalbian, Maral S. and Leila. O. W. Bower, *Destination Middleburg: A Walking Tour Into the Past*, October 2001.

Lee, Deborah A. *Honoring Their Paths: African American Contributions in the Journey Through Hallowed Ground*. Waterford, Va.: The Journey Through Hallowed Ground, 2009.

Library of Virginia. *African American Church Histories in the Library of Virginia*.  
[https://www.lva.virginia.gov/public/guides/African\\_American\\_Churches.pdf](https://www.lva.virginia.gov/public/guides/African_American_Churches.pdf). Accessed April, 17 2017.

Montgomery, William E. "African American Churches in Virginia." Encyclopedia of

Shiloh Baptist Church  
Name of Property

Loudoun County, VA  
County and State

Virginia

[http://www.encyclopediavirginia.org/African\\_American\\_Churches\\_in\\_Virginia\\_1865-1900](http://www.encyclopediavirginia.org/African_American_Churches_in_Virginia_1865-1900).

Accessed April 17, 2017.

Scheel, Eugene M., Loudoun Discovered: Communities, Corners and Crossroads. The Hunt Country and Middleburg, Volume 3. 2001.

Scheel, Eugene M., The History of Middleburg and Vicinity: Honoring the 200<sup>th</sup> Anniversary of the Town, 1987-1987, November, 1987.

Scheel, Eugene, *Civil Rights Movement in Middleburg, Virginia*,  
<http://www.loudounhistory.org/history/civil-rights-middleburg-va.html>. Accessed April 11, 2017.

Scheel, Eugene, "Brown's Corner: a 4-House Huddle," *Loudoun Times Mirror*, 22 July 1978.

Sobel, Mechal. Trabelin' On: The Slave Journey to an Afro-Baptist Faith. Princeton, N.J.: Princeton University Press, 1988.

Thompson, Elaine E. *Courage, My Soul: Historic African American Churches and Mutual Aid Societies*. The Loudoun Museum, 2000.

*In the Watchfires: The Loudoun County Emancipation Association, 1890-1971*, 2005.

"Douglass High School: Legacy of a Changing Era." *Loudoun Magazine*, Leesburg, Virginia, February, 2004.

"A Profound Sense of Spirituality: African American Churches and their Music." *Loudoun Magazine*, Leesburg, Virginia, February, 2003.

United States. Federal Census 1890.

United States. Federal Census 1900.

United States. Federal Census 1910.

Virginia. Loudoun County Deeds.

---

**Previous documentation on file (NPS):**

preliminary determination of individual listing (36 CFR 67) has been requested

previously listed in the National Register

previously determined eligible by the National Register

designated a National Historic Landmark

Shiloh Baptist Church  
Name of Property

Loudoun County, VA  
County and State

\_\_\_\_\_ recorded by Historic American Buildings Survey # \_\_\_\_\_  
\_\_\_\_\_ recorded by Historic American Engineering Record # \_\_\_\_\_  
\_\_\_\_\_ recorded by Historic American Landscape Survey # \_\_\_\_\_

**Primary location of additional data:**

- State Historic Preservation Office
- \_\_\_\_\_ Other State agency
- \_\_\_\_\_ Federal agency
- Local government
- \_\_\_\_\_ University
- \_\_\_\_\_ Other

Name of repository: Department of Historic Resources, Richmond, VA; Loudoun County, VA

**Historic Resources Survey Number (if assigned):** DHR No. 259-0162-0007

---

**10. Geographical Data**

**Acreeage of Property** .11

Use either the UTM system or latitude/longitude coordinates

**Latitude/Longitude Coordinates**

Datum if other than WGS84: \_\_\_\_\_  
(enter coordinates to 6 decimal places)

- 1. Latitude: 38.971610                      Longitude: -77.731680
- 2. Latitude:                                      Longitude:
- 3. Latitude:                                      Longitude:
- 4. Latitude:                                      Longitude:

**Or**

**UTM References**

Datum (indicated on USGS map):

NAD 1927    or     NAD 1983

- 1. Zone:                                      Easting:                                      Northing:
- 2. Zone:                                      Easting:                                      Northing:

Shiloh Baptist Church  
Name of Property

Loudoun County, VA  
County and State

3. Zone: Easting: Northing:

4. Zone: Easting: Northing:

**Verbal Boundary Description** (Describe the boundaries of the property.)

The boundary conforms to the parcel lines defined as tax parcels 87A2-1-16 and 87A2-1-17 as recorded by Loudoun County, Virginia. The true and correct boundaries are shown on the attached Tax Parcel Map and Location Map.

**Boundary Justification** (Explain why the boundaries were selected.)

The boundary includes two parcels, the site of the church and the site of the former parsonage. The historic boundary matches the legal boundary as it has existed since the church and parsonage were constructed, and thus encompasses both the property's historic setting and all known historic resources.

---

**11. Form Prepared By**

name/title: Judith James, Gerri Nelson (Shiloh Baptist Church)  
organization: Shiloh Baptist Church  
street & number: 304 East Marshall Street  
city or town: Middleburg state: VA zip code: 20118  
e-mail: Judith.R.James@gmail.com  
telephone: \_\_\_\_\_  
date: 5/31/17

---

**Additional Documentation**

Submit the following items with the completed form:

- **Maps:** A **USGS map** or equivalent (7.5 or 15 minute series) indicating the property's location.
- **Sketch map** for historic districts and properties having large acreage or numerous resources. Key all photographs to this map.
- **Additional items:** (Check with the SHPO, TPO, or FPO for any additional items.)

**Photographs**

Submit clear and descriptive photographs. The size of each image must be 1600x1200 pixels (minimum), 3000x2000 preferred, at 300 ppi (pixels per inch) or larger. Key all photographs to the sketch map. Each photograph must be numbered and that number must correspond to the photograph number on the photo log. For simplicity, the name of the photographer, photo date, etc. may be listed once on the photograph log and doesn't need to be labeled on every photograph.

Shiloh Baptist Church  
Name of Property

Loudoun County, VA  
County and State

## Photo Log

Name of Property: Shiloh Baptist Church

City or Vicinity: Middleburg

County: Loudoun

State: Virginia

Photographer: Aubrey Von Lindern

Date Photographed: 3/15/2017

Description of Photograph(s) and number, include description of view indicating direction of camera:

1 of 15. Va\_LoudounCounty\_Shiloh\_Baptist\_Church\_0001  
Church, Primary Elevation, Southeast, Oblique

2 of 15. Va\_LoudounCounty\_Shiloh\_Baptist\_Church\_0002  
Church, Primary Elevation

3 of 15. Va\_LoudounCounty\_Shiloh\_Baptist\_Church\_0003  
Church, West Elevation, Main Entrance

4 of 15. Va\_LoudounCounty\_Shiloh\_Baptist\_Church\_0004  
Church, West Elevation

5 of 15. Va\_LoudounCounty\_Shiloh\_Baptist\_Church\_0005  
Church, Primary Elevation, Date Stone

6 of 15. Va\_LoudounCounty\_Shiloh\_Baptist\_Church\_0006  
Church, Primary Elevation, Small Fixed Window

7 of 15. Va\_LoudounCounty\_Shiloh\_Baptist\_Church\_0007  
Church, Interior, Vestibule Stairway

8 of 15. Va\_LoudounCounty\_Shiloh\_Baptist\_Church\_0008  
Church, Interior, Sanctuary Entrance

9 of 15. Va\_LoudounCounty\_Shiloh\_Baptist\_Church\_0009  
Church, Interior, Sanctuary, Looking Southwest

Shiloh Baptist Church  
Name of Property

Loudoun County, VA  
County and State

10 of 15. Va\_LoudounCounty\_Shiloh\_Baptist\_Church\_0010  
Church, Interior, Sanctuary, Looking Southeast

11 of 15. Va\_LoudounCounty\_Shiloh\_Baptist\_Church\_0011  
Church, Interior, Sanctuary, Looking Northeast

12 of 15. Va\_LoudounCounty\_Shiloh\_Baptist\_Church\_0015  
Church, Interior, Sanctuary, Windows

13 of 15. Va\_LoudounCounty\_Shiloh\_Baptist\_Church\_0013  
Church, Sanctuary Entrance, Close Up

14 of 15. Va\_LoudounCounty\_Shiloh\_Baptist\_Church\_0014  
Church, Sanctuary, Looking North

15 of 15. Va\_LoudounCounty\_Shiloh\_Baptist\_Church\_0015  
Church, Lower Level, Fellowship Hall, Looking north.

**Paperwork Reduction Act Statement:** This information is being collected for applications to the National Register of Historic Places to nominate properties for listing or determine eligibility for listing, to list properties, and to amend existing listings. Response to this request is required to obtain a benefit in accordance with the National Historic Preservation Act, as amended (16 U.S.C.460 et seq.).

**Estimated Burden Statement:** Public reporting burden for this form is estimated to average 100 hours per response including time for reviewing instructions, gathering and maintaining data, and completing and reviewing the form. Direct comments regarding this burden estimate or any aspect of this form to the Office of Planning and Performance Management, U.S. Dept. of the Interior, 1849 C. Street, NW, Washington, DC.



Virginia Cultural Resource Information System

**LOCATION MAP**

**Shiloh Baptist Church**

**Middleburg, Loudoun County, VA**

**DHR No. 259-0162-0007**

**Latitude/Longitude Coordinates**

1. Latitude: 38.971610

Longitude: -77.731680



Feet

0 50 100 150 200

1:2,257 / 1"=188 Feet

**Title:**

**Date: 6/22/2017**

*DISCLAIMER: Records of the Virginia Department of Historic Resources (DHR) have been gathered over many years from a variety of sources and the representation depicted is a cumulative view of field observations over time and may not reflect current ground conditions. The map is for general information purposes and is not intended for engineering, legal or other site-specific uses. Map may contain errors and is provided "as-is". More information is available in the DHR Archives located at DHR's Richmond office.*

*Notice if AE sites: Locations of archaeological sites may be sensitive the National Historic Preservation Act (NHPA), and the Archaeological Resources Protection Act (ARPA) and Code of Virginia §2.2-3705.7 (10). Release of precise locations may threaten archaeological sites and historic resources.*



SKETCH MAP  
Shiloh Baptist Church  
Middleburg, Loudoun County, VA  
DHR No. 259-0162-0007



Contributing Resources  
A - Shiloh Baptist Church (Building)  
B - Wrought Iron Fence (Object)  
C - Stone Wall (Structure)



PHOTO KEY  
Shiloh Baptist Church  
Middleburg, Loudoun County, VA  
DHR No. 259-0162-0007

Site of the Old Parsonage (No Longer Extant)

N.  
J  
A  
Y  
S  
T  
R  
E  
E  
T

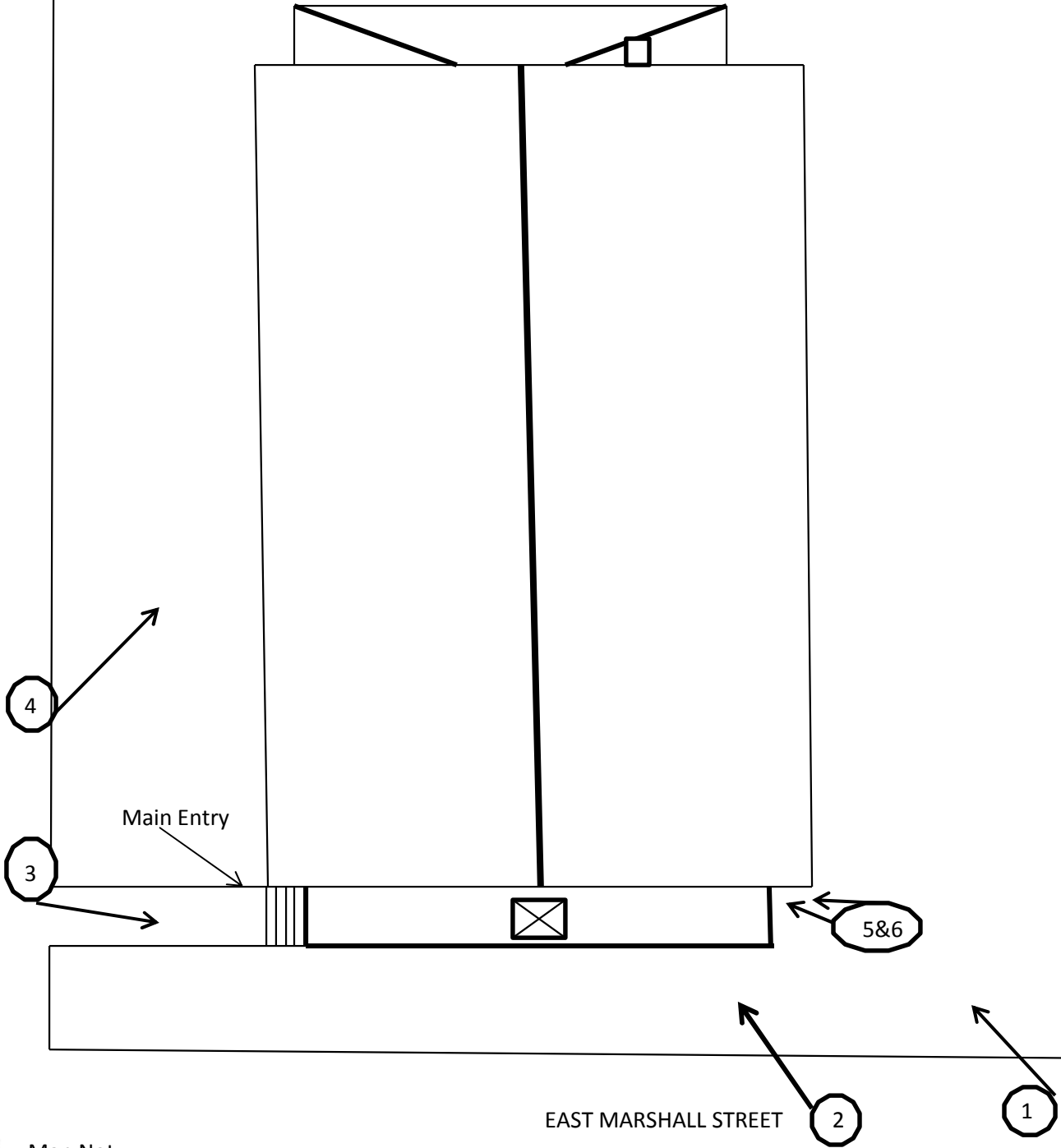

 N  
Map Not  
Drawn To Scale

EAST MARSHALL STREET



Virginia Cultural Resource Information System

**TOPOGRAPHIC MAP**

**Shiloh Baptist Church**

**Middleburg, Loudoun County, VA**

**DHR No. 259-0162-0007**

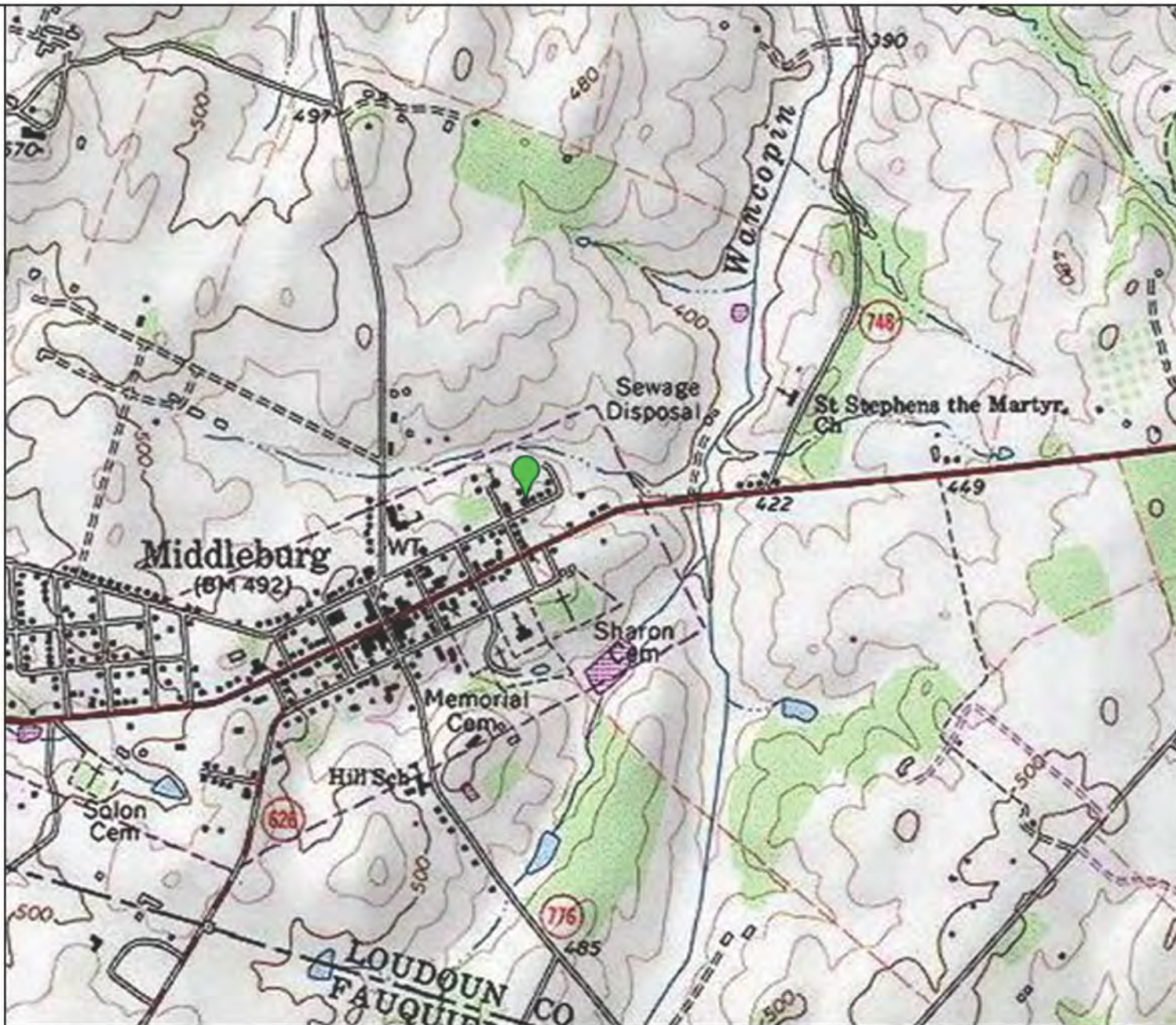

Feet



1:18,056 / 1"=1,505 Feet

**Title:**

**Date: 6/22/2017**

*DISCLAIMER: Records of the Virginia Department of Historic Resources (DHR) have been gathered over many years from a variety of sources and the representation depicted is a cumulative view of field observations over time and may not reflect current ground conditions. The map is for general information purposes and is not intended for engineering, legal or other site-specific uses. Map may contain errors and is provided "as-is". More information is available in the DHR Archives located at DHR's Richmond office.*

*Notice if AE sites: Locations of archaeological sites may be sensitive the National Historic Preservation Act (NHPA), and the Archaeological Resources Protection Act (ARPA) and Code of Virginia §2.2-3705.7 (10). Release of precise locations may threaten archaeological sites and historic resources.*

TAX PARCEL MAP 1 OF 2  
Shiloh Baptist Church  
Middleburg, Loudoun County, VA  
DHR No. 259-0162-0007  
Parcel 304  
Loudoun County GIS, Town of Middleburg

PARID: 538394911000  
SHILOH BAPTIST CHURCH, THE,

304 MARSHALL ST E

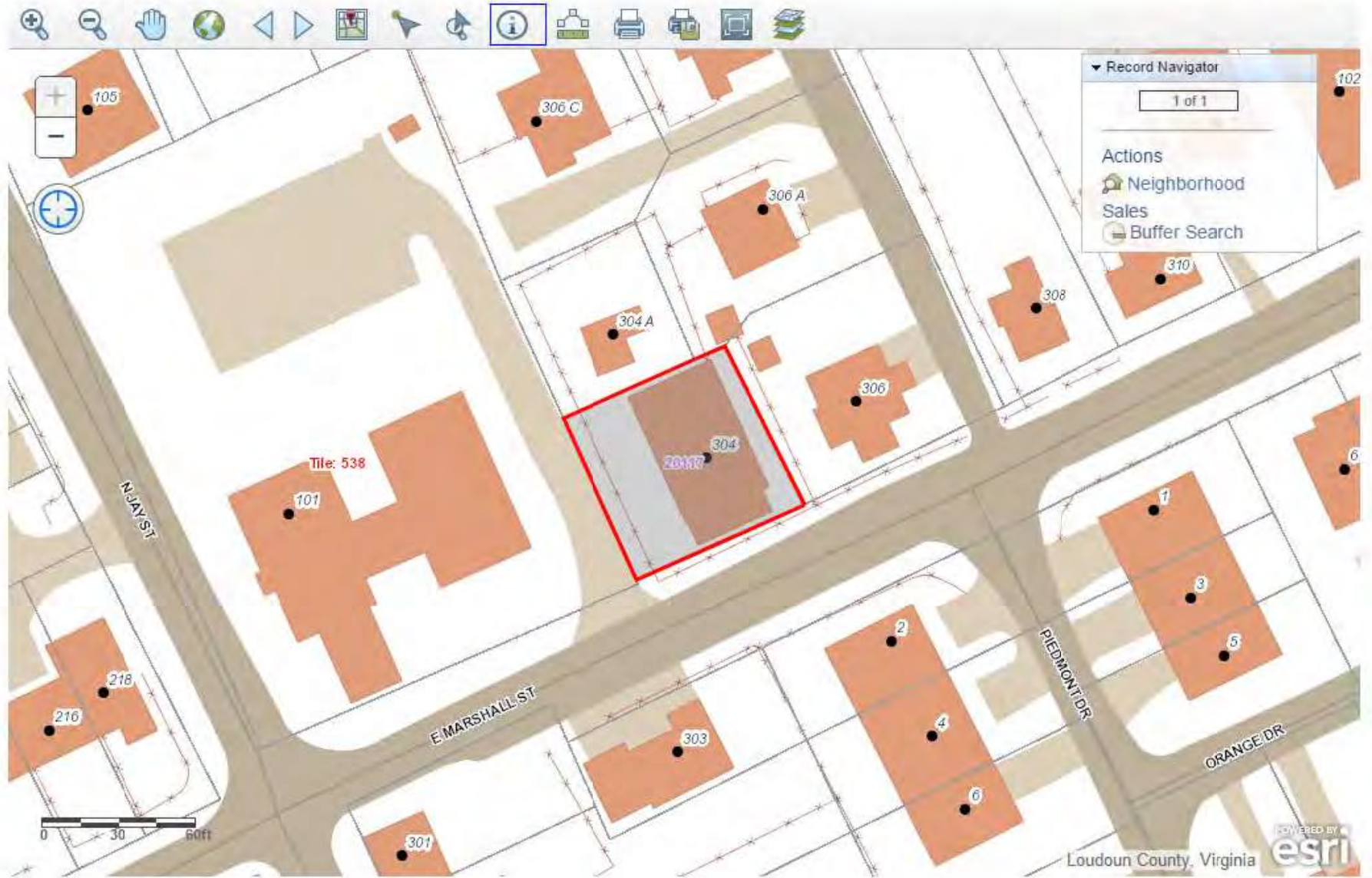

TAX PARCEL MAP 2 OF 2  
Shiloh Baptist Church  
Middleburg, Loudoun County, VA  
Parcel 304A  
Loudoun County GIS, Town of Middleburg

PARID: 538394316000  
SHILOH BAPTIST CHURCH, THE.

304 MARSHALL ST E

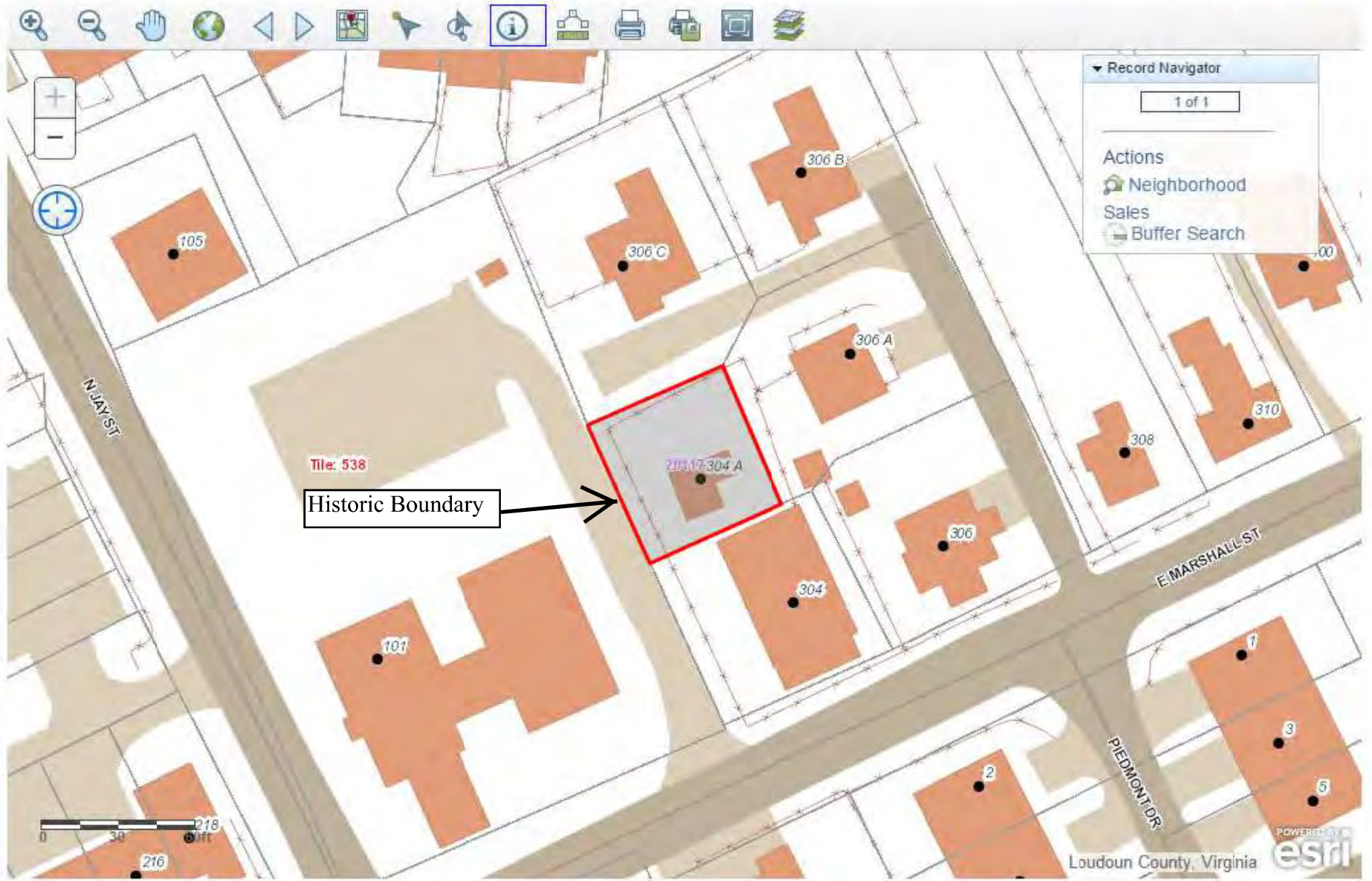





Boileh Baptist  
Church

SERVICE 11:00 AM  
SCHOOL 9:45 AM  
SERVICE Wed. 7:00  
Pastor: Rev. Herman Nelson  
Everyone Welcome







Shiloh Baptist  
Church

Worship Service  
Church School  
Prayer Service  
Pastor: Rev. Howard  
Everyone Welcome



SILVER SPRING  
CHURCH  
REBUILT 28 SEPT.  
1913







So We'll Never Be  
Shut Out of Church

1. The church is a place of worship and prayer. It is a place where we can meet with God and His people. It is a place where we can find comfort and strength in our time of need. It is a place where we can find hope and joy in our lives.

2. The church is a place of fellowship and love. It is a place where we can share our lives with one another and support one another in our journey of faith. It is a place where we can find a sense of community and belonging. It is a place where we can find a home.

3. The church is a place of service and ministry. It is a place where we can use our gifts and talents to serve others and make a difference in the world. It is a place where we can find a sense of purpose and meaning in our lives. It is a place where we can find a way to live out our faith.

4. The church is a place of hope and faith. It is a place where we can find a sense of direction and purpose in our lives. It is a place where we can find a way to overcome our struggles and find a path forward. It is a place where we can find a way to live out our faith and make a difference in the world.











DEO CREXIT  
DAWSON





30th Pastoral Anniversary  
Reverend Herman Nelson  
Arise, Shepherd and Thy Flock Follow Thee, O Lord  
King of My Life. - Psalm 23:1

CHILDREN BAPTIST  
SUNDAY SCHOOL



UNITED STATES DEPARTMENT OF THE INTERIOR  
NATIONAL PARK SERVICE

NATIONAL REGISTER OF HISTORIC PLACES  
EVALUATION/RETURN SHEET

Requested Action: Nomination

Property Name: Shiloh Baptist Church

Multiple Name:

State & County: VIRGINIA, Loudoun

Date Received: 10/10/2017      Date of Pending List: 11/14/2017      Date of 16th Day: 11/29/2017      Date of 45th Day: 11/24/2017      Date of Weekly List:

Reference number: SG100001852

Nominator: State

Reason For Review:

- |   |  |   |
|---|--|---|
| <input type="checkbox"/> Appeal           | <input type="checkbox"/> PDIL            | <input type="checkbox"/> Text/Data Issue    |
| <input type="checkbox"/> SHPO Request     | <input type="checkbox"/> Landscape       | <input type="checkbox"/> Photo              |
| <input type="checkbox"/> Waiver           | <input type="checkbox"/> National        | <input type="checkbox"/> Map/Boundary       |
| <input type="checkbox"/> Resubmission     | <input type="checkbox"/> Mobile Resource | <input type="checkbox"/> Period             |
| <input checked="" type="checkbox"/> Other | <input type="checkbox"/> TCP             | <input type="checkbox"/> Less than 50 years |
|   | <input checked="" type="checkbox"/> CLG  |   |

Accept       Return       Reject      11/24/2017 Date

Abstract/Summary  
Comments:

Recommendation/ Criteria      Accept, National Register Criteria A and C.

Reviewer      Patrick Andrus Patrick Andrus      Discipline      Historian

Telephone      (202)354-2218      Date      11/24/2017

DOCUMENTATION:      see attached comments : No      see attached SLR : No

If a nomination is returned to the nomination authority, the nomination is no longer under consideration by the National Park Service.

**Town of Middleburg**  
**County of Loudoun**

10 West Marshall Street  
Post Office Box 187  
Middleburg, Virginia 20118  
Telephone: 540-687-5152  
Fax: 540-687-3804



**HISTORIC DISTRICT REVIEW COMMITTEE**

*William Turnure, Chair*  
*Punkin Lee, Vice Chair*  
William Anderson  
Virginia Jenkins  
Bridge Littleton  
Margaret Littleton  
Pam Mickley-Albers  
Linda Wright

September 7, 2017

James Hare  
Director, Survey and Register Division  
Department of Historic Resources  
2801 Kensington Avenue  
Richmond, VA 23221

RE: **Shiloh Baptist Church, Town of Middleburg, Loudoun County**

Dear Mr. Hare:

Thank you for your letter of July 18, 2017 wherein you indicate that DHR is planning to present a National Register nomination for Shiloh Baptist Church to Virginia's State Review Board and Historic Resources Board on September 21, 2017 and wherein you invite comments from our Architectural Review Board (the Middleburg Historic District Review Committee, or HDRC) because this resource is within the jurisdiction of our Certified Local Government.

The HDRC met on August 3, 2017 to review the nomination and is pleased to offer its full support. The nomination appears to be very thorough in its discussion of Historic Context beginning on page 11. It is also worth noting that the Middleburg Town Council recently adopted a Resolution in Honor and Appreciation of the 150th anniversary of the founding of the congregation in 1867.

The nomination also appears to be complete and accurate in its physical description of the property and its architecture. In addition to the architectural discussion as contained within the nomination, the HDRC specifically values Shiloh due to its integration into the fabric of the surrounding neighborhood on East Marshall Street - one of our "back streets" paralleling Washington Street/US 50. Middleburg is very fortunate to have Shiloh and a few other select resources along and around our back streets that anchor the streetscapes and help to tie the blocks together as true neighborhoods.

The HDRC has no additional comments or concerns to offer. Thank you for the opportunity to review and comment on the nomination.

Sincerely,

Dorothy "Punkin" Lee  
Vice Chair, Historic District Review Committee

William M. Moore  
CLG Coordinator



# COMMONWEALTH of VIRGINIA

## Department of Historic Resources

2801 Kensington Avenue, Richmond, Virginia 23221

Molly Joseph Ward  
*Secretary of Natural Resources*

Julie V. Langan  
*Director*

Tel: (804) 367-2323  
Fax: (804) 367-2391  
[www.dhr.virginia.gov](http://www.dhr.virginia.gov)

October 5, 2017

Mr. Paul Loether  
Chief, National Register of Historic Places and National Historic Landmarks Programs  
National Park Service 2280  
National Register of Historic Places  
Mail Stop 7228  
1849 C St, NW  
Washington, D.C. 20240

**Re: Shiloh Baptist Church, Loudoun County, Virginia**

Dear Mr. Loether:

The enclosed disk contains the true and correct copy of the nomination for the **Shiloh Baptist Church** to the National Register of Historic Places. Submitted for your review, the nomination has been considered, and approved, by the State Review Board and the Virginia SHPO has recommended it for listing. Any letters of comment or objection have been copied at the end of the nomination material, along with any FPO notification letters.

Should you have any questions, please do not hesitate to contact me. My direct phone line is 804-482-6439.

Sincerely,

Lena Sweeten McDonald  
National/State Register Historian

Enclosures

Western Region Office  
962 Kime Lane  
Salem, VA 24153  
Tel: (540) 387-5443  
Fax: (540) 387-5446

Northern Region Office  
5357 Main Street  
PO Box 519  
Stephens City, VA 22655  
Tel: (540) 868-7029  
Fax: (540) 868-7033

Eastern Region Office  
2801 Kensington Avenue  
Richmond, VA 23221  
Tel: (804) 367-2323  
Fax: (804) 367-2391