

United States Department of the Interior  
National Park Service

SG 3517

# National Register of Historic Places Registration Form

This form is for use in nominating or requesting determinations for individual properties and districts. See instructions in National Register Bulletin, *How to Complete the National Register of Historic Places Registration Form*. If any item does not apply to the property being documented, enter "N/A" for "not applicable." For functions, architectural classification, materials, and areas of significance, enter only categories and subcategories from the instructions.

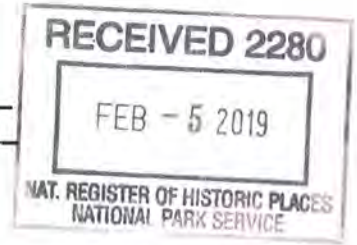

### 1. Name of Property

Historic name: Market Street Bridge (preferred)

Other names/site number: Steubenville Bridge (BR-0067 - WV Site Number)

Name of related multiple property listing:

N/A

(Enter "N/A" if property is not part of a multiple property listing)

### 2. Location

Street & number: WV Route 2 spur, Mile Post 0.01 / Market Street

City or town: Follansbee/Steubenville State: WV/OH County: Brooke/Jefferson

Not for Publication:  Vicinity:

### 3. State/Federal Agency Certification

As the designated authority under the National Historic Preservation Act, as amended,

I hereby certify that this x nomination \_\_\_ request for determination of eligibility meets the documentation standards for registering properties in the National Register of Historic Places and meets the procedural and professional requirements set forth in 36 CFR Part 60.

In my opinion, the property x meets \_\_\_ does not meet the National Register Criteria. I recommend that this property be considered significant at the following level(s) of significance:

\_\_\_ national \_\_\_ statewide x local

Applicable National Register Criteria:

x A \_\_\_ B x C \_\_\_ D

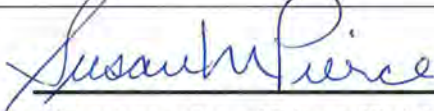
	Deputy State Historic Preservation Officer	<u>1/10/2019</u>
<b>Signature of certifying official/Title:</b>		<b>Date</b>
<u>West Virginia State Historic Preservation Office</u>		
<b>State or Federal agency/bureau or Tribal Government</b>		

In my opinion, the property <u>x</u> meets ___ does not meet the National Register criteria.	
	<u>December 17, 2019</u>
<b>Signature of commenting official:</b>	<b>Date</b>
Deputy State Historic Preservation Officer for Inventory & Registration, State Historic Preservation Office, Ohio History Connection	
<b>Title:</b>	<b>State or Federal agency/bureau or Tribal Government</b>

Market Street Bridge  
Name of Property

Brooke County, WV  
County and State

**4. National Park Service Certification**

I hereby certify that this property is:

- entered in the National Register
- determined eligible for the National Register
- determined not eligible for the National Register
- removed from the National Register
- other (explain:)

*Barbara Bygall*  
Signature of the Keeper

3-21-19  
Date of Action

**5. Classification**

**Ownership of Property**

(Check as many boxes as apply.)

- Private:
- Public – Local
- Public – State
- Public – Federal

**Category of Property**

(Check only **one** box.)

- Building(s)
- District
- Site
- Structure
- Object

Market Street Bridge  
Name of Property

Brooke County, WV  
County and State

**Number of Resources within Property**

(Do not include previously listed resources in the count)

Contributing	Noncontributing	
_____	_____	buildings
_____	_____	sites
<u>1</u>	_____	structures
_____	_____	objects
<u>1</u>	<u>0</u>	Total

Number of contributing resources previously listed in the National Register 0

**6. Function or Use**

**Historic Functions**

(Enter categories from instructions.)

TRANSPORTATION: rail-related

\_\_\_\_\_  
\_\_\_\_\_  
\_\_\_\_\_  
\_\_\_\_\_  
\_\_\_\_\_

**Current Functions**

(Enter categories from instructions.)

TRANSPORTATION: road-related

\_\_\_\_\_  
\_\_\_\_\_  
\_\_\_\_\_  
\_\_\_\_\_  
\_\_\_\_\_

Market Street Bridge  
Name of Property

Brooke County, WV  
County and State

---

## 7. Description

### Architectural Classification

(Enter categories from instructions.)

OTHER: Triple-Span Suspension Bridge

---

---

---

---

---

---

**Materials:** (enter categories from instructions.)

Principal exterior materials of the property:

FOUNDATION: CONCRETE/STONE/STEEL

OTHER (Towers): STEEL

### Narrative Description

(Describe the historic and current physical appearance and condition of the property. Describe contributing and noncontributing resources if applicable. Begin with a **summary paragraph** that briefly describes the general characteristics of the property, such as its location, type, style, method of construction, setting, size, and significant features. Indicate whether the property has historic integrity.)

---

### Summary Paragraph

The Market Street Bridge is a triple-span steel suspension bridge that spans the Ohio River, connecting the city of Steubenville, Ohio with West Virginia, in an area near Follansbee (formerly East Steubenville). Completed in 1905, the bridge was designed by E.K. Morse, constructed by the Ohio Steel Erection Company, and overseen by the Steubenville Bridge Company. The bridge is 1,794 feet long and approximately 22 feet wide. At the time of its construction, the Ohio side of the river had experienced more development than the West Virginia side. The Middle Ferry landing in Ohio was operating adjacent to where the bridge was constructed. On the West Virginia side, the exit off the bridge was less than a mile from the site where a new tin mill was to be built. Today, the setting on both sides of river is moderately developed. Despite alterations, repairs, and maintenance, the bridge possesses a relatively high degree of integrity.

Market Street Bridge  
Name of Property

Brooke County, WV  
County and State

## Narrative Description

The Market Street Bridge is a triple-span steel suspension bridge with an overall length of 1,794 feet and a roadway width of approximately 22 feet.<sup>1</sup> Suspension bridges feature a main cable that has suspender cables holding-up the deck; the main cable is tied into an anchorage. Stiffening helps to keep the bridge from oscillating during high winds or when subjected to heavy loads.<sup>2</sup> The three spans of the Market Street Bridge that cross the Ohio River are cable-suspended with a stiffening through Warren truss.<sup>3</sup> A truss is a structure of connected elements usually forming triangular units.<sup>4</sup> The cables are suspended from two steel towers that rise from cut stone piers. The structure has a 5'-4" sidewalk on the downstream side that is accessed via steel stairs on the Ohio side. Hand-railings are basic fence-like steel elements. Connections are primarily riveted.<sup>5</sup>

The following is a detailed description of the bridge's main structural components.

### *Deck System:*

Originally, the former toll bridge had two lanes of wood decking laid to accommodate streetcars and foot-traffic. The span crossed over the Ohio River; railroad tracks owned by the Pittsburgh, Wheeling and Kentucky Railway Company, that were on both the Ohio and West Virginia sides of the river; High Street, Water Street and Market Street in Steubenville, Ohio along with Alley A; and the Steubenville Public Wharf.<sup>6</sup> The width of the roadway was a constant 20.7'<sup>7</sup> Curbs were spaced 19'4" apart and timbers surrounded the streetcar tracks.<sup>8</sup> But because fires were so common, asphalt pavement was applied over the wood.<sup>9</sup> The unlit pedestrian walkway on the downstream side, outside of the trusses, was also wooden.<sup>10</sup> There was no load limit nor method used for monitoring the weight of loads crossing the bridge.

---

<sup>1</sup> Courtney Fint (WVDOT), "West Virginia Historic Property Inventory Form," 5 May 2009, p 3, email to kkidder from spierce, 24 Aug. 2017.

<sup>2</sup> Nathan Holth, "An Introduction to Historic Bridges," *Historic Bridges*, 2010, [historicbridges.org/index.htm](http://historicbridges.org/index.htm), PPT slide 183, accessed 03 Apr. 2018.

<sup>3</sup> The Warren Truss uses equilateral triangles to spread out the loads on the bridge. This is opposed to the Neville Truss which used isosceles triangles. The equilateral triangles minimize the forces to only compression and tension. Interestingly, as a load (such as a car or train) moves across the bridge sometimes the forces for a member switch from compression to tension. This happens especially to the members near the center of the bridge. (Garrett's Bridges, By Garrett Boon on January 4, 2011 -- Modified on November 28, 2016 [garrettsbridges.com/design/warren-truss/](http://garrettsbridges.com/design/warren-truss/))

<sup>4</sup> Wikipedia, "Truss bridge," 7 Apr. 2018, [en.wikipedia.org/wiki/Truss\\_bridge](https://en.wikipedia.org/wiki/Truss_bridge), accessed 14 Apr. 2018.

<sup>5</sup> Fint, p 4.

<sup>6</sup> Brooke County West Virginia, Samuel Biern of Huntington, WV and the State of West Virginia, 29 December 1941; Office of the Clerk of the County Court, City of Wellsburg, p 514.

<sup>7</sup> Wikipedia, "Market Street Bridge (Ohio River)," accessed 18 May 2017, [https://en.wikipedia.org/wiki/Market\\_Street\\_Bridge\\_\(Ohio\\_River\)](https://en.wikipedia.org/wiki/Market_Street_Bridge_(Ohio_River)), p.1.

<sup>8</sup> West Virginia Department of Transportation, "Market Street Bridge Inventory Report," 2012, p 1, email to kkidder from spierce, 24 Aug. 2017.

<sup>9</sup> "Market Street Bridge (Ohio River)," p 1.

<sup>10</sup> "Market Street Bridge Inventory Report," p 3.



Market Street Bridge

Name of Property

Brooke County, WV

County and State

The present-day two-lane deck of the Market Street Bridge is a 5" open steel grid (installed in 1941) that is 21'-8" wide at the truss section and 22'-8" wide on the suspension span. Both the deck width and horizontal clearance vary; the girder approach span has the least width distance of 20'-7". There is no curb on either side. The box-like steel truss that surrounds the deck is a quadrangular Warren with verticals.<sup>11</sup> The bridge floor is approximately 75 feet above the Ohio River.<sup>12</sup> The bridge crosses over Market Street, four lanes of Ohio Route 7,<sup>13</sup> and railroad tracks that are now owned by Norfolk Southern Railways and are on both sides of the river.<sup>14</sup>

The metal grid deck is considered ideal for bridge rehabilitation projects where weight reduction, among other considerations, are paramount to the structure's rehabilitation. First used during the 1930's, the metal grid deck has both primary and secondary that interconnect and form either a rectangular or a diagonal pattern. They can be filled with reinforced concrete or left open as is the case with the Market Street Bridge.<sup>15</sup>

New to the bridge in 2011 are a weigh-in-motion device to detect overweight vehicles and roller scaffolding.<sup>16</sup> The roller scaffolding supports workmen while they are working on the top and sides of a bridge without the use of ladders and/or staging; inspectors use it, also.<sup>17</sup> According to Adrien Glassner, a bridge engineer with the West Virginia Transportation Department, the roller scaffolding does not permanently change the deck. While it is present, the scaffolding can be seen from underneath the bridge; when it is removed, there is no telltale sign of its past presence. The roller scaffolding that is present on the Market Street Bridge was placed there by the company awarded the ten-year contract to inspect the bridge. It is much more economic to leave the scaffolding in place then to set it up every time it is needed.<sup>18</sup> Also in 2011, a new rocker post with maintenance free pins that allow for the elimination of grease fittings was installed. The rocker post accommodates the thermal movement of the 700-foot span;<sup>19</sup> thermal movement is the expansion and contraction of materials in response to temperature changes.<sup>20</sup>

There is a 5'4" wide cantilevered steel plated sidewalk (installed in 1941) that is accessed via steel stairs on the western downstream side. The width of the sidewalk decreases at the Ohio

---

<sup>11</sup> "Market Street Bridge Inventory Report," p 1.

<sup>12</sup> Mike and Judy Lohr, "A Short History of the Steubenville (Market Street) Bridge," Nov 2010, p 2.

<sup>13</sup> Matthew Lewellyn, et al (Burgess and Niple), "Revitalization of an Ohio River Suspension Bridge," Dec 2012, p 9.

<sup>14</sup> "Market Street Bridge Inventory Report," p 2.

<sup>15</sup> Brandon Chavel, Ph.D., PE. "Steel Bridge Design Handbook. Bridge Deck Design," U.S. Department of Transportation. Federal Highway Administration. Publication No. FHWA-IF-12-052-Vol.17, 2012, <https://www.fhwa.dot.gov/bridge/steel/pubs/if12052/volume17.pdf>. Accessed 5 Nov. 2018.

<sup>16</sup> Lewellyn, p 5.

<sup>17</sup> Lewellyn, p 10.

<sup>18</sup> Telephone interview with Adrien Glasser (West Virginia Department of Highways) by Dr. Kathy Kidder-Wilkerson, 25 Jul. 2018.

<sup>19</sup> Lewellyn, p 14.

<sup>20</sup> *Socratic*, "How does thermal expansion affect bridges?" 7 Oct. 2015 <https://socratic.org/physics/heat/thermalexpansion>, accessed 25 Jul. 2018.

Market Street Bridge

Brooke County, WV

Name of Property

County and State

splay saddle; the splay saddle allows wires or strands to spread out for connection to the bridge anchorage. To provide traction on the walkway, an epoxy grit surface was added in 2011. The walkway's hand-railings are basic fence-like steel rails that are seven-inches wide. There are three rails between any two posts; the top rail is 36" high. Between the first and second rails there is a gap of eight-inches; between the second and third rails is a gap of seven-inches (Photo # 6). Two-hundred-twelve lights, added in 2011, provide continuous lighting along the pedestrian walkway (Photo # 8). The fence, running along the downstream trusses on the downstream side was added in 2011 and is positioned between the traffic and pedestrians.<sup>21</sup>

### *Suspension System:*

Originally, and currently, the main span of the three-cable suspension crossing over the Ohio River is 700 feet long; the two remaining spans are 260 feet long each. The west approach consists of two deck girder spans and five spans of the original riveted steel through truss, known as a quadrangular Warren with verticals. Each main suspension cable consists of 1,498 parallel, No. 8 Birmingham wires, and each wire measures 0.165" in diameter. The cables are suspended from two steel towers that rise 210 feet from cut stone piers. The wires are coated with red lead and wrapped perpendicularly with No. 9 soft double galvanized wire.<sup>22</sup> Originally, all stiffening truss connections were made using intermediate welding and all suspender connections were riveted.

The current suspension system has a new suspender connection that is needed for thermal movement which is the expansion or contraction of the bridge due to changes in temperature. Also, four of the eight original rocker posts, the stiffening truss connections to the towers, were replaced in 2011.<sup>23</sup> A rocker post is fastened to the end of a truss or column and permits the movement or slight rotation of the bridge.<sup>24</sup> The stiffening truss connections were made using continuous welding instead of intermediate.<sup>25</sup> A catcher beam back-up system for the cable suspenders was installed at multiple panels in 2011.<sup>26</sup> There are ten cable suspender retrofits (an added component not present at the time of original construction)<sup>27</sup> present. A catcher beam is a retrofit that adds redundancy to the pin and hanger system. A catcher beam is a short steel beam attached to the bottom of the cantilevered girder that extends out beneath the suspended girder to "catch" the suspended girder should the pin and hanger assembly fail. The presence of the

---

<sup>21</sup> Lewellyn, p 16.

<sup>22</sup> Ibid, p 11.

<sup>23</sup> "Market Street Bridge Inventory Report," p 4.

<sup>24</sup> Lichtenberger Engineering Library (University of Iowa), "Glossary of Bridge Terminology," [sdrc.lib.uiowa.edu/eng/bridges/WaddellGlossary/GlossR.htm](http://sdrc.lib.uiowa.edu/eng/bridges/WaddellGlossary/GlossR.htm), accessed 18 Apr. 2018.

<sup>25</sup> "Market Street Bridge," Bridges and Tunnels, <http://bridgestunnels.com/bridges/ohio-river/market-street-bridge/>, accessed 26 Apr. 2018.

<sup>26</sup> "Market Street Bridge Inventory Report," p 4.

<sup>27</sup> Merriman and Webster Dictionary, "Retrofit," 28 May 2018, [merriam-webster.com/dictionary/retrofit](http://merriam-webster.com/dictionary/retrofit), accessed 01 Jun. 2018.

Market Street Bridge

Brooke County, WV

Name of Property

County and State

catcher beam helps to maintain the integrity and safety of the bridge.<sup>28</sup> At each retrofit, bolts have replaced the original rivets.<sup>29</sup> Also, in 2011, catenary lighting to outline the cables with 160 white necklace luminaries was added.<sup>30</sup>

### *Towers*

The two steel towers of the Market Street Bridge control the load rating of the bridge and serve as anchors.<sup>31</sup> The height of the towers is approximately 210 feet.<sup>32</sup> Originally, the two steel towers were unpainted and not illuminated. In addition, the towers had decorative cresting and finials, and were open, i.e., not covered with steel plates (see Figure 1 below).



*Figure 1: Early depiction of Market Street Bridge illustrating tower finials and cresting. Note the lack of steel plates on the tower. (Courtesy of the Jefferson County Historical Society).*

The current weight load is twelve tons. In 2011, the towers were painted West Virginia University Mountaineer blue and illuminated by 60 directional floodlights.<sup>33</sup> In addition, changes have been made to the towers to provide strengthening and reinforcement. The changes to the towers include the following with the year the change was made in parentheses: repairing the tower stiffening plates by adding welds (2011); installing backup threaded rods and cables to supplement the tower sway bracing eye-bars (2011); adding additional plates to the base of the tower columns to maintain their capacity (2011);<sup>34</sup> adding full-height gusset plates by stitch welding them on to the transverse faces of the towers (2009);<sup>35</sup> adding new top struts between the tower legs (1941); adding reinforcing plates that are the full height of the tower legs (1941); adding diagonal bracing and side reinforcing plates to the deep portal strut

---

<sup>28</sup> Daniel Linzell and Chandana C. Balakrishna, “Steel Pin and Hanger Assembly Replacement Options,” Nebraska Transportation Center, p 10, Jan. 2017, [atc.unl.edu/assets/documents/matcfinal/Linzell\\_SteelPinandHangerAssemblyReplacementOptions.pdf](http://atc.unl.edu/assets/documents/matcfinal/Linzell_SteelPinandHangerAssemblyReplacementOptions.pdf).

<sup>29</sup> Lewellyn, p 16.

<sup>30</sup> Ibid, p 17.

<sup>31</sup> Ibid, p 10.

<sup>32</sup> Fint, p 3.

<sup>33</sup> Lewellyn, p 17.

<sup>34</sup> Ibid, p 16.

<sup>35</sup> Ibid, p 10.



Market Street Bridge

Brooke County, WV

Name of Property

County and State

directly above the roadway (1941);<sup>36</sup> and, adding over 30,000 pounds of new structural steel to the towers (2009).<sup>37</sup> The tower columns are now filled with concrete and new lattice bars have been welded to the columns adjacent to the original lattice work (completed in 1941). Two-inch thick gusset plates are present at the top of the columns to anchor cable strands (also completed in 1941).<sup>38</sup>

*Substructures:*

The substructures of the Market Street Bridge include cut stone piers, concrete stub abutments, and both concrete and steel bents.<sup>39</sup> Abutments support the ends of a bridge and transfer the vertical and horizontal loads from the superstructure to the foundation. The abutments also support the bearing devices and the back-walls and prevent differential settlement and excessive lateral movements.<sup>40</sup> Bents support the vertical load and are placed transverse to the length of a structure. They commonly support beams and girders.<sup>41</sup> Piers support the ends of spans between abutments;<sup>42</sup> they also support the vertical load of a bridge distributing the downward pressure of the overlying structure.<sup>43</sup> In 1905 there were two more piers than currently exist; thus, the piers and bents were numbered differently at that time.<sup>44</sup>

Currently, abutment No. 1 is a reinforced concrete stub abutment. Bent No. 1 consists of two concrete pedestals. Bent No. 2 is an open steel pier with concrete pedestals. Bent No. 3 has steel columns embedded in a concrete divider on Ohio Route 7. Bent No. 4 has a steel pier cap and bracing and steel columns with concrete foundations. Anchor No. 1 is a reinforced concrete encased tower with cable anchorages attached to eye-bars leading into the base. Bent No. 5 is a steel rocker bent. Abutment No. 2 is a reinforced concrete stub abutment and it also acts as the anchorage for the suspension cables.<sup>45</sup> On March 3, 1904, the pier nose of Tower 2 was repaired

---

<sup>36</sup> "Market Street Bridge Inventory Report," p 3.

<sup>37</sup> "Market Street Bridge."

<sup>38</sup> "Market Street Bridge Inventory Report," p 3.

<sup>39</sup> *Ibid*, p 1.

<sup>40</sup> *WisDOT*, "Abutments," *WisDOT Bridge Manual*, Jan. 2018, p 12-3, [wisconsin.dot.gov/dtsdManuals/strct/manuals/bridge/ch12.pdf](http://wisconsin.dot.gov/dtsdManuals/strct/manuals/bridge/ch12.pdf), accessed 07 Jan. 2018.

<sup>41</sup> *Missouri Department of Transportation*, "Safe and Sound Bridge Terminology," [modot.org/northeast/documents/10-12-22SASbridgeterminology.pdf](http://modot.org/northeast/documents/10-12-22SASbridgeterminology.pdf), accessed 20 Sep. 2018.

<sup>42</sup> "Pier (architecture)," *Wikipedia, the Free Encyclopedia*, 13 Mar. 2018, [en.wikipedia.org/w/index.php?title=Pier\\_\(architecture\)&oldid=830173946](http://en.wikipedia.org/w/index.php?title=Pier_(architecture)&oldid=830173946), accessed 26 Apr. 2018.

<sup>43</sup> *Encyclopædia Britannica*, "Pier," 13 Dec 2010, [britannica.com/technology/pier-architecture](http://britannica.com/technology/pier-architecture), accessed 26 Apr. 2018.

<sup>44</sup> "Market Street Bridge Inventory Report," p 4.

<sup>45</sup> *Ibid*, p 1.

Market Street Bridge

Brooke County, WV

Name of Property

County and State

after being damaged by a barge.<sup>46</sup> Two piers, Nos. 2 and 4, were removed during the 1981 rehabilitation.<sup>47</sup>

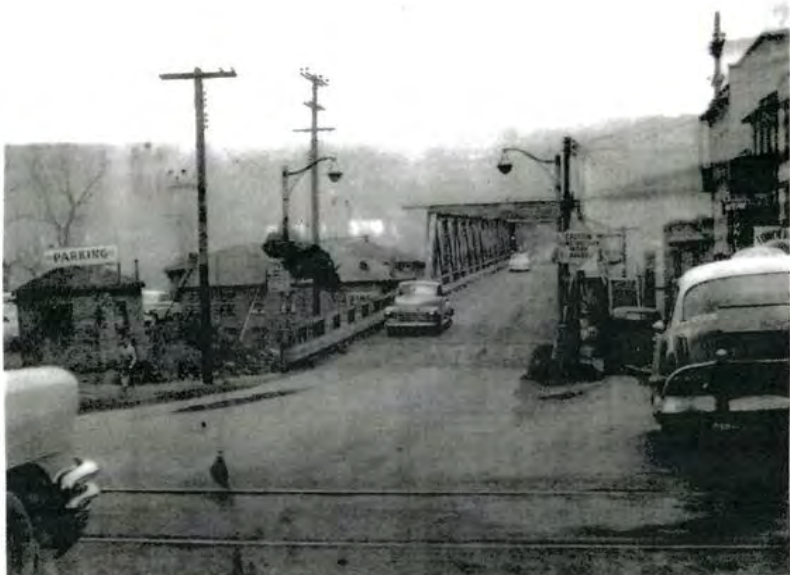

Figure 2: The Market Street Bridge on the Western side (Market Street, Steubenville, Ohio). Note the ornamental street lights. (Courtesy Public Library of Steubenville and Jefferson County)

### *Historic Integrity*

The following is a discussion about the structure's historic integrity:

**LOCATION** is the place where the historic property was constructed or the place where the historic event occurred.<sup>48</sup> The location of the Market Street Bridge has not changed since its original construction. It spans the Ohio River and connects Market Street in Steubenville, Ohio to West Virginia Route 2, including East Steubenville and Follansbee, slightly south. East Steubenville was an unincorporated area across the Ohio River from Steubenville, Ohio. It was already an established and important spot for transportation.<sup>49</sup>

---

<sup>46</sup> On March 3, 1904 at 2 a.m., the steamboat *Virginia* struck the submerged pier of the new bridge. The boat was backing out into the river from the wharf when the starboard side struck the pier, leaving a ten-foot hole in the hull. The boat began to sink in deep water. Owing to the boat's short distance from the shore, the *Virginia* was brought in. About 60 passengers who were on board scrambled on the shoreline and were later picked up by the steamboat *Kanawha*. [bridgestunnels.com/bridges/ohio-river/market-street-bridge/](http://bridgestunnels.com/bridges/ohio-river/market-street-bridge/) accessed 26 Apr. 2018.

<sup>47</sup> "Market Street Bridge Inventory Report," p 4.

<sup>48</sup> "How to Apply the National Register for Evaluation," [nps.gov/nr/publications/bulletins/nrb15\\_8.htm](http://nps.gov/nr/publications/bulletins/nrb15_8.htm), assessed 28 Mar. 2018, p 50.

<sup>49</sup> \_\_\_\_\_. "1904 - East Steubenville," *Follansbee, WV – An Interactive Web History*, 1 Nov. 2012, [follansbeetimeline.com](http://follansbeetimeline.com), accessed 24 Feb. 2018.

Market Street Bridge

Brooke County, WV

Name of Property

County and State

A portion of the land in East Steubenville that bordered both the river and either side of West Virginia Route 2 was used for the eastern exit from the Market Street Bridge. The property was owned by Dohrman Sinclair, the banker and business man behind the impetus for the construction of the bridge.<sup>50</sup> The site was less than one mile from the land to be purchased by the Follansbee brothers for a steel mill.<sup>51</sup> On the Ohio side, the bridge was built at the foot of Market Street where the Middle Ferry Station already existed (see Figure 3). This property was owned by Basil Wells and was a portion of the 1,100 acres along the west side of the Ohio that he received for surveying the area.<sup>52</sup>

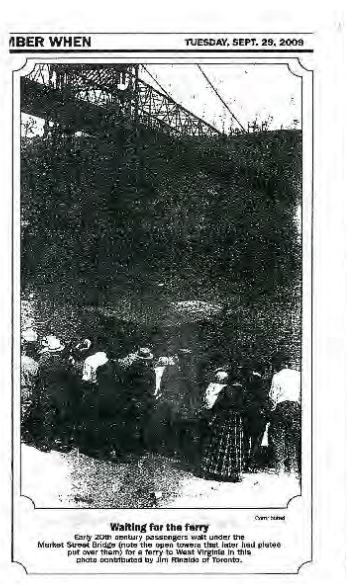

Figure 3: Passengers await the Middle Ferry located under the Market Street Bridge, ca. 1904. (Courtesy Public Library of Steubenville and Jefferson County)

In the early 1900's the bridge was vital for providing laborers a means of crossing the river for work, mostly in local steel mills. Today, over 100 years later, the mills are still providing work for local laborers (albeit on a smaller scale) and the bridge is still just as vital. Therefore, the location of the bridge, and its proximity to the mills on both sides of the river, is still paramount to the economics of surrounding communities. The Market Street Bridge retains a high degree of integrity of location.

**DESIGN** is the combination of elements that create the form, plan, space, structure, and style of a property.<sup>53</sup> Edwin Kirtland (E.K.) Morse (see Figure 4), a consulting engineer living and working in Pittsburgh, Pennsylvania at the time, designed the Market Street Bridge. This triple-span suspension structure is one of the few examples of a bridge with a Warren truss remaining

<sup>50</sup> Wilma Baker, *Father and His Town*, 1961, Three Rivers Press, p 102.

<sup>51</sup> "Market Street Bridge (Ohio River)."

<sup>52</sup> Nancy Recchie and Jeffrey Darbee, "Steubenville Historic Contexts and Resource Evaluation," *Steubenville Historic Landmarks Commission*, Aug. 1993, p 11, [cityofsteubenville.us/wp-content/uploads/2013/07/Steubenville-Historic-Contexts-Resource-Evaluation.pdf](http://cityofsteubenville.us/wp-content/uploads/2013/07/Steubenville-Historic-Contexts-Resource-Evaluation.pdf), accessed 15 Apr. 18.

<sup>53</sup> "How to Apply the National Register Criteria for Evaluation," p 50.

Market Street Bridge

Brooke County, WV

Name of Property

County and State

in the United States; truss bridges are being demolished and replaced with new structures.<sup>54</sup> The bridge's design was reflective of its function in 1905, i.e., providing a transportation route for trolley cars, pedestrians, and limited automobiles between two states. Two major aesthetic changes from the original bridge design occurred during the period of significance: the original wooden deck was replaced with a steel grid deck, and the ornamental finials on the bridge towers, along with the portal cresting (see Figure 5) were removed. From its original design the bridge was multi-modal, carrying pedestrians, trolleys (see Figure 6) and automobiles.<sup>55</sup> Although the trolley rails have been removed, the bridge still carries pedestrian and vehicular traffic. Despite the alterations, the Market Street Bridge retains a high degree of integrity of design.



**Edwin Kirtland Morse**

Brother of Henry G. Morse and Engineer  
For Morse Bridge Company

Source: *Universities and Their Sons*,  
Vol 5, 1900. Digitized By Google

Figure 4: E.K. Morse, designer of the Market Street Bridge

<sup>54</sup> Wikipedia, "Truss bridge." 7 Apr. 2010. [en.wikipedia.org/wiki/Truss\\_bridge](https://en.wikipedia.org/wiki/Truss_bridge), accessed 7 Apr. 2018.

<sup>55</sup> Michael Florio, "Mill Towns Steubenville, Ohio," *Michael Florio Photography*, 03 Feb. 2014, [michaelfroio.com/blog/2014/02/03/mill-towns-steubenville-ohio](http://michaelfroio.com/blog/2014/02/03/mill-towns-steubenville-ohio), accessed 15 May 2018.

Market Street Bridge

Name of Property

Brooke County, WV

County and State

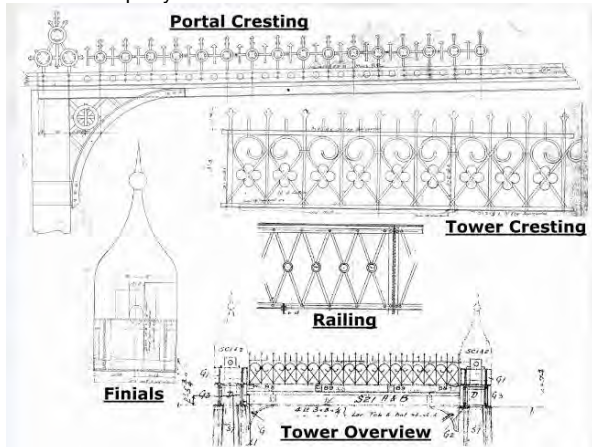

Figure 5: A Sketch of the original cresting on the Market Street Bridge



Figure 6: A postcard showing a trolley crossing the Market Street Bridge

**MATERIALS** are the physical elements that were combined or deposited during a particular period of time and in a particular pattern or configuration to form a historic property.<sup>56</sup> During the 1880's and 1890's, steel began replacing wrought iron as the preferred material for bridge construction (wrought iron had replaced the use of wood for bridge construction in the 1870s). The increasing development of iron and steel manufacturing technology in the early 1900s enabled these theories to be put into practical use. Also, the technology to economically produce metal cables and members promoted the use of the suspension bridge as a way to span great lengths using less material.<sup>57</sup> The original steel for the bridge was fabricated by Jones and Laughlin Steel Company,<sup>58</sup> located just south of Pittsburgh, and Bethlehem Steel<sup>59</sup> of Bethlehem, Pennsylvania. The steel girders and framework were created by the Penn Bridge Company<sup>60</sup> of Beaver County, Pennsylvania. Although this bridge has undergone several repairs and strengthening projects, the majority of the original materials remain in place and are identifiable (e.g., piers, Bethlehem Steel [see Figure 7].) Thus, the bridge has a relatively high degree of integrity of materials.

<sup>56</sup> "How to Apply the National Register Criteria for Evaluation," p 50.

<sup>57</sup> Fint, p 3.

<sup>58</sup> Jones and Laughlin Steel began as the American Iron Company in 1852 but switched to producing steel in 1886. Bethlehem Steel began as Bethlehem Iron in 1852 (ceased iron operations in 1901.)

<sup>59</sup> The Bethlehem Steel Company began in 1899 as a steel producing company; in 1904 they became the primary subsidiary of Bethlehem Steel Corporation. "Bethlehem Steel." *Wikipedia, The Free Encyclopedia*. 17 Apr. 2018, accessed 1 Jun. 2018.

<sup>60</sup> The Penn Bridge Company, established by T.B. White of Beaver Falls, Pennsylvania originally constructed wooden bridges beginning in 1868 under the company name of T.B. White and Sons. They began building iron bridges in 1878 and steel bridges in 1886. They remained in business until 1936. Snedden, Jeff, "Penn Bridge Co. and others put Beaver Falls on the map," *The Times*, 15 Aug. 2017.



Market Street Bridge

Name of Property

Brooke County, WV

County and State



*Figure 7: Original steel purchased from Bethlehem Steel Corporation for the Market Street Bridge is stamped with the foundry's name.*



*Figure 8: In October 1903, stone masons began working on the cut stone piers. (Courtesy of Jefferson County Historical Society)*

Despite alterations completed during the course of strengthening and rehabilitating the bridge and the recent changes to the bridge's aesthetics (paint and lighting), the Market Street Bridge still conveys Morse's original design and possesses a relatively high degree of integrity of location, materials, and design.

Market Street Bridge  
Name of Property

Brooke County, WV  
County and State

### 8. Statement of Significance

#### Applicable National Register Criteria

(Mark "x" in one or more boxes for the criteria qualifying the property for National Register listing.)

- A. Property is associated with events that have made a significant contribution to the broad patterns of our history.
- B. Property is associated with the lives of persons significant in our past.
- C. Property embodies the distinctive characteristics of a type, period, or method of construction or represents the work of a master, or possesses high artistic values, or represents a significant and distinguishable entity whose components lack individual distinction.
- D. Property has yielded, or is likely to yield, information important in prehistory or history.

#### Criteria Considerations

(Mark "x" in all the boxes that apply.)

- A. Owned by a religious institution or used for religious purposes
- B. Removed from its original location
- C. A birthplace or grave
- D. A cemetery
- E. A reconstructed building, object, or structure
- F. A commemorative property
- G. Less than 50 years old or achieving significance within the past 50 years

Market Street Bridge  
Name of Property

Brooke County, WV  
County and State

**Areas of Significance**

(Enter categories from instructions.)

TRANSPORTATION

ENGINEERING

\_\_\_\_\_  
\_\_\_\_\_  
\_\_\_\_\_  
\_\_\_\_\_

**Period of Significance**

1905-1968

\_\_\_\_\_  
\_\_\_\_\_

**Significant Dates**

1905

1922

1941

1953

**Significant Person**

(Complete only if Criterion B is marked above.)

N/A

\_\_\_\_\_  
\_\_\_\_\_

**Cultural Affiliation**

N/A

\_\_\_\_\_  
\_\_\_\_\_

**Architect/Builder**

Morse, Edwin K.

Steinman, David B.

\_\_\_\_\_

Market Street Bridge  
Name of Property

Brooke County, WV  
County and State

**Statement of Significance Summary Paragraph** (Provide a summary paragraph that includes level of significance, applicable criteria, justification for the period of significance, and any applicable criteria considerations.)

The Market Street Bridge is a locally significant structure eligible for listing in the National Register of Historic Places under *Criterion A: Transportation* as a vital transportation link between Ohio and West Virginia and under *Criterion C: Engineering* for its association with civil engineer E.K. Morse (creator of the original design) and bridge designer and renowned engineer Dr. David B. Steinman (rehabilitation designs), as well as for its engineering design. The Period of Significance is 1905 - 1968, beginning with the year that the bridge was placed in service and ending with the 50-year cutoff for eligibility as the bridge remains in service.

---

**Narrative Statement of Significance** (Provide at least **one** paragraph for each area of significance.)

***Criterion A: Transportation***

*Industrial History of Steubenville, Ohio*

Steubenville owes its development as a transportation hub and industrial city to its location along a major navigable river, the Ohio, and to its abundance of natural resources (e.g., coal, natural gas, limestone, clay.)<sup>61</sup> Transportation and industrial growth had a symbiotic relationship, i.e., the two were interdependent and mutually beneficial. During the first half of the nineteenth century, Steubenville was primarily a port town. Between Holliday's Cove, WV (north of Steubenville on the West Virginia side) and in the vicinity of present-day Follansbee, there were three river ferries that transported goods and passengers to the Steubenville marketplaces. There were no bridges crossing the river for wagons or foot traffic. The Upper Ferry crossed the Ohio River near the Old Panhandle Bridge at Holliday's Cove. The Middle Ferry crossed the river near where the Market Street bridge is today. The Lower Ferry was situated just north of present-day Follansbee.<sup>62</sup>

Two ferry-boats provided transportation for horse drawn wagons carrying farmers' goods to the markets and docks at Steubenville and Mingo (Ohio). However, most simply used small boats or walked across the river during low water months. The Ohio River was shallower and narrower in 1900 before major dams were constructed. Mingo Island could be seen near the Follansbee shore in the south part of town. Here the navigation channel twisted to avoid rock ledges and

---

<sup>61</sup> Recchie and Darbee, "Downtown Steubenville History/Architectural Survey Report," 15 Jan. 1986, p 5.

<sup>62</sup> \_\_\_\_\_. "1878 – Passengers Describe Train Trip to Mahan's Farm," *Follansbee, WV – An Interactive Web History*, follansbeetimeline.com, 19 Nov. 2012.

Market Street Bridge

Brooke County, WV

Name of Property

County and State

subsurface sand bars; this stretch of river was long a hazard to steamboats. This is where the *Scioto* rammed the *John Lomas* head-on in 1882.<sup>63</sup>

Keelboats appeared on the Ohio River in the 1790s and the first steamboat pulled into Steubenville in 1811. By 1815, there was an active steamboat building industry in the city; the first woolen mill in the United States was built in Steubenville that same year. Additional industries in Steubenville's early history included coal mining, paper mills, glass factories, potteries, and nail factories. At about the same time, public highways were being built.<sup>64</sup>

Steubenville served as a point where a link was made between river and overland transportation routes. Stagecoach lines connected Steubenville to Pittsburgh, Pennsylvania; Wheeling, West Virginia; and, Canton and Ashtabula, Ohio in the 1820s. Riverboats began appearing at the same time. By 1830 there were taverns; hotels; dry goods stores; tanneries; woolen, grist and flour mills; and at least two banks. The population increased from 2,000 in 1820 to over 6,000 in 1850. In 1856, Frazier, Kilgore and Company erected a rolling mill (the forerunner of steel mills).<sup>65</sup>

The most significant industrial development in the early 1900s was the purchase of the Jefferson Iron Works by Labelle Iron in 1900. A 25-acre tract was purchased at the same time and a new facility was built at the south end of town. It would become one of the largest iron and steel plants in the United States.<sup>66</sup> As the industry in the city prospered Steubenville's population continued to increase.

Like the rest of the country, Steubenville struggled during the great depression of 1893. Many buildings in the city were vacant and advertised for rent. At age 33, Dohrman Sinclair was intent on a solution to the problem of unemployment. There had been a recent fire in downtown Steubenville that claimed, "one of the newest and finest"<sup>67</sup> buildings in town; one that housed apartments, a catering service and a ballroom. Burned completely to the ground, it was an \$85,000 loss. Many citizens brought forth complaints about the inadequate fire protection that existed in Steubenville. Mr. Sinclair had a vision to build a city Water Works, putting men to work and providing long-lasting benefits to the city. Working with state legislators, Sinclair received the go-ahead for the project. And, in keeping with his vision, the project employed men from Steubenville to build the facility.<sup>68</sup>

When the Steubenville Water Works was completed, Steubenville and Sinclair were faced with high numbers of unemployed men again, many of which sought out Sinclair for assistance. Sinclair began focusing on finding tenants for the Jefferson Iron Works, which had gone into receivership and closed, who would provide employment opportunities for citizens and help

---

<sup>63</sup> \_\_\_\_\_. "1900 - Vicinity of Follansbee in 1900," *Follansbee, WV – An Interactive Web History*, 19 Nov. 2012, [follansbeetimeline.com](http://follansbeetimeline.com), accessed 24 Feb. 2018.

<sup>64</sup> Recchie and Darbee, p 5.

<sup>65</sup> Ibid, p 6.

<sup>66</sup> Ibid, p 28.

<sup>67</sup> Baker, p 57.

<sup>68</sup> Ibid, pp 57-58.



Market Street Bridge

Name of Property

Brooke County, WV

County and State

Steubenville's growth. Sinclair persuaded Labelle Iron Works, who had just sold their Wheeling, West Virginia plant, to purchase the defunct iron works in Steubenville.<sup>69</sup> Shortly after Labelle made their purchase, Sinclair gave land to the Pope Tin Plate Company so they, too, would locate in Steubenville and become an additional source of employment.<sup>70</sup>

### *History of Follansbee, West Virginia*

A few months later, Mr. William Mahan, a land owner and farmer across the Ohio River in what would become the town of Follansbee, West Virginia, contacted Sinclair and informed him that the Mahan family would like to sell their large land holdings; they had stopped farming the land by 1902. William Mahan had purchased the Old Mingo Bottom in 1815 from the Wells family. The land has once been controlled by the Mingo Indians; the Mingo sold the land to Richard Wells for the sum of two bottles of red liquor. Mahan worked the land for 87 years during which time the property became known as Mahan Station or Mahan Village.<sup>71</sup>

Sinclair had recently been informed that the Follansbee Brothers of Pittsburgh, Pennsylvania were looking for property to develop and build a tin mill. Sinclair made contact with the brothers but was advised by them that Wheeling's Board of Trade had invited the duo to talk about locating their mill in that city. Sinclair invited them to stop in Steubenville on their return trip to Pittsburgh after their Wheeling visit; the brothers agreed to do so.<sup>72</sup> The following week, Sinclair met the brothers at the Middle Ferry Station on the West Virginia side to lead them on a tour of the immediate area.

Sinclair decided to keep Benjamin Gilbert Follansbee and his brother off the road to Mahan's property. The dirt wagon roads connecting the vicinity were narrow, often muddy, and frequently impassable, especially along the river banks. Instead the group traveled from Steubenville to Mingo via a street car. Across the river from the Mahan property sat the Mingo Iron Works and the Jefferson Furnace and Nail Works. B. Gilbert Follansbee stood on the Ohio River bank looking across at Mahan Village. "The backdrop of the area was breathtaking in its beauty. The rolling hills were dotted with the orchards of the Mahan family. Along the river laid the golden wheat fields, gently rippling in the breeze. At night the myriad of darting fireflies lent a Fairy Godmother glow over the entire area..."<sup>73</sup> Besides its beauty, the Mahan property was in an excellent location; it provided immediate access to the Ohio River and it was in close proximity to Pittsburgh's labor force.<sup>74</sup>

---

<sup>69</sup> Ibid, p 62.

<sup>70</sup> Ibid, pp 63-64.

<sup>71</sup> \_\_\_\_\_. "1815 – William Mahan Becomes Owner of Old Mingo Bottom," *Follansbee, WV – An Interactive Web History*, 1 Nov. 2012, follansbeetimeline.com, accessed 24 Feb. 2018.

<sup>72</sup> Baker, p 64.

<sup>73</sup> \_\_\_\_\_. "1900 – Vicinity of Follansbee in 1900," *Follansbee, WV – An Interactive Web History*, 1 Nov. 2012, follansbeetimeline.com, accessed 24 Feb. 2018.

<sup>74</sup> \_\_\_\_\_. "1902 – Follansbee Brothers Purchase Mahan's Farm," *Follansbee, WV – An Interactive Web History*, 1 Nov. 2012, follansbeetimeline.com, accessed 24 Feb. 2018.

Market Street Bridge  
Name of Property

Brooke County, WV  
County and State

The Follansbee brothers agreed to purchase 110 acres of orchards and farmland along the river from Thomas J. and Herman Mahan for the construction of their tin mill on one condition: Sinclair must assure them that both a streetcar line and a connecting bridge be established between Steubenville, Ohio and Wellsburg, West Virginia, which was south of Follansbee.<sup>75</sup>

Sinclair would ensure that the bridge, then referred to as the Steubenville Bridge, would be built if the brothers would build a tin mill on the West Virginia side of the river. Sinclair would also see that a hard surface road to Follansbee would be built in addition to a streetcar line from Steubenville, Ohio to Wellsburg, West Virginia. Sinclair would then provide trolley cars from his Tri-State Traction Company to carry workers across the river to the new mill. The tin mill, known as the Follansbee Steel Company, could then employ numerous Steubenville residents and thereby promote regional economic development.

Follansbee had a relatively small population in the early 1900's, and most of its inhabitants were already employed in other occupations (e.g., mills, glass-making, farming). In short, the labor demand in the immediate Follansbee area exceeded the available labor force.<sup>76</sup> The opposite was true in Steubenville where they had an abundance of unemployed men.

Sinclair began soliciting potential investors; if not for his streetcar company donating \$100,000 the bridge would not have been possible. With three friends (Mr. Alvin, John Donnan, and Mr. Kuntz) that agreed to invest in the project, Sinclair formed The Steubenville Bridge Company for the sole purpose of erecting a bridge across the Ohio River.<sup>77</sup> The eastern approach to the bridge would be built on land Sinclair already owned. At the age of 24, he purchased the West Virginia hillside across from Steubenville thinking that one day it would make a beautiful park for Steubenville residents.<sup>78</sup>

The bridge company chose the Ohio Steel Erection Company to construct the bridge. The framework would be created by the Penn Bridge Company, and the original steel was to be done by Jones and Laughlin Steel Company and Bethlehem Steel. E.K. Morse, a Pittsburgh consulting engineer, was the designer. Construction of the new Steubenville bridge began in early October 1903. Construction continued through 1904 and the first half of 1905.

Dedication of the bridge, the longest of its kind across the Ohio River at the time, occurred on July 2, 1905, and it opened to carry foot-traffic on the same day. Pedestrians paid 5¢ each to traverse the span (see Figure 9, next page). On July 3, 1905, light rail traffic in the form of trolley cars was permitted allowing one to journey between Steubenville, Ohio and either Wellsburg or Holliday's Cove, both in West Virginia.<sup>79</sup>

---

<sup>75</sup> Baker, p 65.

<sup>76</sup> Douglas Waugh, "Coketown - A Reconstructed History," *Brooke County, WV Genealogy*, 02 Dec. 1985, [brookecountywvgenealogy.org/coketown.html](http://brookecountywvgenealogy.org/coketown.html), accessed May 26, 2018.

<sup>77</sup> Baker, pp 65-66.

<sup>78</sup> Baker, p 102.

<sup>79</sup> Miller, Ryan, "Bridge turning 100 today," *Steubenville Herald Star*, Print. 02 Jul. 2005.

Market Street Bridge

Name of Property

Brooke County, WV

County and State



Figure 9: An original toll ticket found in a tool box by Paul W. Albaugh. (Courtesy Mike and Judy Lohr)

Follansbee became a city in 1906 and was a direct result of the agreement between the Follansbee brothers and Sinclair to build the Market Street Bridge. The Follansbee mill began operation by 1904, benefited from the construction of the bridge, as workers could easily commute to work by utilizing the structure. The mill has also played an important role in the local economy, employing as many as 1,500 employees by 1920.<sup>80</sup>

Mr. Sinclair next focused on bringing jobs to Holliday's Cove; the lifestyle of inhabitants there was in farming and small business.<sup>81</sup> Hearing that a tin mill was going to be built in Buffalo, New York by a Pittsburgh group, Mr. Sinclair arranged to be introduced to a few of the men and brought them to Steubenville to show them the areas available for the construction of a mill in the cove. Sinclair then made Ernest T. Weir an offer. If Weir would build his mill north of Holliday's Cove, then Sinclair would build a street car line from the new Market Street Bridge north to the mill. Mr. Weir, an industrialist from Pittsburgh, accepted the offer and purchased 105 acres of land and built a sheet steel plant named the Weirton Plant of the Phillips Sheet and Tin Plate Company.<sup>82</sup>

This access made possible by the construction of the Market Street Bridge was essential in building the local economy. The plant, which would eventually be named the Weirton Steel Company, would become the second largest tin plate producing mill in the country, bested only by U.S. Steel. In 1910, Weir began building a company town that he named Weirton.<sup>83</sup>

The bridge remains of high value and importance to local citizens and businesses on each side of the river, from both historical and practical perspectives. The communities of Follansbee, Weirton, and downtown Steubenville all rely heavily on this vital transportation link.<sup>84</sup>

<sup>80</sup> Wikipedia, "Market Street Bridge – Ohio River," [en.wikipedia.org/wiki/Market\\_Street\\_Bridge\\_\(Ohio\\_River\)](https://en.wikipedia.org/wiki/Market_Street_Bridge_(Ohio_River)), accessed 20 Jan 2018.

<sup>81</sup> "History of Weirton," Weirton, West Virginia, [cityofweirton.com/263/History-of-Weirton](http://cityofweirton.com/263/History-of-Weirton), accessed 13 Sept 2017.

<sup>82</sup> Baker, p 129.

<sup>83</sup> Wikipedia, "Ernest T. Weir," [en.wikipedia.org/wiki/Ernest\\_T.\\_Weir](https://en.wikipedia.org/wiki/Ernest_T._Weir), accessed 20 Jan. 2018.

<sup>84</sup> Lohr, p 8.

Market Street Bridge  
Name of Property

Brooke County, WV  
County and State

*Vital Transportation Link between West Virginia and Ohio*

The majority of Steubenville's early modes of transportation relied heavily on the river. "Ferries were an absolute necessity for any town located on a (river) that wished to grow and prosper."<sup>85</sup> Although operated privately, ferries were licensed by the government as an important public service.<sup>86</sup> The Middle Ferry at the eastern end of Market Street in downtown Steubenville was established by Richard "Gray Beard" Wells in 1799 to carry goods across the Ohio River. Gray Beard's relative, Bazil Wells, owned the land on the Ohio side where the ferry launched. Steubenville's rapid growth made the Middle Ferry very profitable for the Wells family; in 1836 Nathaniel Wells took charge of the ferry and continued managing the prosperous business for the family.<sup>87</sup>

Throughout the 19<sup>th</sup> century, the focus of transportation advancements changed from the river to the improvement of roads and streets; railroad lines specifically began to expand by the end of the 19<sup>th</sup> century. The Wheeling & Lake Erie Railroad extended to Steubenville in the 1890s.<sup>88</sup> East Steubenville served as a stop for the railroad between Holiday Cove and south to Mahan Station (Follansbee). Passengers leaving the train still had to use the ferry if they were traveling to Steubenville.<sup>89</sup> Even with the large transportation network Steubenville was privy to, unmet needs remained. The width of the Ohio River continued to be a major impediment to a connection being made between two neighboring states – separated by a river - and the communities that bordered the river; the need for a bridge was great.<sup>90</sup> A bridge would eliminate the cost of fuel to run the ferry, the cost of upkeep as well as the cost of labor (in the form of staff); provide a mechanism to cross the river in the winter (the ferry was forced to close due to ice, fog, etc.); eliminate the waiting time to cross the river; and, reduce travel time in crossing the river.<sup>91</sup>

The creation of the Market Street Bridge in the very early years of the 20<sup>th</sup> century expanded communication and opened access to new markets with an ease that could not have been conceived of in the era of ferrying. The historic bridge represents an important evolution in transportation and thereby access. It reduced the need for ferryboats while spanning the age of horse drawn wagons, streetcars, and today's auto traffic.<sup>92</sup> For these reasons, the Market Street Bridge is eligible for listing in the National Register of Historic Places under Criterion A: Transportation.

---

<sup>85</sup> Gerald W. Sutphin, "Ferries." e-WV: The West Virginia Encyclopedia. 13 August 2012. Web. 09 Aug 2018.

<sup>86</sup> Ibid.

<sup>87</sup> \_\_\_\_\_. "1904 - East Steubenville," *Follansbee, WV – An Interactive Web History*, 1 Nov. 2012, follansbeetimeline.com, accessed 24 Feb. 2018.

<sup>88</sup> Recchie and Darbee, p 46.

<sup>89</sup> "1904 – East Steubenville."

<sup>90</sup> Fint, p 5.

<sup>91</sup> "The Costs and Benefits of a Bridge," *Aguanomics: The political economy of water and other distractions*, 19 Aug 2013, <http://www.aguanomics.com/2013/08/the-costs-and-benefits-of-bridge.html>, accessed 03 Aug 2018.

<sup>92</sup> Fint, p 5.

Market Street Bridge  
Name of Property

Brooke County, WV  
County and State

### ***Criterion C: Design/Engineering***

*Engineer & Bridge Designer E.K. Morse*

The Steubenville Bridge Company hired civil engineer E.K. Morse to design the Market Street Bridge. Prior to this engagement, Morse had been involved in the 1887 construction of Australia's Hawkesburg River Railroad Bridge (no longer extant) which was the deepest structure in the world at the time and the largest railroad bridge in the Southern Hemisphere. Subsequently, he traveled back to the states and worked as a consulting engineer in Pittsburgh. Employers included Jones and Laughlin Steel Corporation, Carnegie Steel Corporation, local government entities, as well as the city of Pittsburgh as their flood control engineer, a position he held until his death in 1942. The bridge designer also had the opportunity to work with civil engineer John Roebling on the design of the Brooklyn Bridge in New York City.<sup>93</sup> Roebling was considered to be the most knowledgeable engineer of suspension bridges.<sup>94</sup>

The suspension bridge design was a favored design for vehicular crossings since a wide clear span with its high point in the center was ideal for avoiding interference with river traffic. Other benefits of the suspension bridge design include: longer spans, which are more achievable in suspension bridges than with any other type of bridge; less materials are required thus making the design more economical to construct (except for the installation of the initial temporary cables); little or no access from below is required during construction allowing a waterway to remain open while the bridge is built above; bridge decks can have individual deck sections replaced; and it may be better able to withstand greater earthquake movements than heavier and more rigid bridges.<sup>95</sup>

To further strengthen the bridge, Morse incorporated a truss system into his design for the Market Street Bridge. The Warren truss, a framework of connected parts forming equilateral triangular units, was patented in 1839 by James Warren. The truss can be used as a deck or a through truss. The triangles limit the force of the load to compression and tension of the bridge parts. The design results in no tie, strut or beam bending under the straining forces of a moving vehicle. Instead, the force from any vehicle will be focused on just one point directly below the vehicle. It is the top and bottom chords of the bridge that bear the larger forces when the load is at the center of the bridge.<sup>96</sup> Advantages in using a Warren truss included: (1) increased bridge strength, (2) fewer building materials needed, (3) less costly construction compared to conventional bridge design, and (4) unobstructed views.<sup>97</sup>

---

<sup>93</sup> "Market Street Bridge (Ohio River)"

<sup>94</sup> Wikipedia, "John A. Roebling," 12 May 2018, [https://en.wikipedia.org/wiki/John\\_A.\\_Roebling](https://en.wikipedia.org/wiki/John_A._Roebling), accessed 15 May 2018.

<sup>95</sup> Wikipedia, "Suspension bridge," 3 August 2018, [https://en.wikipedia.org/w/index.php?title=Suspension\\_bridge&oldid=853219738](https://en.wikipedia.org/w/index.php?title=Suspension_bridge&oldid=853219738), accessed 9 Aug. 2018.

<sup>96</sup> Garrett Boon, "Warren Truss" *Garrett's Bridges*, 28 Nov 1916, <https://www.garrettsbridges.com/design/warren-truss/>, accessed 20 Sep 2018.

<sup>97</sup> ScienceStruck Staff, "A Warren Truss Bridge," *ScienceStruck*, 19 Mar 2018, <https://sciencestruck.com/information-about-warren-truss-bridges>, accessed 20 Sep 2018.



Market Street Bridge  
Name of Property

Brooke County, WV  
County and State

Although the Charles Ellet, Jr.-designed antebellum Wheeling Suspension Bridge has also been subject to repairs (in order to strengthen the structure), it can be argued that the 1849 National Historic Landmark demonstrates the overall success of the design fundamentals of suspension bridges.<sup>98</sup> Morse's original design for the Market Street Bridge incorporated these same character-defining elements and concepts: a long center span (measuring 700 feet in length) flanked by shorter spans; the bridge's pared-down structural system comprised of two towers/piers, steel suspension cables, and the stabilizing truss (in this case, the aforementioned Warren truss); and, although documentation about the specifics of the original deck could not be located, it's assumed that the wood deck was laid in sections smaller than 700 feet in length (the length of the center span).

Although these key components have been subject to a degree of modification since 1905, the changes have not drastically strayed from Morse's original design. In addition, the changes to the bridge's character-defining features have not altered these structural design elements to the point where they no longer retain sufficient historic integrity to convey their significance and historic association.

*Dr. David B. Steinman's association with The Market Street Bridge*

Following the breaks in the top chord and its subsequent failure in 1922, renowned structural engineer Dr. David B. Steinman was called in by West Penn Traction Company to inspect and analyze the stability of the Market Street Bridge. Dr. Steinman attributed the structural failure to the overloaded freight cars that frequently crossed the bridge. Steinman made recommendations for the repairs and then subsequently redesigned the suspension span to accommodate heavier loads; the redesign was then implemented resulting in an increased carrying capacity of the bridge.

Although his work on the Market Street Bridge in the 1920s was some of Dr Steinman's earliest, who had come to be considered one of the most proficient and prolific bridge experts in the world.<sup>99</sup> In addition, his work on the Market Street Bridge laid the foundation for one of his best-known bridge building innovations: the open deck design.<sup>100</sup> Steinman incorporated this same deck design into the world-famous Mackinac Bridge in Michigan which was considered, at the time of its 1957 opening, the longest suspension bridge in the world. By the mid-1930s Steinman had gained a professional reputation as one of the pre-eminent bridge engineers of the US, especially for long-span suspension bridges.

As has been previously mentioned, the open steel grid deck was first used in the 1930's and was especially successful in bridge rehabilitation projects where weight reduction was necessary. Steinman obviously saw that that an open grid deck would be one solution to help with the

---

<sup>98</sup> Emory Kemp, Wheeling Suspension Bridge NRHP nomination, 1966, <http://www.wvculture.org/shpo/nr/pdf/ohio/70000662.pdf>, accessed 11/5/2018.

<sup>99</sup> Lohr, p.3.

<sup>100</sup> Ibid.

Market Street Bridge

Name of Property

Brooke County, WV

County and State

bridge's issues with weight loads. Steinman's acumen and expertise of the long-span suspension bridge helped to secure the bridge's structural stability and capacity into the 21<sup>st</sup> century.

*Engineering Design:*

The triple span suspension bridge with a Warren truss is a graceful illustration of Morse's talent fulfilled. It is a nostalgic reminder of the early years when Steubenville, Follansbee and Weirton were growing into the cities they would become. With design inspiration dating as far back as antiquity, the suspension bridge was not used for large-scale civil projects in the United States until the 19<sup>th</sup> century. Design theories about the suspension bridge promulgated throughout Europe and the United State in the late 18<sup>th</sup> and early 19<sup>th</sup> centuries. However, those theories were not put into practice until the late 19<sup>th</sup> century with the onset of widespread development of the iron and steel manufacturing technologies. These technologies allowed the economically efficient production of metal cables and structural members thereby economically facilitating the use of the suspension bridge design to span great lengths while employing less building material.

Charles Ellet, Jr. and John A. Roebling studied suspension bridge design while in Europe and were instrumental in its dissemination in the United States. As previously mentioned, Ellet designed and oversaw the construction of the Wheeling Suspension Bridge until its completion in 1849. It is regarded as one of the most significant historic suspension bridges in the United States. The suspension type of bridge was a favored design for vehicular crossings along the Ohio, since a wide clear span with its high point in the center was ideal for avoiding interference with river traffic.<sup>101</sup> The suspension bridge became widely used at multiple spans across the Ohio River crossing into West Virginia: East Liverpool-Chester Bridge (1897); Newell-East Liverpool Bridge (1905), Belpre-Parkersburg Bridge (1916), and Fort Steuben Bridge (1928), among others.<sup>102</sup>

The Market Street Bridge is one of the few examples of a bridge with Warren truss still remaining in the United States.<sup>103</sup> Although the Market Street Bridge has been rehabilitated and reinforced since its completion in 1905, the structure is sufficiently intact and retains a high degree of historic integrity, enabling it to convey its historic associations in both transportation and engineering. The Market Street Bridge remains a locally significant example of its type and is eligible for listing in the National Register of Historic Places under Criterion C: Engineering.

---

<sup>101</sup> Recchie, p.54.

<sup>102</sup> Fint, 2009.

<sup>103</sup> Wikipedia, "Truss bridge", 7 April 2010,  
[https://en.wikipedia.org/w/index.php?title=Truss\\_bridge&oldid=849662170](https://en.wikipedia.org/w/index.php?title=Truss_bridge&oldid=849662170), accessed 4 Apr. 2018.

Market Street Bridge  
Name of Property

Brooke County, WV  
County and State

---

## 9. Major Bibliographical References

**Bibliography** (Cite the books, articles, and other sources used in preparing this form.)

**See Continuation Sheet**

---

### Previous documentation on file (NPS):

- preliminary determination of individual listing (36 CFR 67) has been requested
- previously listed in the National Register
- previously determined eligible by the National Register
- designated a National Historic Landmark
- recorded by Historic American Buildings Survey # \_\_\_\_\_
- recorded by Historic American Engineering Record # \_\_\_\_\_
- recorded by Historic American Landscape Survey # \_\_\_\_\_

### Primary location of additional data:

- State Historic Preservation Office
  - Other State agency
  - Federal agency
  - Local government
  - University
  - Other
- Name of repository: WV Department of Transportation

### Historic Resources Survey Number (if assigned):

---

## 10. Geographical Data

**Acreeage of Property** 1.31 acres

Use either the UTM system or latitude/longitude coordinates

### Latitude/Longitude Coordinates (decimal degrees)

Datum if other than WGS84: \_\_\_\_\_  
(enter coordinates to 6 decimal places)

- 1. Latitude: \_\_\_\_\_ Longitude: \_\_\_\_\_
- 2. Latitude: \_\_\_\_\_ Longitude: \_\_\_\_\_

Market Street Bridge  
Name of Property

Brooke County, WV  
County and State

3. Latitude: Longitude:  
4. Latitude: Longitude:

**Or**  
**UTM References**

Datum (indicated on USGS map):

NAD 1927 or  NAD 1983

- |              |                 |                   |
|--------------|-----------------|-------------------|
| 1. Zone: 17N | Easting: 533409 | Northing: 4467498 |
| 2. Zone: 17N | Easting: 533149 | Northing: 4467598 |
| 3. Zone: 17N | Easting: 532896 | Northing: 4467698 |
| 4. Zone:     | Easting:        | Northing:         |

**Verbal Boundary Description** (Describe the boundaries of the property.)

Beginning at a point in the center line of Market Street in the City of Steubenville, Ohio, projected across the Ohio River, sixty feet East of the eastern property line of the Pittsburgh, Wheeling and Kentucky Railway Company, thence parallel with the said Eastern property line of the said Railway Company, S 18° 24' W 85.0 feet to a point, thence N 68° 36' W 420.0 feet more or less crossing the Railroad to a low water mark in the Ohio River, thence up the Ohio River N 18° 24' E 150.0 feet to a point in said low water mark, thence S 68° 36' E 420.0 feet more or less point crossing the Railroad to a point sixty feet east of the Eastern property line of the above mentioned Railroad, thence S 18° 24' W 65.0 feet to the beginning, containing 1 31/100 acres.

Being a strip of ground 150.0 feet in width, 65.0 feet North of and 85.0 feet south of the extension of the center line of said Market Street, parallel and Equidistant from said Market Street center line projected, 420.0 feet more or less to low water mark in the Ohio River, including the buildings and other improvements located on said strip of ground.

**Boundary Justification** (Explain why the boundaries were selected.)

The selected boundaries were determined by the terms of the 1941 deed recorded in Brooke County Deed Book #74, Pages 513 to 516. All of the elements historically associated with the Market Street Bridge are included within the defined boundary.

Market Street Bridge  
Name of Property

Brooke County, WV  
County and State

---

### 11. Form Prepared By

name/title: Dr. Kathy Kidder-Wilkerson  
organization: Market Street Bridge Preservation Committee (Anthony Paesano, Chairman, Marty Bartz and Kathy Kidder-Wilkerson)  
street & number: 932 Donegal Drive East  
city or town: Follansbee state: WV zip code: 26037  
e-mail kwilkerson1312@comcast.net  
telephone: 304-794-6858  
date: June 10, 2018

---

### Additional Documentation

Submit the following items with the completed form:

- **Maps:** A **USGS map** or equivalent (7.5 or 15 minute series) indicating the property's location.
- **Sketch map** for historic districts and properties having large acreage or numerous resources. Key all photographs to this map.
- **Additional items:** (Check with the SHPO, TPO, or FPO for any additional items.)



Market Street Bridge  
Name of Property

Brooke County, WV  
County and State

### Photographs

Submit clear and descriptive photographs. The size of each image must be 1600x1200 pixels (minimum), 3000x2000 preferred, at 300 ppi (pixels per inch) or larger. Key all photographs to the sketch map. Each photograph must be numbered, and that number must correspond to the photograph number on the photo log. For simplicity, the name of the photographer, photo date, etc. may be listed once on the photograph log and doesn't need to be labeled on every photograph.

### Photo Log

Name of Property:

City or Vicinity:

County:

State:

Photographer:

Date Photographed:

Description of Photograph(s) and number, include description of view indicating direction of camera:

1 of \_\_\_\_.

### See Continuation Sheets

**Paperwork Reduction Act Statement:** This information is being collected for applications to the National Register of Historic Places to nominate properties for listing or determine eligibility for listing, to list properties, and to amend existing listings. Response to this request is required to obtain a benefit in accordance with the National Historic Preservation Act, as amended (16 U.S.C.460 et seq.).

**Estimated Burden Statement:** Public reporting burden for this form is estimated to average 100 hours per response including time for reviewing instructions, gathering and maintaining data, and completing and reviewing the form. Direct comments regarding this burden estimate or any aspect of this form to the Office of Planning and Performance Management, U.S. Dept. of the Interior, 1849 C. Street, NW, Washington, DC.

**United States Department of the Interior**  
National Park Service

**National Register of Historic Places**  
**Continuation Sheet**

Market Street Bridge
----- Name of Property
Brooke County, WV
----- County and State
N/A
----- Name of multiple listing (if applicable)

Section number   9   Page       1      

**Major Bibliographical References**

- “1878 – Passengers Describe Train Trip to Mahan’s Farm.” *Follansbee, WV – An Interactive Web History*. <http://follansbeetimeline.com/>. Accessed 24 Feb. 2018.
- “1900 - Vicinity of Follansbee in 1900.” *Follansbee, WV – An Interactive Web History*. <http://follansbeetimeline.com/>. Accessed 24 Feb. 2018.
- “1904 – Follansbee Brothers tin plate and sheet steel mills 1904.” *Follansbee, WV – An Interactive Web History*. <http://follansbeetimeline.com/>. Accessed 24 Feb. 2018.
- Aguanomics: The political economy of water- and other distractions. “The Costs and Benefits of a Bridge.” <http://www.aguanomics.com/2013/08/the-costs-and-benefits-of-bridge.html>. Accessed 03 Aug 2018.
- Baker, Wilma. *Father and His Town*. Pittsburgh: Three Rivers Press. 1961.
- Boon, Garrett. *Garrett’s Bridges*. <https://www.garrettsbridges.com/design/warren-truss/>. Accessed 20 September 2018.
- Bridges and Tunnels.com. “Market Street Bridge.” [bridgestunnels.com/bridges/ohio-river/market-street-bridge/](http://bridgestunnels.com/bridges/ohio-river/market-street-bridge/). Accessed 07 Dec. 2017.
- Brown, John, “Our Ohio River bridges: The past, the present, the future.” *The Steubenville Herald Star*. Courtesy Public Library of Steubenville and Jefferson County.
- Burgess & Niple, Inc. “Bridge Inspection Report.” Parkersburg, WV: Burgess & Niple. June 2015.
- Chavel, Ph. D, PE, Brandon. “Steel Bridge Design Handbook. Bridge Deck Design.” U.S. Department of Transportation. Federal Highway Administration. Publication No. FHWA-IF-12-052-Vol.17. November 2012. <https://www.fhwa.dot.gov/bridge/steel/pubs/if12052/volume17.pdf>. Accessed 5 Nov. 2018.
- Day, Sandy and Alan Hall. *Steubenville Bicentennial 1797-1997*. Steubenville Bicentennial Book Committee. Unpublished manuscript. Public Library of Steubenville and Jefferson County.
- Encyclopaedia Britannica. “Pier.” [britannica.com/technology/pier-architecture](http://britannica.com/technology/pier-architecture). Accessed 27 Apr. 2018.
- Fint, Courtney. “West Virginia Historic Property Inventory Form.” <http://services.wvgis.wvu.edu/SHPOdocs/PDFs/ArchitecturalSites/BR-0067.pdf>. Accessed 10 April 2009.

**United States Department of the Interior**  
National Park Service

**National Register of Historic Places**  
**Continuation Sheet**

Market Street Bridge
-----
Name of Property
Brooke County, WV
-----
County and State
N/A
-----
Name of multiple listing (if applicable)

Section number   9   Page       2      

Florio, Michael. "Mill Towns Steubenville, Ohio." [michaelfroio.com/blog/2014/02/03/mill-towns-steubenville-ohio](http://michaelfroio.com/blog/2014/02/03/mill-towns-steubenville-ohio). Accessed 15 May 2018.

"Fort Steuben." <http://oldfortsteuben.com/attractions.php#fort>. Accessed 11 Nov. 2018.

Glasser, Adrien. Telephone interview with Dr. Kathy Kidder-Wilkerson, July 25, 2018.

Hall, Alan. "Market Street Bridge," *Director's Column*. Public Library of Steubenville and Jefferson County, 15 Mar. 2009.

"History of Weirton, West Virginia," [cityofweirton.com/263/History-of-Weirton](http://cityofweirton.com/263/History-of-Weirton). Accessed 13 Sept. 2017.

Holth, Nathan. "An Introduction to Historic Bridges." (website feature presentation slide 183). <https://historicbridges.org/index.htm>. Accessed 03 Apr. 2018.

Kemp, Emory. Wheeling Suspension Bridge National Register of Historic Places nomination, 1966. <http://www.wvculture.org/shpo/nr/pdf/ohio/70000662.pdf>. Accessed 5 Nov. 2018.

Lewellyn, Matthew et al. "Revitalization of an Ohio River Suspension Bridge." [burgessniple.com/content/papers/revitalization-of-an-ohio-river-suspension-bridge.pdf](http://burgessniple.com/content/papers/revitalization-of-an-ohio-river-suspension-bridge.pdf). Accessed 28 Jan. 2018.

Lichtenberger Engineering Library, University of Iowa. "Glossary of Bridge Terminology." <http://sdr.lib.uiowa.edu/eng/bridges/WaddellGlossary/GlossR.htm>. Accessed 18 April 2018.

Linzell, Daniel and Chandana C. Balakrishna (*Nebraska Transportation Center*). "Steel Pin and Hanger Assembly Replacement Options." p 10, Jan. 2017. [atc.unl.edu/assets/documents/matcfinal/Linzell\\_SteelPinandHangerAssemblyReplacementOptions.pdf](http://atc.unl.edu/assets/documents/matcfinal/Linzell_SteelPinandHangerAssemblyReplacementOptions.pdf). Accessed 28 Mar. 2018.

Lohr, Mike and Judy, "A Short History of the Steubenville (Market Street) Bridge." [jeffcochapter.com/SteubenvilleTwp/History/A%20Short%20History%20of%20The%20Steubenville%20Bridge.pdf](http://jeffcochapter.com/SteubenvilleTwp/History/A%20Short%20History%20of%20The%20Steubenville%20Bridge.pdf). Accessed 11 Nov. 2017.

"Market Street Bridge to Remain Open." *WTOV9*. [wtov9.com/print/18539418/detail.html](http://wtov9.com/print/18539418/detail.html). Accessed 24 Feb. 2018.

Merrimam-Webster Dictionary. "Retrofit." [merriam-webster.com/dictionary/retrofit](http://merriam-webster.com/dictionary/retrofit). Accessed 1 Jun. 2018.

Missouri Department of Transportation. "Safe and Sound Bridge Terminology."

**United States Department of the Interior**  
National Park Service

**National Register of Historic Places**  
**Continuation Sheet**

Market Street Bridge
-----
Name of Property
Brooke County, WV
-----
County and State
N/A
-----
Name of multiple listing (if applicable)

Section number   9   Page       3      

[modot.org/northeast/documents/10-12-22SASbridgeterminology.pdf](http://modot.org/northeast/documents/10-12-22SASbridgeterminology.pdf). Accessed 20 Sep. 2018.

Ohio Department of Transportation. "Historic Bridge Survey Report."  
<https://historicbridges.org/ohio/market/hbisheet.pdf>. Accessed 27 Apr. 2018.

Recchie, Nancy and Jeffrey Darbee (Steubenville Historic Landmarks Commission). "Steubenville Historic Contexts and Resource Evaluation." Aug. 1993, p 11, [cityofsteubenville.us/wp-content/uploads/2013/07/Steubenville-Historic-Contexts-Resource-Evaluation.pdf](http://cityofsteubenville.us/wp-content/uploads/2013/07/Steubenville-Historic-Contexts-Resource-Evaluation.pdf). Accessed 15 Apr. 2018.

ScienceStruck. "A Warren Truss Bridge." 19 Mar 2018, <https://sciencestruck.com/information-about-warren-truss-bridges>. Accessed 20 Sep 2018.

Snedden, Jeff. "Penn Bridge Co. and others put Beaver Falls on the Map." *The Times*, 15 Aug. 2017.

Socratic. "How does thermal expansion affect bridges?"  
<https://socratic.org<physics<heat<thermalexpansion>. Accessed 25 Jul. 2018.

"Timeline," *Follansbee, WV – An Interactive Web History*, 19 Nov. 2012, [follansbeetimeline.com](http://follansbeetimeline.com). Accessed 24 Feb. 2018.

U.S. Department of Interior National Park Service National Register of Historic Places. "How to Apply the National Register Criteria for Evaluation."  
[nps.gov/nr/publications/bulletins/nrb15/Index.htm](http://nps.gov/nr/publications/bulletins/nrb15/Index.htm). Accessed 24 Mar. 2018.

Waugh, Douglas, "Coketown – A Reconstructed History," *Brooke County, WV Genealogy*, 02 Dec 1985, [brookecountywvgenealogy.org/coketown.html](http://brookecountywvgenealogy.org/coketown.html). Accessed 24 May 2018.

WebCorr Corrosion Consulting Services. "Different Types of Corrosion."  
[corrosionclinic.com/types\\_of\\_corrosion/crevice\\_corrosion.htm](http://corrosionclinic.com/types_of_corrosion/crevice_corrosion.htm). Accessed 28 Mar. 2018.

West Virginia Department of Transportation. "Market Street Bridge Inventory Report." 2012. (received via email from spierce to kkidder, 2017)

"Wheeling Suspension Bridge Has Special Place in History," *The Intelligencer*, 28 Nov. 2017, [theintelligencer.net/news/community/2017/11/wheeling-suspension-bridge-has-special-place-in-history/](http://theintelligencer.net/news/community/2017/11/wheeling-suspension-bridge-has-special-place-in-history/) Accessed 08 Jun. 2018.

Wikipedia, The Free Encyclopedia. "Bethlehem Steel." [https://en.wikipedia.org/wiki/Bethlehem\\_Steel](https://en.wikipedia.org/wiki/Bethlehem_Steel). Accessed 1 Jun. 2018.

Wikipedia, The Free Encyclopedia. "Ernest T. Weir." [en.wikipedia.org/wiki/Ernest\\_T.\\_Weir](http://en.wikipedia.org/wiki/Ernest_T._Weir). Accessed 20 Jan. 2018.

**United States Department of the Interior**  
National Park Service

**National Register of Historic Places**  
**Continuation Sheet**

Market Street Bridge
-----
Name of Property
Brooke County, WV
-----
County and State
N/A
-----
Name of multiple listing (if applicable)

Section number   9   Page       4      

---

Wikipedia, The Free Encyclopedia. "John A. Roebling." [en.wikipedia.org/wiki/John\\_A.\\_Roebling](https://en.wikipedia.org/wiki/John_A._Roebling). Accessed 15 May 2018.

Wikipedia, The Free Encyclopedia. "Market Street Bridge (Ohio River)." [en.wikipedia.org/w/index.php?title=Market\\_Street\\_Bridge\\_\(Ohio\\_River\)&oldid=824194595](https://en.wikipedia.org/w/index.php?title=Market_Street_Bridge_(Ohio_River)&oldid=824194595). Accessed 11 Nov. 2018.

Wikipedia, The Free Encyclopedia. "Pier (architecture)." [en.wikipedia.org/w/index.php?title=Pier\\_\(architecture\)&oldid=830173946](https://en.wikipedia.org/w/index.php?title=Pier_(architecture)&oldid=830173946). Accessed 27 Apr. 2018.

Wikipedia, The Free Encyclopedia. "Suspension Bridge." [https://en.wikipedia.org/w/index.php?title=Suspension\\_bridge&oldid=853219738](https://en.wikipedia.org/w/index.php?title=Suspension_bridge&oldid=853219738). Accessed 9 Aug. 2018.

Wikipedia, The Free Encyclopedia. "Truss bridge." [en.wikipedia.org/wiki/Truss\\_bridge](https://en.wikipedia.org/wiki/Truss_bridge). Accessed 7 Apr. 2018.

WisDOT. "Abutments." *Bridge Manual*, Jan. 2018, p 12-3, [wisconsindot.gov/dtsdManuals/strct/manuals/bridge/ch12.pdf](https://wisconsindot.gov/dtsdManuals/strct/manuals/bridge/ch12.pdf). Accessed 07 Jan. 2018.

"WVDOH Plans Major Maintenance Work on Market Street Bridge." West Virginia Department of Transportation. 31 July 2009.

**United States Department of the Interior**  
National Park Service

**National Register of Historic Places**  
**Continuation Sheet**

Market Street Bridge
Name of Property
Brooke County, WV
County and State
N/A
Name of multiple listing (if applicable)

Section number     Photos     Page     1    

Photo Log

Name of Property: Market Street Bridge  
City or Vicinity: Follansbee vicinity  
County: Brooke  
State: West Virginia  
Photographer: Marty Bartz  
Date Photographed: 2017 & 2018 (as noted)

- Photo 1 of 11: Market Street Bridge, taken from WV side, southeast of bridge, 6 Nov 2017
- Photo 2 of 11: Market Street Bridge, taken from WV side, southeast of bridge, 3 Jan 2018
- Photo 3 of 11: Market Street Bridge, taken Fort Steuben, Ohio, southwest of bridge, 6 Nov 2017
- Photo 4 of 11: Market Street Bridge, night view, taken from WV side, northwest of bridge, 1 Jan 2018
- Photo 5 of 11: The Honorable Joe Manchin (left) and Follansbee Mayor Anthony Paesano at ARRA Funds Press Conference, taken from WV side, southeast of bridge, ca.2011
- Photo 6 of 11: Market Street Bridge, handrail leading to pedestrian walk, facing NE, taken from WV side, 26 July 2018
- Photo 7 of 11: Market Street Bridge, handrail & stair landing, lighting under handrail cap, facing south, 26 July 2018
- Photo 8 of 11: Market Street Bridge, pedestrian walk, downstream side of bridge, facing east, 26 July 2018
- Photo 9 of 11: Market Street Bridge, Approach from WV side of the Ohio River, facing west, 12 August 2018
- Photo 10 of 11: Market Street Bridge, Approach from OH side of the Ohio River, facing east, 12 August 2018
- Photo 11 of 11: Market Street Bridge, western side of the Ohio tower, facing east, 12 August 2018



**United States Department of the Interior**  
National Park Service

**National Register of Historic Places**  
**Continuation Sheet**

Market Street Bridge
Name of Property
Brooke County, WV
County and State
N/A
Name of multiple listing (if applicable)

Section number      Photos      Page     2    



Photo 1: Market Street Bridge, Facing NW, standing on WV side of Ohio River



Photo 2: Market Street Bridge, Facing NW, standing on WV side of Ohio River



**United States Department of the Interior**  
National Park Service

**National Register of Historic Places**  
**Continuation Sheet**

Market Street Bridge
Name of Property
Brooke County, WV
County and State
N/A
Name of multiple listing (if applicable)

Section number      Photos      Page     3    



Photo 3: Market Street, Facing SE, taken while standing at Fort Steuben, Ohio



Photo 4: Market Street Bridge, Facing SW, night view, taken from WV side of Ohio River

**United States Department of the Interior**  
National Park Service

**National Register of Historic Places**  
**Continuation Sheet**

Market Street Bridge
Name of Property
Brooke County, WV
County and State
N/A
Name of multiple listing (if applicable)

Section number      Photos      Page     4    



Photo 5: US Sen. Joe Manchin & Follansbee Mayor Anthony Paesano, facing NW



Photo 6: Market Street Bridge, Handrail leading to Pedestrian Walk, facing NE



**United States Department of the Interior**  
National Park Service

**National Register of Historic Places**  
**Continuation Sheet**

Market Street Bridge
Name of Property
Brooke County, WV
County and State
N/A
Name of multiple listing (if applicable)

Section number      Photos      Page     5    



Photo 7: Market Street Bridge, Handrail & Stair landing, Note lighting under Handrail Cap, facing South



Photo 8: Market Street Bridge, Pedestrian Walk on Downstream side, Note lighting under Handrail Cap, facing East

United States Department of the Interior  
National Park Service

National Register of Historic Places  
Continuation Sheet

Market Street Bridge
Name of Property
Brooke County, WV
County and State
N/A
Name of multiple listing (if applicable)

Section number      Photos      Page     6    



Photo 9: Market Street Bridge, approach on the WV (eastern) side of the river, facing west



Photo 10: Market Street Bridge, approach on the Ohio (western) side of the river, facing east



**United States Department of the Interior**  
National Park Service

**National Register of Historic Places**  
**Continuation Sheet**

Market Street Bridge
Name of Property
Brooke County, WV
County and State
N/A
Name of multiple listing (if applicable)

Section number      Photos      Page     7    

---



Photo 11: Market Street Bridge, Detail of the western side of the Ohio tower, facing east

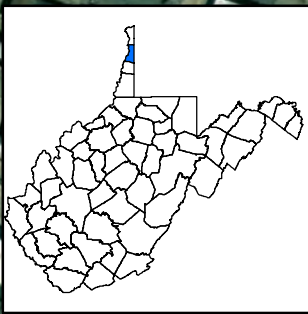

▲ Photo Location  
▭ Property Boundary  
- - - State Boundary

0 250 500 1,000 Feet

Source: Esri, DigitalGlobe, GeoEye, Earthstar Geographics, CNES/Airbus DS, USDA, USGS, AEX, Getmapping, Aerogrid, IGN, IGP, swisstopo, and the GIS User Community

Acres: 1.32  
Quad: Steubenville  
Date: 9/5/2018

# Market Street Bridge

## Photo Log

Brooke County - West Virginia





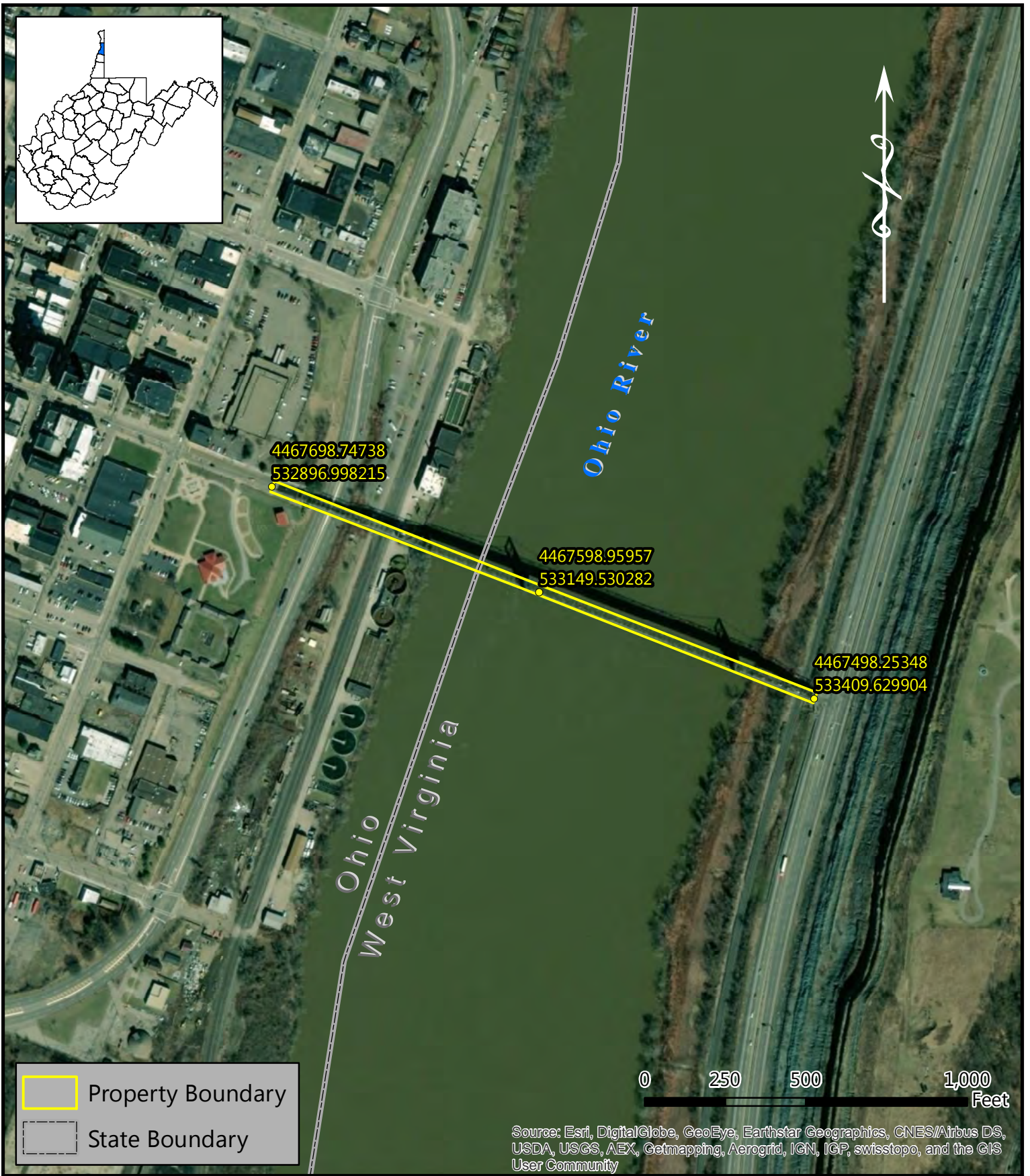
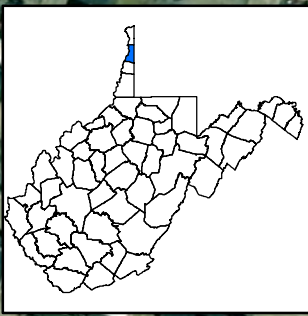

 Property Boundary

 State Boundary

Source: Esri, DigitalGlobe, GeoEye, Earthstar Geographics, CNES/Airbus DS, USDA, USGS, AEX, Getmapping, Aerogrid, IGN, IGP, swisstopo, and the GIS User Community

Acres: 1.32  
Quad: Steubenville  
Date: 9/5/2018

# Market Street Bridge

Brooke County - West Virginia





# Market Street Bridge - USGS Topo Map



August 27, 2018

1:18,056

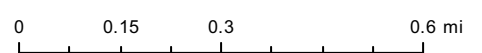

- ◆ Architecture Sites - Point
- ◆ Restricted National Register - Point
- Civil War Sites
- Cemeteries - Point
- ◆ Architecture Sites - Area
- ◆ Restricted National Register - Area

- ◆ Civil War Battlefields
- ◆ Cemeteries - Area
- ◆ Architecture Survey - Area

**Notes:**

Market Street Bridge  
 WV Route 2 spur, Mile Post 0.01  
 Follansbee (vic.), WV  
 Brooke County

Public Roads Div.	State Dist. No.	State Project No.	Federal Project No.	Fiscal Year	County	Sheet No.	Total Sheets
W. V.	6	S305-P2-0.01 00	ERP-0002 (487)D	2009	BROOKE	A1	A35

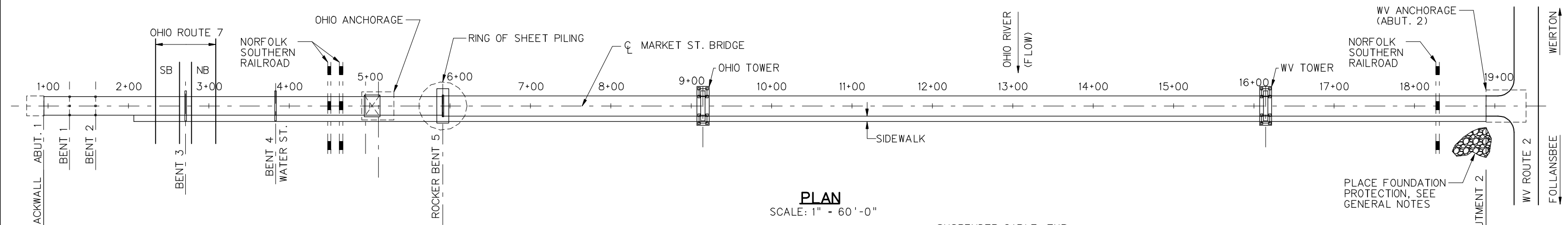

**PLAN**  
SCALE: 1" = 60'-0"

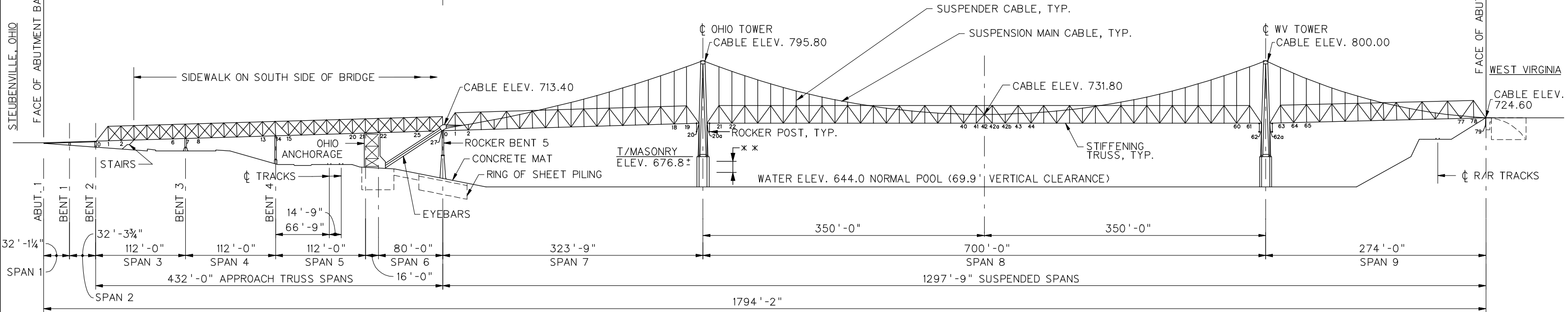

**ELEVATION**  
SCALE: 1" = 60'-0"

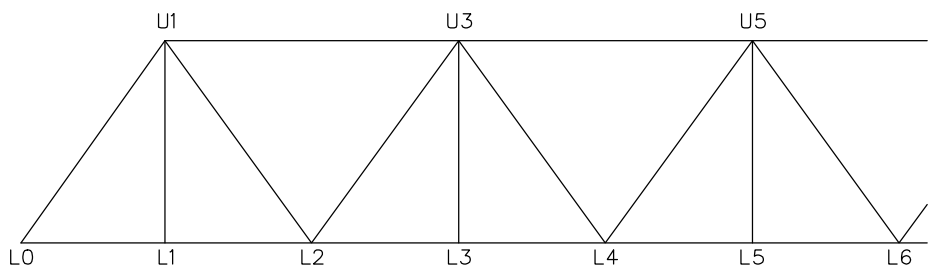

TYPICAL TRUSS NOTATION

\* \* HYDRAULIC DATA:

500 YR WATER SURFACE ELEVATION	= 675.6
100 YR WATER SURFACE ELEVATION	= 670.2
50 YR WATER SURFACE ELEVATION	= 667.8
10 YR WATER SURFACE ELEVATION	= 662.0

REVISION NUMBER	SHEET NUMBER	REVISION	DATE	BY

THE WEST VIRGINIA DEPARTMENT OF TRANSPORTATION  
DIVISION OF HIGHWAYS

## MARKET STREET BRIDGE

### GENERAL PLAN AND ELEVATION

DESIGNED: MWL 6/09  
DRAWN: DCA 6/09  
CHECKED: SJA 8/09  
CHECKED: [ ]

SHEET OF  
BRIDGE NO. 1664.1

PARKERSBURG, WV **BURGESS & NIPLÉ**













HISTORIC FORT STEUBEN  
SCENIC BYWAY  
VISITOR CENTER









203  
2A  
250

SPEED  
LIMIT  
25

















WEIGHT  
LIMIT  
5  
TONS

SPEED  
LIMIT  
25





WEIGHT  
LIMIT  
5  
TONS

SPEED  
LIMIT  
25







UNITED STATES DEPARTMENT OF THE INTERIOR  
NATIONAL PARK SERVICE

NATIONAL REGISTER OF HISTORIC PLACES  
EVALUATION/RETURN SHEET

Requested Action:

Property Name:

Multiple Name:

State & County:

Date Received: 2/5/2019      Date of Pending List: 2/28/2019      Date of 16th Day: 3/15/2019      Date of 45th Day: 3/22/2019      Date of Weekly List: 3/22/2019

Reference number:

Nominator:

Reason For Review:

- |   |  |   |
|---|--|---|
| <input type="checkbox"/> Appeal           | <input type="checkbox"/> PDIL            | <input type="checkbox"/> Text/Data Issue    |
| <input type="checkbox"/> SHPO Request     | <input type="checkbox"/> Landscape       | <input type="checkbox"/> Photo              |
| <input type="checkbox"/> Waiver           | <input type="checkbox"/> National        | <input type="checkbox"/> Map/Boundary       |
| <input type="checkbox"/> Resubmission     | <input type="checkbox"/> Mobile Resource | <input type="checkbox"/> Period             |
| <input checked="" type="checkbox"/> Other | <input type="checkbox"/> TCP             | <input type="checkbox"/> Less than 50 years |
|   | <input type="checkbox"/> CLG             |   |

Accept       Return       Reject      3/21/2019 Date

Abstract/Summary  
Comments:

Recommendation/  
Criteria

Reviewer Barbara Wyatt      Discipline Historian

Telephone (202)354-2252      Date \_\_\_\_\_

DOCUMENTATION:    see attached comments : No    see attached SLR : No

If a nomination is returned to the nomination authority, the nomination is no longer under consideration by the National Park Service.



January 15, 2019

**The Culture Center**  
1900 Kanawha Blvd., E.  
Charleston, WV 25305-0300

**Randall Reid-Smith, Commissioner**

Phone 304.558.0220 • www.wvculture.org  
Fax 304.558.2779 • TDD 304.558.3562

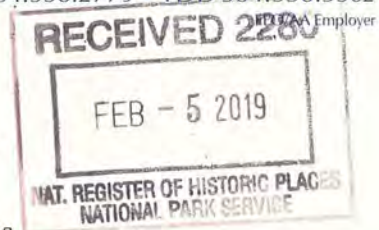

Ms. Joy Beasley, Keeper  
National Register of Historic Places and National Historic Landmark Programs  
National Park Service  
1849 C Street NW  
Mail Stop 7228  
Washington, DC 20240

Dear Ms. Beasley:

For your review, we are submitting National Register of Historic Places registration forms for the following properties:

*Market Street Bridge, Brooke County, West Virginia/Jefferson County, Ohio*  
*New Deal Resources in Babcock State Park, Fayette County, West Virginia*

These nominations have been processed in accordance with 36 C.F.R. § 60 and approved by the West Virginia Archives and History Commission. **The enclosed discs contain the true and correct copies of the nominations for the abovementioned properties for listing in the National Register of Historic Places.**

Should you have any questions please contact Jeffrey S. Smith, National Register Coordinator, at 304.558.0240, extension 121.

Sincerely,

Susan M. Pierce  
Deputy State Historic Preservation Officer

Enclosures

SMP/JSS