

NATIONAL HISTORIC LANDMARK NOMINATION

NPS Form 10-900

USDI/NPS NRHP Registration Form (Rev. 8-86)

OMB No. 1024-0018

THOMAS GAFF HOUSE (Hillforest)

United States Department of the Interior, National Park Service

Page 1

National Register of Historic Places Registration Form

1. NAME OF PROPERTY

Historic Name: Thomas Gaff House

Other Name/Site Number: Hillforest

2. LOCATION

Street & Number: 213 Fifth Street Not for publication:___

City/Town: Aurora Vicinity:___

State: IN County: Dearborn Code: 18 Zip Code: 47001

3. CLASSIFICATION

Ownership of Property	Category of Property
Private: <u>X</u>	Building(s): <u>X</u>
Public-local: ___	District: ___
Public-State: ___	Site: ___
Public-Federal: ___	Structure: ___
	Object: ___

Number of Resources within Property	Noncontributing
Contributing	
<u>1</u>	<u>1</u> buildings
<u>2</u>	sites
<u>3</u>	structures
	objects
	<u>1</u> Total

Number of Contributing Resources Previously Listed in the National Register: 3

Name of related multiple property listing: _____

THOMAS GAFF HOUSE (Hillforest)

United States Department of the Interior, National Park Service

National Register of Historic Places Registration Form

4. STATE/FEDERAL AGENCY CERTIFICATION

As the designated authority under the National Historic Preservation Act of 1986, as amended, I hereby certify that this _____ nomination _____ request for determination of eligibility meets the documentation standards for registering properties in the National Register of Historic Places and meets the procedural and professional requirements set forth in 36 CFR Part 60. In my opinion, the property _____ meets _____ does not meet the National Register Criteria.

Signature of Certifying Official

Date

State or Federal Agency and Bureau

In my opinion, the property _____ meets _____ does not meet the National Register criteria.

Signature of Commenting or Other Official

Date

State or Federal Agency and Bureau

5. NATIONAL PARK SERVICE CERTIFICATION

I, hereby certify that this property is:

- Entered in the National Register _____
Determined eligible for the _____
National Register
- Determined not eligible for the _____
National Register
- Removed from the National Register _____
- Other (explain): _____

Signature of Keeper

Date of Action

THOMAS GAFF HOUSE (Hillforest)

United States Department of the Interior, National Park Service

Page 3

National Register of Historic Places Registration Form

6. FUNCTION OR USE

Historic: Domestic

Sub: Single Dwelling

Current: Recreation

Sub: Museum

NHL Criteria XVI**7. DESCRIPTION**

Architectural Classification:

Mid-19th Century: Italian Villa

Materials:

Foundation:

Stone

Walls:

Wood (cypress)

Roof:

Tar

Other:

Cast iron (railings)

THOMAS GAFF HOUSE (Hillforest)

United States Department of the Interior, National Park Service

Page 4

National Register of Historic Places Registration Form

Describe Present and Historic Physical Appearance.

This mid-19th century estate, called Hillforest, on the Ohio River was commissioned by a river boat owner, Thomas Gaff, who had made a fortune as the owner of a fleet of steamboats. Now credited to the architect Isaiah Rogers, the property survives without significant alterations.

The following architectural description has been written by Jeffrey Huntington, Curator of Hillforest:

The site is on a wooded slope, affording an outstanding view of the city of Aurora below and a broad sweep of the Ohio River Valley beyond.

The two story house with a basement has a five bay symmetrical front facade. Bay windows were added to the east and west first floor elevation to extend the length of the house and reinforce the symmetry...

The full-width frontal porch is reminiscent of the deck of a steamboat as is the circular second story of the morning room. To give detail and importance to the front entrance, the architect added the circular two story front which contains the vestibule and the morning room. To make this feature even more pronounced, wide vertical boards were used as opposed to the thin ship lap siding found throughout the rest of the house. The paired panelled round arched front doors are curved and the windows seem to be but are not. The sashes are curved, but the glass is straight. The door frame at the front entrance has a slight curve at the top to make the cast in more pronounced and to correct the perspective.

Throughout the house there are walk-through windows which allowed easy access to all porches and balconies. These windows replaced the need for a door at that location and allowed windows to be larger and more functional. An extra row of panes was added to the lower sash and when raised it slides up into the wall above. An interesting feature used in the windows are the round arches and the uses of paired windows. The railings on all the porches are cast in the Lyre pattern, a common 19th century design, and are made of cast iron.

On the corners of the house are quoins which were used to imitate stone and give the illusion from the street that the house might be stucco and stone, but in fact is built totally of cypress. The wide overhanging eaves are a common feature of the Italianate style as are brackets; however, the brackets of Hillforest are reminiscent of details from classical architecture called modillions which extend horizontally from the

THOMAS GAFF HOUSE (Hillforest)**Page 5**

United States Department of the Interior, National Park Service

National Register of Historic Places Registration Form

structure rather than the more common vertical brackets of the Italianate style. The roof structure is a low hip with ridge and there are decorative brick chimneys topped with earthenware chimney pots. Also, on the roof is the circular belvedere which in Italian means "Beautiful view". Webster's Dictionary says, "an elevated point of vantage affording an extensive view, especially, an upper story of An Italian building open on one or more sides so as to command a view,." This small structure has 16, paired, round arched windows, vertical siding, and a low pitched cone roof topped by a decorative finial.

The L-shape of the house is created by a rear service wing or Ell on the southeast corner. This portion of the structure differs from the rest because of its original height, which was lower than the main house, the smaller size of the window openings, and the slight step down of the porches which is evident between the dining room porch and the rear entrance porch. Also, the change from the fluted round porch columns with Acanthus leaves on the capitals to the simplified octagonal variation on the rear porch. The now third floor office was added in the 1870's or 1880's and extended the height of this rear wing by a 1/2 story above the main roof structure. Even though the detailing is the same, there are signs of the remodeling such as the vertical line in the siding on the east side and the one-over-one windows which are not located anywhere else in the house.

The sumptuous 12 room interior has a steamboat-like suspended stairway in the main hall with Honduran mahogany newel posts and fine parquet flooring. There are iron fireplaces in vintage design in the two front rooms. Eighteen-inch plaster borders decorate the main hall and parlors (made from molds imported from Italy). The 75-foot cross axis of the two parlors and hall is impressive. At the first stair landing the exterior door relates the home closely to the hillside gardens forming a villa-like effect with well planned services and formal approach. An Italian gardener laid out the large hillside estate, mountain villa style, with numerous rockeries, rustic paths, bridle trails, hillside terraces and vista areas.

The interior downstairs walls were hand decorated. The original Italian renaissance panels (trompe l'oeil) of the main hall have been restored (completed 1969). A second-hand art decoration was done in 1870 in a Pompeian style. The vestibule has been restored in this style. There are bedrooms upstairs and in the front of the second floor is a semicircular ladies morning room which overlooks the river, while overhead a stairway leads to Thomas Gaff's retreat: the belvedere.

THOMAS GAFF HOUSE (Hillforest)

United States Department of the Interior, National Park Service

Page 6

National Register of Historic Places Registration Form

Other than the addition by the Gaffs of a third room to the service wing at a later period, no basic changes have been made. Two restrooms were added from a portion of the butlers pantry by a subsequent owner.

GROUNDS

The grounds are an important part of Hillforest. The site was chosen to give prominence to the structure and is an integral part of the total design. The hillside site was integrated into the design of the house and the natural landscape influenced the development of the gardens. The front stone steps continue up from Main Street and are encompassed by the circular drive with stone gutters. The brick sidewalk along Fifth Street, originally called Literary Street, recalls an earlier time. The front entrance originally had iron gates.

The estate, which has about 10 acres, was large for the time and influenced by Italian landscaping. The movement in American architecture, led by A.J. Downing, which promoted large naturalistic landscapes is in evidence here. Before this time most town dwellers had no yards at all and little attention was paid to those who had them. Decorative lawns were seen as a way to embellish and accent architecture.

The hillside behind the house had formal gardens, a lake, gazebo, terraced gardens, and baths. The ravines of the landscape influenced the use of a rusticated foot bridge and the grotto. Above this on the hill were vegetable gardens, vineyards, orchards, and pasture land. Today, the farm and gardens are intact but very much overgrown.

The grotto was designed as part of the 1850's landscape design and was part of the water collection system for the grounds. Although designed in the rustic style, the grotto is man-made out of local stone built up to form a barrel vault. It is currently being restored.

Near the house is the melon cellar which was an accent to the landscape and was used as a seating area on top with its naturalistic table and benches. The glacial conglomerate rock used to construct this is thought to have been brought by boat from Split Rock, an island in the Ohio River.

The carriage house originally was much larger and more complex than the current 1970 reconstruction. The original building contained stalls, buggy storage, servants quarters, play room, possibly a summer kitchen, and had a drive-through over the driveway. The 3 hole-outhouse was attached to the rear of the building and a two-story greenhouse was to the front.

THOMAS GAFF HOUSE (Hillforest)

United States Department of the Interior, National Park Service

Page 7

National Register of Historic Places Registration Form

There is complex water system on the grounds which controlled run off and was a water supply to the house. There are possibly 11 cisterns on the property which store rain and spring water. Also, some water was directed from the eaves through second and first floor porch columns into a basement cistern. The storm sewer system consists of 3-foot square sewers made of rough hewn stone slabs. It is not known if the gardens were developed by imported Italian gardeners or if they were untrained laborers.¹

Hillforest today is beautifully maintained and is being carefully restored. The gardens are to be replanted and refurbished to their former glory and will be, when complete, one of the most important picturesque landscape complexes in the Mid-West.

Contributing Resources: Hillforest house
Grotto
Melon Cellar

Non Contributing: Carriage House

¹ Huntington, Jeffrey L. Report on the Architecture of Hillforest Foundation, Inc. Aurora, Indiana.

THOMAS GAFF HOUSE (Hillforest)

United States Department of the Interior, National Park Service

Page 8

National Register of Historic Places Registration Form

8. STATEMENT OF SIGNIFICANCE

Certifying official has considered the significance of this property in relation to other properties: Nationally: X Statewide: Locally:

Applicable National

Register Criteria: A B C X D Criteria Considerations
(Exceptions):A B C D E F G

NHL Criteria: #4

NHL Theme(s): XVI. Architecture

G. Renaissance Revival

1. Italian Villa

Areas of Significance: Architecture

Period(s) of Significance: 1853-1855

Significant Dates: N/A

Significant Person(s):

Cultural Affiliation: N/A

Architect/Builder: Isaiah Rogers, architect (1800-1869)

THOMAS GAFF HOUSE (Hillforest)

United States Department of the Interior, National Park Service

Page 9

National Register of Historic Places Registration Form

State Significance of Property, and Justify Criteria, Criteria Considerations, and Areas and Periods of Significance Noted Above.

Hillforest is an exceptional example of a wealthy family's estate on the bluffs above the Ohio river. The enterprising merchants and shippers of the river valley built homes that displayed their prosperity and patronage of the Arts, and the Gaff home is a remarkable remnant of that golden era in the 1850s. The house has recently been attributed to Isaiah Rogers (1800-1869), a leading American architect of the second quarter of the 19th century. Very few of his buildings survive, and Hillforest is the only remaining building of any type by Rogers that has undergone no significant alteration.

The recent attribution of Hillforest to Isaiah Rogers has been made by the authority on Rogers, Denys Peter Myers who discovered the architect's manuscript diaries. They are in the Avery Library. These personal notes give a fascinating picture of frontier life and the distances travelled to and from commissions along the waterways.

May 7, 1853 (Saturday) Cincinnati.

Started in steamer *Forest Queen*. Arrived down to Aurora at 4 o'clock. Went with Mr. Gaff and looked at his lot to make him a plan of a cottage. Paid passage 80 cents.

May 8, 1853 (Sunday) Aurora.

Stayed all night with Mr. Gaff. Well entertained. After breakfast took a walk with Mr. Gaff out on railroad. Picked some wild flowers. Returned and talked on various subjects and started at about 12½ o'clock. Arrived at Carrollton at 4½ o'clock. Mrs. Rogers and Isaiah (his younger son) on board. Had a very pleasant day. Some cool. Quite a good passage. Paid fare \$8.50.

May 11, 1853 (Wednesday) Frankfort.

Commenced to outline Mr. Gaff's house. Got plans outlined.

May 12, 1853 (Thursday) Frankfort.

Finished outlining elevations of Mr. Gaff's house.

May 13, 1853 (Friday) Frankfort.

Started on the *Diana* for Cincinnati. Had a very fine day, but cool. Left plans of Mr. Gaff's house with wharf boat keeper to give to Mr. Gaff.

THOMAS GAFF HOUSE (Hillforest)**Page 10**

United States Department of the Interior, National Park Service

National Register of Historic Places Registration Form

July 2, 1853 (Saturday) Aurora.

Called on Mr. Gaff and went with him and explained the parts of the plans not understood. Took breakfast with him and waited the first boat. Got the *Golden Gate* about 8½ o'clock. Arrived up to the city [Cincinnati] about 12½ o'clock.

November 30, 1853 (Wednesday) Cincinnati.

Wrote letter and sent bill to Mr. Gaff in Aurora.

May 13, 1854 (Saturday) Cincinnati.

Received from Mr. Gaff \$200, part pay for drawing plans.¹

Apparently Rogers did not supervise the building of Hillforest; he supplied the plans and over-all design.

The house is also similar to other work of Rogers in the 1850s. The cupola at Hillforest is similar to his Capital Hotel in Frankfort, Kentucky. Rogers had a strong interest in curvilinear forms in the late 1840s and early 1850s [examples are the George Hatch house in Cincinnati (1850) and a residence in Louisville where he maintained a branch office].

Isaiah Rogers was a leading American architect during the first half of the 19th century and was a prolific practitioner as well. He was born in Massachusetts, a sixth-generation descendant of John Rogers, who settled there in 1647. He was an apprentice housewright in 1817, and by 1821 he was in Mobile, Alabama to build a theater having won an architectural competition. In 1822 he joined Boston architect Solomon Willard, and became independent in 1826.

Rogers's first nationally important work was the Tremont House of 1828-1829 in Boston, which set a new standard for hotel design and is generally regarded as initiating American leadership in this field. It was unsurpassed for the dignity of its exterior and the convenience of its plan, the latter ingeniously masking the irregularity of the site. William H. Eliot's book, *A Description of Tremont House* (1830), spread Roger's fame among his contemporaries.... Rogers left for New York in 1834 to design the famous Astor House, an ever larger and more mechanically advanced hotel than Tremont House. While in New York he designed his masterpiece, the Merchant's Exchange (1836-1842), destroyed

¹ Isaiah Roger's manuscript diaries (1838-1856, 1861 and 1867) are in the Avery Architectural Library. Columbia University, New York. Unpagged.

THOMAS GAFF HOUSE (Hillforest)**Page 11**

United States Department of the Interior, National Park Service

National Register of Historic Places Registration Form

when four stories were added by McKim, Mead and White after 1907.²

Isaiah Rogers settled in Cincinnati, Ohio in 1848 and continued to build both private houses, hotels and public buildings. He also maintained an office in Louisville, Kentucky. He worked on the Ohio State Capitol (NHL) (1858-1861) and in 1862 was appointed chief of construction in the Treasury Department in Washington, DC, where he built the west wing of the United States Treasury (1862-1865). Returning to the midwest in 1865, Rogers continued to work and even held patents for bridge design and a "burglar proof safe."

The dearth of extant buildings by Rogers, since most of them have been mutilated or destroyed, makes Hillforest even more important. The Gaff house is the only remaining building by Rogers that has not been very much altered. Except for a minor addition of a rear room above the kitchen and the bathrooms, the house is pristine.

The Gaff family was typical of those pioneering settlers who lived in the mid-western river valleys and plied their trades along these commercial water ways. River shipping was the basis of Thomas Gaff's fortune which also was derived from distilleries, a brewery and a fleet of steamboats to transport his goods. He travelled beyond the Ohio River valley and owned Louisiana plantations that he could also visit by river boats.

Thomas Gaff was born in Edinburgh, Scotland, on July 8, 1808. His parents, James and Margaret Wilson Gaff, emigrated to America in 1811. The family lived for a while in New Jersey, upstate New York, and Brooklyn, New York, before moving on to Pennsylvania and finally to Indiana. James and Margaret had ten children; however only six lived until adulthood.

The brothers, Thomas, James, and John, took up storekeeping in Pennsylvania, added papermaking to their enterprises, then, in Philadelphia, distilling. They were successful and made money.

The Panic of 1837 dampened the national economy and taxes on liquor went up. The Gaff brothers began having trouble getting the grain on which their distillery depended.

The Gaffs were offered tax incentives and land to move their business to Aurora. James came about 1840 while Thomas stayed in the East to close their affairs there and came about 1843. Soon after John followed. By the

² Macmillan Encyclopedia of Architects. Edited by Adolph K. Placzek. Collier-Macmillan. New York, 1982, Volume 3. pp. 599-601.

THOMAS GAFF HOUSE (Hillforest)**Page 12**

United States Department of the Interior, National Park Service

National Register of Historic Places Registration Form

1840's their father, James, had died and their widowed mother and three sisters came to Aurora.

Once in Aurora, the Gaffs took up storekeeping and shipping in a building at the corner of Second and Judiciary Streets. Thomas Gaff married the widow Sarah Darling Whipple (1804-1891) in Brooklyn, N.Y., in 1835. They had six children, but only three survived childhood. At the beginning, the entire family lived above the store in very cramped quarters. Thomas, his wife Sarah, and their children, as well as Thomas's mother Margaret lived there until Hillforest was completed in 1855. In 1843, they built a distillery on the banks of nearby Hogan Creek. Eventually this distillery produced bourbon, rye, and scotch (Thistle Dew scotch), and was by mid-century one of the largest in the country.

Next came a brewery, the Crescent Brewing Company, at the front of Market Street, a few blocks from Hillforest. It featured Aurora Lager Beer, which was exported to Germany. The remains of the great stone cellars where the beer was kept cool may be seen today from Aurora's riverfront park.

The Gaffs took up farming as an adjunct to buying grain for distilling, and also engaged in milling. Their mill at Columbus, Indiana, turned out "Cerealine", which makes a disputed claim to being the first ready-made cereal in the world. In hog-lots along Hogan Creek, just one block north of downtown Aurora, the Gaff brothers raised hogs for market and fattened them with mash, a byproduct of their distillery.

The economic ventures of the family were diverse, including silver mines in Nevada, turnpike construction, and railroad financing. Thomas was one of the original stockholders of the Ohio and Mississippi Railroad (later known as the Baltimore and Ohio or B & O Railroad), which located its maintenance shops and yard in the town of Cochran, today part of Aurora.

The Gaffs were among the backers of Aurora's first utility company, the Aurora Gas and Coke Company, which started supplying gas for lighting about 1875. They were among the founders of the First National Bank, which began in 1856, and Thomas was its first president. The first telephone in Aurora came to the Gaff distillery in 1869 and connected them to the Henry Winthrop Smith Co. in Cincinnati.

Thomas was one of the incorporators of Riverview Cemetery, but the Gaff family was buried at Cincinnati's Spring Grove Cemetery. He also interested

THOMAS GAFF HOUSE (Hillforest)**Page 13**

United States Department of the Interior, National Park Service

National Register of Historic Places Registration Form

himself in the establishment of graded schools and served on the school board.

There was also a partnership of the Gaffs and Julius Fleischman, who came to America from Vienna to make yeast by a new process. In the early years the company was known as Gaff, Fleischman & Co. The venture looked like a failure until, as a last gamble, a pastry shop and restaurant were set up at the 1876 Philadelphia Centennial Exposition, and Fleischman's yeast was used in the baking there. The Fleischmans became very successful and are still in business today.

The Gaffs owned and apparently built a number of steamboats, among them *Diana*, *Mary Pell*, *Eclipse*, *J.W. Gaff*, and *Forest Queen*. *Forest Queen* served for a time as General William Tecumseh Sherman's headquarters at Vicksburg, and later successfully ran the blockade there during the Civil War battle.³

Hillforest remained in the Gaff family until 1926 when it passed to the Stark family. Today it is maintained and preserved by the Hillforest Historical Foundation, Inc., founded in 1956 and open to the public as a house museum.

³ Baker, Dodie. "Report on the Gaff Family Geneology 1990." Hillforest Historical Foundation, Inc. Aurora, Indiana.

THOMAS GAFF HOUSE (Hillforest)**Page 14**

United States Department of the Interior, National Park Service

National Register of Historic Places Registration Form

9. MAJOR BIBLIOGRAPHICAL REFERENCES

Bibliography

American Biographical History of Eminent and Self-Made Men of the State of Indiana. 1880.

Antiques: Fads in American Architecture. May 1955.

American Quarterly. Transportation Design Elements in American Architecture. October 1956. pp. 203-204.

History of Dearborn & Ohio Counties, Published 1885-F.E. Weakley & Company-Biographical Sketch pp 717-18; Industries - Aurora Distilling Corporation- pp. 339-41, The Crescent Brewing Company pp 345-6 and First National Bank p. 351.

Historical Files Indiana University - Bloomington, Indiana.
A file of paper referring to Gaff Steamboats and to two southern plantations.

Indiana History Bulletin, November 1962 pp 158-159.

Isaiah Roger's manuscript diaries (1838-1856, 1861, and 1867) are in the Avery Architectural Library, Columbia University, New York.

Biographical Encyclopedia of Ohio of the Nineteenth Century, 1876 Cincinnati; Galaxy

Drummond, Josiah H. 1898 *John Rogers of Marshfield and Some of His Descendants*. Portland, Me.: Smith & Sale.

Hamlin, Talbot (1944) 1964 *Greek Revival Architecture in America*. Reprint New York: Dover.

Hitchcock, H. R. (1963) 1977 *Architecture: Nineteenth and Twentieth Centuries*. Baltimore: Penguin.

Macmillan Encyclopedia of Architects Edited by Adolf K. Placzek. Collier Macmillan-4 vols 1982 New York

Myers, Denys Peter 1951 "Isaiah Rogers in Cincinnati." Bulletin of the Historical and Philosophical Society of Ohio 9: 121-132.

Myers, Denys Peter 1966 "The Recently Discovered Diaries of Isaiah Rogers." Columbia Library Columns 16;25-31.

Peat, Wilbur. David. *Indiana Houses of the Nineteenth Century* Indiana Historical Society 1962. Indianapolis.

THOMAS GAFF HOUSE (Hillforest)

United States Department of the Interior, National Park Service

National Register of Historic Places Registration Form

Previous documentation on file (NPS):

- Preliminary Determination of Individual Listing (36 CFR 67) has been requested.
- Previously Listed in the National Register.
- Previously Determined Eligible by the National Register.
- Designated a National Historic Landmark.
- Recorded by Historic American Buildings Survey: # _____
- Recorded by Historic American Engineering Record: # _____

Primary Location of Additional Data:

- State Historic Preservation Office
- Other State Agency
- Federal Agency
- Local Government
- University
- Other: Specify Repository: _____

THOMAS GAFF HOUSE (Hillforest)**Page 16**

United States Department of the Interior, National Park Service

National Register of Historic Places Registration Form

10. GEOGRAPHICAL DATA

Acreage of Property: 11 acres

UTM References: Zone Easting Northing

A 16 681610 4324700

Verbal Boundary Description:

Hillforest Historical Foundation, Inc., in Dearborn County, State of Indiana.

In Lots Numbers Two Hundred Seventeen (217), Two Hundred Eighteen (218), Two Hundred Nineteen (219) and Two Hundred Twenty (220) as marked and designated on the original Plat or Plan of the Town (now City) of Aurora, said County and State: as per "Plat of Aurora" Plat book 4, p. 1.

ALSO: All that part of Main Street as marked on the original Plat Of said town (now city) lying south of Fifth or Library Street in said city having been heretofore vacated by the Common Council of the City of Aurora in the year 1875:

ALSO: Out Lots Numbers Twenty-seven (27) and Fifty-seven (57) and parts of Out Lots Forty-one (41) and Forty-two (42) in said City of Aurora, as shown on the recorded Plat or Plan of said City, bounded and described as one tract, as follows: Beginning at the Northeast corner of said Out Lot Number 57, which point is North 70° West 33 feet from the Northwest corner of Out Lot Number 39; thence North 70° West 339.5 feet to the Northwest corner of said Out Lot Number 27; thence South 20° West 877 feet to the South line of said Out Lot Number 41; thence South 70° east 340 feet to the Southeast corner of Out Lot No. 41 thence North 20° East 876.5 feet to the place of beginning; containing 6.90 acres of ground, more or less:

ALSO: All of the right, title and interest of grantor herein, if any there be, in and to any part of Out Lots Number 28 and 42 in said city of Aurora, constituting any part of what is known as the former "Gaff Homestead"; being the same premises heretofore conveyed unto Grantor herein by Emery Nocks Post No. 5312- V.F.W. by Deed dated January 18th, 1956, and recorded in Deed Record No. 114, page 338, of the Records of Dearborn County, Indiana.

Boundary Justification:

The acreage is historically the Gaff Family estate, including the house and gardens.

THOMAS GAFF HOUSE (Hillforest)**Page 17**

United States Department of the Interior, National Park Service

National Register of Historic Places Registration Form

11. FORM PREPARED BY

Name/Title: Carolyn Pitts
Org.: History Division, National Park Service
Street/#: P.O. Box 37127
City or Town: Washington
State: DC
ZIP: 20013-7127
Telephone: (202) 343-8166
Date: April 8, 1992

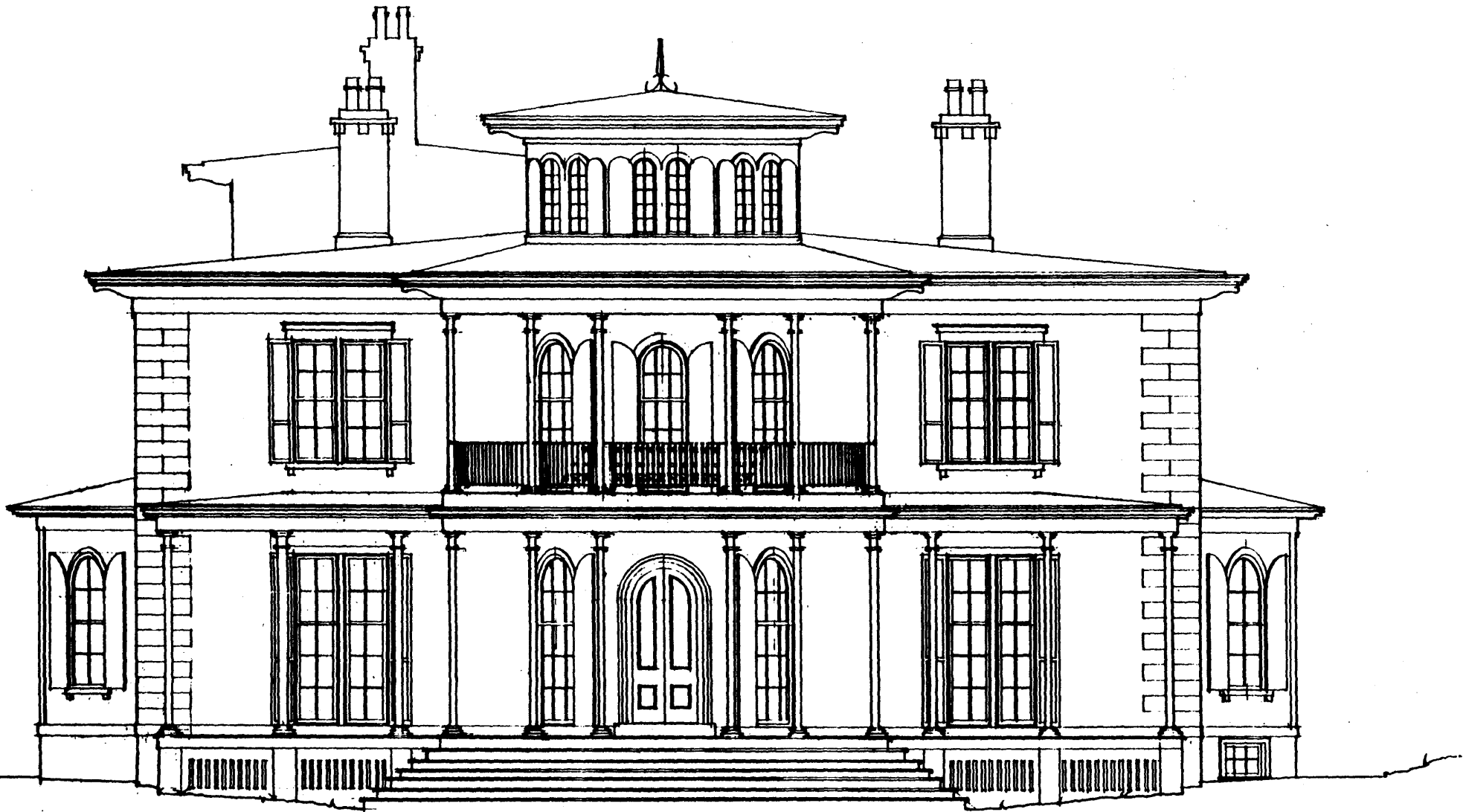

NORTH ELEVATION

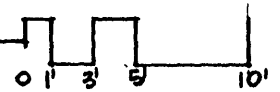



WEST ELEVATION

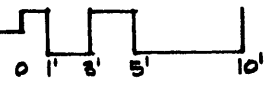



EAST ELEVATION





SOUTH ELEVATION

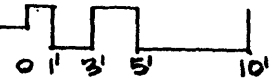

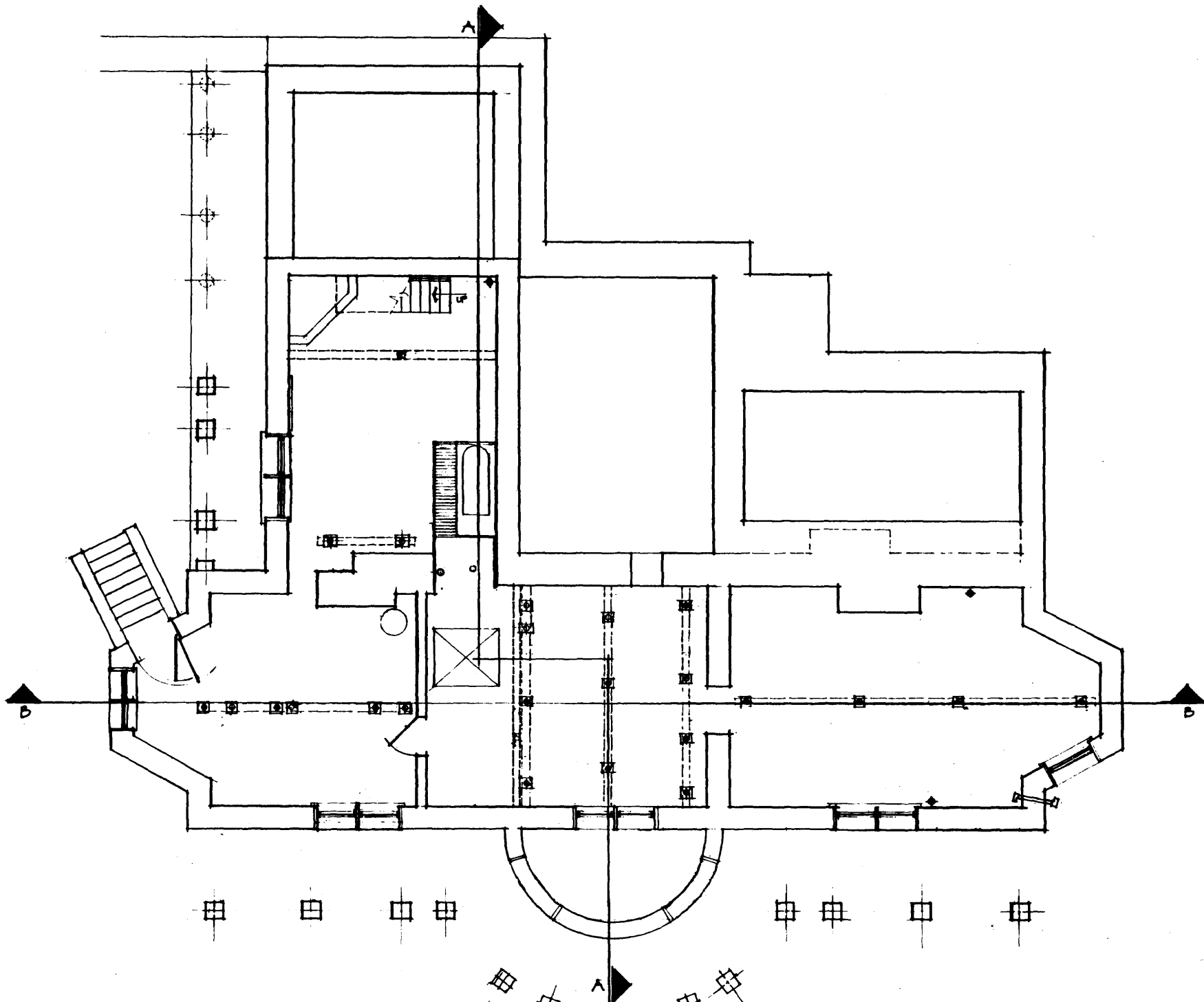

⊗ BASEMENT / FOUNDATION PLAN



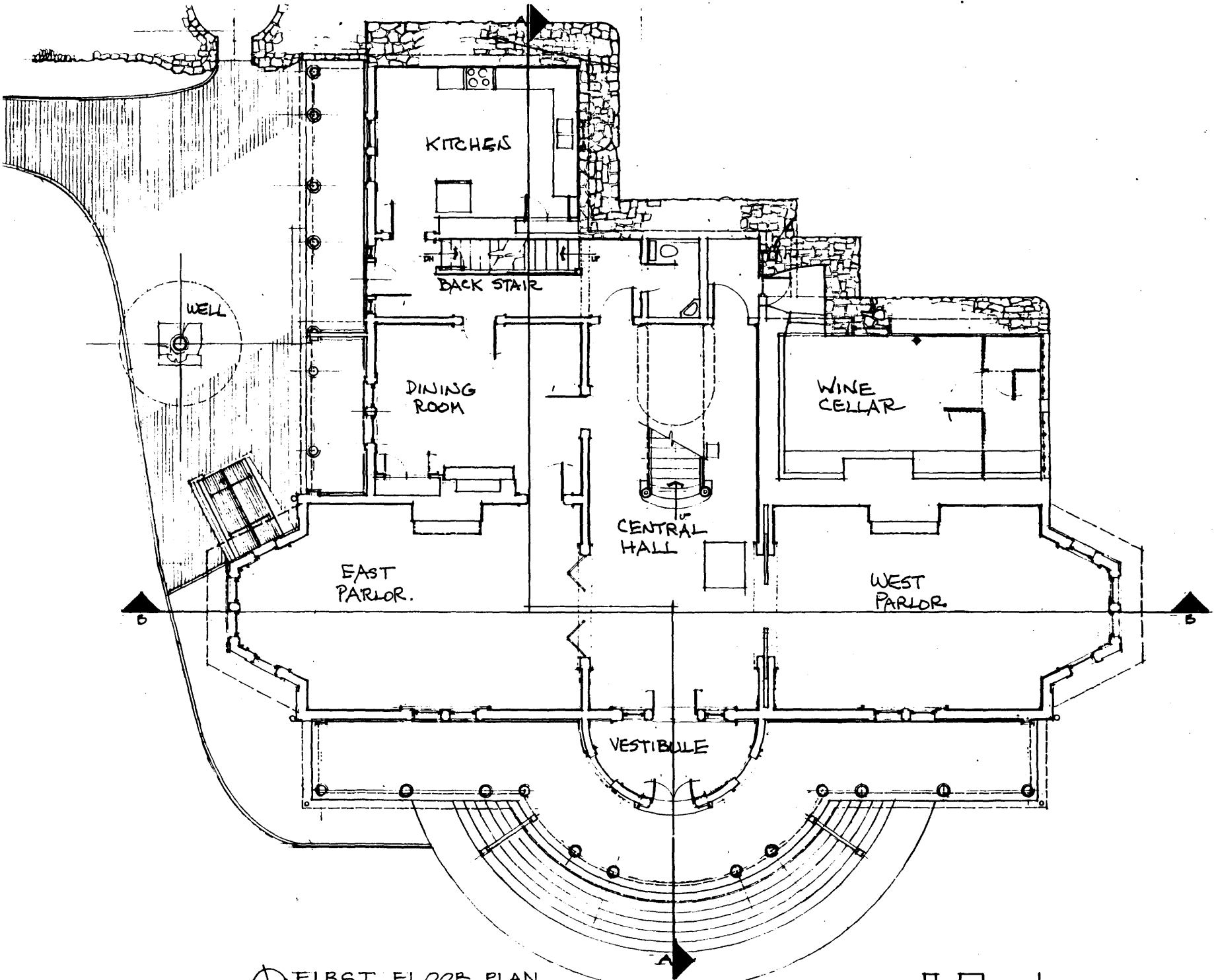

FIRST FLOOR PLAN

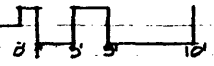

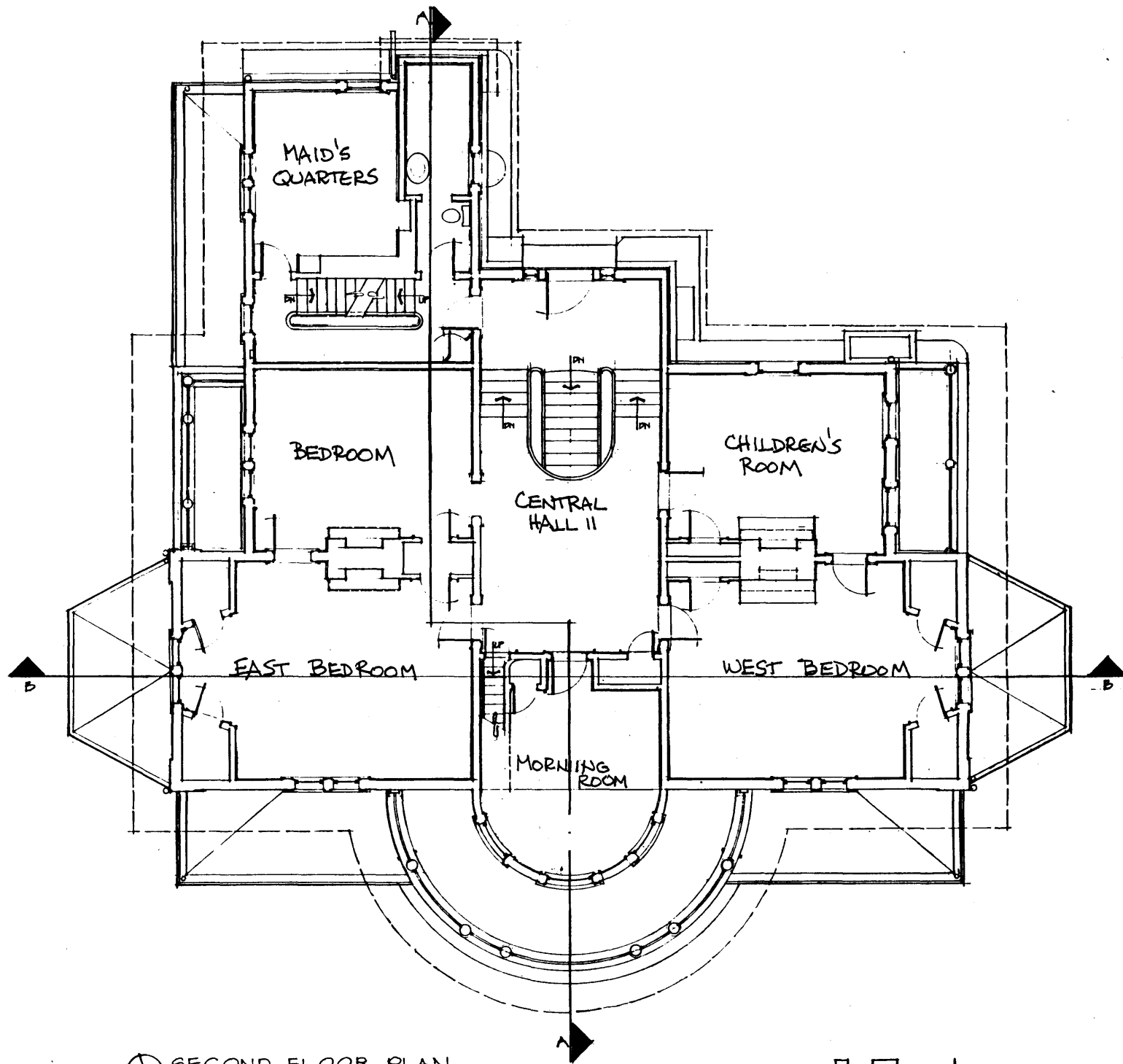

⊕ SECOND FLOOR PLAN

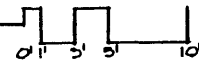

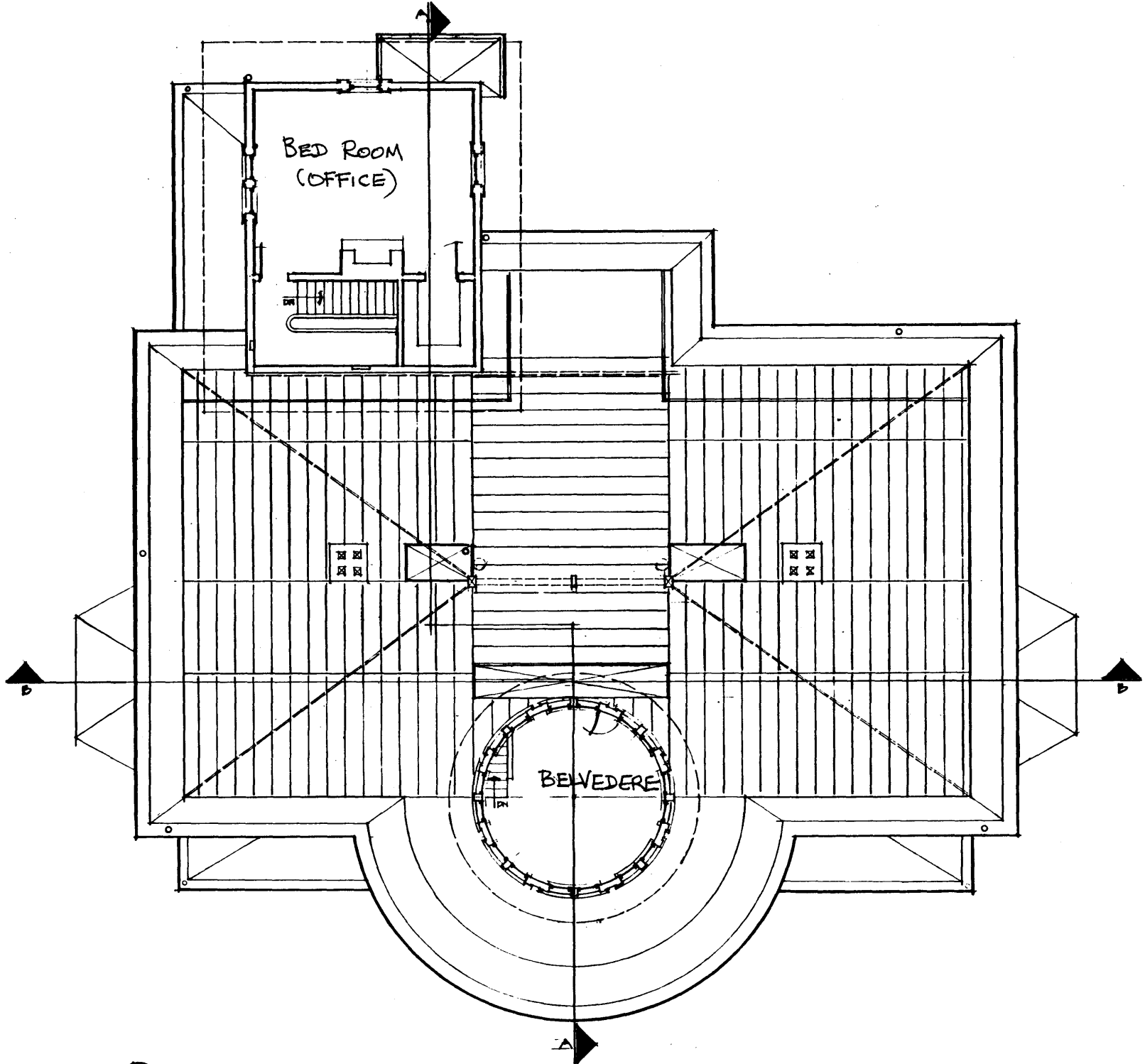

⊙ THIRD FLOOR/ATTIC PLAN

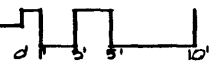

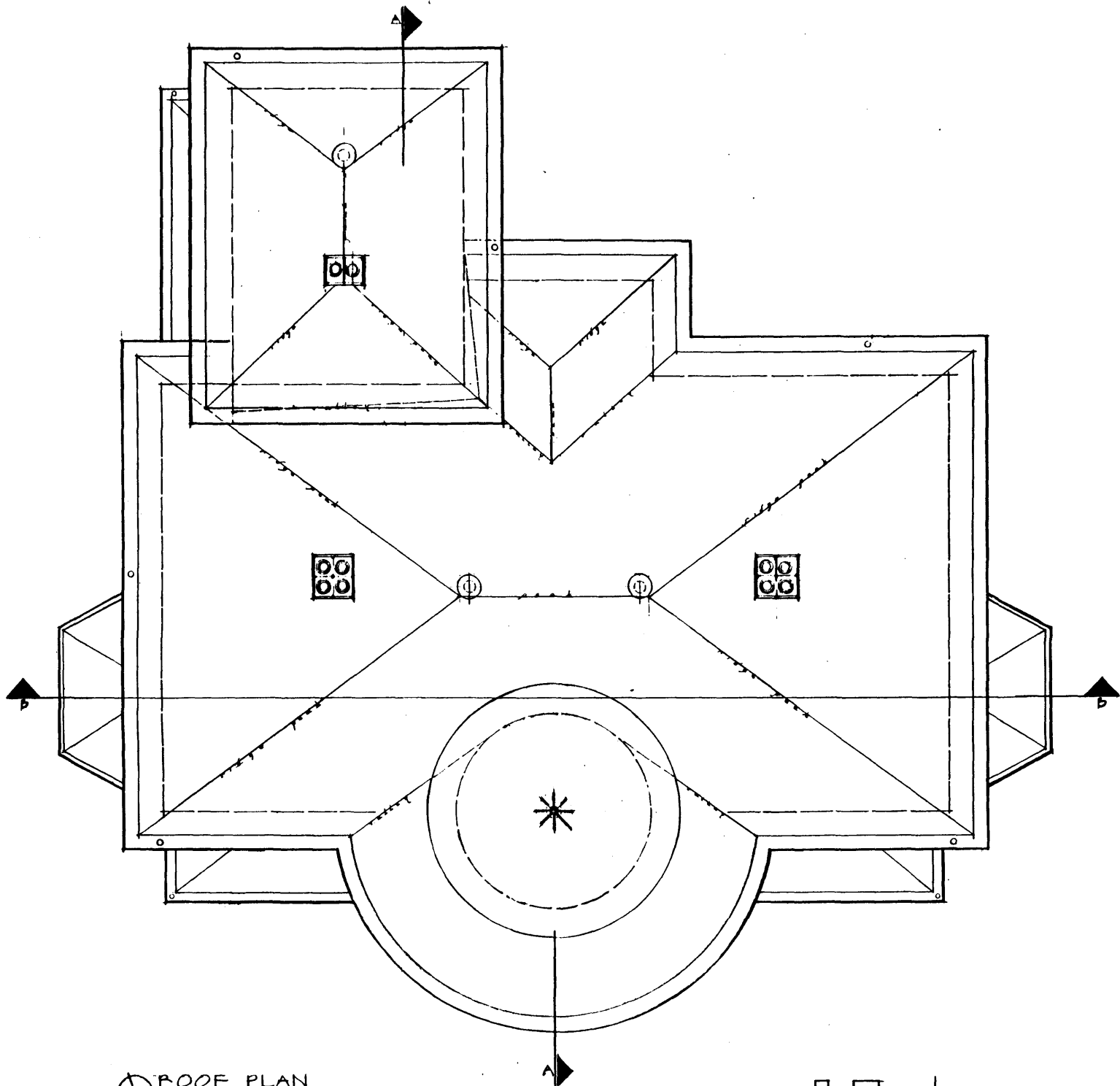

ROOF PLAN

