

**United States Department of the Interior
Heritage Conservation and Recreation Service**

**National Register of Historic Places
Inventory—Nomination Form**

See instructions in *How to Complete National Register Forms*
Type all entries—complete applicable sections

1. Name Ward-Force House and Condit Family Cook House

historic Theophilus Ward/Thomas Force House & Condit Family Cook House

and/or common Force Home or Old Force Homestead

2. Location

street & number 366 South Livingston Avenue not for publication

city, town Livingston vicinity of congressional district 5th

state New Jersey code 34 county Essex code 013

3. Classification

Category	Ownership	Status	Present Use	
<input type="checkbox"/> district	<input checked="" type="checkbox"/> public	<input checked="" type="checkbox"/> occupied	<input type="checkbox"/> agriculture	<input checked="" type="checkbox"/> museum
<input checked="" type="checkbox"/> building(s)	<input type="checkbox"/> private	<input type="checkbox"/> unoccupied	<input type="checkbox"/> commercial	<input type="checkbox"/> park
<input type="checkbox"/> structure	<input type="checkbox"/> both	<input type="checkbox"/> work in progress	<input type="checkbox"/> educational	<input type="checkbox"/> private residence
<input type="checkbox"/> site	Public Acquisition	Accessible	<input type="checkbox"/> entertainment	<input type="checkbox"/> religious
<input type="checkbox"/> object	<input type="checkbox"/> in process	<input checked="" type="checkbox"/> yes: restricted	<input type="checkbox"/> government	<input type="checkbox"/> scientific
	<input type="checkbox"/> being considered	<input type="checkbox"/> yes: unrestricted	<input type="checkbox"/> industrial	<input type="checkbox"/> transportation
		<input type="checkbox"/> no	<input type="checkbox"/> military	<input type="checkbox"/> other:

4. Owner of Property

name Township of Livingston

street & number 357 South Livingston Avenue

city, town Livingston vicinity of state New Jersey

5. Location of Legal Description

courthouse, registry of deeds, etc. Register of Deeds and Mortgages, Hall of Records

street & number 469 High Street

city, town Newark state New Jersey

6. Representation in Existing Surveys

title N.J. Historic Sites Inventory has this property been determined eligible? yes no

date 1960 federal state county local

depository for survey records Cultural and Environmental Services

city, town Trenton state New Jersey

7. Description

Condition		Check one	Check one
<input type="checkbox"/> excellent	<input type="checkbox"/> deteriorated	<input type="checkbox"/> unaltered	<input type="checkbox"/> original site
<input checked="" type="checkbox"/> good	<input type="checkbox"/> ruins	<input checked="" type="checkbox"/> altered	<input type="checkbox"/> moved date _____
<input type="checkbox"/> fair	<input type="checkbox"/> unexposed		

Describe the present and original (if known) physical appearance

The Thomas Force House is a wood frame building, consisting of three basic sections - a 1 1/2 story center portion built around 1745, a large early 19th century 2 1/2 story gambrel roofed unit, and a 1 1/2 story 1927 garage addition on the west that also extended the width of the original 18th century section and raised its eastern roof plane. The Condit Family Cook House, a small 19th century 1 1/2 story wood frame building with two small rooms, was moved onto the northwest corner of the property in 1964.

The Thomas Force House (located at 366 South Livingston Avenue) is owned by the Township of Livingston, N.J. and presently a museum and headquarters for the Livingston Historical Society. The oldest portion of the Force House (now the present center section of the building) was built in 1745 by Theopolius Ward. The original one and one-half story dwelling (see floor plans) on a stone foundation was constructed of a wood timber frame, covered with clapboard siding, and had a high pitched gable roof with wood shingles. The house consisted of one large main room with a fireplace and stone chimney in the northwest elevation wall and a second story loft. The extension of the lower portion of the rear roof formed a porch area that was enclosed at a later date to form the present lower kitchen area. The original house was a part of the Ward Farm, which according to documents advertising the property for sale in 1762 and 1768 consisted of 225 acres of land partially cleared and fenced for meadows, apple and peach trees, and a nursery, with the remainder of the land in timber or swamp. The advertisement also noted the presence of a stream and saw mill on the property.

This mid 18th century section is a nearly square 18' x 20', 1 1/2 story, 3 bay, gable roofed dwelling with a side entrance. The dormer which breaks the south plane of the roof was added in 1951. There is a single room on the first floor and the loft above. The exposed hand hewn beams are five inches by eight inches. There is a large stone fireplace with Dutch oven in the west end wall. A small winding stair is tucked into the southwest corner against the fireplace.

A large two and one-half story section projecting toward the roadway was added to the southeast elevation wall of the original house by Thomas Force during the early part of the 1800's. This section of the house was built of wood frame siding with two chimneys on the east gable end, and a gambrel roof with wood shingles and overhanging eaves. This section has a 3 bay, through side hall plan. Windows are 6/6 sash with paneled shutters on the first floor and louvered shutters on the second floor. The windows are shown as 9/6 sash in the 1939 HABS drawings.

8. Significance

Period	Areas of Significance—Check and justify below			
<input type="checkbox"/> prehistoric	<input type="checkbox"/> archeology-prehistoric	<input type="checkbox"/> community planning	<input type="checkbox"/> landscape architecture	<input type="checkbox"/> religion
<input type="checkbox"/> 1400-1499	<input type="checkbox"/> archeology-historic	<input type="checkbox"/> conservation	<input type="checkbox"/> law	<input type="checkbox"/> science
<input type="checkbox"/> 1500-1599	<input checked="" type="checkbox"/> agriculture	<input type="checkbox"/> economics	<input type="checkbox"/> literature	<input type="checkbox"/> sculpture
<input type="checkbox"/> 1600-1699	<input checked="" type="checkbox"/> architecture	<input type="checkbox"/> education	<input type="checkbox"/> military	<input type="checkbox"/> social/ humanitarian
<input checked="" type="checkbox"/> 1700-1799	<input type="checkbox"/> art	<input type="checkbox"/> engineering	<input type="checkbox"/> music	<input type="checkbox"/> theater
<input checked="" type="checkbox"/> 1800-1899	<input type="checkbox"/> commerce	<input type="checkbox"/> exploration/settlement	<input type="checkbox"/> philosophy	<input type="checkbox"/> transportation
<input type="checkbox"/> 1900-	<input type="checkbox"/> communications	<input type="checkbox"/> industry	<input type="checkbox"/> politics/government	<input type="checkbox"/> other (specify)
		<input type="checkbox"/> invention		

Specific dates 1745

Builder/Architect

Theophilus Ward

Statement of Significance (in one paragraph)

The Theophilus Ward/Thomas Force House, built around 1745 and expanded significantly in the early 19th century, is one of the few early farmhouses in the Township of Livingston which has retained much of its original character, craftsmanship and details. The well preserved farmhouse and the surrounding park evoke a clear picture of 18th-19th century rural Essex County.

The frame 1 1/2 story mid-18th century dwelling - its single room first floor and loft with the gable end wall containing a large cooking fireplace next to a corner winding stair - is a typical 18th century New Jersey plan, but an uncommon survivor for Essex County. The 2 1/2 story gambrel roofed addition was built by Thomas Force and is representative of rural domestic Federal architecture of northern New Jersey in the early 19th century. Its construction laterally adjacent to the earlier dwelling was a common building pattern in the state.

It was Samuel Force of Woodbridge who bought property in Canoe Brook (Livingston Township) for his sons Thomas and Jonathan. The land, house, and sawmill he bought for Thomas were on the road that is now South Livingston Avenue. The sawmill is gone, its only evidence being some rock construction in Canoe Brook near the Livingston Town Hall. The property was advertised for sale in 1761 and 1762 in colonial newspapers. Purchasers were advised to contact Theophilus Ward living in the house or Samuel Ward of Staten Island. It is uncertain when Samuel Force bought the house, but Samuel's will in 1794 mentions his purchase of property in Canoe Brook as gifts to his sons Thomas and Jonathan. (New York Genealogical and Biographical Quarterly Magazine. 1954, p. 160.)

Thomas Force was an early settler in the area, a veteran of the American Revolution, active in local affairs, and one of the original Township officials. He was born in Woodbridge, New Jersey in 1758. Thomas Force served in the Revolutionary War as a Corporal in Captain Henry Squire's Company, the Second New Jersey Regiment, Essex County Troops; was a prisoner on the British prison ship Jersey, and was present at the winter encampment of American Troops at Valley Forge between 1777 and 1778. He married Hannah Smith around 1780-82 and was probably given this farmstead at that time.

In addition to operating his farm and sawmill, Thomas Force was associated with the local and religious affairs of the Canoe Brook area during his lifetime. In 1782, along with other early settlers, he helped erect the first school house in the area, a crude stone building at

9. Major Bibliographical References

See Continuation Sheets

10. Geographical Data

Acreage of nominated property .5437

Quadrangle name Caldwell, NJ

Quadrangle scale 1:24,000

UMT References

A 18 557660 4514530
 Zone Easting Northing

B
 Zone Easting Northing

C

D

E

F

G

H

Verbal boundary description and justification

See Continuation Sheet

List all states and counties for properties overlapping state or county boundaries

state code county code

state code county code

11. Form Prepared By

Revisions by Terry Karschner, Office of Cultural and Environmental Services 8/1981

name/title Russell A. Jones, Jr., Assistant to the Manager

organization Township of Livingston date 2/27/1981

street & number 357 South Livingston Avenue telephone (201) 992-5000

city or town Livingston state New Jersey 07039

12. State Historic Preservation Officer Certification

The evaluated significance of this property within the state is:

 national state X local

As the designated State Historic Preservation Officer for the National Historic Preservation Act of 1966 (Public Law 89-665), I hereby nominate this property for inclusion in the National Register and certify that it has been evaluated according to the criteria and procedures set forth by the Heritage Conservation and Recreation Service.

Deputy

State Historic Preservation Officer signature

title Lawrence Schmidt

DSPPO date November 12, 1981

For HCRC use only

I hereby certify that this property is included in the National Register Entered in the National Register

for fact
Melvin Byers
 Keeper of the National Register

date 12/29/81

Attest:

date

Chief of Registration

**United States Department of the Interior
Heritage Conservation and Recreation Service**

**National Register of Historic Places
Inventory—Nomination Form**

Ward/Force House, Livingston, Essex County, NJ
Condit: Cook House

Continuation sheet

Item number 7

Page 1

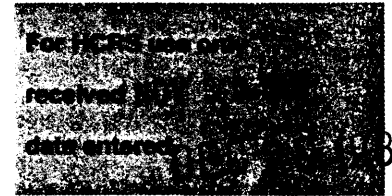

7. DESCRIPTION (Continued)

The main entrance appears to be a mid-19th century modification of what was probably a simple narrower opening. The present wide entrance has rectangular sidelights and transom surrounding a four panel door with rounded arch upper panels. Portrayed in the HABS drawings is a late 19th century one story wooden porch on the southwest, southeast and northeast*

The interior of this section contains a cellar area, two rooms and a hallway on the first floor, three rooms and a hallway on the second floor, and a large exhibit area on the third floor, later partitioned into a hallway and two rooms.

The hall is nearly 10 feet wide featuring a paneled stair with a graceful balustrade and railing against the northwest corner. East of the hall are two identical rooms (13' x 15') with end wall fireplaces. The second floor repeats the plan. Moldings and doors throughout have typical late 18th - early 19th century details. Particularly noteworthy is the curved shelf mantelpiece with sunburst motif and fluted pilaster in the dining room. The other mantelpieces are quite simple.

The third section of the house, a one and one-half story addition with a high pitched gable roof, was added into the northwest elevation wall of the original portion of the house in 1927 by George B. Tuttle. This wood frame addition, built on a concrete slab foundation, contained a garage area (present barn exhibit area), a narrow room or hallway (present buttery room) extending from the northeast elevation exterior wall to an interior southwest elevation wall and separating the garage area from the original main room and lower kitchen. A doorway at the end of this room leads to another similar narrow room (present storage room) possibly added at this time and is located parallel to the interior southwest elevation wall of the garage.

The interior finish in the two smaller rooms consists of a concrete floor and sheetrock walls and ceiling in the store room, and wide wood flooring boards and plaster walls and ceiling in the buttery. The former garage area has been converted to a display area, resembling the interior of a barn, for the purpose of exhibiting tools and farm implements. The interior of this room has wide wood board floor installed over the concrete floor, and horizontally applied wide wood shiplap boards on the walls. A loft area was created by laying wide boards across a portion of the garage ceiling beams. A window in the northwest exterior wall elevation and a doorway to the storeroom in an interior southwest wall

*elevations of the main house. This bracketed porch was removed between 1940 and 1960.

United States Department of the Interior
Heritage Conservation and Recreation Service
National Register of Historic Places
Inventory—Nomination Form

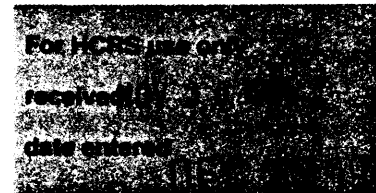

Continuation sheet

Item number 7

Page 2

7. DESCRIPTION (Continued)

were closed off with the wood paneling. During this time, the two overhead garage doors were removed and their openings replaced with a smaller doorway containing a pair of barn style doors. The exterior of this section of the house is wood shingled, as is the rest of the house.

Major changes to the Ward/Force House since 1950 include a masonry exterior front entrance stair, substantial modification to the lower kitchen in the 18th century unit (fireplace and hearth built; partitions, doors and cabinets removed) and display room completed on the attic floor of the gambrel roofed unit.

The Condit Family Cook House. Moved onto this site in 1964, the building is a 12' 3" x 18' 3-3/4" wood frame structure with fireplace, one and one-half stories in height, and containing two rooms. At its original location the Condit Family Cook House was used as a summer kitchen, later as a tenant house, wash house, and store room.

The exact date the Cook House was built is not known - the type of use and materials used in the construction indicate that the building was constructed some time during the later part of the 1700's. This building was originally a part of a large farm of several hundred acres, that was located at the intersection of Walnut Street and South Orange Avenue in the Cheapside section of the Township, and known for many years as the Ira Condit Farm. On this original site, the Cook House was located southward of the main farmhouse at No. 370 Walnut Street, which stood on a knoll facing the intersection of South Orange Avenue and Walnut Street (before its relocation). The site also contained a main farmhouse, several barns and other farm buildings. It is now the location of the Livingston Shopping Mall.

The Cook House is a one and one-half story building constructed with a wood timber frame covered with clapboard siding, a gable roof with wood shingles, and was originally located on a stone foundation which formed a crawl space area beneath the first floor level and contained an outside access door. Most of the original clapboards are still present on the house, with the exception of two small areas on the northeast and southwest elevation walls which have been repaired. The front or northeast elevation wall has two window units and an entrance doorway to the first floor, which contains one room with a fireplace and enclosed stairway. The interior southeast elevation wall is completely bricked, contains a large fireplace with crane and baking oven, and a brick hearth laid in a herringbone pattern. This fireplace was dismantled and rebuilt when the house was moved. Other interior details

United States Department of the Interior
Heritage Conservation and Recreation Service
National Register of Historic Places
Inventory—Nomination Form

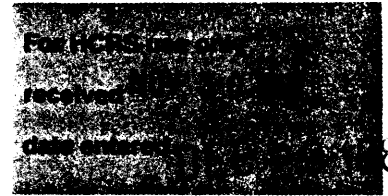

Continuation sheet

Item number 7

Page 3

7. DESCRIPTION (Continued)

include random width wood flooring boards laid, lath and plaster walls and ceiling, a simple wood base molding, and two window units of unequal size located in the rear wall. Located in the northwest corner is an enclosed stairway to the second story loft area. The stairway is enclosed with vertically applied wood panelling, and contains a small storage closet area with door underneath.

The second floor of the building contains an unfinished loft area that was used for sleeping purposes. The open wall cavities in this area show the type of frame construction that was used in the building. Large vertical timbers are located in each corner, and in the center of the front and rear walls, extending upward approximately 22 inches above the random width flooring boards of the second level. In each of the front and rear walls, these timbers support a horizontal hand-hewn beam, secured by mortise and tenon joints with wood pegs. To the underside of both roof support beams are attached two corner braces that extend diagonally downward toward the outer side walls of the first floor. Rough shaped wood studding comprise the framing of the southeast and northwest elevation walls (gable ends) and between the main timbers in the northeast and southwest elevation walls. The roof is formed by eight pairs of rafters, uniformly spaced, notched at the bases, attached to the horizontal wall beam and held together at the ridge line by overlapping joints and wood pegs. The underside of the roof consists of wood lath to which are applied courses of wood shingles and presently serve as a base for the later roof covering of asphalt shingles. A brick chimney extends upward from the first floor fireplace and through the ridge line of the roof at the gable end of the southeast elevation wall. The two end walls contain a three pane window.

United States Department of the Interior
Heritage Conservation and Recreation Service
National Register of Historic Places
Inventory—Nomination Form



Continuation sheet

Item number 8

Page 1

8. SIGNIFICANCE (Continued)

Northfield Center. In 1786, Thomas was one of the original members who formed the Canoe Brook Baptist Society. One of the earliest meetings of this society was held in the Force home during the same year. Thomas was a member of this church for forty-one years and a Deacon for almost forty years, carrying on the society's work. In 1800, when the Baptist Society incorporated as the Northfield Baptist Church, Deacon Thomas Force gave woodland timbers and sawed some of the lumber for the construction of the first church building at Northfield Center. He also served as an Overseer of Highway in 1787 and 1790, according to records of the Township of Newark. Thomas Force built the 2 1/2 story frame addition around this time.

When the state legislature granted a charter for the formation of the Township of Livingston in 1813, Thomas Force was chosen as one of the original town officers, again serving as an Overseer of the Highway. Thomas Force died in 1827 and is buried in the Northfield Baptist Cemetery. (Newark Sentinel of Freedom. April 10, 1827. Obituary)

Thomas Force by his will dated 10 April 1827 directed his executor, William B. Force, to sell "the land deeded to me by my father" if necessary to cover the debts and legacies. Accordingly, twelve years later, the executor and his wife Martha Ann of Livingston Township, Essex County, conveyed by deed to John Emmons of New York City, for \$5000 the three tracts "with all and singular the houses, buildings".

John Emmons apparently resided in this farmhouse at the time of his death in 1868. He devised his estate to his wife Eliza Ann Emmons for her lifetime, and thereafter to his sons, William and George. By a deed of 10 April 1872, George Emmons and wife Betsey and William Emmons, all of Livingston Township, conveyed to Carl Hinderer of Newark, in same county, for \$11,500, the two tracts, 60 and 5 acres, first described above, and a third tract they had purchased by Deed of 19 March 1872, being 30.33 acres. As a result of proceedings in foreclosure of the mortgage given by Hinderer, the property was seized by the sheriff and conveyed back to the Emmons brothers by deed of 20 January 1874.

One of them, William Emmons, with wife Cecelia, then conveyed to the other, George Emmons, his undivided half of the three tracts by deed of 19 May 1884, and he with wife Adella, conveyed to Frank C. O'Reilly the same 98 acres of deed of 22 July 1885. Ralph O'Reilly, then of Paris, France, conveyed 54 acres thereof to Helen S. Kroeger by deed of 11 March 1925, and she sold it to Herbert Austin by deed of 30 April 1925. Austin laid out the property in building lots, and conveyed nos.

**United States Department of the Interior
Heritage Conservation and Recreation Service**

**National Register of Historic Places
Inventory—Nomination Form**

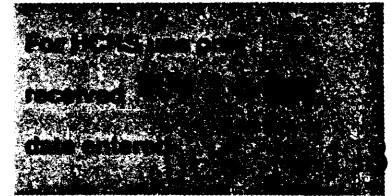

Continuation sheet

Item number 8

Page 2

8. SIGNIFICANCE (Continued)

17-18-19-20 to Hermine B. Tuttle in 1927. The property was seized by sheriff and conveyed to Lawrence Greggio in 1935 from whom it passed (with lots nos. 15 and 16) to Harry W. Hauck and wife by one of 1st of June 1937. In 1962 the Township of Livingston purchased Lots 15 through 20 for a historical museum and to complement the adjacent municipal park.

United States Department of the Interior
Heritage Conservation and Recreation Service
National Register of Historic Places
Inventory—Nomination Form

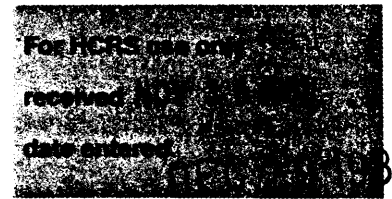

Continuation sheet

Item number 9

Page 1

9. BIBLIOGRAPHY

Thomas Force House

Bassett, William B., compiler and ed., and Poppeliers, John, ed., Historic American Buildings Survey of New Jersey, Catalog of the Measured Drawings, Photographs and Written Documents in the Survey, Newark, N. J., New Jersey Historical Society, 1977, p.74.

Cook, Lewis C., Supervising Historian HABS - NJ - 556, Data Sheets, The William Force House (Records of the Historic American Buildings Survey, National Park Service), Washington D. C., Library of Congress, Prints and Photographs Division, N. D., 4 pp.

Cook, Lillas Collins, Pioneers of Old Northfield, Livingston, New Jersey, Tribune Publishing Co. 1953, pp. 2-5, 19.

Daughters of the American Revolution, 1945 Home of C.P.L. Force, Revolutionary Soldier, 1941.

Force, Thomas, Last Will and Testament dated January 22, 1822, Essex Co., N. J. Recorded in Book D. of Wills, April 10, 1827, pp. 473-475.

Force, Thomas, Inventory of Estate of Thomas Force, April 10, 1827, and recorded in Book F of Inventories for Essex Co., N. J. pp. 67-71.

The Franklin Survey Company, Atlas of Boroughs of Caldwell, North Caldwell, West Caldwell, Essex Fells and Roseland, Townships of Caldwell and Livingston, Essex County, New Jersey, Volume B., Philadelphia, Pennsylvania. The Franklin Survey Company, 1933, Plates 20, 23, 24.

Groff, Sibyl, New Jersey's Historic Houses, A Guide to Homes Open to the Public, South Brunswick and New York, A. L. Barnes and Co. 1971, pp. 104-107.

Harrison, Freeman, Flames Above the Riker, Vignettes of Old Livingston, Livingston, New Jersey, Freeman Harrison Publisher, 1965, pp. 66, 94.

Historic American Buildings Survey, compiler and ed., Historic American Buildings Survey Catalog of the Measured Drawings and Photographs of the Survey in the Library of Congress, March 1, 1941., Washington, D. C. U.S. Government Printing Office, 1941, (Reproduced by National Technical Information Service, Springfield, Va.) p. 231.

United States Department of the Interior
Heritage Conservation and Recreation Service
National Register of Historic Places
Inventory—Nomination Form

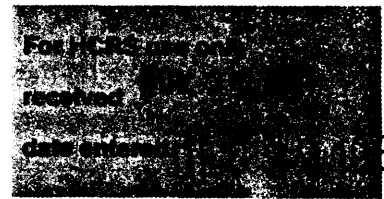

81

Continuation sheet

Item number 9

Page 2

9. BIBLIOGRAPHY (Continued)

Historic American Buildings Survey, Survey No. N.J. 556, Measured Drawings William Force House (Records of the Historic American Buildings Survey, National Park Service), Washington, D. C. Prints and Photographs Division, 1939, Sheets Numbered 1-17.

Kiser, Ellis, Atlas of Essex County, New Jersey, Volume 3, Philadelphia, Pennsylvania, A. H. Mueller and Company, 1906, plate 31.

Livingston Historical Society, A Brief History and Guide to the Force Homestead Prepared by the Livingston Historical Society, Livingston, N. J., Livingston Historical Society, 1964, 3 pp.

Livingston Historical Society, The Force House, Livingston, N.J., Livingston Historical Society, n.d., 3 pp.

Livingston Historical Society, Tour of the Force House, Livingston, N.J., Livingston Historical Society, n.d., 10 pp.

Livingston Historical Society, The Force House, Livingston, N.J., Livingston Historical Society, n.d., 5 pp.

Muller, Eric W. and Rusling, Frank V., The Livingston Historical Society, Inc. Volume Number One 1960-1965 (Scrapbook), Livingston, N. J. 1960-65, 135 pp.

Munro, Patricia, An Analysis of a Potential Small Museum: The Force Home, Livingston, New Jersey. Livingston Public Library, Vol. 15, Private Papers, 1978, 23 pp.

Nelson, William, ed. Documents Relating to the Colonial History of the State of New Jersey Volume XXIV, Extracts from American Newspapers Relating to New Jersey Vol. V, 1762-1765, (Archives of the State of New Jersey), Paterson, N. J., The Call Printing and Publishing Co., 1902, p. 76.

Nelson, William, ed. Documents Relating to the Colonial History of the State of New Jersey Volume XXIV, Extracts from American Newspapers Relating to New Jersey Vol. VII, 1768-1769, (Archives of the State of New Jersey), Paterson, N. J., The Call Printing and Publishing Co., 1902, pp. 126-127.

United States Department of the Interior
Heritage Conservation and Recreation Service
National Register of Historic Places
Inventory—Nomination Form

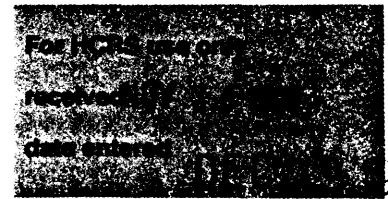

Continuation sheet

Item number 9

Page 3

9. BIBLIOGRAPHY (Continued)

Studley, Miriam V., Biographical Data on Deacon Thomas Force of Livingston; and Notes on Thomas Force, Livingston, N. J., 1980, 5 pp.

Studley, Miriam V., Force House, Livingston, N. J., 1980, 4 pp.

Swain, Bertha, Our Heritage, Livingston, N.J., Tribune Publishing Co., Livingston, N. J., 1976, 16 pp.

Township of Livingston, N. J., Assessor's Duplicate, Livingston Township - Volumes 1899-1905, Township of Livingston Tax Collector's Records.

Township of Livingston, N. J., Book of Tax Sales, Livingston Township, Essex County, New Jersey 1884-1909, Township of Livingston Tax Collector's Records.

Township of Livingston, N. J., Livingston Tax Duplicate, Volumes 1889-1898, Township of Livingston Tax Collector's Records.

West Essex Tribune, Anniversary Edition: A Special Supplement in Honor of Livingston's Sesquicentennial and Marking the 25th Anniversary of the West Essex Tribune Under the Ownership of William Klaber, Junior, Livingston, N. J., Tribune Publishing Co., September 5, 1963, p. 7, 11; 22-24.

West Essex Tribune, "Visit To Livingston's Past: The Force Home" (newspaper article), Livingston, N. J., Tribune Publishing Co., April 10, 1975, p. 20.

WPA Writer's Program, Livingston, The Story of a Community - Caldwell, New Jersey. Progress Publishing Co. 1939 166 pp.

MAPS CONSULTED

Map of Essex County, New Jersey, With the Names of Property, etc. from actual surveys by J. C. Sidney, published by Hiram A. Belding, Newark, New Jersey, 1850.

Map of Essex Country, New Jersey c. 1859 Whitloch's, New Haven, Ct. 1859.

United States Department of the Interior
Heritage Conservation and Recreation Service
National Register of Historic Places
Inventory—Nomination Form

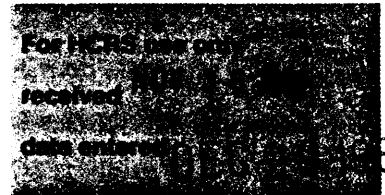

Continuation sheet

Item number 9

Page 4

9. BIBLIOGRAPHY (Continued)

Map of Essex County, New Jersey 1859 from Surveys Under the Direction of H. E. Walling's Map Department, published by Baker and Tilden, New York, New York 1859.

Township's of Livingston and Caldwell 1890 (Property Ownership Map), Entered According to the Act of Congress in the Year 1890 by E. Robinson in the Office of the Librarian of Congress at Washington, D. C.

Livingston Township 1906 Plate 31 - Property Ownership Map.

Livingston Township 1813, Map by Stanley B. Paton, Livingston, New Jersey, May 1963.

Condit Family Cook House

Biographical and Genealogical History of the City of Newark and Essex County, New Jersey, New York and Chicago. The Lewis Publishing Company, 1898, 2 volumes.

The Franklin Survey Company, Atlas of Boroughs of Caldwell, North Caldwell, West Caldwell, Essex Fells and Roseland, Townships of Caldwell and Livingston, Essex County, New Jersey, Volume B, Philadelphia, Pennsylvania, Franklin Survey Company 1933, Plates 20, 23, 24.

The Heritage Committee, Borough of Roseland, Centreville, Roselyn, Roseland, The History of a Community, Morristown, N. J. Mark Lithographers 1976 41 pp.

Kiser, Ellis, Atlas of Essex County, New Jersey, Volume 3, Philadelphia, Pennsylvania, A. H. Mueller and Company, 1906, plate 31.

Livingston Historical Society, The Force House, undated pamphlet, 4 pp.

Groff, Sibyl, New Jersey's Historic Houses A Guide To Homes Open To The Public, South Brunswick and New York, A. L. Barnes and Co. 1971 pp. 104-107.

Swain, Bertha, Our Heritage, Livingston, New Jersey, Tribune Publishing Co., Livingston, New Jersey 1976, 16 pp.

United States Department of the Interior
Heritage Conservation and Recreation Service
National Register of Historic Places
Inventory—Nomination Form

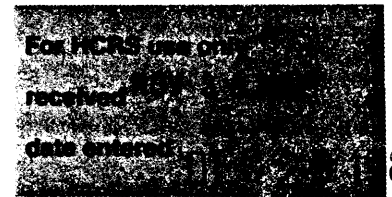

Continuation sheet

Item number 9

Page 5

9. BIBLIOGRAPHY (Continued)

Township of Livingston, New Jersey Assessor's Duplicate, Livingston Township - Volumes 1899-1901, 1902-1903, 1904-1905, Township of Livingston Tax Collector's Records.

Township of Livingston, New Jersey Book of Tax Sales, Livingston Township, Essex County, New Jersey, 1884-1909, Township of Livingston Tax Collector's Records.

Township of Livingston, N. J., Livingston Tax Duplicate, volumes 1889-1898.

West Essex Tribune, West Essex Tribune, Inc., publisher, Livingston, New Jersey, Newspaper articles and pictures: July 30, 1964, August 6, and 13, 1964, September 10, 1964, July 1, 1976 (Bicentennial Supplement p.30).

W.P.A. Writer's Program, Livingston, The Story of A Community, Caldwell, New Jersey, Progress Publishing Co., 1939, 166 pp.

MAPS CONSULTED

Map of Essex County, New Jersey, With the Names of Property, etc., from actual surveys by J. C. Sidney, published by Hiram A. Belding, Newark, New Jersey, 1850.

Map of Essex County, New Jersey, c.1859, Whitlock's, New Haven, Ct., 1859.

Map of Essex County, New Jersey, 1859, From Surveys Under The Direction of H. F. Walling's Map Department, published by Baker and Tilden, New York, New York, 1859.

Township's of Livingston and Caldwell 1890 (Property Ownership Map), Entered According to the Act of Congress in the Year 1890 by E. Robinson in the Office of the Librarian of Congress at Washington, D.C.

Livingston Township 1906, Plate 31 - Property Ownership Map.

**United States Department of the Interior
Heritage Conservation and Recreation Service**

**National Register of Historic Places
Inventory—Nomination Form**

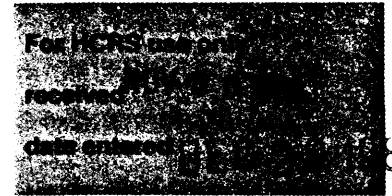

Continuation sheet

Item number 10

Page 1

10. GEOGRAPHICAL DATA

On December 10, 1962, the Township of Livingston, Essex County, New Jersey, purchased the Thomas Force House and property at 366 South Livingston Avenue, containing .5437 acres of land. The Condit Family Cook House was relocated to a rear portion of this site in August of 1964 to preserve it from demolition. The property reference is Block 160, Lots 15-20.

As shown by the Community Facilities Inventory Map, the Condit Family Cook House and Thomas Force House property is surrounded by Township of Livingston owned parklands on three sides and by an Essex County road on the fourth boundary.

Theophilus Ward/Thomas Force
House and Condit Family cook
house NOV 30 1981
Livingston Township
Essex County, New Jersey

DEC 29 1981

= .5437 Acres

MAP REFERENCE:

Tax Map
Livingston, N.J.
Sheet 43

no date

scale - 1"=100'

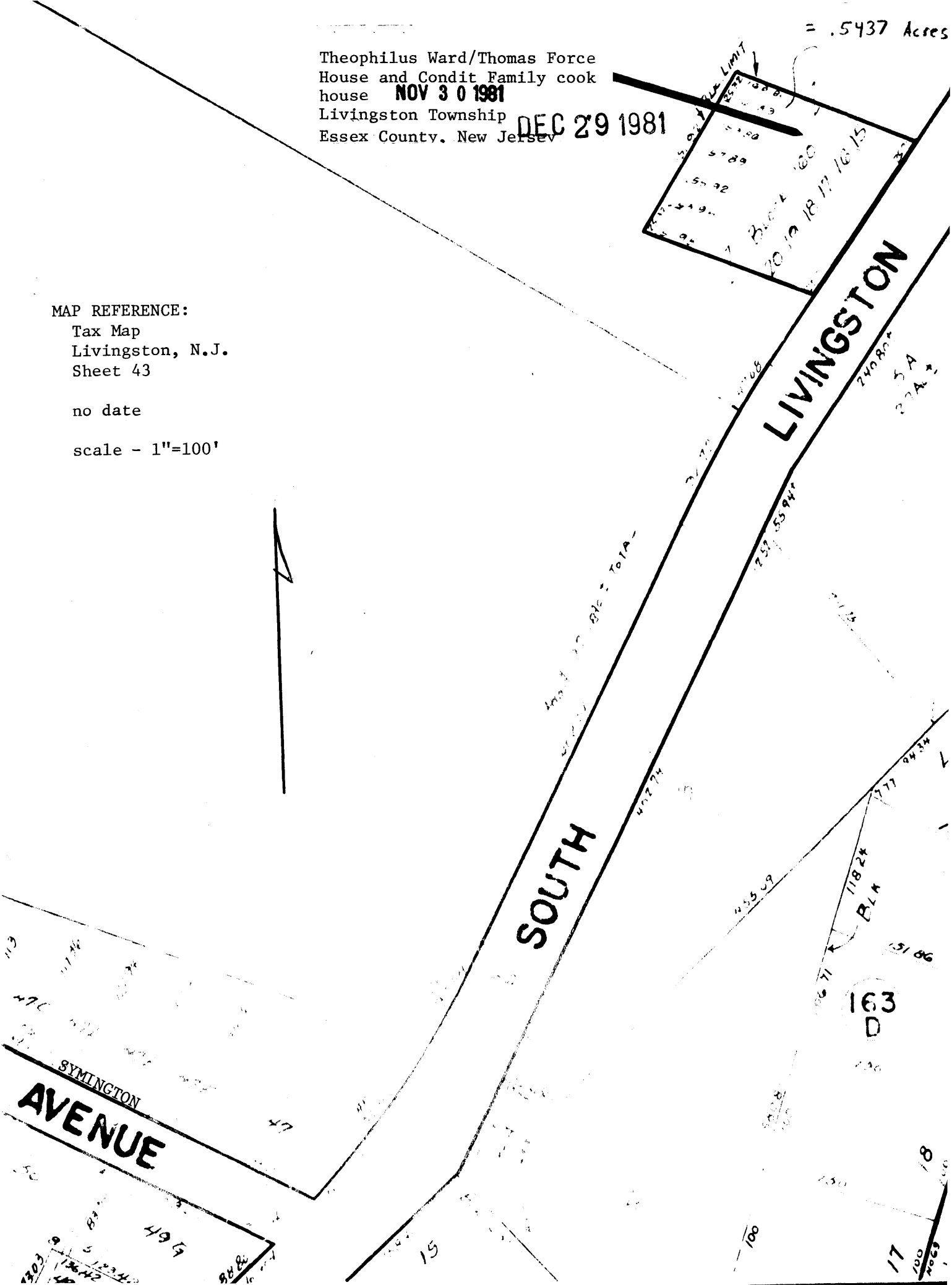

Ward/Force House

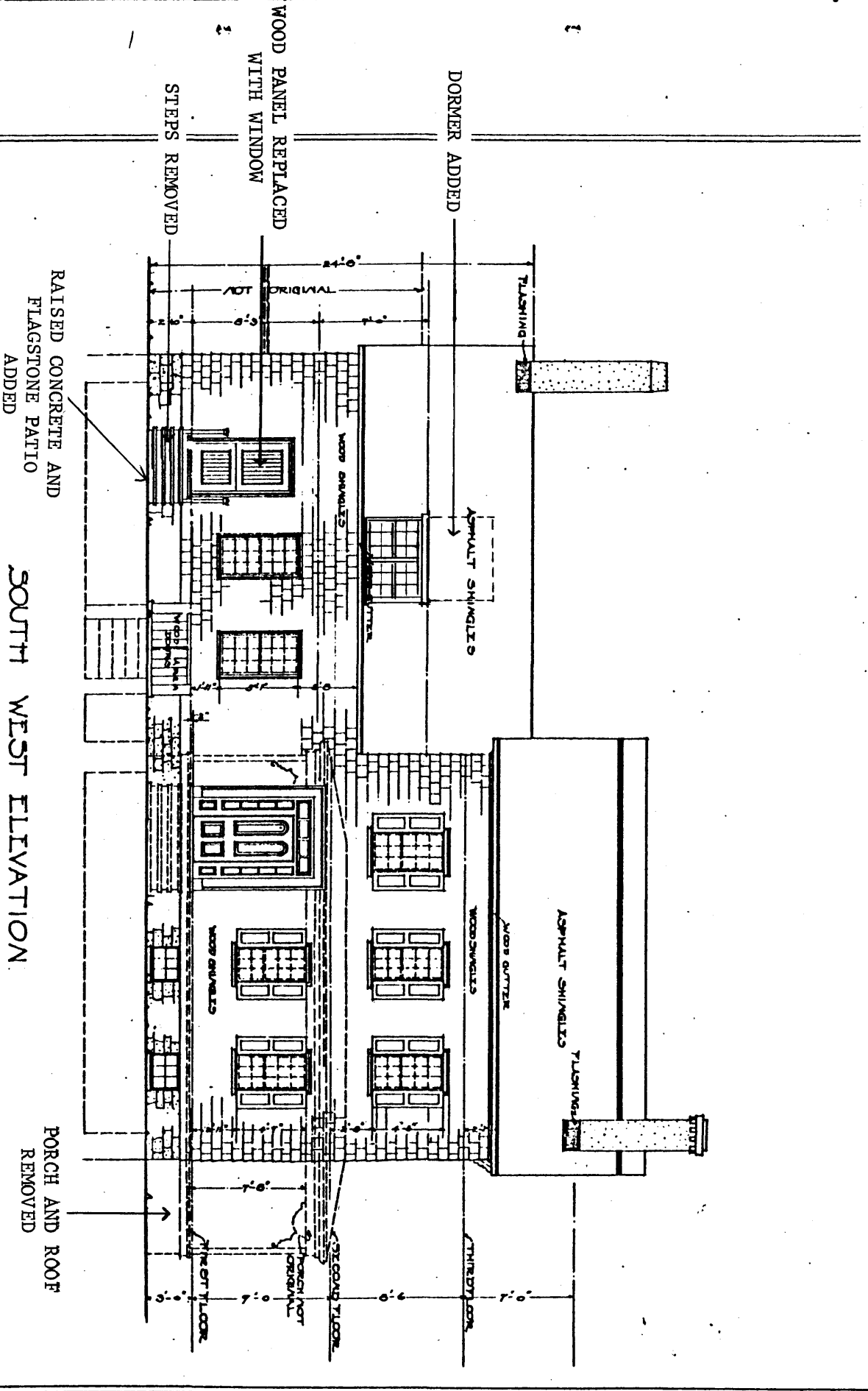

HANOUSKEPTER, D.L.

RAISED CONCRETE AND
FLAGSTONE PATIO
ADDED

SOUTH WEST ELEVATION

PORCH AND ROOF
REMOVED

WORKS PROGRESS ADMINISTRATION
OFFICIAL PROJECT # 666-2E-345-3
NATIONAL PARK SERVICE, DIVISION OF PLACES AND HISTORIC MONUMENTS

WILLIAM FORCE HOUSE
STATE OF CONNECTICUT
345 SOUTH LIVINGSTON AVE. LIVINGSTON, ESSEX COUNTY, NJ

SHEET NO. NJ35b

HISTORIC AMERICAN
BUILDINGS SURVEY
SHEET 3 OF 7 SHEETS

DEC 29 1981

NOV 3 0 1981

SOUTH EAST ELEVATION

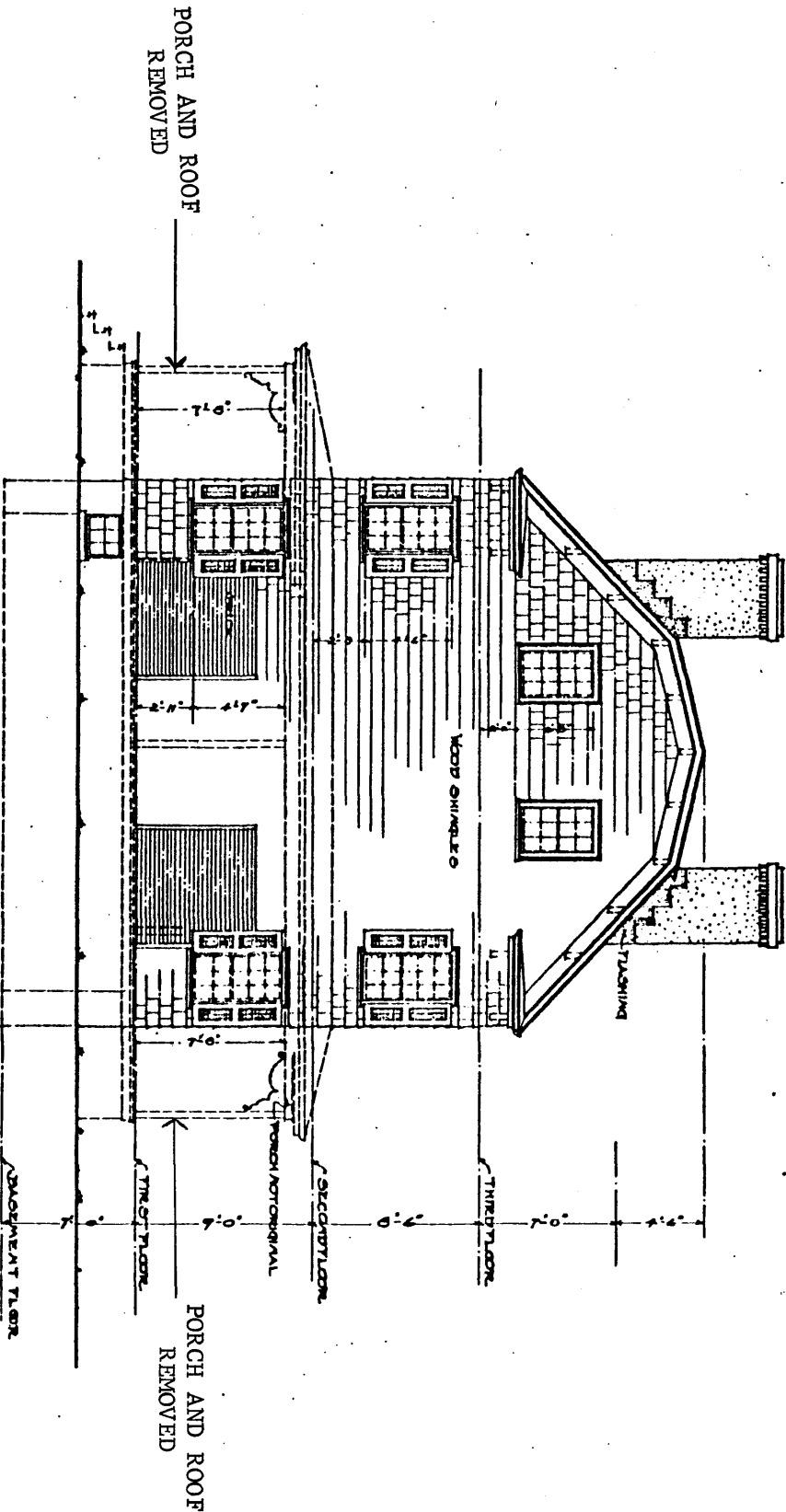

HANOUSKEEY ER. DEL.

YORK-PROGRESS-ADMINISTRATION
 OFFICIAL PROJECT # 643-22-3-43
 FEDERAL BUREAU OF SURVEY OF THE DEPARTMENT OF THE INTERIOR
 NATIONAL PARK SERVICE, BUREAU OF LAND MANAGEMENT

WILLIAM FORD HOUSE
 343-30-LIVINGSTON AVE. LIVINGSTON CO. NY

1/4" = 1'-0"
 METRIC



NO. 556

HISTORIC AMERICAN BUILDINGS SURVEY SHEET 6 OF 17 SHEETS

DEC 29 1981

NOV 3 0 1981

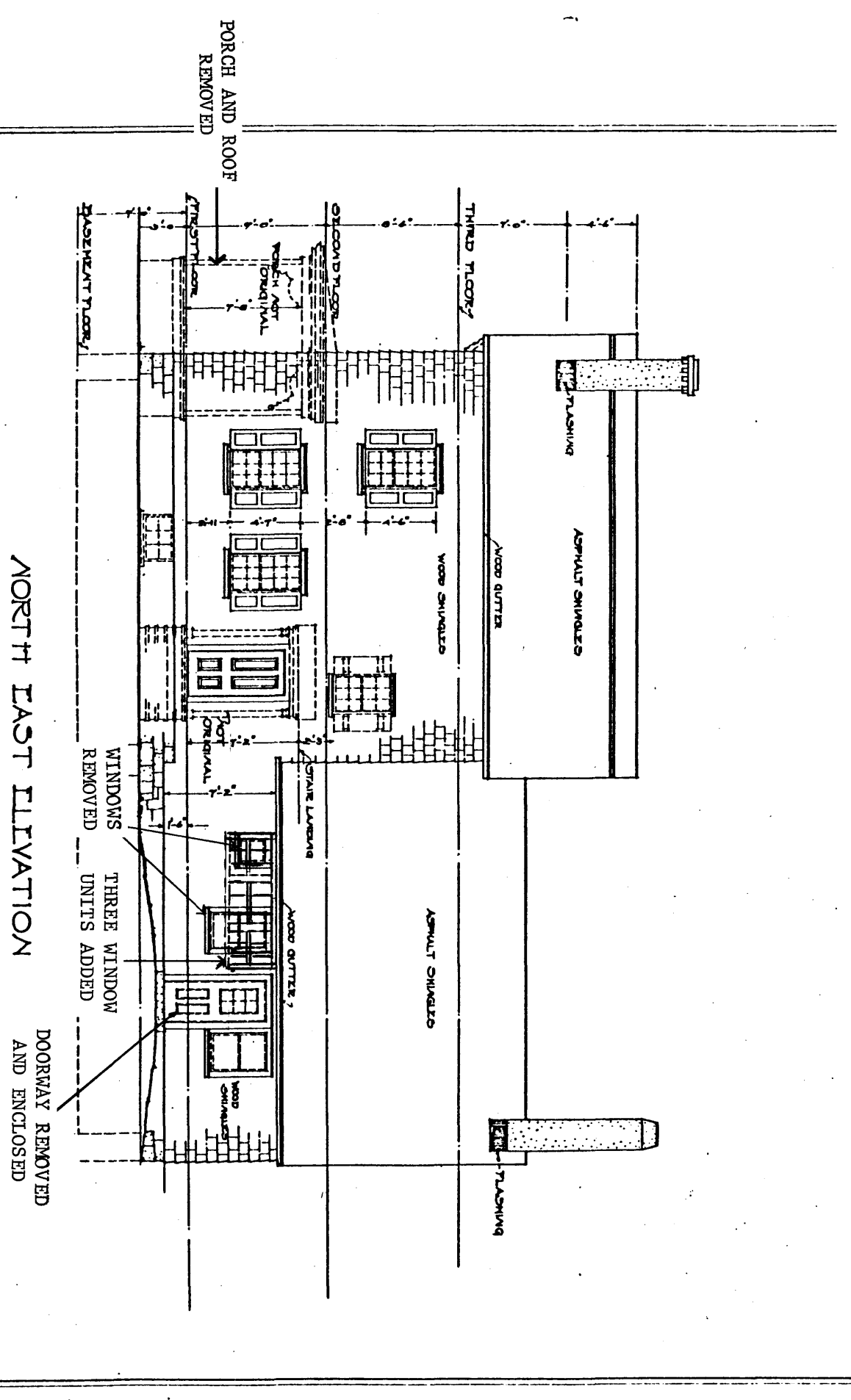

HANOUSKIE PER.

WORKS PROGRESS ADMINISTRATION
 OFFICE OF HISTORIC PRESERVATION
 FEDERAL BUREAU OF SURVEY
 1015 N. WASHINGTON AVENUE
 WASHINGTON, D.C. 20540

WILLIAM FORCE HOUSE
 3430 LIVINGSTON AVE. LIVINGSTON, MISSISSIPPI COUNTY, MO.



NO. 536

HISTORIC AMERICAN BUILDINGS SURVEY
 SHEET 6 OF 17 SHEETS

DEC 29 1981

NOV 30 1981

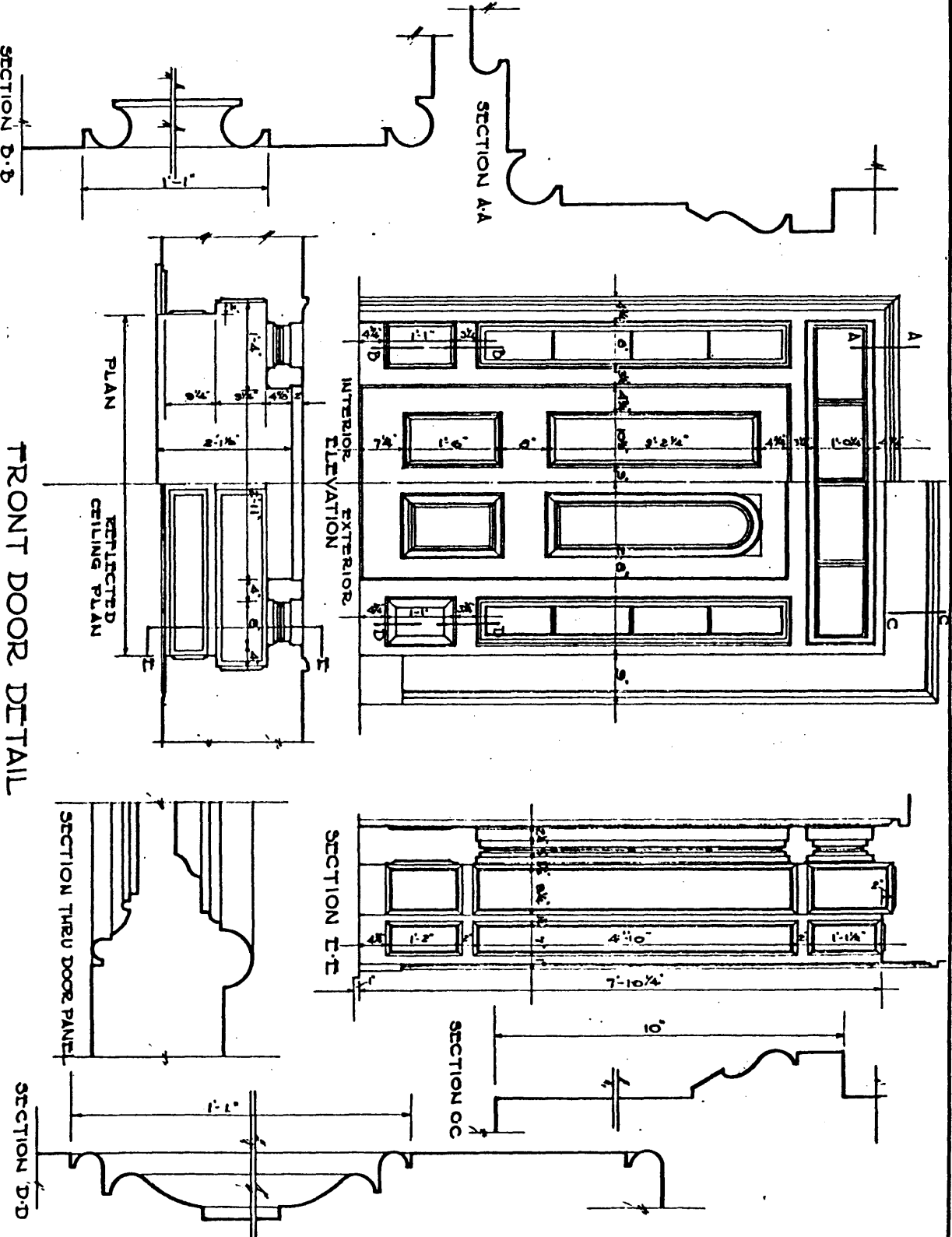

FRONT DOOR DETAIL

EXTERIOR DOORWAY TO MAIN HALLWAY
SOUTHEAST ELEVATION

A. SCHIANI - DEL.

WORKS - PROGRESS ADMINISTRATION
OFFICIAL PROJECT N° 885 - 22 - 3 - 45
PROJETS DE TRAVAUX OFFICIELS N° 885 - 22 - 3 - 45

WILLIAM FORCE HOUSE
5945 DO LIVINGSTON AVE • LIVINGSTON • ROSKEX COUNTY • N.J.

SCALE: FULL SIZE
1" = 1'-0"
METRIC

NO 556

HISTORIC AMERICAN BUILDINGS SURVEY
SHEET 10 OF 17 SHEETS

NOV 3 0 1981

DEC 29 1981

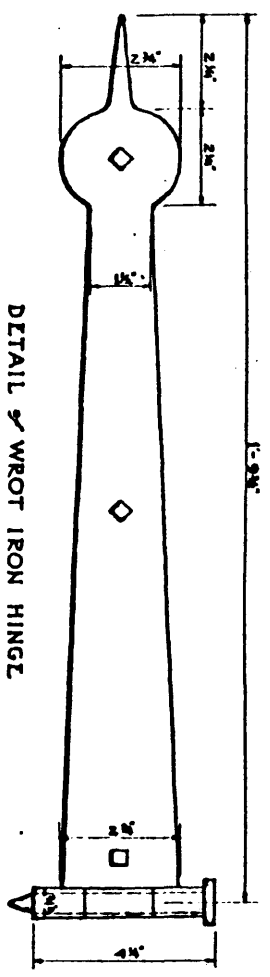

DETAIL OF WROUGHT IRON HINGE

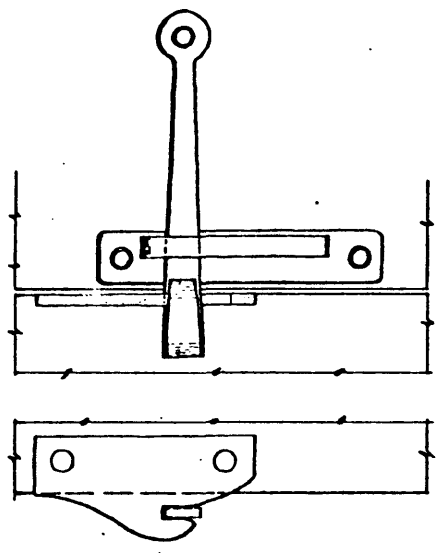

TYPICAL DOOR LATCHES

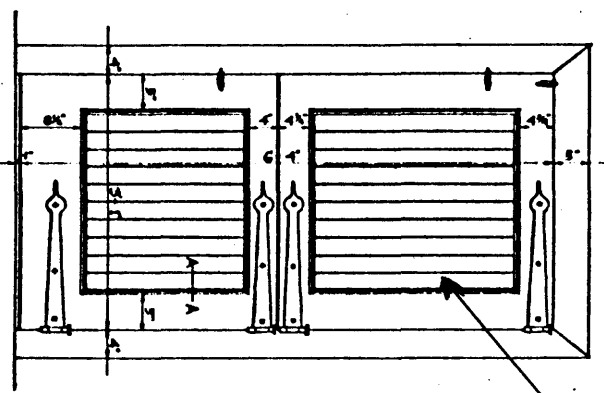

ELEVATION OF DUTCH DOOR
— ORIGINAL KITCHEN —

WOOD PANEL REPLACED WITH WINDOW

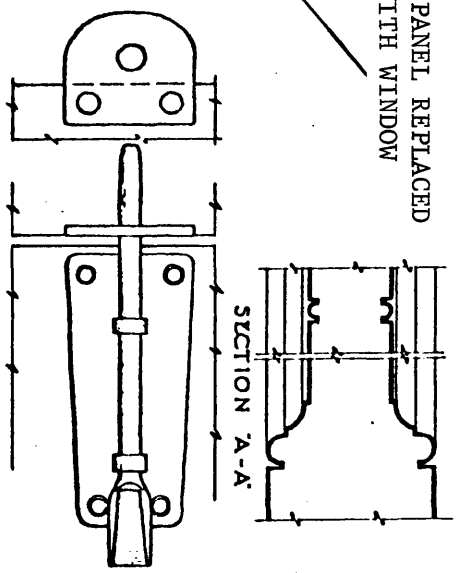

DETAILS OF LATCHES
— DUTCH DOOR —

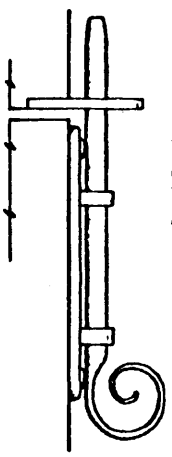

MISCELLANEOUS DETAILS

EXTERIOR DOORWAY TO ORIGINAL MAIN ROOM SOUTHWEST ELEVATION

JOSEPH L. HERBOLD — DPL.

WORKS PROGRESS ADMINISTRATION
OFFICIAL PROJECT NO. 65-22-3-A-3
NATIONAL PARK SERVICE, BUREAU OF PLACES AND THINGS

WILLIAM FORCE HOUSE
NAME OF STRUCTURE
343-50 LIVINGSTON AVE. LIVINGSTON-TXSEX COUNTY-N.Y.

FULL SIZE
6" = 1'-0"
1" = 1'-0"
METRIC

SHEET NO. H-1556

HISTORIC AMERICAN BUILDINGS SURVEY SHEET 11 OF 17 SHEETS

DEC 29 1981

NOV 30 1981

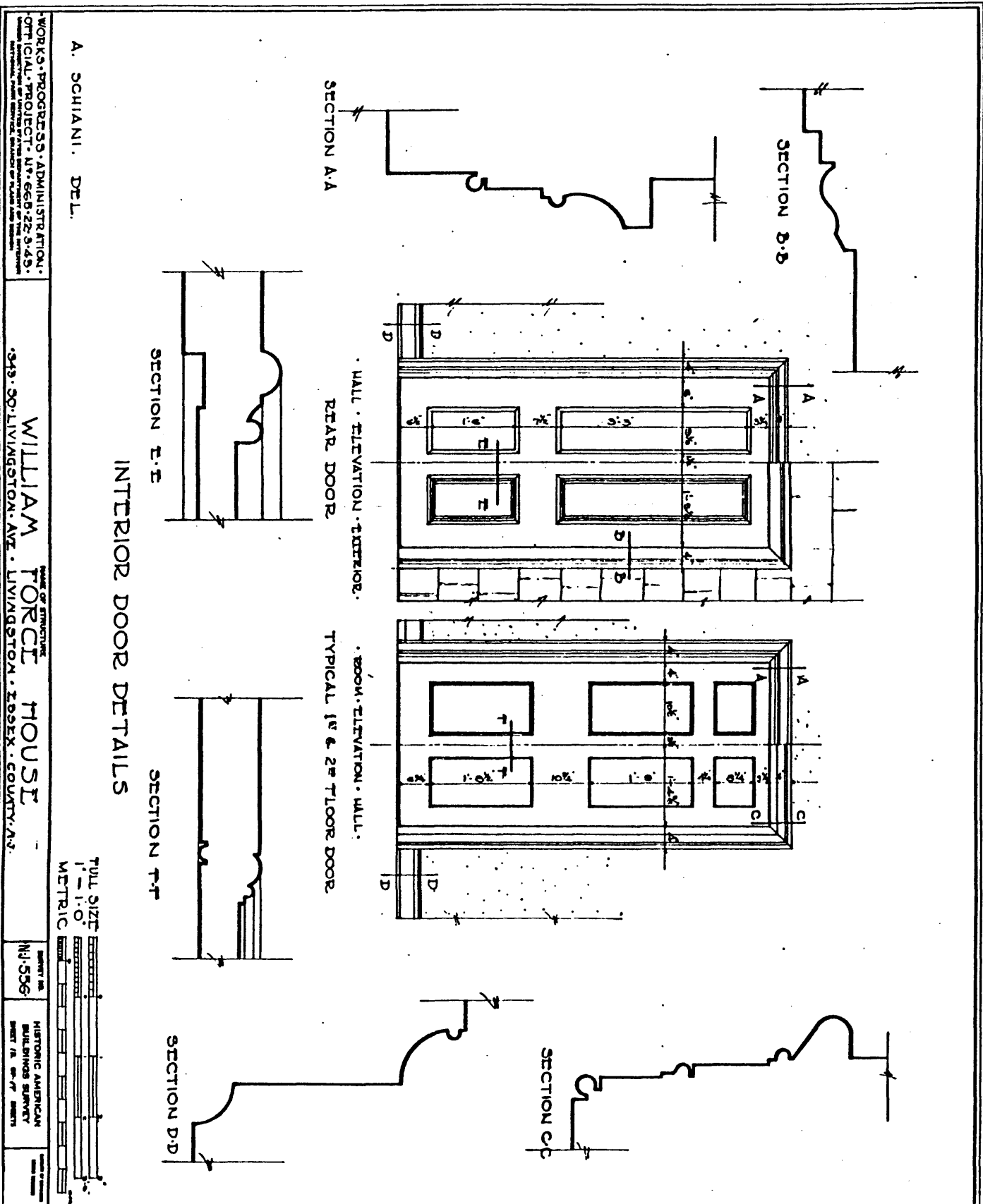

DEC-29-1981

NOV 30 1981

A. SCHIANI, DEL.

INTERIOR DOOR DETAILS

WORKS • PROJECTS • ADMINISTRATION •
 OFFICIAL • PROJECT: 117-658-22-3-4-5
 CONTRACT: 117-658-22-3-4-5

WILLIAM FORCE HOUSE
 349 SOUTH LIVINGSTON AVE • LIVINGSTON • INDEX • COUNTY • AV.

HISTORIC AMERICAN BUILDINGS SURVEY
 SHEET 18 OF 17 SHEETS

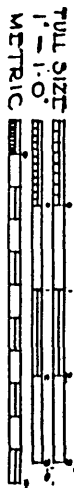

INTERIOR FIRST FLOOR
 MAIN HALLWAY
 NORTHWEST ELEVATION

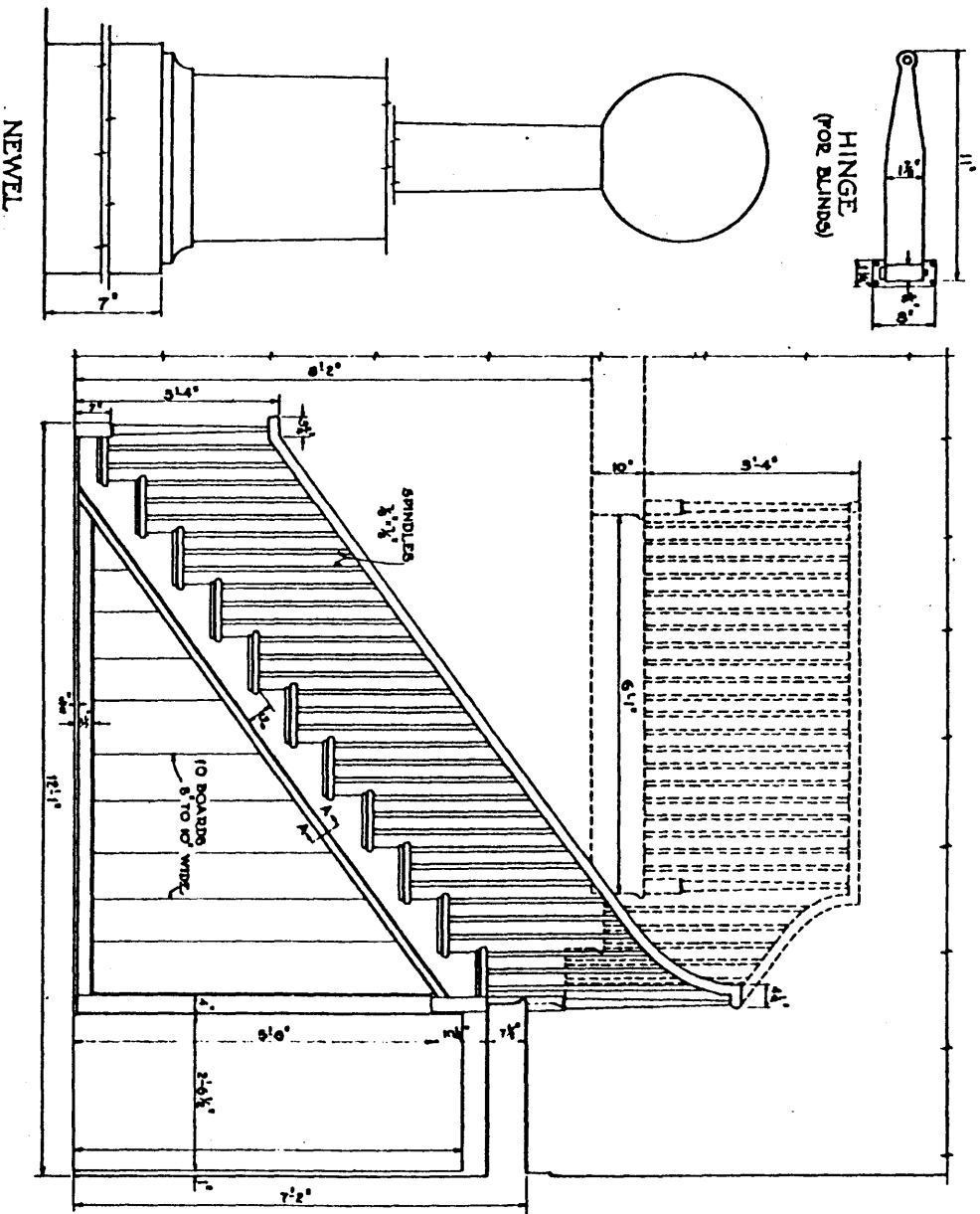

STAIRWAY & BLIND DETAILS

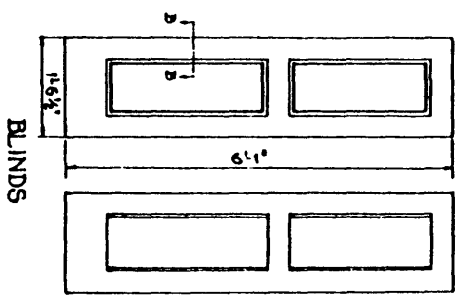
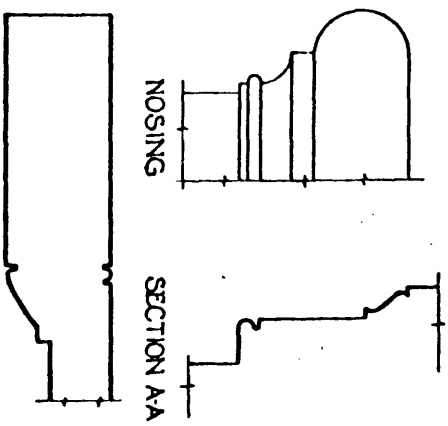

WOBKIS PROGR 66 ADMINISTRATION
 OFFICIAL PROJECT N° 66-2-27-3-43
 NATIONAL ARCHITECTURAL RECORD SERVICE
 5. CHRISTOPHER-ERSON, DEL.

WILLIAM FORCE HOUSE
 343-30 LIVINGSTON AVE. LIVINGSTON, LOUISIANA 70301

1/10-0
 1/10-0
 FULL SIZE
 METRIC

SHWYER 101
 N1536
 HISTORIC AMERICAN
 BUILDINGS SURVEY
 SHEET 15 OF 17 SHEETS

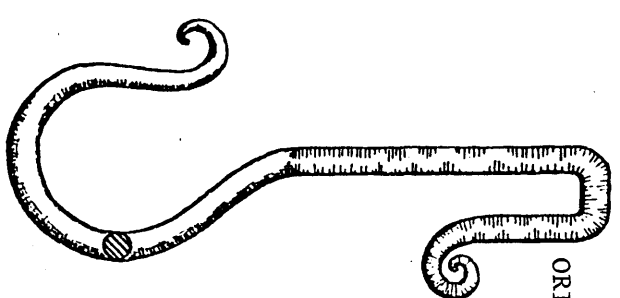

W.I. POT HOOK

ORIGINAL MAIN ROOM FIREPLACE ELEVATION
NORTHWEST ELEVATION

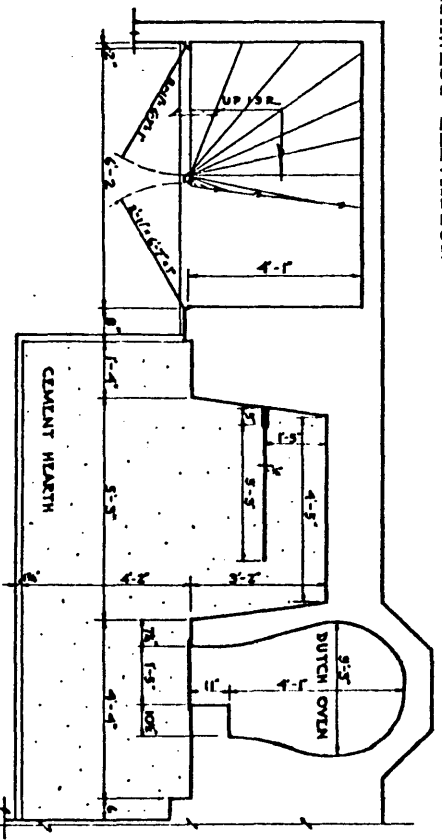
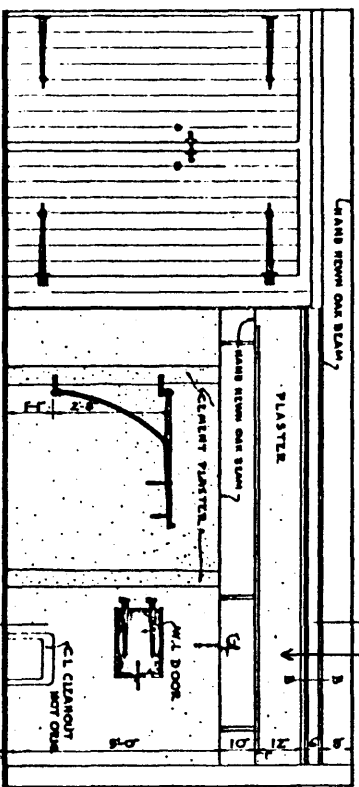

PLAN

DETAILS OF MANTEL - ROOM N^o 1

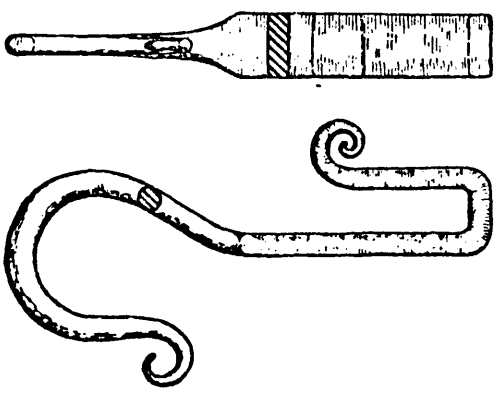

WROTE IRON POT HOOK

SECTION A-A

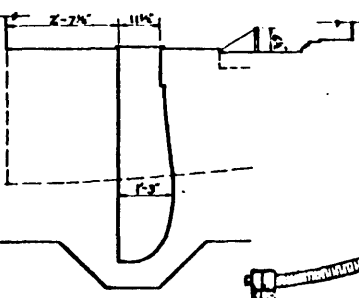

W.I. CRANE
W - 1'-0"

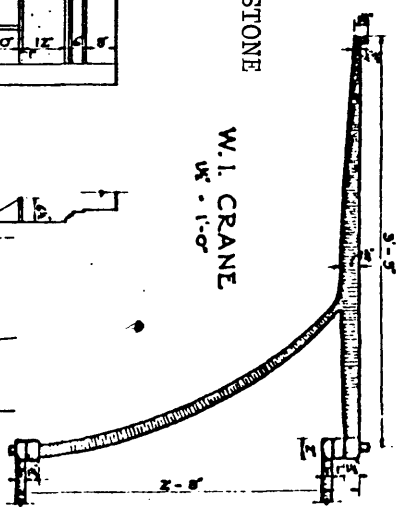

WORKS PROJECTS ADMINISTRATION
OFFICIAL PROJECT NO 645-22-3-43
NATIONAL HISTORIC SURVEY DIVISION OF PLANNING AND DESIGN

JOSEPH BARBOJKA - DEL.

WILLIAM FORCE HOUSE
343-50-LIVINGSTON AVE - LIVINGSTON TOWNSHIP - COVINGTON - LA.
INDEX - COUNTY - NV

FULL SIZE
1/4" = 1'-0"
METRIC
SERIES 100
NO. 556
HISTORIC AMERICAN BUILDINGS SURVEY SHEET 14 OF 14 SHEETS

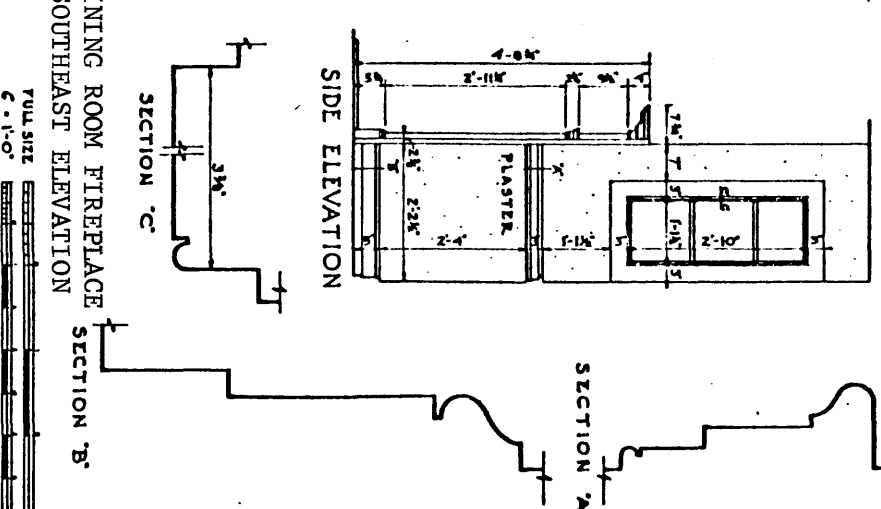
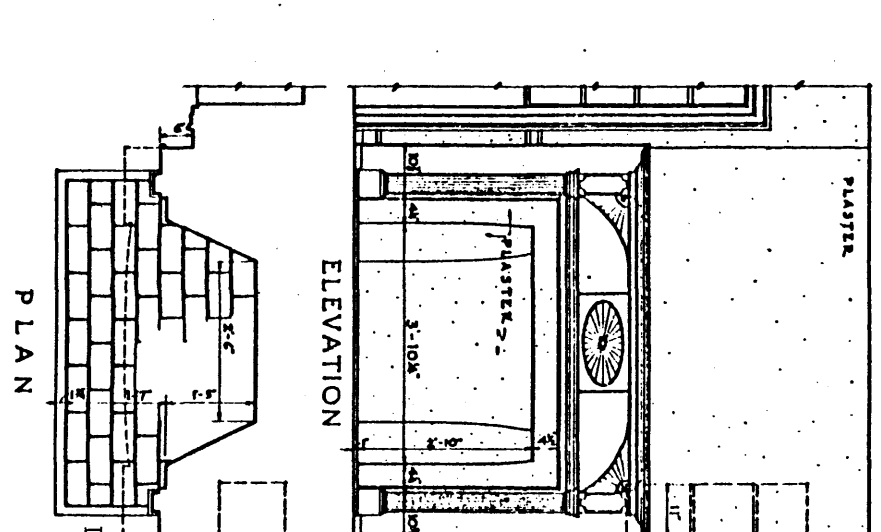
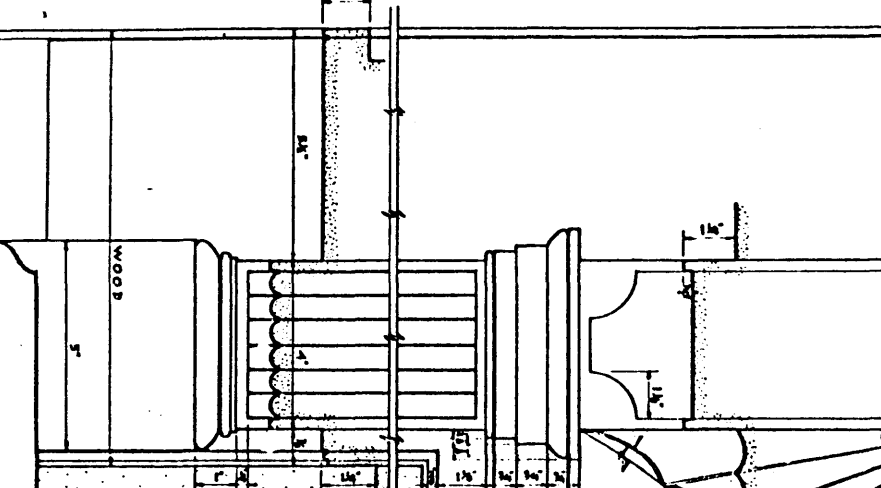
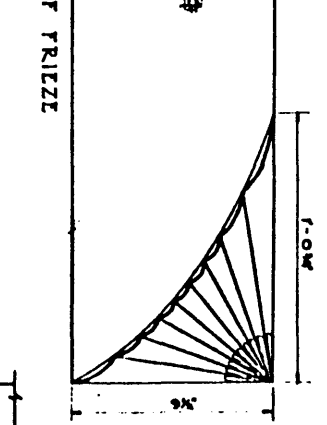
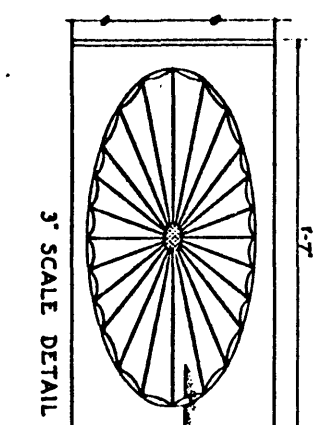
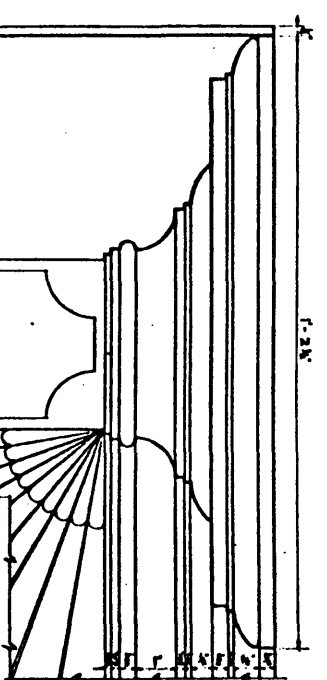

6' SCALE DETAIL OF PILASTER

DETAILS OF MANTEL ROOM NO 2

WORKS - PROGRESS - ADMINISTRATION
 OFFICIAL PROJECT NUMBER 23-5-43
 NATIONAL ARCHITECTURAL ARCHIVE OF THE UNIVERSITY OF CALIFORNIA

WILLIAM FORCE HOUSE
 NAME OF STRUCTURE
 343-30-LIVINGSTON-AVE - LIVINGSTON-1302X-COUNTY-A-N-J

HISTORIC AMERICAN BUILDINGS SURVEY
 SHEET 18 OF 17 SHEETS

REAR BEDROOM FIREPLACE - ROOM NO. 5 -
SOUTHEAST ELEVATION

MANTEL DETAILS

SITING ROOM FIREPLACE - ROOM NO. 3 -
SOUTHEAST ELEVATION

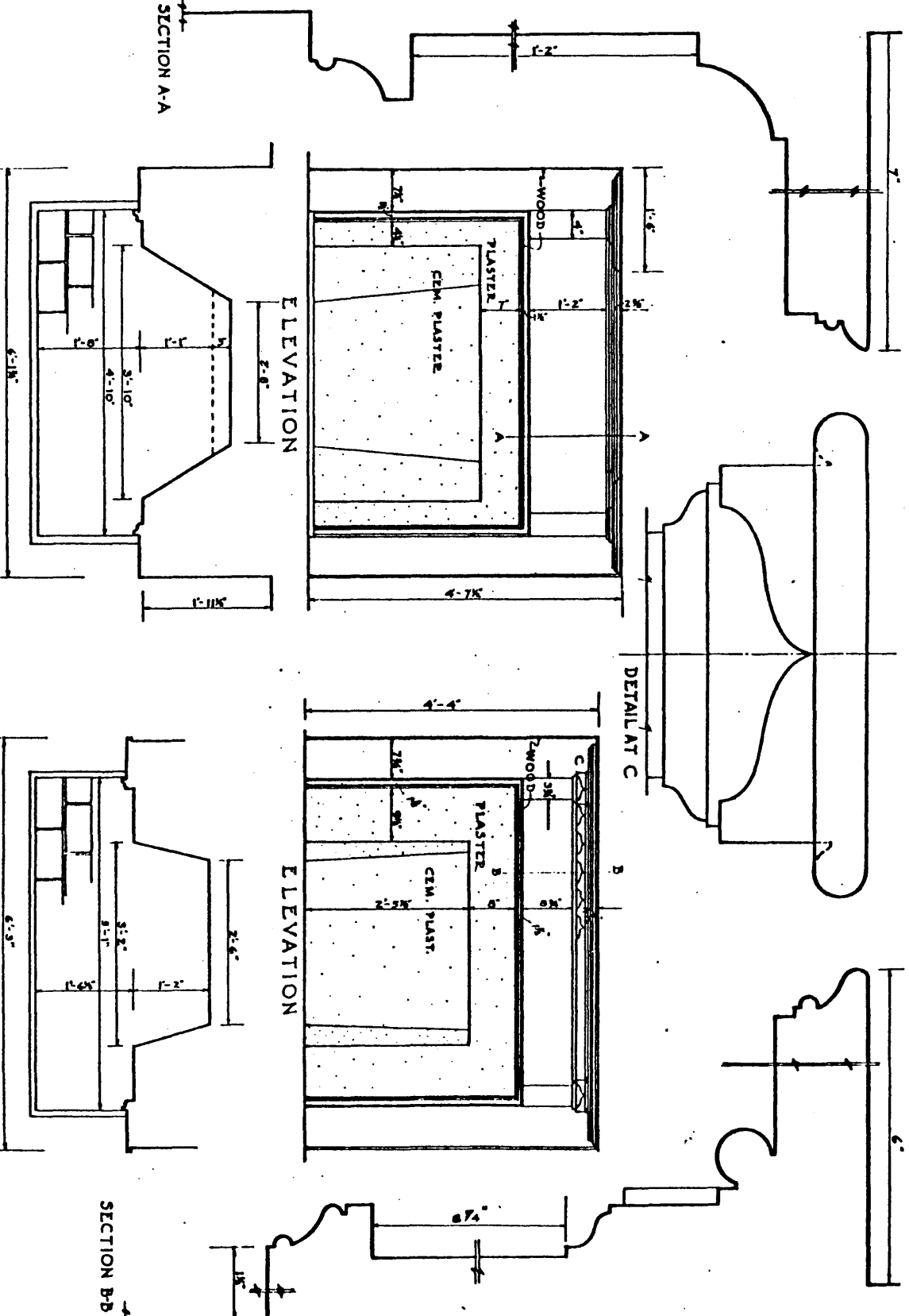

A. SCHIANI - DTL.

WORKS PROGRESS - ADMINISTRATION -
OFFICIAL PROJECT NUMBER 22-9-49 -
NATIONAL ARCHIVE SERVICE, DIVISION OF PUBLIC AFFAIRS

WILLIAM FORCE HOUSE
345-30-LIVINGSTON AVE - LIVINGSTON - SOSS-COUNTY - N.J.

HISTORIC AMERICAN BUILDINGS SURVEY
SHEET # 17 OF 17 SHEETS

FULL SIZE
1" = 1'-0"
METRIC

DEC 29 1981

NOV 30 1981

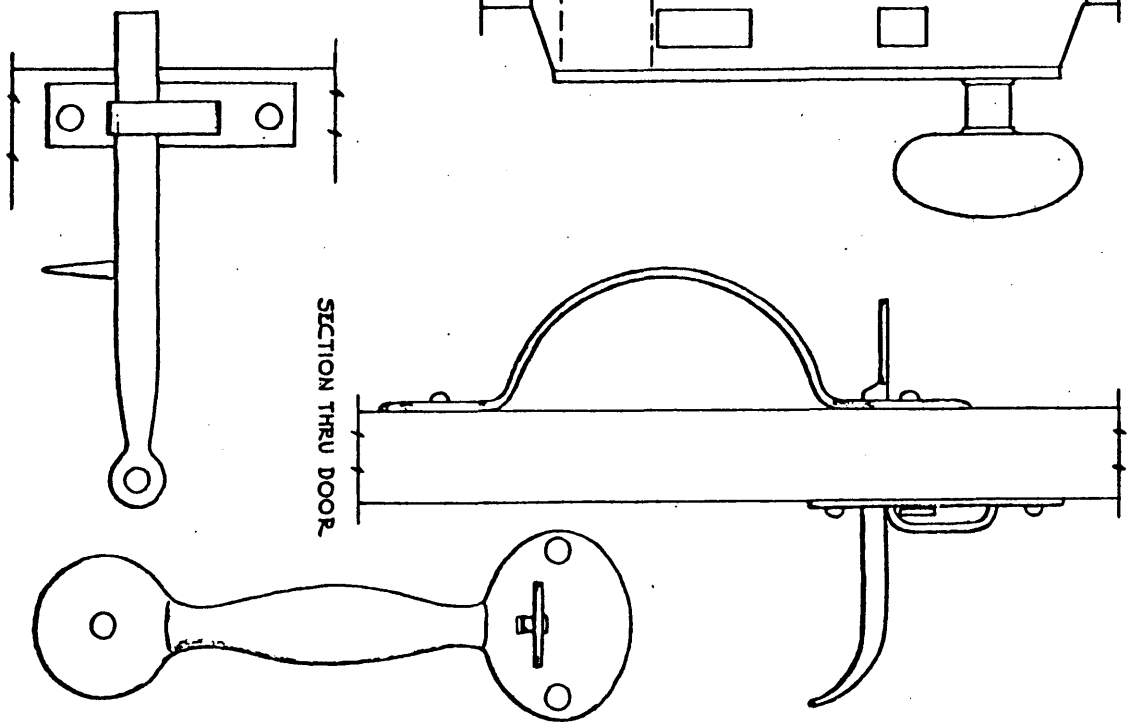
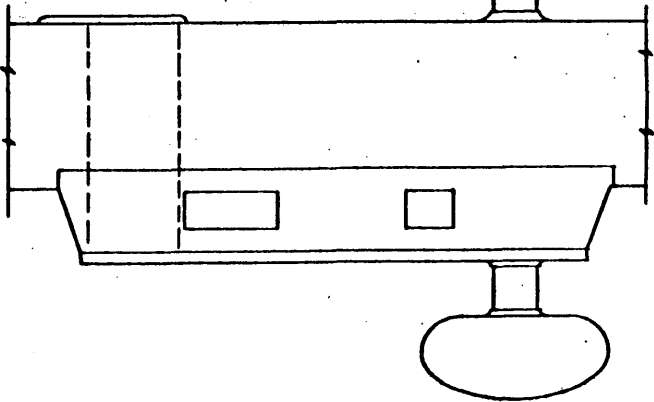
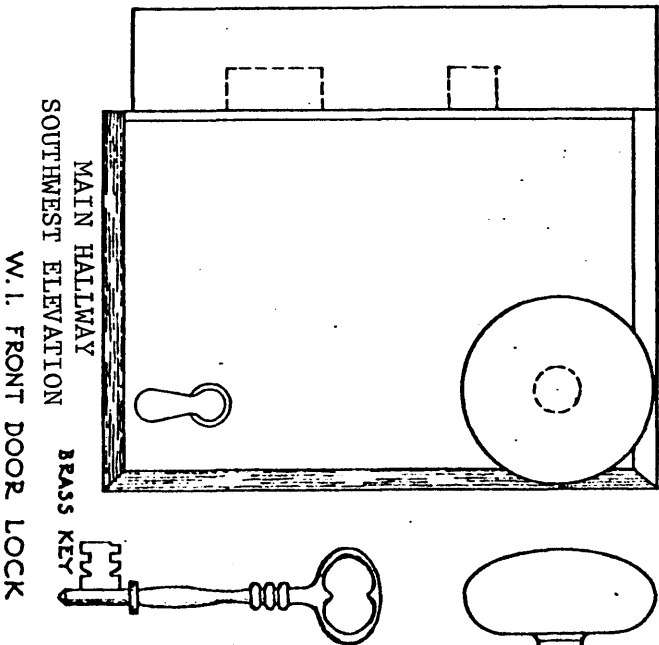

HARDWARE DETAILS

A. SCHIANI - DEL.

WORKS PROGRESS ADMINISTRATION
OFFICIAL PROJECT No 663-22-3-43

WILLIAM FORCE HOUSE
343-30 LIVINGSTON AVE. LIVINGSTON. ESSEX COUNTY, N.Y.

WORKS PROGRESS ADMINISTRATION
OFFICIAL PROJECT No 663-22-3-43

HISTORIC AMERICAN BUILDING SURVEY
SHEET 17 OF 17 SHEETS

FULL SIZE
METRIC



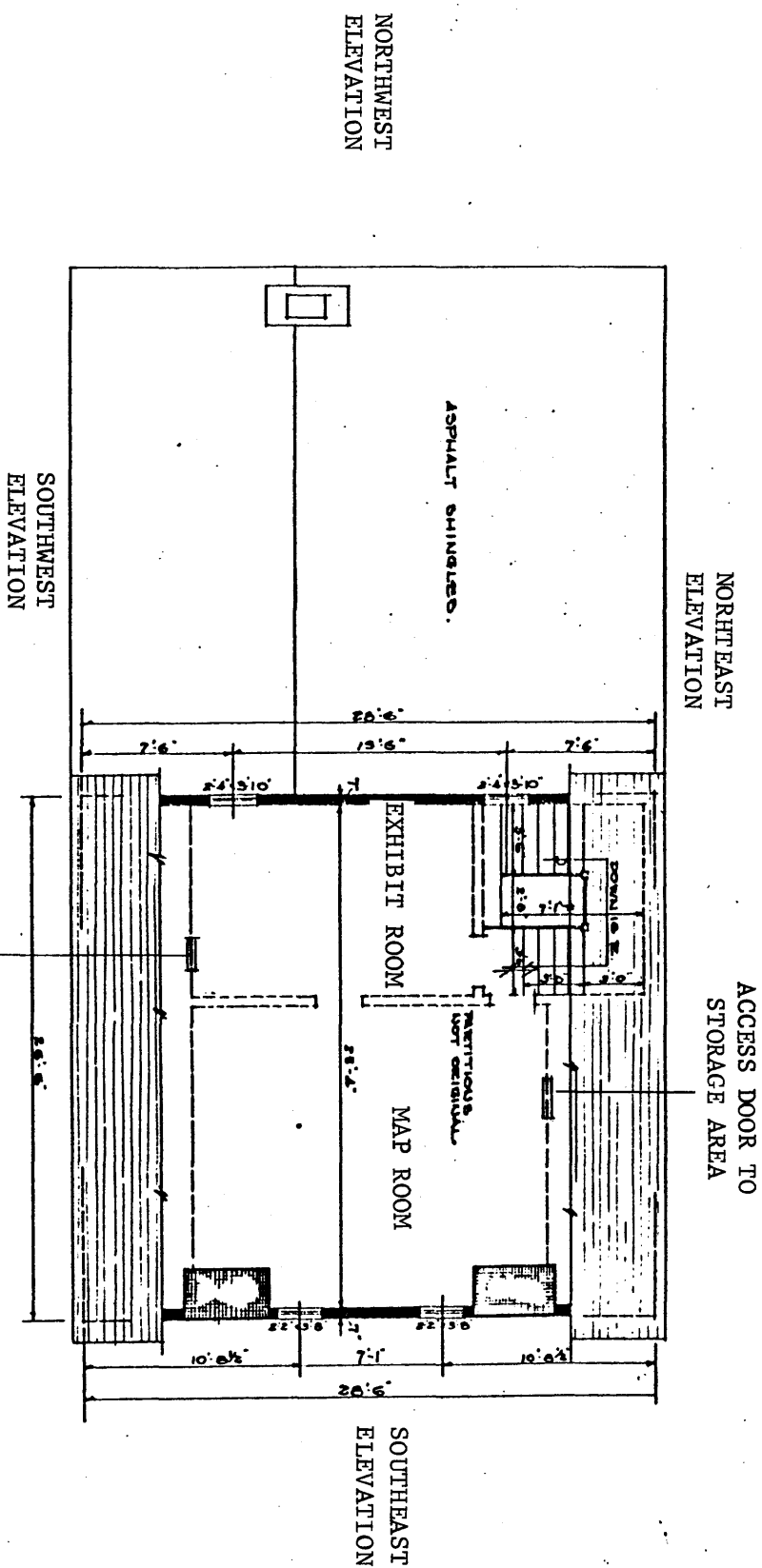
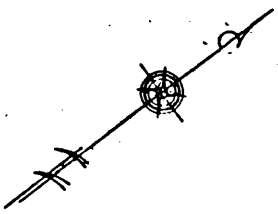

THIRD FLOOR PLAN

• LOLLY • M • HORECHANY • DEL •

WORKS PROGRESS ADMINISTRATION
 OFFICIAL PROJECT N° 665-22-3-4-b
UNIVERSITY OF MARYLAND SYSTEM DEPARTMENT OF THE HISTORIC ARCHITECTURE AND SURVEY DIVISION

WILLIAM FORCE HOUSE
 343 DO-LIVINGSTON AVE • LIVINGSTON • ISEX COUNTY • AV.



MATERIAL KEY
 FRAME (orig)
 FRAME (N.O.)
 DECK
 RANDON WITH PLANK FLOOR
 ALL SASH NOT ORIGINAL

PROJECT NO. NJ-556
 HISTORIC AMERICAN BUILDINGS SURVEY
 SHEET 4 OF 17 SHEETS

DEC 29 1981

NOV 30 1981

Ward/Force House

18th c.
19th c.

SECTION-AT-A

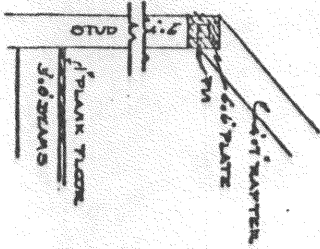

SECTION ON LINE A-A.

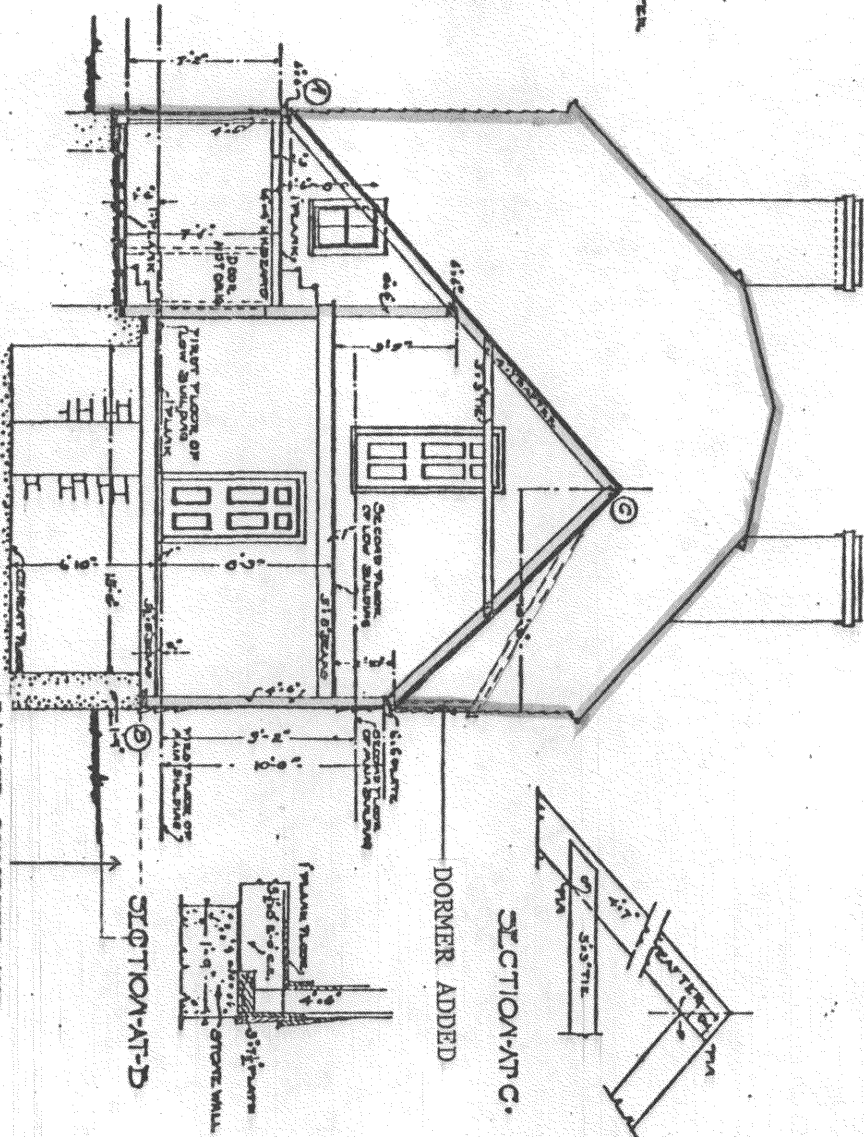

SECTION-AT-C.

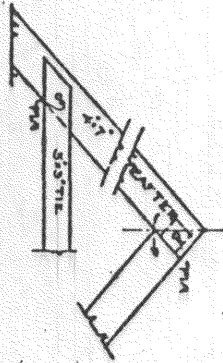

DORMER ADDED

SECTION-AT-B

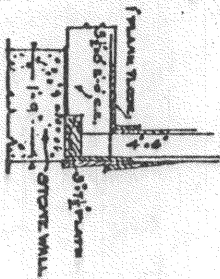

RAISED CONCRETE AND
FLAGSTONE PATIO
ADDED



THAMOUKXETEK.

WORKS • PROJECTS • ADMINISTRATION •
OFFICIAL PROJECT NUMBER 13-6-18 •
ALL RIGHTS RESERVED BY THE ARCHITECT •
NOT TO BE REPRODUCED OR TRANSMITTED IN ANY FORM OR BY ANY MEANS •

WILLIAM FORCE HOUSE
NAME OF STRUCTURE
43100 LIVINGSTON AVE • LIVINGSTON • ESSLER COUNTY • NJ •

SHRIMP NO. 10556 HISTORIC AMERICAN BUILDINGS SURVEY SHEET 3 OF 17 SHEETS

DEC 29 1981

NOV 3 0 1981

18th c.

19th c.

HYMNODUCKE PER. DEL.

WORKS PROJECTS ADMINISTRATION
OFFICIAL PROJECT NUMBER 48643-22-3-43
DATE: SUBJECT OF BUILDING AND LOCATION FOR THE INTERIOR
NATIONAL FIRE SERVICE BUREAU OF PLUMBING AND DESIGN

WILLIAM FORCE HOUSE
NAME OF STRUCTURE
343 80-11 WASHINGTON AVE. WASHINGTON EXETER COUNTY N.H.

NORTH WEST ELEVATION

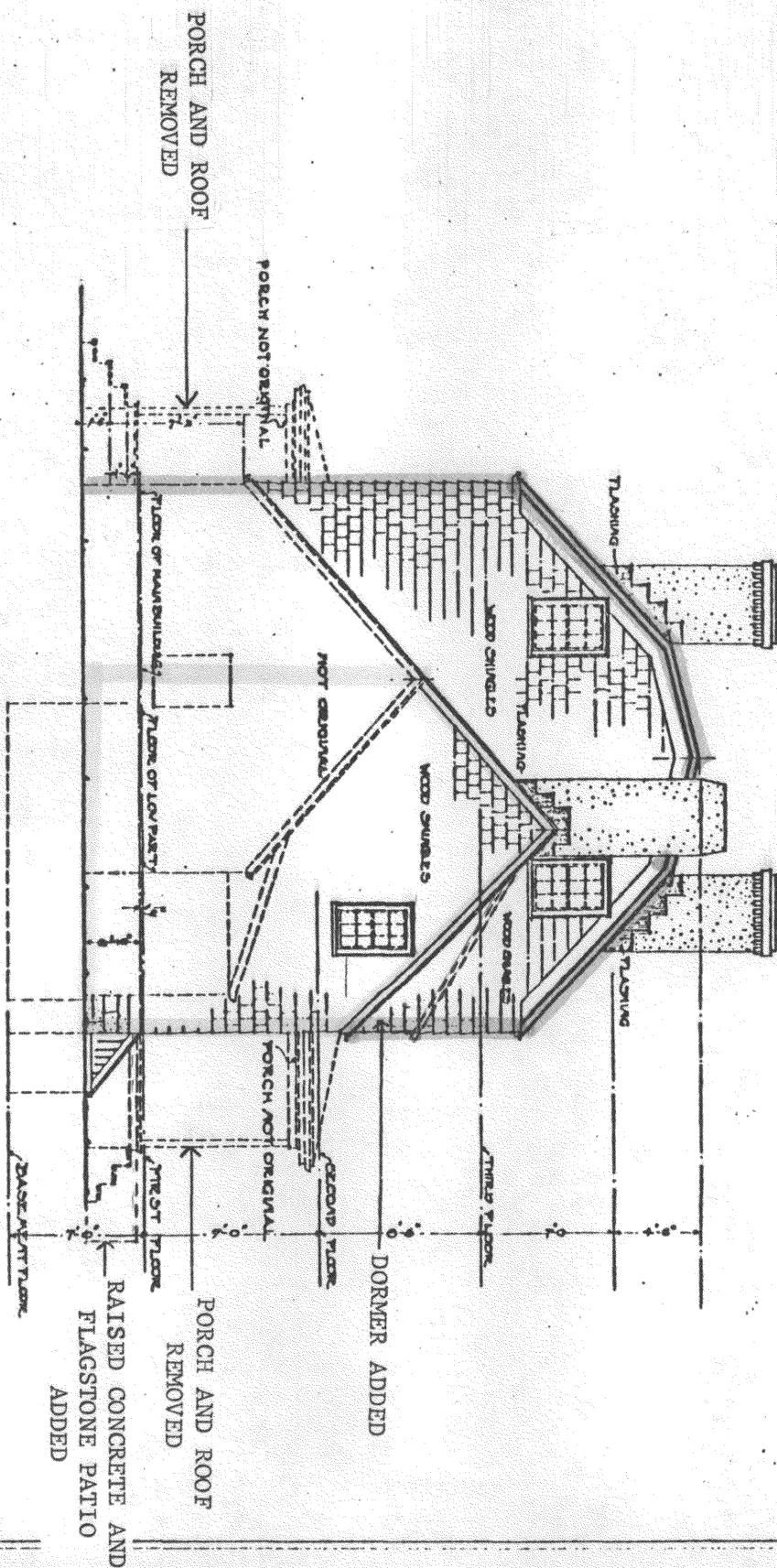

1/4" = 1'-0"
METRIC

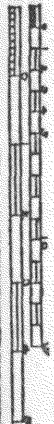

NOV 556

HISTORIC AMERICAN BUILDINGS SURVEY SHEET 7 OF 17 SHEETS

DEC 29 1981

NOV 9 1981 NOV 30 1981

18th c.

19th c.

THIS SECTION BUILT ON
A SLAB FOUNDATION

FOUNDATION FOR RAISED CONCRETE
AND FLAGSTONE PATIO

CELLAR PLAN

• LOUW. M. HOEBCHEM. P.E.L.

WORKS PROGRESS ADMINISTRATION
OFFICIAL PROJECT NO 668-23-9-43
CONSTRUCTION OF WARD'S FORCE HOUSE AND PATIO
AND FOUNDATION FOR RAISED CONCRETE AND FLAGSTONE PATIO

WILLIAM FORCE HOUSE
419-30 LIVINGSTON AVE. LIVINGSTON COUNTY, N.Y.

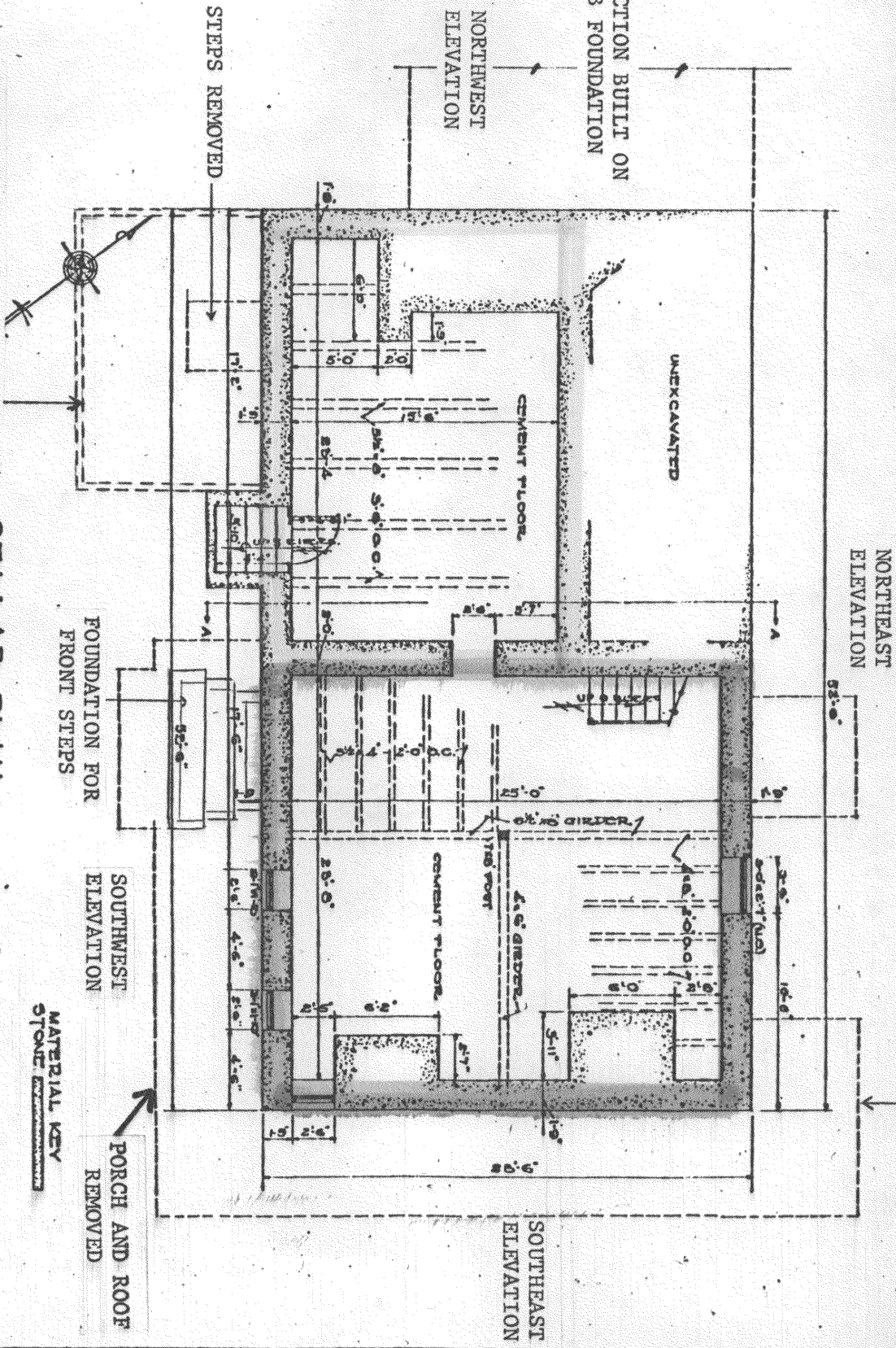

DEC 29 1981

NOV 3 0 1981

NY 556
HISTORIC AMERICAN
BUILDING SURVEY
SERIES 1 919 SERIES

Ward/Force House

THREE WINDOW UNITS ADDED

NORTHEAST ELEVATION

18th
19th

DOORWAY REMOVED AND ENCLOSED

PARTITION REMOVED

DOOR REMOVED

DOORWAY ADDED

CABINET REMOVED

PORCH AND ROOF REMOVED

FIREPLACE AND HEARTH ADDED

SEE SEPARATE SHEET FOR THIS SECTION OF HOUSE

NORTHWEST ELEVATION

STEPS REMOVED

RAISED CONCRETE AND FLAGSTONE PATIO ADDED

LOLLY M. WILCOX ARCHT. B.S. L.

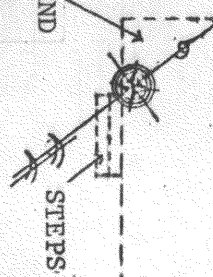

SOUTHWEST ELEVATION

STEPS REMOVED

PORCH AND ROOF REMOVED

FLAGSTONE CONCRETE AND BRICK STEPS ADDED

MATERIAL KEY
FRAME
BRICK
STONE
RANDOM WIDTH PLANK FLOOR
ALL STAIR NOT ORIGINAL

1/4" = 1'-0"
METRIC

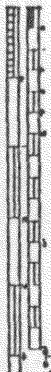

WORKS - PROCESS - ADMINISTRATION
OFFICIAL - PROJECT - No. 689 - ZP - 8-43
NATIONAL ARCHITECTURAL SOCIETY

WILLIAM FORCE HOUSE
STATE OF MICHIGAN
443 DO. LIVINGSTON AVT. LIVINGSTON, INDEX. COUNTY, A.U.

NOV 30 1921

DEC 20 1921

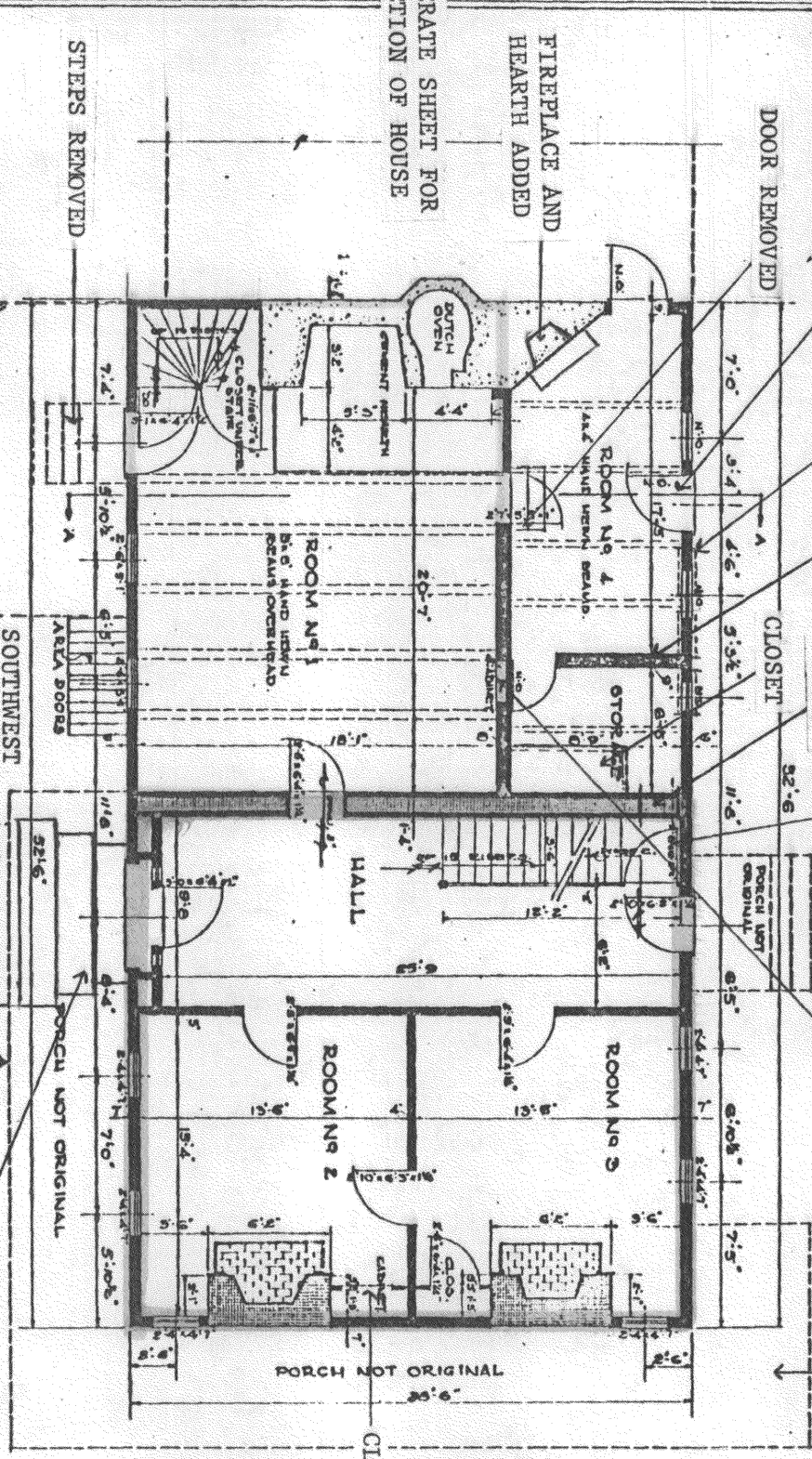

18th c.
19th c.

ACCESS DOORS TO STORAGE AREA
NORTHEAST ELEVATION

WOOD PANELING

ROOF AND PORCH REMOVED

ACCESS CLOSED OFF

NORTHWEST ELEVATION

STORAGE AREA

MUSEUM ROOM

UNFINISHED ATTIC
SANDON WITH PLANK FLOOR

SOUTHWEST ELEVATION

OPENING TO SECOND FLOOR CLOSED OFF

PARTITIONS ADDED

PORCH AND ROOF REMOVED

SECOND FLOOR PLAN

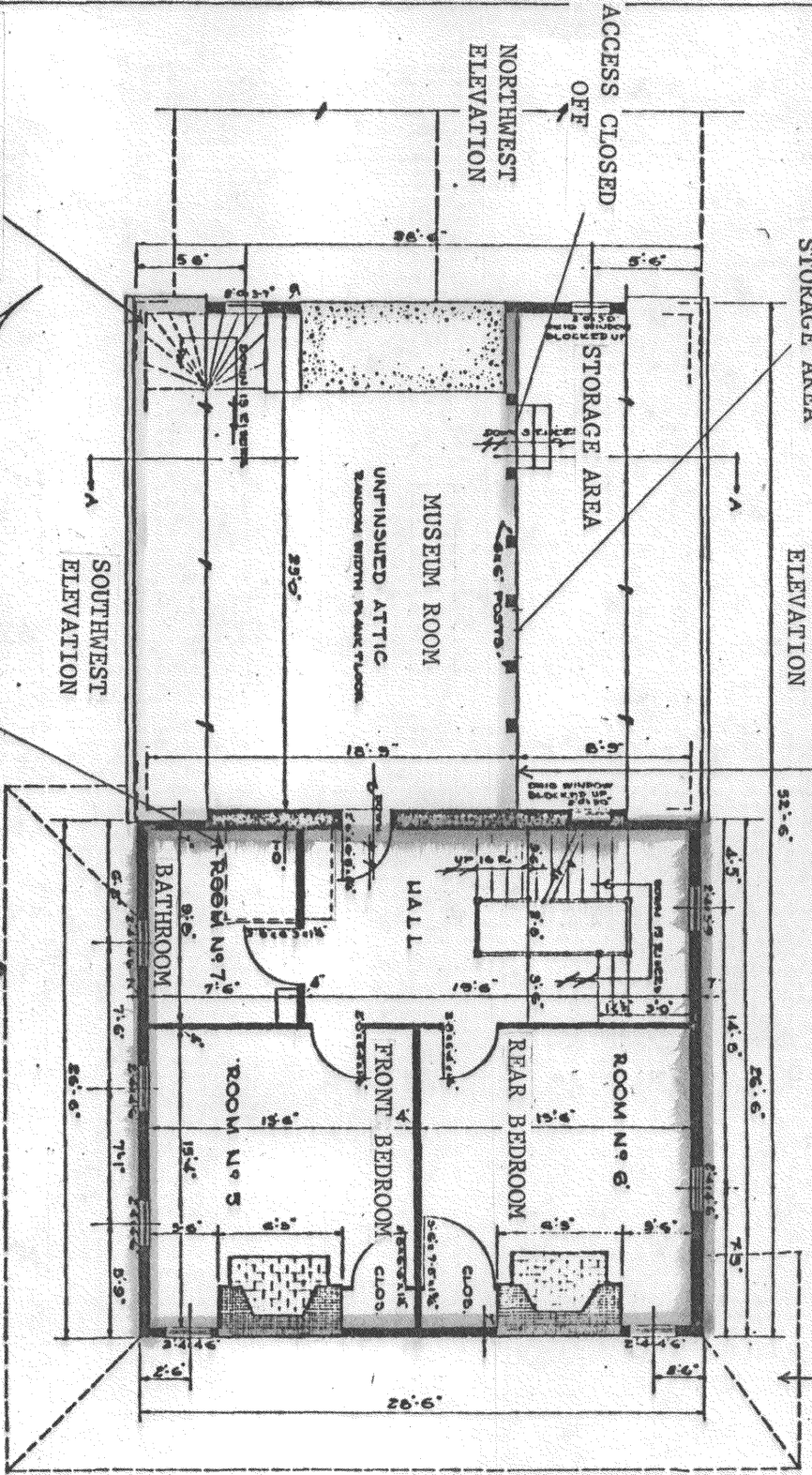

• LOLLY M. WORSCHNY, DEL.

WORKS - PROGRESS - ADMINISTRATION
OFFICIAL - PROJECT - N° 653-23 - 8-43

WILLIAM FORCE HOUSE
343-50 LIVINGSTON AVE • LIVINGSTON • EDEX COUNTY • NY

1/8" = 1'-0"
METRIC

MATERIAL KEY
 FRAME
 BRICK
 STONE
 SANDON WITH PLANK FLOOR
 ALL OTHER NOT ORIGINAL.

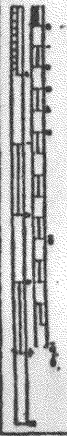

DEC 29 1981

NOV 3 0 1981

HISTORIC AMERICAN BUILDINGS SURVEY
SHEET 2 OF 17 SHEETS

SECOND FLOOR PLAN

18' 3 3/4"

SOUTHWEST
ELEVATION

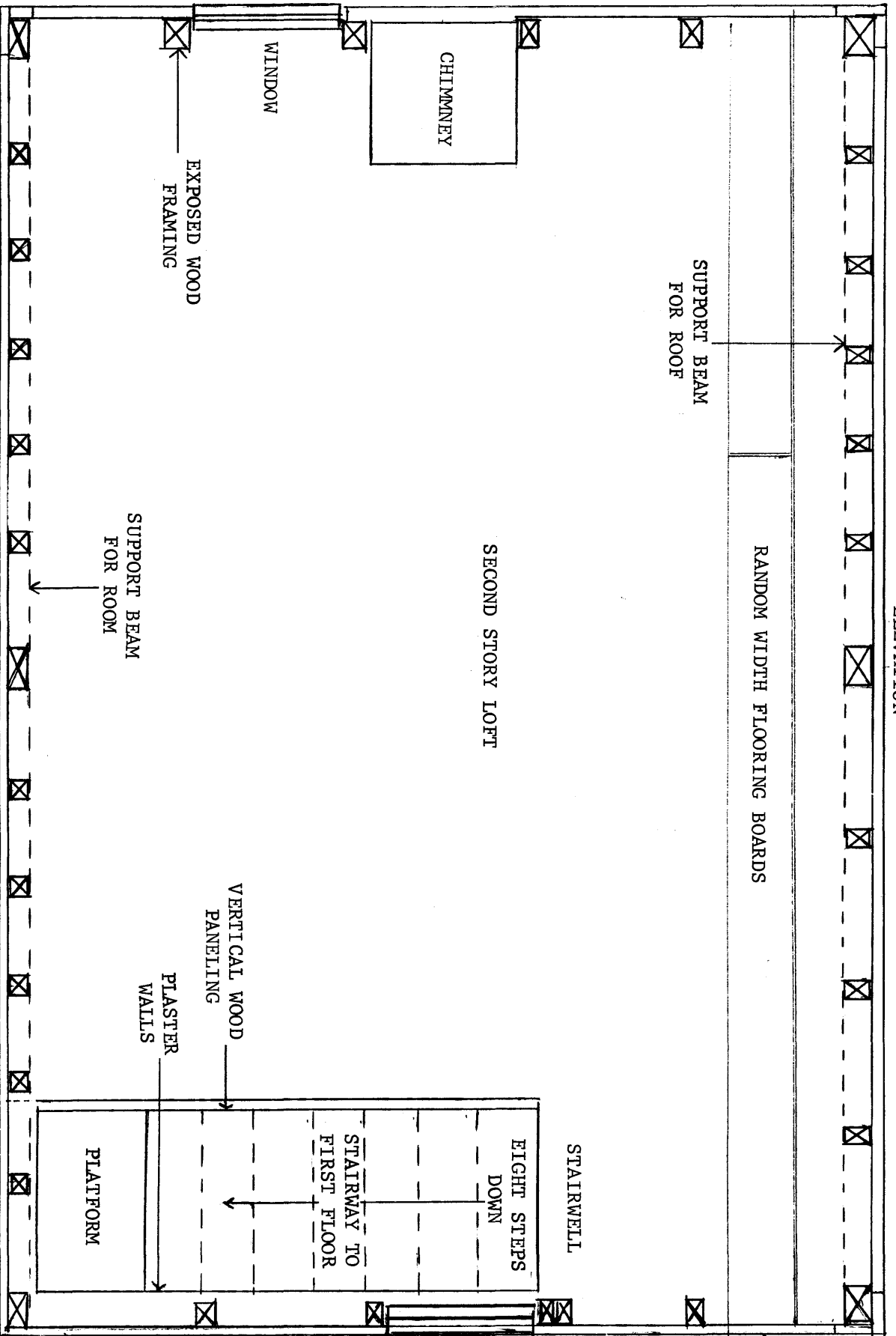

12' 3"

SOUTHEAST
ELEVATION

SECOND STORY LOFT

NORTHEAST
ELEVATION

NORTHWEST
ELEVATION

CLAPBOARD
SIDING

Ward/Force House

DRAWN BY: RUSSELL A. JONES, JR.
 ASSISTANT TO THE MANAGER
 TOWNSHIP OF LIVINGSTON
 ESSEX COUNTY, NEW JERSEY
 FEBRUARY 1, 1981

SHEET 2 OF 2

NOV 30 1981
 DEC 29 1981

CONDIT FAMILY COOK HOUSE
 366 SOUTH LIVINGSTON AVENUE
 TOWNSHIP OF LIVINGSTON
 ESSEX COUNTY, NEW JERSEY

FIRST FLOOR PLAN

18' 3 3/4" SOUTHWEST ELEVATION

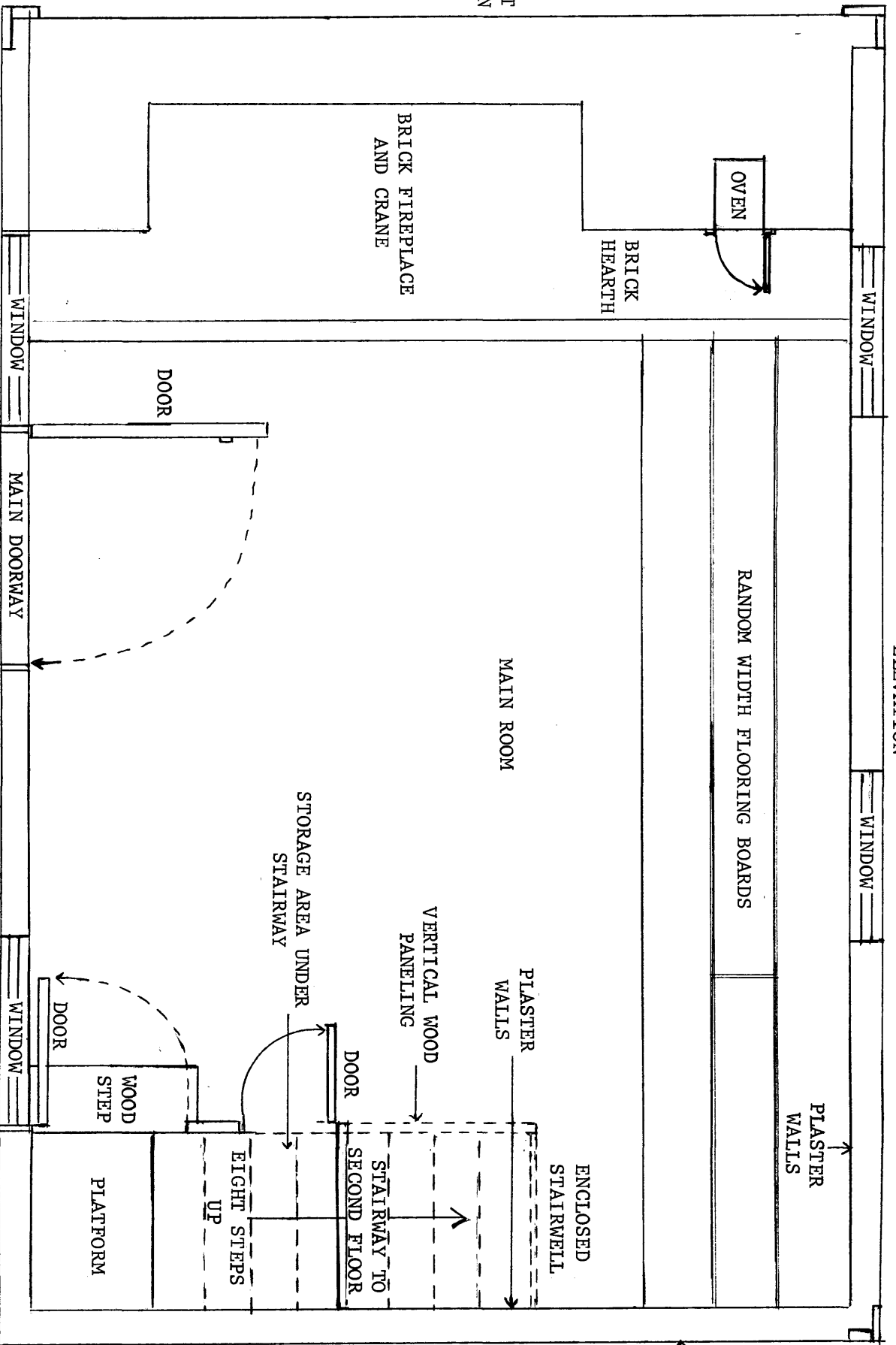

SOUTHEAST ELEVATION

12' 3"

DRAWN BY: RUSSELL A. JONES, JR.
ASSISTANT TO THE MANAGER
TOWNSHIP OF LIVINGSTON
ESSEX COUNTY, NEW JERSEY

SHEET 1 OF 2

NORTHEAST ELEVATION

DEC 20 1981

NOV 30 1981

Ward Fence Abuse
CONDIT FAMILY COOK HOUSE
366 SOUTH LIVINGSTON AVENUE
TOWNSHIP OF LIVINGSTON
ESSEX COUNTY, NEW JERSEY

CLAPBOARD SIDING

NORTHWEST ELEVATION

NORTHEAST
ELEVATION

24' 6"

WALL BELOW

OPEN TO BARN EXHIBIT
AREA BELOW

WOOD CEILING
RAFTERS

EXPOSED WOOD
FRAMING

NORTHWEST
ELEVATION

20' 3/4"

WOOD SHINGLES

5' 8 1/2"

7' 7/4"

WIDE WOOD BOARDS

LOFT AREA

OPENING

ROOF OVER STORAGE
ROOM

19' 3/4" SOUTHWEST
ELEVATION

EXTERIOR
WALL

STORAGE
AREA

WINDOW

CLAPBOARD
SIDING

WALL

BUTTERY
CEILING

CEILING RAFTERS FOR
BUTTERY CEILING

MUSEUM
ROOM

SOUTHEAST
ELEVATION

EXTERIOR
WALL

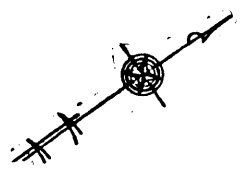

DRAWN BY: RUSSELL A. JONES, JR.
ASSISTANT TO THE MANAGER
TOWNSHIP OF LIVINGSTON
ESSEX COUNTY, NEW JERSEY
FEBRUARY 17, 1981

SECOND FLOOR PLAN
(LOFT AREA)

Ward/Force House

NOV 3 0 1981

DEC 29 1981

THOMAS FORCE HOUSE
366 SOUTH LIVINGSTON AVENUE
TOWNSHIP OF LIVINGSTON
ESSEX COUNTY, NEW JERSEY

SHEET 2 OF 2

DRAWN BY: RUSSELL A. JONES, JR.
 ASSISTANT TO THE MANAGER
 TOWNSHIP OF LIVINGSTON
 ESSEX COUNTY, NEW JERSEY
 FEBRUARY 17, 1981

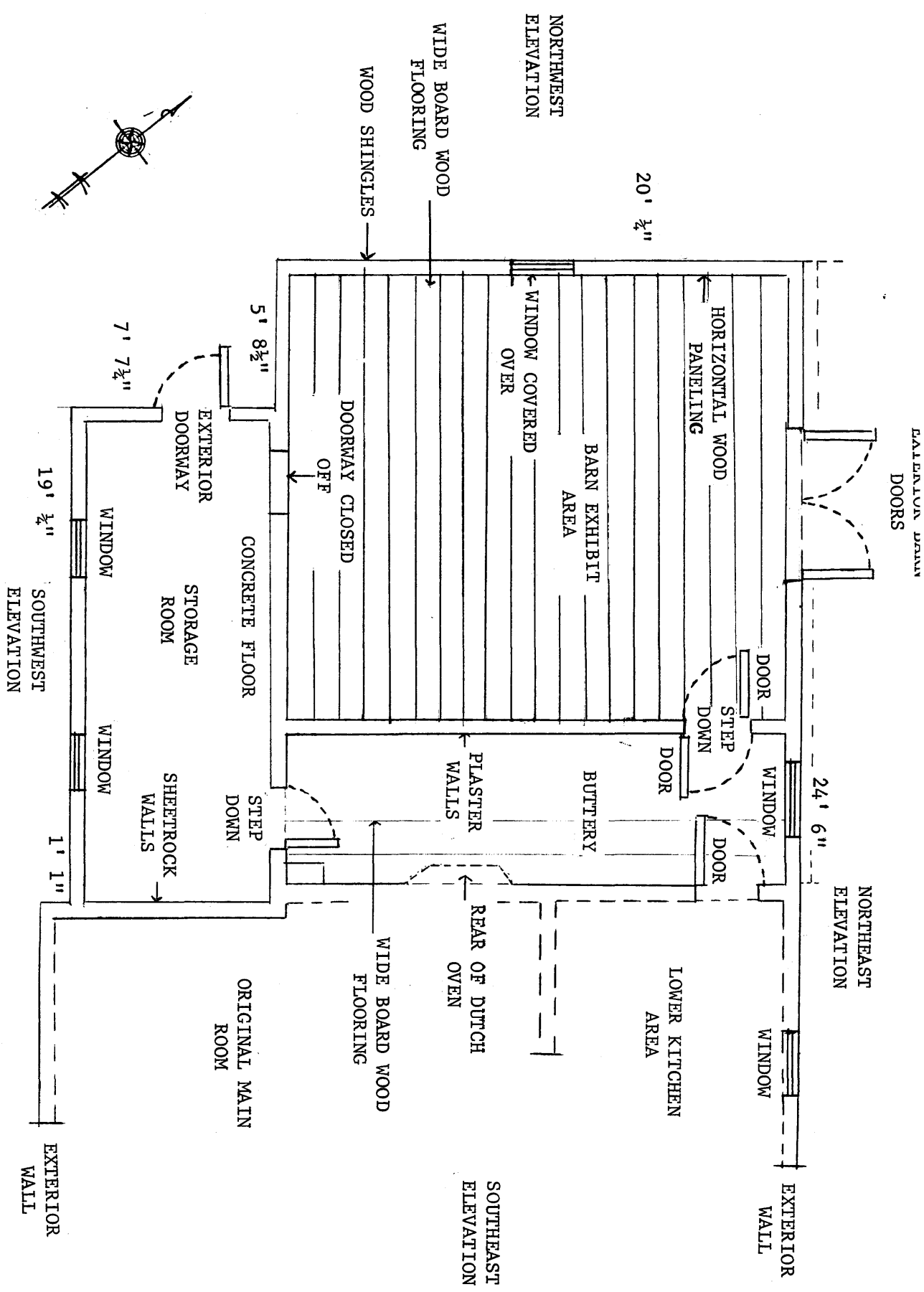

FIRST FLOOR PLAN

DEC 29 1981
 NOV 30 1981

Ward/Force House

THOMAS FORCE HOUSE
 366 SOUTH LIVINGSTON AVENUE
 TOWNSHIP OF LIVINGSTON
 ESSEX COUNTY, NEW JERSEY