

United States Department of the Interior
National Park Service

For NPS use only

National Register of Historic Places
Inventory—Nomination Form

received NOV 2 1983

date entered

See instructions in *How to Complete National Register Forms*
Type all entries—complete applicable sections

1. Name

historic St. Andrew's Protestant Episcopal Church.

and/or common " "

2. Location

street & number 1231 Washington ^{Bldg.} ~~Boulevard~~ N/A not for publication

city, town Stamford N/A vicinity of

state Connecticut code 09 county Fairfield code 001

3. Classification

Category	Ownership	Status	Present Use
<input type="checkbox"/> district	<input type="checkbox"/> public	<input checked="" type="checkbox"/> occupied	<input type="checkbox"/> agriculture
<input checked="" type="checkbox"/> building(s)	<input checked="" type="checkbox"/> private	<input type="checkbox"/> unoccupied	<input type="checkbox"/> commercial
<input type="checkbox"/> structure	<input type="checkbox"/> both	<input type="checkbox"/> work in progress	<input type="checkbox"/> educational
<input type="checkbox"/> site	Public Acquisition	Accessible	<input type="checkbox"/> entertainment
<input type="checkbox"/> object	<input type="checkbox"/> in process	<input checked="" type="checkbox"/> yes: restricted	<input type="checkbox"/> government
	<input type="checkbox"/> being considered	<input type="checkbox"/> yes: unrestricted	<input type="checkbox"/> industrial
	N/A	<input type="checkbox"/> no	<input type="checkbox"/> military
			<input type="checkbox"/> museum
			<input type="checkbox"/> park
			<input type="checkbox"/> private residence
			<input checked="" type="checkbox"/> religious
			<input type="checkbox"/> scientific
			<input type="checkbox"/> transportation
			<input type="checkbox"/> other:

4. Owner of Property

name Parish of St. Andrew's P.E. Church & Parish of St. John's P.E. Church

street & number 1231 Washington Boulevard 628 Main St., Stamford

city, town Stamford N/A vicinity of state Connecticut

5. Location of Legal Description

courthouse, registry of deeds, etc. Stamford Land Records, Municipal Building

street & number 175 Atlantic Street

city, town Stamford state Connecticut

6. Representation in Existing Surveys

title State Register of Historic Places has this property been determined eligible? yes no

date 1983 federal state county local

depository for survey records Connecticut Historical Commission, 59 South Prospect Street

city, town Hartford state Connecticut

7. Description

Condition		Check one	Check one
<input type="checkbox"/> excellent	<input type="checkbox"/> deteriorated	<input type="checkbox"/> unaltered	<input checked="" type="checkbox"/> original site
<input checked="" type="checkbox"/> good	<input type="checkbox"/> ruins	<input checked="" type="checkbox"/> altered	<input type="checkbox"/> moved
<input type="checkbox"/> fair	<input type="checkbox"/> unexposed		date _____

Describe the present and original (if known) physical appearance

The ecclesiastical complex of St. Andrew's Protestant Episcopal Church includes three mid-to-late nineteenth century masonry structures and is located on the east side of Washington Boulevard, slightly to the northwest of the central business district. Occupying a park-like setting of over two acres, the complex extends east to Franklin Street. The Victorian Gothic church (1860; with major alterations in the 1880s), rectory (1872) and parish hall (1880) provide a strong contrast to the encircling modern commercial buildings.

The irregularly shaped church property, part of the original glebe of St. John's Church, the mother church of St. Andrew's, fronts on Washington Boulevard extending 262 feet along the boulevard, 363 feet along Franklin Street and approximately 465 feet deep. To the south the church complex is bounded by the solid wall of Bloomingdale's department store and Bloomingdale's three-level parking garage faces the church complex across Washington Boulevard. Another parking lot borders the grounds to the north while the last remnants of a nineteenth century neighborhood, including a row of small brick town-houses, faces the church cemetery (photograph #3) along Franklin Street.

The church property, like the surrounding area, is almost flat, and little higher than the Rippowan River which runs behind Bloomingdale's parking garage. The church's broad front lawn is distinguished by large maples, while a purple beech and white birches complement the color of the stonework of the church. Tall Norway spruces form a fitting backdrop for the rectory while the cemetery, located between the rear of the church and Franklin Street, is shaded by a grove of white ash trees. The Victorian row houses opposite the church property on Franklin Street give some sense of the character of the neighborhood when the complex was being constructed.

The church is a random ashlar structure consisting of a central core erected in 1860 and designed by the New York architectural firm of Browne and Rogers. The design of Browne and Rogers is much obscured by later additions and the church as it now stands is more the product of Henry Hudson Holly than the original architects. Measuring 28 feet by 58 feet, the original section has pointed arch, stained glass windows on the north and south elevations, as well as small triangular dormers projecting from the roof. The south elevation is distinguished by the original side entrance with its relieving arch of cut-stone voussoirs set above the stone lintel of the doorway. Located at the east end of the building, the chancel is comprised of the choir and sanctuary and dates from the extensive alterations undertaken in the early 1880s after the designs of architect Henry Hudson Holly (plate 2). The sanctuary occupies the gabled addition which replaced the original apsidal chancel, while the choir takes up 14 feet of the original nave. The loss of this area was more than compensated for by the simultaneous construction of the transept, located at the front of the nave, and measuring 22 feet by 32 feet. The transept has north and south gabled projections with paired, arched stained-glass windows surmounted by central bull's-eye windows (photograph #6). Attached to the westerly elevation is the tower, built in 1930. It features a circular stained glass window over the pointed arch entrance doorway, and a flat-roofed, louvered belfry (photograph #6).

Projecting to the south of the choir is the chapel, measuring 22 square feet, and originally built in 1888 as an organ transept. The upper portion of its first floor is lit by a row of windows set in Gothic trefoil arches. The steeply pitched gable of the chapel is covered by flush boards set in a herringbone pattern, while circular bosses enliven the flat bargeboards at the eaves (photograph #2). The entire roof is covered by gray

United States Department of the Interior
National Park Service

National Register of Historic Places
Inventory—Nomination Form

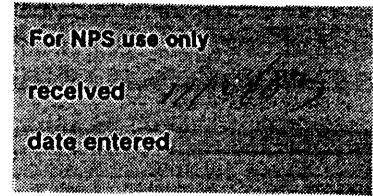

Continuation sheet St. Andrew's Protestant Episcopal Church, Stamford, Ct Item number #7

Page 1

slate shingles, and rests on rafters with exposed curvilinear ends.

The interior of the church is distinguished by an elaborate wrought-iron choir screen running the width of the chancel, along the aisle which connects the parish hall, choir, and chapel. It was designed by Henry J. Hardenburgh, the noted New York architect, in 1909. Resting on a carved stone parapet, it forms an arch over the entrance to the choir which rises several steps above the aisle. Located to the right of the chancel is a large pipe organ. The sanctuary is framed by a massive, pointed arch bordered by painted foliate designs. The intricately carved altar was also designed by Hardenburgh, and features a reredos with four carved angels flanking the stained glass triple window depicting the Ascension of Christ. Above the altar, the coffered sanctuary ceiling is decorated with applied ogee arches. Tile mosaics cover the floor of the chancel, as well as the aisles of the nave and transept.

Noteworthy stained-glass windows also light the nave and transept. The six transept windows were made in London and depict the Six Works of Mercy. The interior walls are distinguished by panelled wainscoting and chamfered pilasters rising to meet the cornice with its frieze of quatrefoil cut-outs. The ceiling is distinguished by the exposed chamfered beams and curved braces of the hammerbeam trusses. These beams are decorated by a vine pattern painted on the underside of the roof boards. Interior furnishings at this end of the church include a baptismal font similar in design to the altar, a lectern fashioned in the shape of an eagle, and several varieties of hanging lanterns.

The parish hall (photograph #5) is attached to the north end of the church and was designed by H. Hudson Holly in 1880 at the time he undertook the major alterations to the church. The hall is "T" shaped in plan, and constructed of random ashlar stone which matches that of the church and rectory. The parish hall's gables are covered with patterned wood shingles (photograph #6). The transverse portion of the building contains the parish hall, itself, which measures 26 feet by 40 feet and is surmounted by a steeply gabled roof with hipped lower slopes. The east and west elevations are lit by a pair of triple windows with stained-glass transoms crowned by stone segmental arches which are carried up to the horizontal lines of the eaves. The gables are covered by bands of shingles, and lit by a pair of leaded windows near the peak. A compatible kitchen and classroom addition, built in 1965, is attached to the north elevation (photograph #5).

The section which connects the great hall to the church consists of a vestry and parish office. Its most notable feature is the row of fine, stained-glass windows which extends along a portion of the west elevation. Similar in design to these windows are the triple window of the vestry, and the double windows flanking the off-center ashlar chimney of the parish office.

The interior ornament of the parish hall consists largely of panelled wainscoting and molded door trim with bull's-eye corner blocks. The great hall at the northern end has a distinctly medieval feeling, with chamfered pilasters rising above the wainscoting to meet the slightly arched braces supporting the rafters of the hipped portion of the roof. The south side of the hall also has its original sliding doors.

The rectory, located on the grounds to the south of the church, displays all of the high-Victorian Gothic detail of the period not so readily evident in the more restrained ex-

United States Department of the Interior
National Park Service

National Register of Historic Places
Inventory—Nomination Form

St. Andrew's P.E. Church,

Continuation sheet Stamford, CT

Item number #7

Page 2

For NPS use only

received

date entered

terior of the church and parish hall (photograph #7). The main section measures approximately 38 feet by 44 feet, while the high service wing is 17 feet by 29 feet. Two and a half stories tall the rectory combines random ashlar, dressed stone, brick, slate, and wood in a picturesque assemblage of jerkinhead gables, cut-work porches, polygonal bays, and overall polychromatic effect. The "L" shaped front porch rests on chamfered posts, and wraps around the southwest corner of the building. Its front entrance is framed by a trefoil arch pierced by geometric cutouts, and surmounted by a projecting gable carried on large triangular brackets. Crowning the peak is a wooden scrollwork finial. Decorative wooden cutwork also enhances the brackets of the porch as well as its fringed valance. The front door has sidelights and is topped by a pointed-arch transom. Four full-length windows face out onto the porch. The small rear porch is presently enclosed, but still displays its original cutwork railing, triangular brackets, and scalloped valance. The rear door is also surmounted by a pointed arch shaped transom.

On the whole, the distinctive fenestration of the building provides an effective counterpoint to the random ashlar walls. The single windows are one over one, have pointed arches, and are surrounded by a keyed pattern of bricks alternating with dressed stone blocks. The triple windows are similarly treated, but have stone lintels, some with relieving arches above them. Distinguishing the south elevation is a polygonal bay window surmounted by a similar, but smaller bay with a skirt of slate shingles. Another polygonal bay projects from the north elevation.

All sides of the house feature full-height, jerkinhead gables supported on bowed braces, which, in turn, are carried on paired, triangular brackets at the base of each gable.

The eaves reveal curved rafter ends, while the steep slate roof shows a pattern of square cut shingles alternating with hexagonal ones.

The mansarded southwest corner displays a small, gabled dormer with curve-ended brackets supporting its eaves. Rising above the roofline are two high, corbeled brick chimneys, one paired and one single. A smaller chimney rises from the service wing.

Like the exterior, the interior of the rectory retains most of its original details. The front door leads into a wide central hall that terminates at the service wing. A single-flight stairway is located on the left side of the hall and features a carved octagonal newel post and a handsome molded handrail that continues (after a 180° curve) along the second floor landing above. Lincrusta wall paper, of foliate design, covers the walls of the stairwell and hall. On the right of the hall are a music room and a library. To the left of the hall are a living room and a dining room. The living room and music room are entered through segmentally arched openings. All of the rooms and the hall have molded cornices and trim, as well as decorative plaster ceiling rosettes of varying floral and foliate designs.

The living room has a white marble fireplace surround with a round-corner opening and a cartouche. Above it is a large, gilded oval mirror, probably original to the house. The dining room has a similar fireplace surround of a purplish-brown color. Distinguishing the library are panelled wainscot built-in cabinets, interior, louvered shutters on the narrow side windows, and a distinctive carved wooden mantelpiece with a segmental arch opening of the polygonal bay, a motif which is repeated in the master bedroom above, and in the dining room.

**United States Department of the Interior
National Park Service**

**National Register of Historic Places
Inventory—Nomination Form**

For NPS use only
received
date entered

St. Andrew's P.E. Church,
Stamford, CT

Item number #7

Page 3

Continuation sheet

The landing at the top of the main stairway, leads back into the service wing, while three more steps toward the front of the house lead to the main second story hallway that provides access to four bedrooms. The master (south) bedroom has a molded chair rail and a gray marble fireplace surround with a round-arched opening covered by a wrought-iron screen. The north end of the hallway is framed all up top by wide console brackets. The bedroom to the right has a fireplace surround similar to that of the dining room.

The service wing includes a kitchen and pantries on the first floor, a narrow stairway with turned spindles, and two bathrooms and a small bedroom on the second floor. The attic story contains a five-room apartment for the caretaker which was not accessible.

The church cemetery, located at the rear of the church, and fronting on Franklin Street, predates the church proper. Ten graves were moved from West Park Cemetery on Main Street in 1801 and the cemetery now contains approximately 700 burials. The plot is 124 feet by 164 feet and is defined by stone walls. Many prominent burials are located in the cemetery at St. Andrew's including Isaac Quintard, one of the pioneer settlers of Stamford, Rev. Ebenezer Dibble, Rev. John Bishop, John Day Ferguson, one of the founders of St. Andrew's Church, and William H. Holly, an ancestor of the church's architect, H.H. Holly.

8. Significance

Period	Areas of Significance—Check and justify below			
___ prehistoric	___ archeology-prehistoric	___ community planning	___ landscape architecture	___ religion
___ 1400–1499	___ archeology-historic	___ conservation	___ law	___ science
___ 1500–1599	___ agriculture	___ economics	___ literature	___ sculpture
___ 1600–1699	xxx architecture	___ education	___ military	___ social/
___ 1700–1799	___ art	___ engineering	___ music	___ humanitarian
xx 1800–1899	___ commerce	___ exploration/settlement	___ philosophy	___ theater
___ 1900–	___ communications	___ industry	___ politics/government	___ transportation
		___ invention		___ other (specify)

Specific dates 1860, 1872; c. 1880 **Builder/Architect** Browne & Rogers; H.H. Holly

Statement of Significance (in one paragraph)

One of Stamford's finest examples of the Victorian Gothic style, the St. Andrew's Church, parish hall and rectory complex was largely the product of the designs of Henry Hudson Holly, a nationally-known architect and author of the last half of the nineteenth century (criterion C). The complex possesses significance not only because of its fine proportions, handsome details and architectural integrity, but because it is a rare survival of Holly's work in Stamford. The architecture of the complex, bearing Holly's stamp, reflects the social importance and wealth of the Episcopal Church in Stamford during the latter half of the nineteenth century (criterion A).

St. Andrew's Church was begun as a mission of St. John's Protestant Episcopal Church, which was founded in 1742 and was the mother church of all the Episcopal churches in Stamford, Greenwich, Darien and New Canaan. St. Andrew's was the first outgrowth of the Missionary and Benevolent Society of St. John's Parish. This missionary work was promoted and carried out through the influence of John Ferguson, a prominent local citizen. Ferguson was a lawyer with a practice in New York City; he served not only on the local school district committee, but also as a representative in the state legislature from Stamford. St. Andrew's was the first free church the diocese under the administration of one rector. The parish was not incorporated until June 12, 1865, but by this date the first church building had already been in existence for some years. On May 14, 1860, the cornerstone for the new church, designed by the New York City firm of Browne and Rogers, was laid. Construction proceeded briskly on the simple stone chapel and the church was consecrated on May 8th of the following year. By 1865 fifty-four families were members of the new church.¹

The church complex began its evolution from a small chapel to an impressive group of High Victorian buildings in the early 1870s. A wooden bell tower was constructed off-center on the front elevation in 1870.² Embellishments to the church proper were slowed when in early in 1872 the construction of the rectory was begun.³ On June 13th of the same year the rectory cornerstone was formally laid and by October 18th of the following year the building was completed.⁴ The design of the rectory is attributed to Henry Hudson Holly, an architect with Stamford antecedents and a national reputation.⁵ Holly's contract was the architect's first documented contact with St. Andrew's. The glorious and richly detailed rectory must have pleased the congregation, for its construction marked the beginning of a protracted association between the architect and the church.

Henry Hudson Holly (1834–1892) was a well-known author on nineteenth century American architecture, furniture and decoration. Although Holly, the son of William Welles Holly, was a native of New York City, his ancestors had been among the first to settle in what is now Stamford.⁶

In 1854 Holly began the study of architecture in the office of Gervase Wheeler. Wheeler, an Englishman, was relatively new to New York when Holly joined him, but the older man had already achieved recognition in the United States through the publication in 1851 of his book Rural Homes; or, Sketches of houses suited to American country life. Holly completed his architectural studies in England in 1856. Upon his return to the United States

9. Major Bibliographical References

See continuation sheet

10. Geographical Data

Acreage of nominated property approx. 2.5 acres

Quadrangle name Stamford

Quadrangle scale 1:24,000

UTM References

A	1 8	6 2 2 5 0 0	4 5 4 5 9 2 0	B			
	Zone	Easting	Northing		Zone	Easting	Northing
C				D			
E				F			
G				H			

Verbal boundary description and justification

See continuation sheet

List all states and counties for properties overlapping state or county boundaries

state	N/A	code	county	code
state	N/A	code	county	code

11. Form Prepared By

name/title Kate Ohno, Preservation Consultant - Renee Kahn & Associates
Preservation Development Group, Stamford

organization Connecticut State Historical Commission Edited by John Herzan, National Register Coordinator
date December 17, 1982

street & number 59 South Prospect Street telephone (203) 566-3005

city or town Hartford state Connecticut

12. State Historic Preservation Officer Certification

The evaluated significance of this property within the state is:

national state local

As the designated State Historic Preservation Officer for the National Historic Preservation Act of 1966 (Public Law 89-665), I hereby nominate this property for inclusion in the National Register and certify that it has been evaluated according to the criteria and procedures set forth by the National Park Service.

State Historic Preservation Officer signature

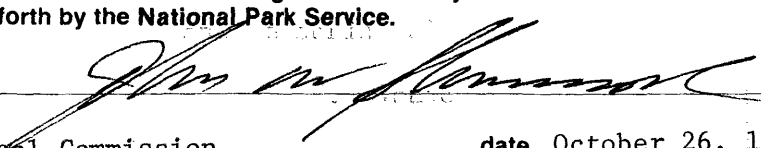

title Director, Connecticut Historical Commission

date October 26, 1983

For NPS use only

I hereby certify that this property is included in the National Register

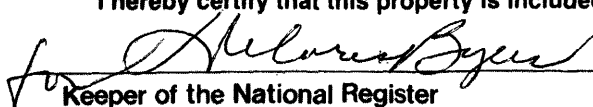

Entered in the
National Register

date 12/6/83

Keeper of the National Register

Attest:

date

Chief of Registration

United States Department of the Interior
National Park Service

National Register of Historic Places
Inventory—Nomination Form

For NPS use only
received <i>11/2/83</i>
date entered

St. Andrew's P.E.Church

Continuation sheet Stamford, CT

Item number #8

Page 1

in 1857 Holly set up his office in New York, but chose to live in Stamford. Holly was elected to the newly formed American Institute of Architects in 1858 and probably held the distinction of having been the institute's youngest member at that time. Preparation for Holly's first book, which was to enlarge his practice and publicize his work, probably began during this period. Country Seats, published in 1863, was to reflect one of the two main thrusts in Holly's practice, his interest in residential architecture.⁷

Unlike his contemporaries Frank Furness and H.H. Richardson, who are better known to students of Victorian architecture today, Holly proposed designs that were of the latest style without being avant garde. Although Holly was interested in technical innovations, his books were mainly written for laymen. His writing style and well as the buildings he proposed were designed for the popular market and succeeded admirably in this objective.⁸

Holly's second book, Church Architecture, was published in 1871.⁹ Holly's interest in ecclesiastical architecture as well as his reputation in the New York-Stamford area and his books probably all contributed to St. Andrew's choice of architect of the rectory.

Holly's involvement in the upgrading of the church property continued through the early 1880s. He designed the parish hall which was constructed in 1880 on the north side of the sanctuary.¹⁰ The random ashlar walls of the parish hall complemented those of the church, but the shingled gables foreshadowed the popularity of the Queen Anne style. The parish hall was connected to the sanctuary by means of a cloister off of which open the church offices and vestry on the east side of the corridor.

In the same year the appearance of the church was updated and the sanctuary was enlarged by the addition of a transept to the front of the sanctuary. The transept was designed by Holly and was erected through the generosity of Mrs. J.W. Leeds, a parishioner who gave the transept as a memorial to her husband and three sons. The transept measured 21 feet by 36 feet and succeeded not only in increasing the usable space within the building, but also in enriching the appearance of the church. During the construction new pews were installed and six memorial stained-glass windows, produced in London and illustrating the Six Works of Mercy, were put in place. The enhancement of the church continued in 1881 and in that year a new 18 feet by 22 feet chancel was completed at the rear of the sanctuary. This chancel replaced a smaller apsidal chancel. Holly was also in charge of the new chancel construction and the contractors included N.L. Townds, C.W. Knapp and the firm of Ballard and Weed. Mrs. Charles S. Smith of New York gave the stained-glass triptich windows in the new chancel depicting the Ascension of the Lord as a memorial to her parents. These windows, also of English glass, were installed in a prominent position behind the altar. With the bulk of the major construction work completed, the church was reopened for worship on May 25, 1881. However the upgrading of the church continued through the end of the century. The interior of the church was altered through the construction of new choir stalls. The choir was installed on the east end of the nave in front of the 1881 chancel. In 1888 a great new work was put in hand; the construction of a new organ transept just south of the choir. Holly was probably also the author of the design of this addition, and it blends well with the rest of the complex. The organ transept was the last major addition to the church until 1930. The embellishment of the interior of the sanctuary continued with the installation

**United States Department of the Interior
National Park Service**

**National Register of Historic Places
Inventory—Nomination Form**

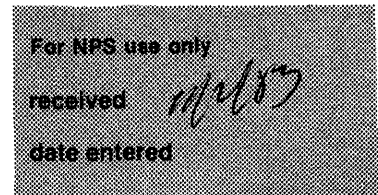

Continuation sheet St. Andrew's P.E. Church
Stamford, CT

Item number #8

Page 2

of a stained-glass window over the front entrance, a memorial to the same Mrs. Leeds who paid for the erection of the transept. A new organ given by Mrs. W.H. Tallmadge was housed in the new organ transept by 1889 and in 1894 the laying of a new tile floor was begun in the choir. The following year similar pavement was installed in the nave. Major items of church furniture were donated during the last decade of the century by prominent members of the church, and Holly's renovation was complete. Where in 1870 had stood a simple rectangular stone chapel now stood a large richly ornamented and asymmetrically massed church complemented by the cloistered parish hall and High Victorian Gothic rectory.¹¹

In the early twentieth century another nationally known architect became associated with St. Andrew's. Henry J. Hardenburgh (1847-1918) is best known for his monumental eclectic undertakings such as the Dakota Apartments (1884) and the Plaza Hotel (1907), both in New York City. In 1889 he designed the altar for St. Andrew's and in 1909 the iron reredos.¹² Hardenburgh also designed the interior of the Union Bank and Trust Company in Stamford.

The twentieth century saw the addition of new enrichments to the church. In 1930 the old bell tower of 1870 was removed and a stone replacement built directly over the front entrance. The construction was the result of a bequest from Elizabeth Holly Hudson. The last major addition made to the church was that of a kitchen and classroom wing added to the north side of the parish hall in 1965. The addition was designed to be consistent in size, style and proportion with the church complex and does not detract from the architectural significance of the site.¹³

Thus St. Andrew's Church grew from a small and modest missionary chapel to the handsome Victorian Gothic complex that today is an historic and architectural landmark set on a verdant lawn in the midst of a bustling downtown commercial setting. In this complex we can perceive the striving of Victorian residents of Stamford to recapture the great days of church architecture. A book published just a few years after the completion of the organ transept lauds the parish hall and describes it as being built "in the advanced Gothic style of architecture, with thirteenth century feeling."¹⁴ Today the church complex retains its importance as a religious and civic center and as one of the rare intact survivals of a Victorian church complex designed by one of the nation's most prominent Victorian architects.

**United States Department of the Interior
National Park Service**

**National Register of Historic Places
Inventory—Nomination Form**

For NPS use only

received

date entered

Continuation sheet St. Andrew's P.E. Church,
Stamford, CT

Item number #9

Page 1

Bibliography

- Gillespie, Edward T.W., Picturesque Stamford.
Stamford: Gillespie Bros; 1892, 162-164.
- Kahn, Renee, "Henry Hudson Holly," unpublished short biography
in the files of the Preservation Development
Group, Stamford, CT.
- Tomlan, Michael, ed. Country Seats and Modern Dwellings Two
Victorian Domestic Architectural Stylebooks
American Life Foundation, 1977.
- Zeranski, Joseph, Abstracts of the records of St. Andrew's
Church prepared January 11, 1980, unpublished
manuscript in the files of the Preservation
Development Group, Stamford.

**United States Department of the Interior
National Park Service**

**National Register of Historic Places
Inventory—Nomination Form**

For NPS use only
received 11/2/83
date entered

Continuation sheet St. Andrew's P.E. Church,
Stamford, CT

Item number #10

Page 1

The St. Andrew's Church complex is bounded on the north by a surface parking lot, on the east by Franklin Street, on the south by Bloomingdale's department store and on the west by Washington Boulevard. The surface parking lot presents an obvious visual contrast to the Victorian complexities of the church, parish hall and rectory and is unsuitable for inclusion in the district. The last remnants of the Victorian neighborhood in the form of brick townhouses, which once surrounded the church now stands on the east side of Franklin Street, but has not been included in the nomination because although it is close to the church complex it has no historical link to it. Franklin Street thus forms the logical boundary on the east. To the south and west stand Bloomingdale's department store incompatible in size, materials, style and age with the church complex and far removed from the complex in function. Bloomingdale's parking garage stands on the westside of Washington Boulevard, making the street a logical boundary for the property.

The dimensions of the nominated area may be found in Volume 1176, page 608, (Parish of St. Andrew's Protestant Episcopal Church) and in Volume 915, page 421 and Volume 1402, page 608, (Parish of St. John's Protestant Episcopal Church).

CEMETERY

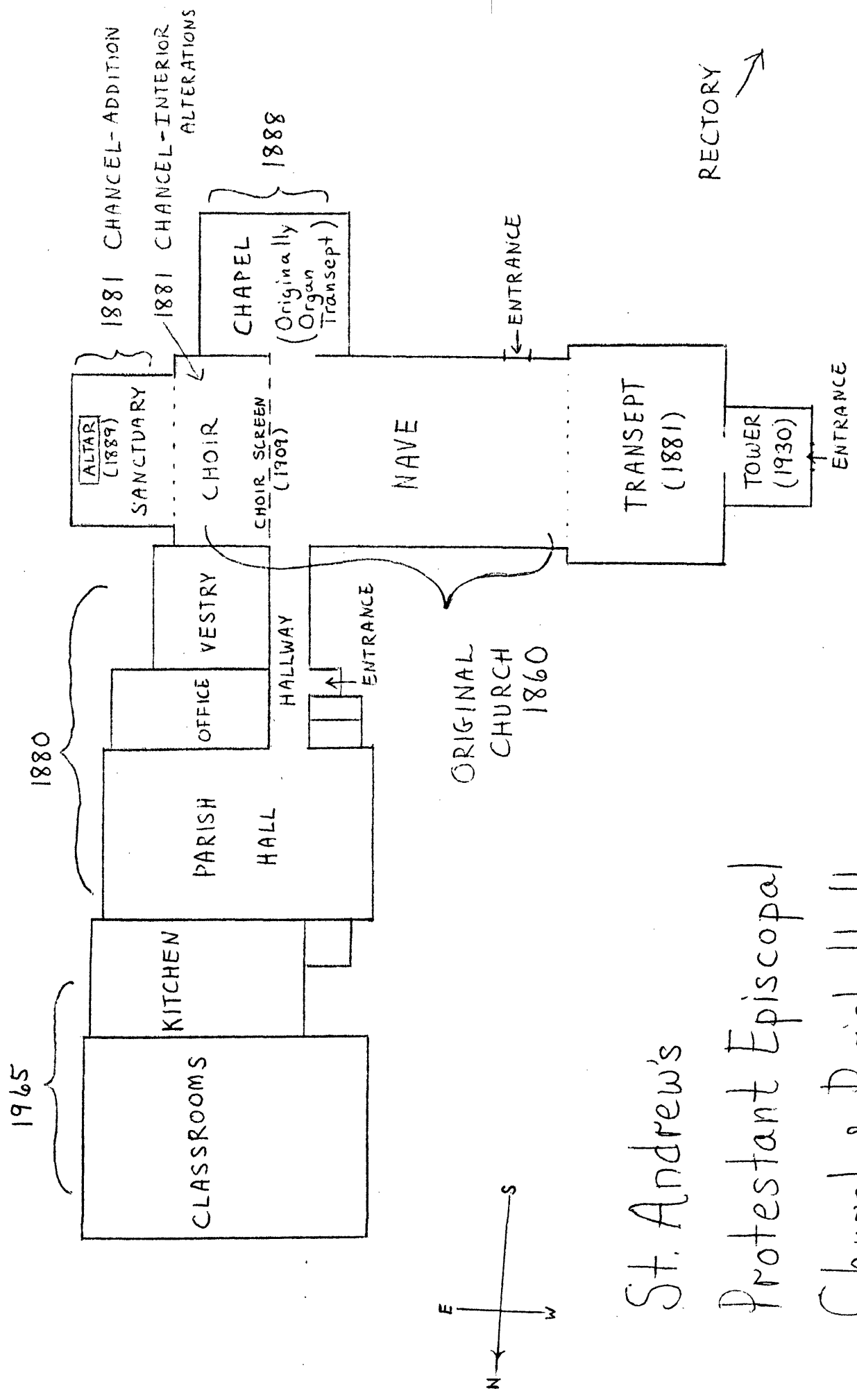

St. Andrew's
 Protestant Episcopal
 Church & Parish Hall

0 5 10 15 20 25
 SCALE 1 inch = 20 ft.

United States Department of the Interior
National Park Service
National Register of Historic Places
Inventory—Nomination Form

For NPS use only
received 11/2/83
date entered

Continuation sheet St. Andrew's P.E. Church, Item number #8 Page 3
Stamford CT

End Notes

- ¹Edward T.W. Gillespie, Picturesque Stamford (Stamford: Gillespie Bros. 1892), pp. 162-164.
- ²Records of St. Andrew's Church, abstracted by Joseph Zeranski 1/11/1980. (Abstract in the files of the Preservation Development Group, Stamford).
- ³Ibid.
- ⁴Ibid.
- ⁵Renee Kahn, "Henry Hudson Holly," (in the files of the Preservation Development Group, Stamford). See also Michael Tomlan, ed., Country Seats and Modern Dwellings Two Victorian Domestic Architectural Stylebooks by Henry Hudson Holly (Watkins Glen, New York: American Life Foundation, 1977).
- ⁶Tomlan, Henry Hudson Holly.
- ⁷Ibid.
- ⁸Ibid.
- ⁹Ibid.
- ¹⁰Kahn, "Holly."
- ¹¹Zeranski, Abstracts of St. Andrew's Church Records.
- ¹²Ibid.
- ¹³Ibid.
- ¹⁴Gillespie, Picturesque Stamford, 162.

83-00510

STATE OF CONNECTICUT

CONNECTICUT HISTORICAL COMMISSION

59 South Prospect Street, Hartford, Connecticut 06106
(203) 566-3005

HISTORIC RESOURCES INVENTORY FORM
For Buildings and Structures

FOR OFFICE USE ONLY

TOWN NO.: SITE NO.:
UTM: 18/6/22/500 / 45/45/950
QUAD:
DISTRICT: S NR: ACTUAL
POTENTIAL

Inventory # 24

IDENTIFICATION

Protestant Episcopal

- 1. BUILDING NAME: Common: St. Andrew's Church Historic: St. Andrew's Church
- 2. TOWN/CITY: Stamford COUNTY: Fairfield
- 3. STREET & NUMBER (and/or location): 1231 Washington Blvd.
- 4. OWNER(S): Parish of St. Andrew's P.E. Church
- 5. USE: Present: Church Historic: Church
- 6. ACCESSIBILITY TO PUBLIC: Exterior visible from public road: yes no

DESCRIPTION

- 7. STYLE OF BUILDING: Victorian Gothic (Gothic Revival, 3/15/87) DATE OF CONSTRUCTION: 1861
- 8. APPROXIMATE DIMENSIONS: 28' x 58'
- 9. ARCHITECT H.H. Holly BUILDER Unknown

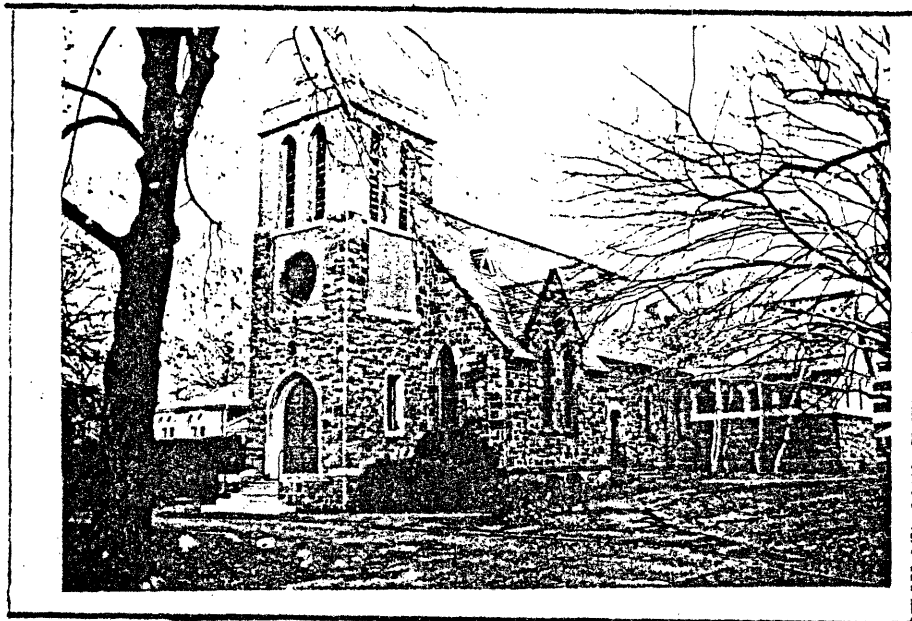

photographer: Steven Hirschberg name: Renee Kahn Associates date: July 77-Mar. 78
 date: July 1977-Mar. 1979 view: W/S organization: Stamford Community Development Program
 negative on file: Stamford Historical Society address: 429 Atlantic Street

10. ADDITIONAL COMMENTS:

See attached sheet.

Subsequent Field Evaluations: (3/15/87) Stucco cement has been applied to the upper third of the tower, around the circular facade window, and the panels on the sides, apparently to halt the deterioration of the limestone in these locations.

A modern addition (40' x 48') was added to the north end of the parish hall in 1965. It contains a kitchen and classrooms.

STATE OF CONNECTICUT
CONNECTICUT HISTORICAL COMMISSION
59 South Prospect Street, Hartford, Connecticut 06106
HISTORIC RESOURCES INVENTORY FORM
For Buildings and Structures

FOR OFFICE USE ONLY

TOWN NO.: _____ SITE NO.: _____
UTM: 18 / - / - / - / - / - / - / - / - / -
QUAD: _____
DISTRICT: S NR: ACTUAL
POTENTIAL

CONTINUATION SHEET

1231 Washington Blvd., St. Andrews Church & Parish House

Item number: _____ Date: 4/79

OTHER NOTABLE FEATURES

This small stone parish church, not much larger than a chapel and built of random ashlar granite in ¹⁸⁶¹~~1880~~, has a central tower at the front, a transept behind it and the straight sidewalls of the nave pierced by arched windows. The transept projections have paired arched windows surmounted by central bull's-eye windows. A handsome slate roof (recently applied) has diminutive arched dormer windows, two to a side. The tower was begun a year later, in 1881, and only completed in this century.

A deeper chancel (and a chapel on the south side) was added at a later date at the rear. The church, although quite simple on the exterior, belongs definitively to the Victorian Gothic style of architecture. The chapel at the rear has a wood upper portion with alternating windows and clapboarding set in Gothic trefoil arches.

The Parish House, which adjoins the Church to the rear, is built of similar materials but has gables of wood shingles, as well. It was built in 1881 and triple windows on the west side crowned by trimmed stone segmental arches are carried up to meet the horizontal line of the eaves, above which is a hipped portion of slate surmounted by the shingled gable with paired, leaded windows near the apex. An attractive porch entrance leads into a gallery of early stained glass windows; this entrance connects with the church, entering it just in front of the wood screen.

SIGNIFICANCE

Despite its small size, this Victorian Gothic church is quite imposing, especially as viewed in conjunction with the Parish House and the nearby rectory, all set in a spacious and conspicuous site.

The Parish House has been definitely attributed to H. Hudson Holly, the noted Victorian writer and architect, while we can only suspect that he also designed the church (see article on Holly in the survey introduction).

prepared by
Alan Burnham F.A.I.A.

STATE OF CONNECTICUT
CONNECTICUT HISTORICAL COMMISSION
59 South Prospect Street, Hartford, Connecticut 06106
HISTORIC RESOURCES INVENTORY FORM
For Buildings and Structures

FOR OFFICE USE ONLY			
TOWN NO.:	SITE NO.:		
UTM: 18	/	/	/
QUAD:			
DISTRICT:	S	NR:	ACTUAL POTENTIAL

CONTINUATION SHEET
Item number: _____ Date: _____

1231 Washington Blvd.: St. Andrews Church- Interior c. 1892

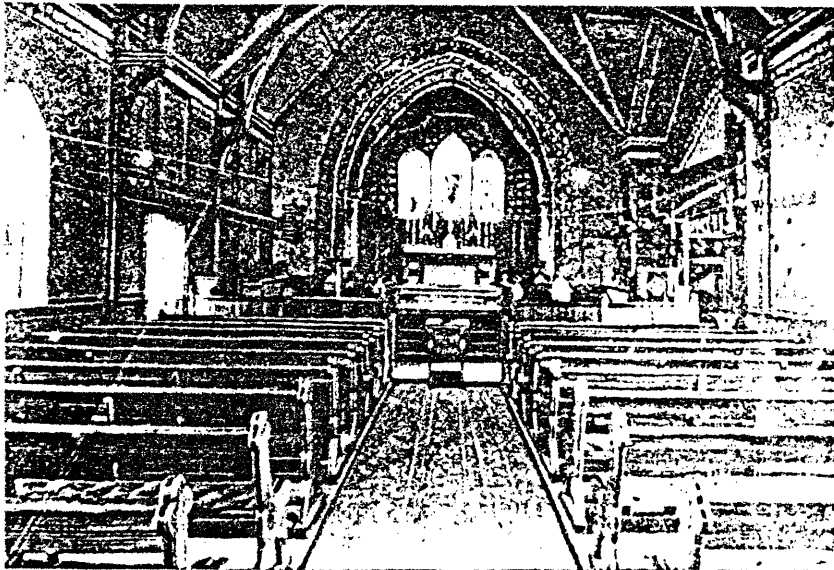

STATE OF CONNECTICUT

CONNECTICUT HISTORICAL COMMISSION

59 South Prospect Street, Hartford, Connecticut 06106
(203) 566-3005

HISTORIC RESOURCES INVENTORY FORM
For Buildings and Structures

FOR OFFICE USE ONLY

TOWN NO.: _____ SITE NO.: _____
UTM: 18/6/22/500 / 45/45/950
QUAD: _____
DISTRICT: 5 NR: ACTUAL
POTENTIAL

Inventory # 25

IDENTIFICATION

- 1. BUILDING NAME: Common: St. Andrew's Parish House Historic: St. Andrew's Parish House
- 2. TOWN/CITY: Stamford COUNTY: Fairfield
- 3. STREET & NUMBER (and/or location): 1231 Washington Blvd.
- 4. OWNER(S): Parish of St. Andrew's P .E. Church
- 5. USE: Present: Parish House Historic: Parish House - Offices
- 6. ACCESSIBILITY TO PUBLIC: Exterior visible from public road: yes no

DESCRIPTION

- 7. STYLE OF BUILDING: Victorian Gothic with Queen Anne elements DATE OF CONSTRUCTION: 1881
- 8. APPROXIMATE DIMENSIONS: 28' x 40'
- 9. ARCHITECT: H.H. Holly BUILDER: Unknown

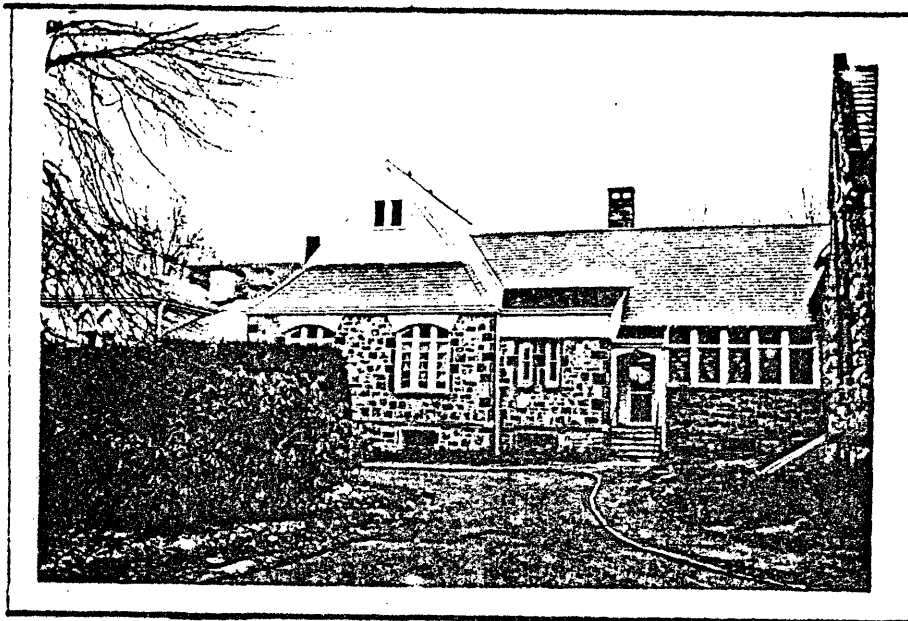

photographer: Steven Hirschberg name: Renee Kahn Associates date: July 77-Mar. 79
 date: July 1977-Mar. 1979 view: W organization: Stamford Community Development Program
 negative on file: Stamford Historical Society address: 429 Atlantic Street

10. ADDITIONAL COMMENTS:

See attached sheet.

STATE OF CONNECTICUT

CONNECTICUT HISTORICAL COMMISSION

59 South Prospect Street, Hartford, Connecticut 06106
(203) 566-3005

HISTORIC RESOURCES INVENTORY FORM
For Buildings and Structures

FOR OFFICE USE ONLY

TOWN NO.: _____ SITE NO.: _____
UTM: 18/6/22/500/45/45/900
QUAD: _____
DISTRICT: 3 NR: ACTUAL
POTENTIAL

Inventory # 26

IDENTIFICATION

- 1. BUILDING NAME: Common: _____ Historic: St. Andrew's Rectory
- 2. TOWN/CITY: Stamford COUNTY: Fairfield
- 3. STREET & NUMBER (and/or location): 1231 Washington Blvd.
- 4. OWNER(S): Parish of St. Andrew's P.E. Church
- 5. USE: Present: Rectory Historic: Rectory
- 6. ACCESSIBILITY TO PUBLIC: Exterior visible from public road: yes no

DESCRIPTION

- 7. STYLE OF BUILDING: Victorian Gothic DATE OF CONSTRUCTION: 1873
- 8. APPROXIMATE DIMENSIONS: 28' x 40'
- 9. ARCHITECT: H.H. Holly BUILDER: Unknown

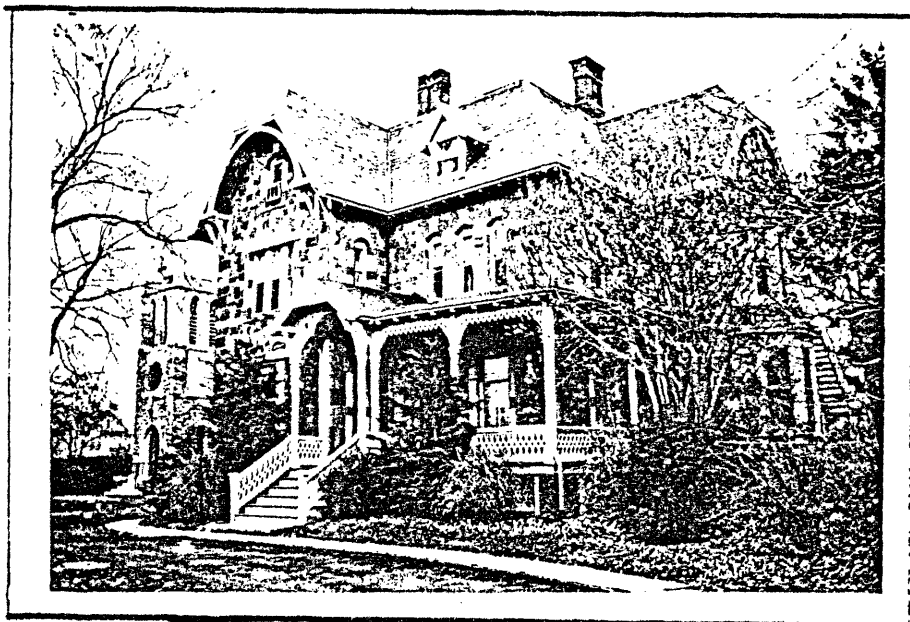

photographer: Steven Hirschberg name: Renee Kahn Associates date: July 77-Mar. 79
 date: July 1977-Mar. 1979 views: W/S organization: Stamford Community Development Program
 negative on file: Stamford Historical Society address: 429 Atlantic Street

10. ADDITIONAL COMMENTS:

See attached sheet.

STATE OF CONNECTICUT

CONNECTICUT HISTORICAL COMMISSION

59 South Prospect Street, Hartford, Connecticut 06106

HISTORIC RESOURCES INVENTORY FORM

For Buildings and Structures

FOR OFFICE USE ONLY

TOWN NO.:

SITE NO.:

UTM: 18

QUAD:

DISTRICT:

S

NR:

ACTUAL

POTENTIAL

CONTINUATION SHEET

1231 Washington Blvd. St. Andrews (Church) Rectory

Item number: _____ Date: _____

4/79

OTHER NOTABLE FEATURES

The Rectory displays all of the high Victorian detail of the period which has been so carefully suppressed in the dignified exteriors of the Church and Parish House. This two-and-one-half story building combines random ashlar, brick and wood quite successfully in a very picturesque assemblage of gables, roof, porches, bays and polychromatic effects. The main gables at the slate roof are jerkin-headed and supported on handsome bowed brackets which, in turn, are carried on paired triangular brackets at each side of the gable.

The windows, where triple, have stone lintels and alternating brick and stone relieving arches above them. The scrollwork at the front porch appears at the gable above the steps and along the top of the porch, which wraps around the right-hand side of the building. The front door has side lights and a transom; a full-length window alongside of it opens onto the porch. High brick chimneys, one paired and one single, surmount the steep slate roof.

SIGNIFICANCE

Designed by the noted architect, H. Hudson Holly, this is a fine example of high Victorian ecclesiastical architecture. Here, a masonry tradition prevails, with wood trim setting it off to advantage. Today, this rectory, set in its spacious site, stands as a reminder of a more opulent and peaceful era.

prepared by
Alan Burnham F.A.I.A.