

**United States Department of the Interior  
National Park Service**

**National Register of Historic Places  
Continuation Sheet**

Section number \_\_\_\_\_ Page \_\_\_\_\_

---

**SUPPLEMENTARY LISTING RECORD**

NRIS Reference Number: 02000375

Date Listed: April 16, 2002

Property Name: Weber, Alois and Annie, House

County: Lee

State: Iowa

none  
Multiple Name

-----  
This property is listed in the National Register of Historic Places in accordance with the attached nomination documentation subject to the following exceptions, exclusions, or amendments, notwithstanding the National Park Service certification included in the nomination documentation.

  
\_\_\_\_\_  
Signature of the Keeper

April 16, 2002  
Date of Action

-----  
Amended Items in Nomination:

Section 8: Statement of Significance "Commerce" is hereby deleted as an area of significance because the narrative statement of significance does adequately justify the importance of Alois Weber under Criterion B.

-----  
The Iowa State Historic Preservation Office was notified of this amendment.

**DISTRIBUTION:**

- National Register property file**
- Nominating Authority (without nomination attachment)**

United States Department of the Interior  
National Park Service

OK 375

NATIONAL REGISTER OF HISTORIC PLACES  
REGISTRATION FORM

This form is for use in nominating or requesting determinations for individual properties and districts. See instructions in How to Complete the National Register of Historic Places Registration Form (National Register Bulletin 16A). Complete each item by marking "x" in the appropriate box or by entering the information requested. If any item does not apply to the property being documented, enter "N/A" for "not applicable." For functions, architectural classification, materials, and areas of significance, enter only categories and subcategories from the instructions. Place additional entries and narrative items on continuation sheets (NPS Form 10-900a). Use a typewriter, word processor, or computer, to complete all items.

1. Name of Property

historic name Weber, Alois and Annie, House

other names/site number \_\_\_\_\_

2. Location

street & number 802 Orleans Avenue not for publication n/a  
city or town Keokuk vicinity n/a  
state Iowa code IA county Lee code 111 zip code 52632

3. State/Federal Agency Certification

As the designated authority under the National Historic Preservation Act of 1966, as amended, I hereby certify that this x nomination     request for determination of eligibility meets the documentation standards for registering properties in the National Register of Historic Places and meets the procedural and professional requirements set forth in 36 CFR Part 60. In my opinion, the property x meets     does not meet the National Register Criteria. I recommend that this     property be considered significant     nationally     statewide x locally. (     See continuation sheet for additional comments.)

*Rowell J. Sorko*

Signature of certifying official

February 26, 2002  
Date

**STATE HISTORICAL SOCIETY OF IOWA**

State or Federal agency and bureau

In my opinion, the property     meets     does not meet the National Register criteria. (     See continuation sheet for additional comments.)

Signature of commenting or other official

Date

State or Federal agency and bureau



=====

6. Function or Use

=====

Historic Functions (Enter categories from instructions)

Cat: Domestic Sub: single dwelling

\_\_\_\_\_

\_\_\_\_\_

\_\_\_\_\_

\_\_\_\_\_

\_\_\_\_\_

Current Functions (Enter categories from instructions)

Cat: Domestic Sub: single dwelling

\_\_\_\_\_

\_\_\_\_\_

\_\_\_\_\_

\_\_\_\_\_

\_\_\_\_\_

=====

7. Description

=====

Architectural Classification (Enter categories from instructions)

Late Victorian/Second Empire

\_\_\_\_\_

\_\_\_\_\_

Materials (Enter categories from instructions)

foundation stone and limestone

roof asphalt

walls brick

other wood

\_\_\_\_\_

Narrative Description (Describe the historic and current condition of the property on one or more continuation sheets.)

=====

8. Statement of Significance

=====

Applicable National Register Criteria (Mark "x" in one or more boxes for the criteria qualifying the property for National Register listing)

- A Property is associated with events that have made a significant contribution to the broad patterns of our history.
- B Property is associated with the lives of persons significant in our past.
- C Property embodies the distinctive characteristics of a type, period, or method of construction or represents the work of a master, or possesses high artistic values, or represents a significant and distinguishable entity whose components lack individual distinction.
- D Property has yielded, or is likely to yield information important in prehistory or history.

Criteria Considerations (Mark "X" in all the boxes that apply.)

- A owned by a religious institution or used for religious purposes.
- B removed from its original location.
- C a birthplace or a grave.
- D a cemetery.
- E a reconstructed building, object, or structure.
- F a commemorative property.
- G less than 50 years of age or achieved significance within the past 50 years.

Areas of Significance (Enter categories from instructions)

\_\_\_\_\_ commerce \_\_\_\_\_  
\_\_\_\_\_ architecture \_\_\_\_\_  
\_\_\_\_\_  
\_\_\_\_\_  
\_\_\_\_\_  
\_\_\_\_\_

Period of Significance ca 1873 \_\_\_\_\_  
\_\_\_\_\_  
\_\_\_\_\_

Significant Dates ca 1873  
\_\_\_\_\_  
\_\_\_\_\_

Significant Person (Complete if Criterion B is marked above)

Cultural Affiliation n/a \_\_\_\_\_  
\_\_\_\_\_  
\_\_\_\_\_

Architect/Builder unknown

Narrative Statement of Significance (Explain the significance of the property on one or more continuation sheets.)

9. Major Bibliographical References

(Cite the books, articles, and other sources used in preparing this form on one or more continuation sheets.)

Previous documentation on file (NPS)

preliminary determination of individual listing (36 CFR 67) has been requested.

previously listed in the National Register

previously determined eligible by the National Register

designated a National Historic Landmark

recorded by Historic American Buildings Survey # \_\_\_\_\_

recorded by Historic American Engineering Record # \_\_\_\_\_

Primary Location of Additional Data

State Historic Preservation Office

Other State agency

Federal agency

Local government

University

Other

Name of repository: \_\_\_\_\_

10. Geographical Data

Acreage of Property less than one

UTM References (Place additional UTM references on a continuation sheet)

	Zone	Easting	Northing	Zone	Easting	Northing
1	15	637560	4473480	3	_____	_____
2	_____	_____	_____	4	_____	_____

See continuation sheet.

Verbal Boundary Description (Describe the boundaries of the property on a continuation sheet.)

Boundary Justification (Explain why the boundaries were selected on a continuation sheet.)

=====  
11. Form Prepared By  
=====

name/title \_\_\_\_\_ Deane Berner \_\_\_\_\_  
organization \_\_\_\_\_ n/a \_\_\_\_\_ date July 1, 2001 \_\_\_\_\_  
street & number 802 Orleans Avenue \_\_\_\_\_ telephone (319) 524-5977 \_\_\_\_\_  
city or town \_\_\_\_\_ Keokuk \_\_\_\_\_ state IA \_\_\_\_\_ zip code 52632 \_\_\_\_\_  
=====

Additional Documentation  
=====

Submit the following items with the completed form:

Continuation Sheets

Maps

A USGS map (7.5 or 15 minute series) indicating the property's location.  
A sketch map for historic districts and properties having large acreage  
or numerous resources.

Photographs

Representative black and white photographs of the property.

Additional items (Check with the SHPO or FPO for any additional items)

=====  
Property Owner  
=====

(Complete this item at the request of the SHPO or FPO.)

name \_\_\_\_\_ Kevin and Diane Berner \_\_\_\_\_  
street & number \_\_\_\_\_ 802 Orleans Avenue \_\_\_\_\_ telephone (319) 524-5977 \_\_\_\_\_  
city or town \_\_\_\_\_ Keokuk \_\_\_\_\_ state IA \_\_\_\_\_ zip code 52632 \_\_\_\_\_  
=====

=====  
=

Paperwork Reduction Act Statement: This information is being collected for applications to the National Register of Historic Places to nominate properties for listing or determine eligibility for listing, to list properties, and to amend existing listings. Response to this request is required to obtain a benefit in accordance with the National Historic Preservation Act, as amended (16 U.S.C. 470 et seq.).

Estimated Burden Statement: Public reporting burden for this form is estimated to average 18.1 hours per response including the time for reviewing instructions, gathering and maintaining data, and completing and reviewing the form. Direct comments regarding this burden estimate or any aspect of this form to the Chief, Administrative Services Division, National Park Service, P.O. Box 37127, Washington, DC 20013-7127; and the Office of Management and Budget, Paperwork Reductions Project (1024-0018), Washington, DC 20503.

United States Department of the Interior  
National Park Service

NATIONAL REGISTER OF HISTORIC PLACES  
CONTINUATION SHEET

Section 7 Page 1

Alois and Annie Weber House  
Lee County, Iowa

---

NARRATIVE DESCRIPTION

**Summary Statement**

Located in the Original City of Keokuk, two blocks from the Mississippi River, this circa 1873 Second Empire brick house was built for Alois Weber and his wife Annie. This 4500 square foot home is grand in scale, with its 17 rooms, tall windows, and high ceilings, but it is simply adorned, save the tin ceilings, which likely came from Mr. Weber's own hardware company. The home's one extravagance is its wonderful Queen Anne style wrap-around porch, which softens its otherwise staid exterior.

**Detailed Description**

Exterior

This three story, Second Empire, brick home has an asymmetrical concave mansard roof supported by decorative brackets and punctuated with six dormer windows with segmental pediments. The visible section of the roof originally had slate shingles, which were replaced in the 1970's with black asphalt shingles. The nearly flat top section is tarred. The tall, wooden sash, double-hung windows (many of which still have their original wavy glass and operate with rope/weights) have straight stone sills and lintels. Most of the windows are four-over-four, except for the bays, which consist of four one-over-one windows. The two north-facing windows are floor length. There are also two circular windows, facing west, one located at the top of each landing. The front door is 42 inches by 82 inches (not including the transom) and has bold detailing and beveled glass inserts.

There appear to be two brick additions to the rear of the house done relatively soon after the original house was completed, as the brickwork and brackets are identical. The additions are both two story and each has a slightly lower roof line than the original section. The stone foundation, however, differs. Also, when a section of paneling in the back hall had to be removed for some plumbing to be repaired, an original window frame was visible. There are also built-in shelves in the dining room and living room that appear to be filling in original window and/or door openings.



United States Department of the Interior  
National Park Service

NATIONAL REGISTER OF HISTORIC PLACES  
CONTINUATION SHEET

Section 7 Page 2

Alois and Annie Weber House  
Lee County, Iowa

---

There is a one story wrap-around porch supported by 14 classical columns complete with balustrade, spindlework along the beadboard ceiling, and an additional balustrade on top of the flat porch roof. The expansive porch wraps from the kitchen on the west side all the way around to the two-story bay window on the east side and includes a rounded section that faces northeast, toward the Mississippi River. There are also two additional porches, both of which face east, that have square columns and no balustrade. These are on the additions. Four of the five exterior doors are transomed and exit onto covered porches. All porch flooring is tongue and groove.

The original foundation is sandstone. The foundation for the additions is limestone. The south and west sides of the house are lined with flower beds using similar sandstone as the original foundation as edging. Additional gardens and trees surround the property.

#### Interior

There is a full basement, part of which still has a dirt floor, under the original section. This is accessed through the laundry/mud room and an outside door on the west side. There is also a five foot deep crawl space under the addition, which is accessible through a trap door in the laundry/mud room floor.

The first floor has twelve foot ceilings, including pressed tin in both the kitchen and dining room. The entry foyer leads to the living room, which has a working fireplace with a simple wooden mantel and brick surround, a bay window, and French doors to the front parlor. The kitchen has a pantry and leads to the dining room. The laundry/mud room is at the rear of the house. A full bath completes the first floor layout.

The second floor has two baths, one with an original claw foot tub and marble sink. The commode for that bath is located across the hall in its own room with a skylight. There are five bedrooms on this floor, one of which is used as an office. The master bedroom has a working fireplace and bay window. It is connected to another bedroom with an interior door. Another bedroom has its own sitting room. The bedroom at the rear of the house was most certainly designated as servant quarters. It is the only room with plain moldings and wide plank floors and is located nearest the back stairs. There is also a cedar lined closet in the back hall.

United States Department of the Interior  
National Park Service

NATIONAL REGISTER OF HISTORIC PLACES  
CONTINUATION SHEET

Section 7 Page 3

Alois and Annie Weber House  
Lee County, Iowa

---

The third floor continues up a curved stairway, using the same continuous banister from the foyer to the third floor, and includes three bedrooms, two of which are connected by a pocket door, and an additional bath, which has been gutted at this point. There are window seats beneath four of the dormers.

The moldings and baseboards throughout the house are wide and decorative. All original interior doorways are transomed.

The additions are both shown on the 1900 Sanborn Fire Insurance Map of Keokuk, as are two additional buildings. One appears to have been a large carriage house and is now a smaller two-car garage, which is listed as a non-contributing structure. The other smaller structure is gone and a garden has taken its place.

#### Integrity

Despite some deterioration of the property due to the elements, the historic integrity remains intact. The neighborhood has maintained its distinguished status and although the house was briefly used as apartments, there is little evidence of it. The first floor bath is the only obvious change to the floor plan. The narrow plank wood floors have been refinished on most of the first and second floors. The marble-topped radiators still provide steam heat. The brick has been painted gray, but the typical Second Empire style has not been compromised.

The major areas which need to be addressed are the roof and porch. Despite maintenance to the nearly flat roof, it has recently leaked and caused damage to the third floor ceilings. Measures have been taken to seal the roof, but it may need additional work. The porch is suffering from age and exposure. The footings were replaced on all porches last summer and steps rebuilt. Stripping of over 100 years worth of paint has begun on the 18 columns and approximately 500 spindles, but it is a slow and arduous task. Some columns and sections of balustrade have been taken down for repair, but none are missing. The chimneys are in need of tuckpointing and all exterior trim needs to be inspected, repaired, scraped, and painted.

United States Department of the Interior  
National Park Service

NATIONAL REGISTER OF HISTORIC PLACES  
CONTINUATION SHEET

Section 8 Page 4

Alois and Annie Weber House  
Lee County, Iowa

---

---

STATEMENT OF SIGNIFICANCE

802 Orleans Avenue, originally the home of Alois and Annie Weber, embodies the distinctive characteristics of the Second Empire style and is locally significant under Criterion C. Its textbook mansard roof, decorative brackets, and pedimented dormer windows make it easy to identify. Inside, the high ceilings, tall, narrow windows, and two-story bay all contribute to the authenticity of the design. The square additions to the rear of the property add to the dominance of the house, but do not detract from the overall design. The unusual Queen Anne wrap-around porch demonstrates the shifting from one design popularity to another. It also visually connects the house to the neighborhood and community.

This structure is significant because it is an excellent representation of architecture from the period of industrial growth in Keokuk, which began in the late 1850's and continued until the turn of the century. During this time, the city matured and acquired many physical assets that still characterize it today. This massive Second Empire example was built circa 1873 and has maintained its period look and feel of power and sophistication.

This structure is one of a number of surviving Second Empire buildings from this period. Few, however, have maintained a high level of integrity. Of those that have, two examples, 220 N. 4<sup>th</sup>, built by Enos H. Harrison in 1857, and 226 Morgan, built by Frank J. Weess in 1880-81, are included in the National Historic Registry. The Alois and Annie Weber House is similar to both of these buildings in size and style and its building date falls between the two. The Weber House, however, is distinctive. The extraordinary porch, with its heavy ornamentation, sets it apart and shows movement in architectural style.

The house is situated on the southwest corner of North Eighth Street and Orleans Avenue and faces north. It is located two blocks from the proposed Park Place/Grand Avenue Historic District, which includes only one Second Empire example. It is also only two blocks from the Mississippi River. The land was originally part of the Louisiana Purchase and, later, the Half-Breed Tract of the Sac and Fox Indians.

This area was, and still is, considered a desirable neighborhood. Orleans Avenue is wide and lined with trees, offering both shade and privacy. The home and separate garage are

United States Department of the Interior  
National Park Service

NATIONAL REGISTER OF HISTORIC PLACES  
CONTINUATION SHEET

Section 8 Page 5

Alois and Annie Weber House  
Lee County, Iowa

---

built on Lot 1, leaving Lot 2 as a lawn and gardens, which provides a buffer from its nearest neighbor.

Alois and Annie Weber contributed to Keokuk's commerce and character by setting examples for others to follow and admire. These two young immigrants, from two different countries, struck out on their own and attained the dream of America in Keokuk, Iowa. The Weber's both demonstrated true pioneer spirit by earning success in the early years of this city's history.

Mr. Weber was "a Keokuk businessman for fifty years, and one of the city's most highly esteemed citizens" according to The Daily Gate City at the time of his death. Alois Weber died in 1917 at his home, 802 Orleans Avenue, where he had lived since having it built in the early 1870's. Alois Weber was considered a "public spirited man who always had the good of the city at heart." He was generous in both industry and charity.

Mr. Weber's life included trials and tribulations, but due to his own diligence, success prevailed. German-born Alois Weber came to America in 1854 at the age of 20. By 1857 Mr. Weber had learned to speak English and made his way to Keokuk "with a twenty franc gold piece in his pocket."

Anna King was born in Ireland in 1835. Her father was a farmer and brought his family to St. Louis in 1847. She came to Keokuk in 1858 and supported herself, as well as her mother and sister, as proprietor of an exclusive millinery shop at 3<sup>rd</sup> and Main. Anna King married Alois Weber in 1866. They lived above her shop until moving to their new home at 8<sup>th</sup> and Orleans with their young son, Frank.

Records show that Annie Weber purchased Lots 1 and 2, Block 131, in the original city of Keokuk at auction in March 1870 for \$1000. The fact that Mrs. Weber purchased the lots indicates that she had means, and a mind, of her own. It is unclear when the house was actually built. While the assessor's sheet lists it at 1880, the 1873 -74 City Directory, and all those forward, lists this location as the Weber address. In addition to purchasing the lots, Mrs. Weber may also have chosen the style of the house, as it was considered very modern and imitated French building fashion.

After working for H. Buel & Co., Mr. Weber opened his own hardware business, A. Weber & Co. in 1868. This enterprise flourished, but after buying out two different

United States Department of the Interior  
National Park Service

NATIONAL REGISTER OF HISTORIC PLACES  
CONTINUATION SHEET

Section 8 Page 6

Alois and Annie Weber House  
Lee County, Iowa

---

partners, James Neill and then C. N. Primean, the financial crisis of 1873 threw Mr. Weber into bankruptcy. He made settlements with his creditors and with the assistance of his wife's finances, continued to do business. Mr. Weber recovered financially and paid all debts which had been cancelled in the court of bankruptcy, much to his former creditors' surprise and appreciation. The following letters were printed in Portrait & Biographical Album of Lee Co., 1887:

St. Louis, April 20, 1885

Alois Weber, Esq., Keokuk, Iowa

Dear Sir: Your esteemed favor of the 16<sup>th</sup> inclosing us a draft for \$ received in settlement of old account. It is indeed refreshing to receive such a letter as yours in this, the nineteenth century, and leads us to believe the world is not quite so bad as some people endeavor to make us believe. To tell you the truth, we have not language at our command to express our opinion in regard to this transaction. We feel like having your letter published in every paper in St. Louis, as most assuredly it goes to show there is one honest man at least in America. If we can serve you in any way, command us. Yours truly, L. M. Rumsey Mfg. Co. Per Rumsey, Sec.

Goshen, N. Y., May 1, 1885

Alois Weber, Esq., Keokuk, Iowa

Dear Sir: Yours of 23d ult. was duly received and draft applied as specified. Localities, of course, differ, and yours may be filled with just such men as you have shown yourself to be in this transaction, but out here you would be decidedly lonesome. Please accept our congratulations on your improved circumstances, which we doubt not, have been largely brought about by the application of the principles you have exhibited in this matter in all your business affairs. Thanking you for the draft, we are, Very truly yours, Rider Engine Co.

A. Weber & Co., located at 6<sup>th</sup> and Main Streets in Keokuk, continued to prosper under Mr. Weber's keen eye. He remained president and treasurer until his death. He also held the position of vice president of Security State Bank and had his hand in many other projects, including the Keokuk Hotel and the Keokuk Savings Bank. Mr. Weber gained success due to his honesty, integrity, and good old-fashioned hard work. His industry was considered "a credit to the city and community," as was his character.

United States Department of the Interior  
National Park Service

NATIONAL REGISTER OF HISTORIC PLACES  
CONTINUATION SHEET

Section 8 Page 7

Alois and Annie Weber House  
Lee County, Iowa

---

Mr. Weber was a man of culture and refinement, but he was not a socialite. He was civic-minded, but did not hold public office. He traveled to every state of the union and several foreign countries. He was one of the few visitors from this country allowed an audience with Pope Leo XIII, when he met his holiness in 1902. While Alois Weber enjoyed travel, his favorite place was his home.

Mr. Weber spent the majority of his productive years in this house. As one of Keokuk's pioneers, he built a prosperous business and contributed to the expansion and betterment of the community. In a rapidly growing area, hardware is essential to building. Export of his company's merchandise via the river and railroad also contributed to the commerce of the city.

Annie Weber also lived in this house until her death in 1898. She maintained her millinery shop from 1856 to 1887 and set quite an example as a self-sufficient woman, a working mother, and wife of a well-known businessman. The fact that her obituary praised her for being a good Christian woman, but omitted her role as an entrepreneur, shows that she was, indeed, a pioneer. The Weber's had one child, Frank, who took over the family business upon his father's death.

This property has maintained its historical integrity and qualifies to be listed on the National Register of Historic Places for its contribution to architecture for its design and construction and as a representation of community history and development.

**Endnotes**

The Webers' descendants have carried on their tradition of community involvement in Keokuk. Their son, Frank, went on to become a very popular and successful member of the business and civic community and lived his whole life in Keokuk. Their grandson, Alois J. (Al) Weber, (son of Frank Weber) was instrumental in founding the Lee County Historical Society and served as its president for many years. He played a vital role in bringing the George M. Verity to Keokuk as a river museum and helped the Miller House Museum become a reality. He also wrote an introduction to the book "Tales of Early Keokuk Homes" by Ray Garrison. This book includes an entry about his grandparents' home, 802 Orleans Avenue.

United States Department of the Interior  
National Park Service

NATIONAL REGISTER OF HISTORIC PLACES  
CONTINUATION SHEET

Section 8 Page 8

Alois and Annie Weber House  
Lee County, Iowa

Floor Plan - First Floor

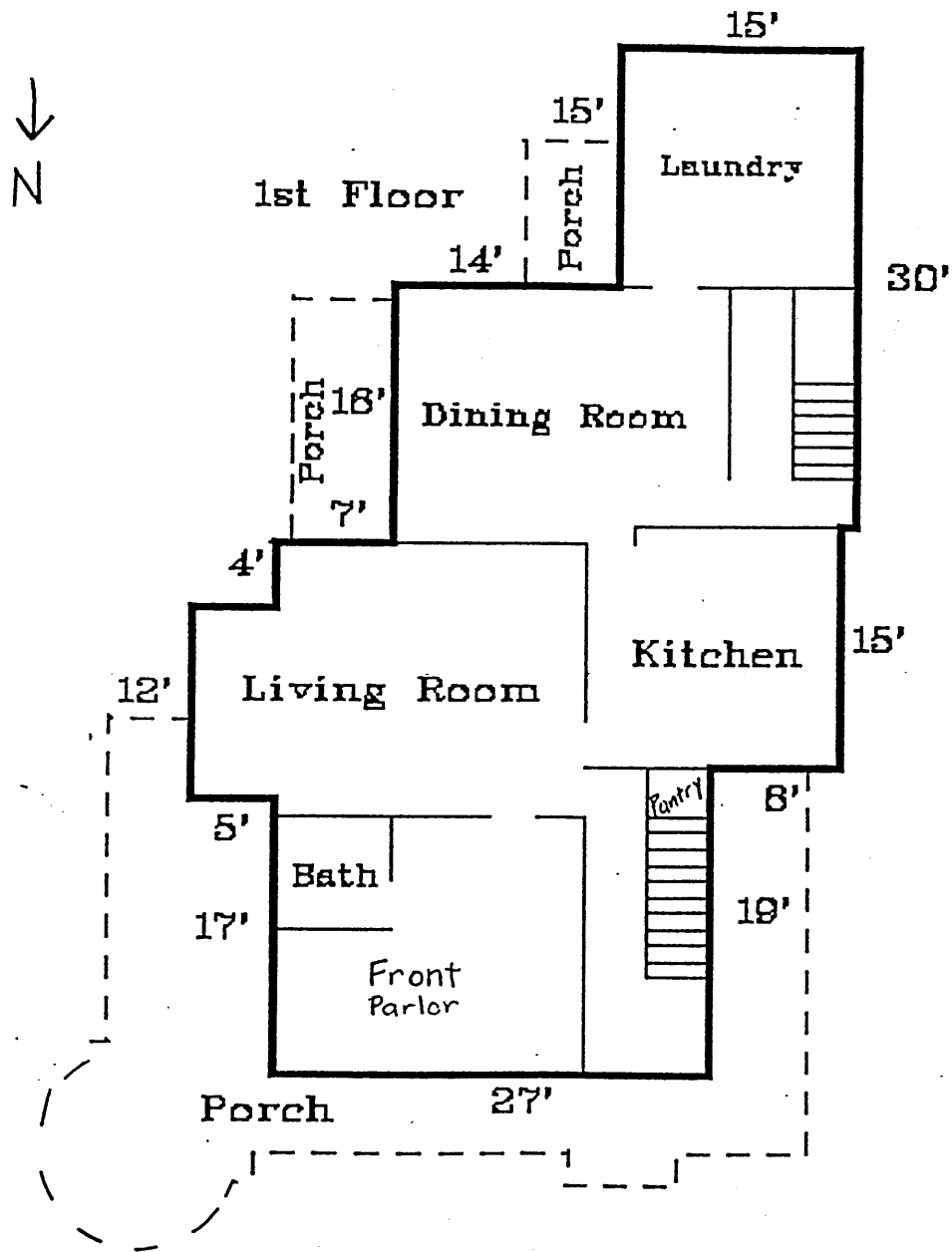

United States Department of the Interior  
National Park Service

NATIONAL REGISTER OF HISTORIC PLACES  
CONTINUATION SHEET

Section 8 Page 9

Alois and Annie Weber House  
Lee County, Iowa

Floor Plan – Second Floor

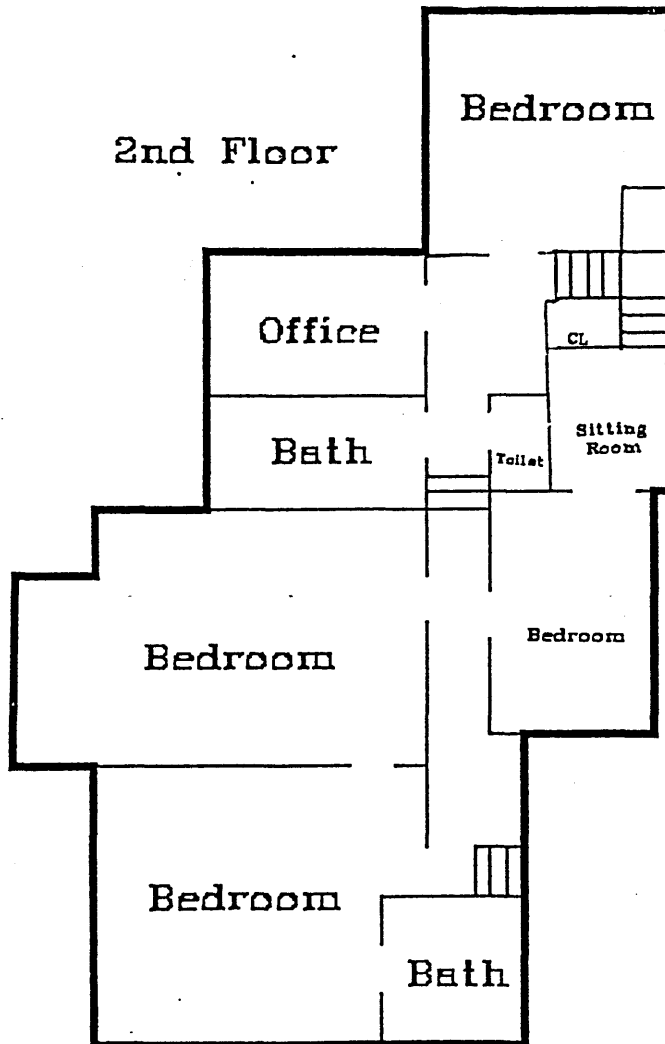



United States Department of the Interior  
National Park Service

NATIONAL REGISTER OF HISTORIC PLACES  
CONTINUATION SHEET

Section 8 Page 10

Alois and Annie Weber House  
Lee County, Iowa

---

Floor Plan – Third Floor

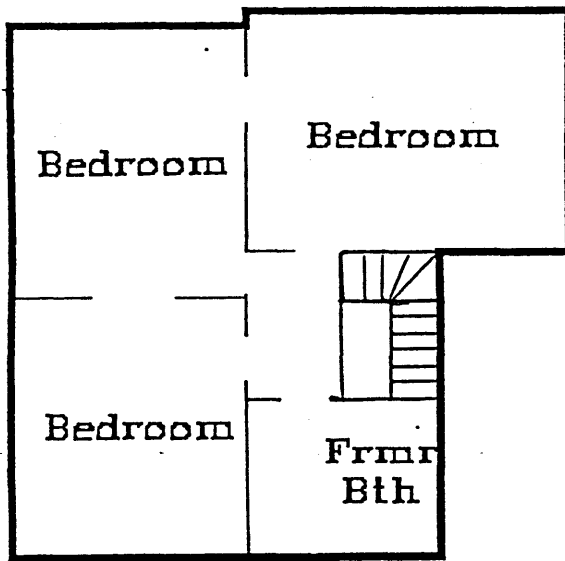

3rd Floor

United States Department of the Interior  
National Park Service

NATIONAL REGISTER OF HISTORIC PLACES  
CONTINUATION SHEET

Section 8 Page 11

Alois and Annie Weber House  
Lee County, Iowa

Insurance Map of Keokuk, Iowa  
Sanborn Map & Publishing Co., 117 Broadway, New York, September, 1900.

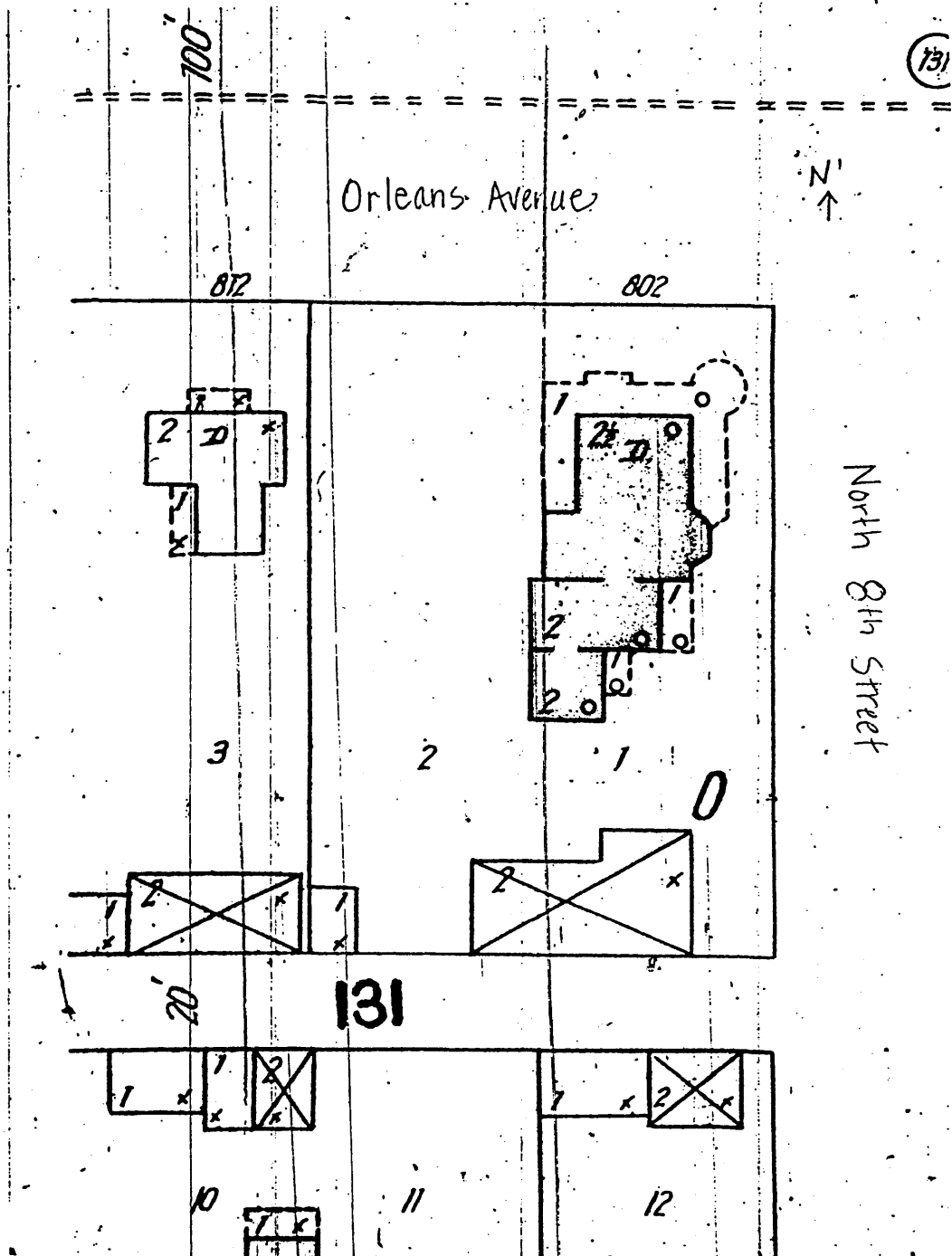

United States Department of the Interior  
National Park Service

NATIONAL REGISTER OF HISTORIC PLACES  
CONTINUATION SHEET

Section 8 Page 12

Alois and Annie Weber House  
Lee County, Iowa

Map of Keokuk, Iowa  
Media Ventures, Inc., 1993.

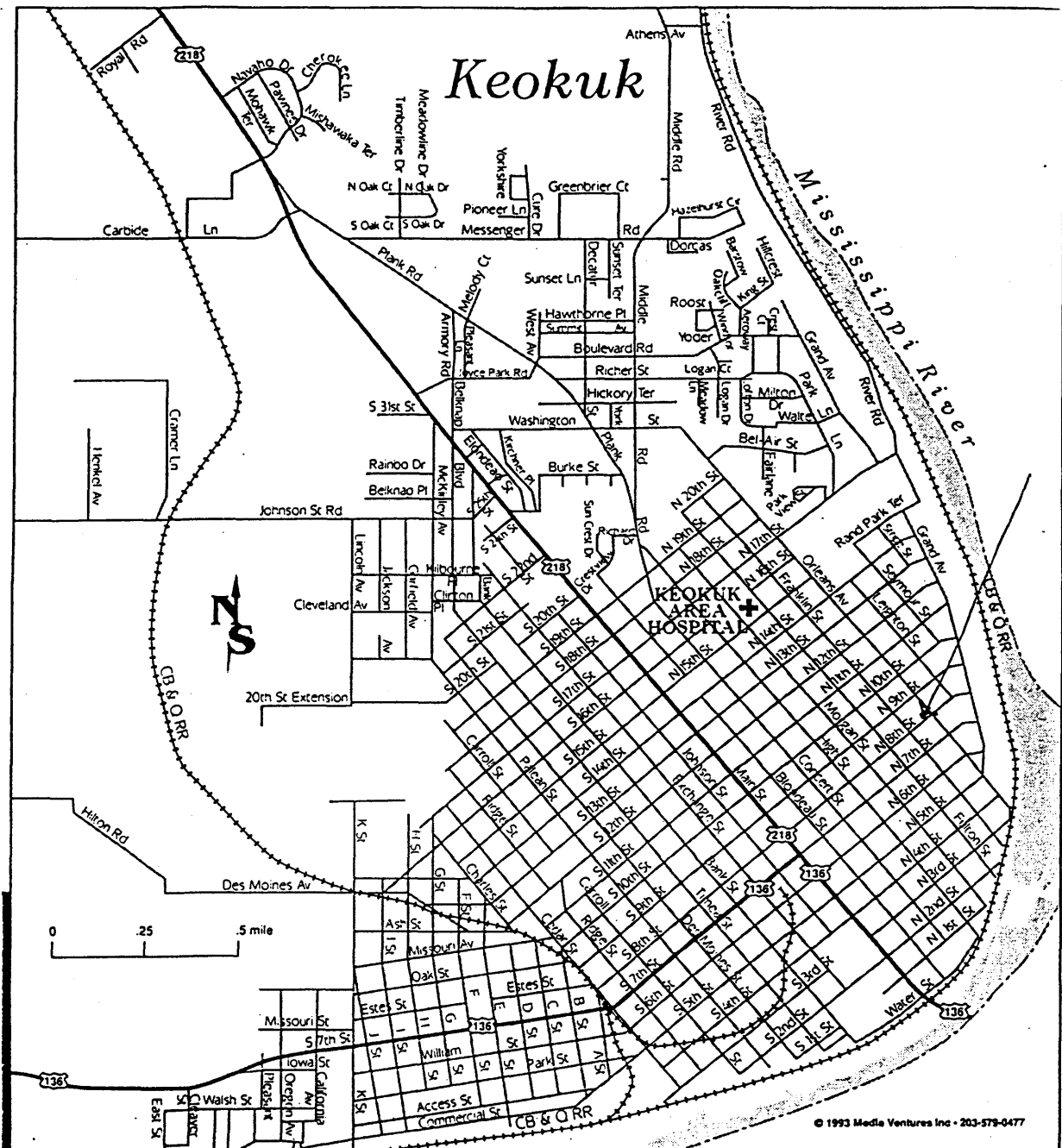

United States Department of the Interior  
National Park Service

NATIONAL REGISTER OF HISTORIC PLACES  
CONTINUATION SHEET

Section 8 Page 13

Alois and Annie Weber House  
Lee County, Iowa

Advertisement for A. Weber & Co.

Daily Democrat, August 1, 1887.

✦A. ✦WEBER ✦& ✦CO. ✦

# WHOLESALE HARDWARE

Cutlery, Agricultural Implements, Mechanic's Tools,

BUILDERS' -- SUPPLIES, -- ETC.

528 Main Street, cor. Sixth,

KEOKUK, --- --- --- IOWA.

Agents for HOWE'S SCALES and "Glidden" BARB WIRE.

United States Department of the Interior  
National Park Service

NATIONAL REGISTER OF HISTORIC PLACES  
CONTINUATION SHEET

Section 8 Page 14

Alois and Annie Weber House  
Lee County, Iowa

Advertisement for A. Weber Co.  
McCoy's Keokuk City Directory, 1896 - 97.

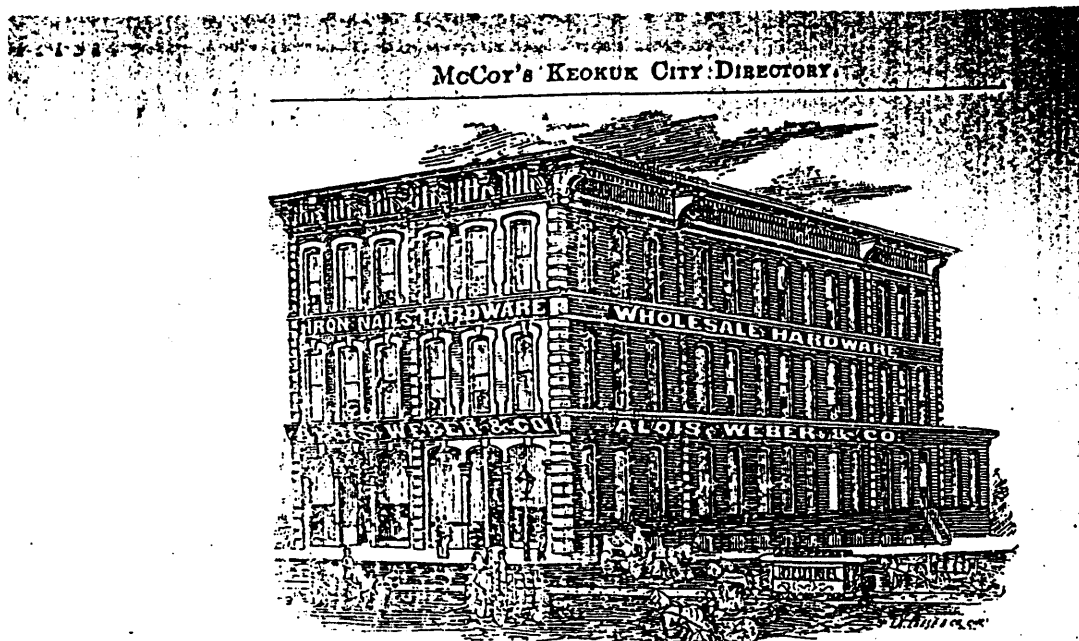

**A. WEBER CO.**  
**Wholesale Hardware, Iron,**

**Cutlery, Nails, Wire,**

**TINWARE, ETC.**

**526 and 528 Main St., Cor. 6th.**

**TELEPHONE 73.**

**KEOKUK, IOWA.**

United States Department of the Interior  
National Park Service

NATIONAL REGISTER OF HISTORIC PLACES  
CONTINUATION SHEET

Section 8 Page 15

Alois and Annie Weber House  
Lee County, Iowa

Advertisements for Annie (King) Weber's millinery shop taken from *The Daily Gate City* newspaper.

Jan. 27, 1863

July 1, 1866

**MRS. A. KING**

IN THE CITY OF GATE CITY, IOWA, I HAVE OPENED A MILLINERY SHOP, AND AM PREPARED TO RECEIVE THE PATRONAGE OF THE LADIES OF THIS CITY AND THE SURROUNDING COUNTRY. I HAVE ON HAND A LARGE STOCK OF THE LATEST FASHIONS IN MILLINERY, AND AM PREPARED TO MAKE UP TO ORDER. I ALSO HAVE ON HAND A LARGE STOCK OF FINE FABRICS, AND AM PREPARED TO MAKE UP TO ORDER. I AM ALSO PREPARED TO MAKE UP TO ORDER. I AM ALSO PREPARED TO MAKE UP TO ORDER.

**NO. 12, MAIN STREET, GATE CITY, IOWA.**

**MRS. A. KING**

IN THE CITY OF GATE CITY, IOWA, I HAVE OPENED A MILLINERY SHOP, AND AM PREPARED TO RECEIVE THE PATRONAGE OF THE LADIES OF THIS CITY AND THE SURROUNDING COUNTRY. I HAVE ON HAND A LARGE STOCK OF THE LATEST FASHIONS IN MILLINERY, AND AM PREPARED TO MAKE UP TO ORDER. I ALSO HAVE ON HAND A LARGE STOCK OF FINE FABRICS, AND AM PREPARED TO MAKE UP TO ORDER. I AM ALSO PREPARED TO MAKE UP TO ORDER. I AM ALSO PREPARED TO MAKE UP TO ORDER.

May 1873

**MILLINERY**

Dry Goods, Notions, &c.,

—AT—

**Mrs. Weber's**

**LADIES' BAZAR**

Jan. 20, 1867

**MRS. WEBER.**

**LADIES' BAZAR,**

Corner 3d and Main Streets.

Millinery and Fancy Dry Goods,

CLOAKS, SHAWLS, CLOTHES, LACE, FLOWERS,

RIBBONS, HOSIERY, HOOP SKIRTS,

CORSETS, &c.

An examination of my stock is respectfully solicited.

Oct 20.

1875

**Millinery, Dry Goods**

**NOTIONS, &c.,**

—AT—

**Mrs. Weber's Ladies' Bazar.**

C. r. Main & 3d Sts.

**AUSTIN BLAND,**

**BILL POSTER AND CITY PORTER**

United States Department of the Interior  
National Park Service

NATIONAL REGISTER OF HISTORIC PLACES  
CONTINUATION SHEET

Section 9 Page 16

Alois and Annie Weber House  
Lee County, Iowa

---

**Bibliography**

"A Peaceful End." The Gate City, Keokuk, Iowa. February, 1, 1898.

Abstract of Title. Lots 1 and 2 in Block 131, Keokuk, Lee County, Iowa.

"Al Weber, Member of Pioneer Keokuk Family Dies Monday." The Daily Gate City, Keokuk, Iowa. January 11, 1972.

"Alois Weber is Called by Death." The Daily Gate City, Keokuk, Iowa. September 12, 1917.

Census. Lee County, 2<sup>nd</sup> Ward. 1870, p. 221.

Garrison, Raymond. Tales of Early Keokuk Homes. Hamilton, IL: The Hamilton Press, 1959.

Gebhard, David, and Gerald Mansheim. Buildings of Iowa. New York: Oxford University Press, 1993.

"Insurance Map of Keokuk, Iowa, 1900." New York: Sanborn Map & Publishing Co., 1900.

Keokuk City Directories, 1856 – 1917.

Keokuk City Directory, 1873 – 74.

Lee County Assessor's Office. Assessment sheet for 802 Orleans Avenue, Keokuk, IA.

McAlester, Virginia, and Lee McAlester. A Field Guide to American Houses. New York: Alfred A. Knopf, 1984.

Noe, Rita. Stroll Historic Keokuk. Keokuk, Iowa: Shagbark Studio, 1988.

United States Department of the Interior  
National Park Service

NATIONAL REGISTER OF HISTORIC PLACES  
CONTINUATION SHEET

Section 9 & 10 Page 17

Alois and Annie Weber House  
Lee County, Iowa

---

Plymat, William, Jr. *Victorian Architecture of Iowa*. Des Moines, Iowa: Palladian Publishing Co., 1997.

*Portrait & Biographical Album of Lee County (Iowa)*, 1887, pp. 479 –481.

**Verbal Boundary Description**

Lots 1 and 2, Block 131, City of Keokuk, Lee County, Iowa.

**Boundary Justification**

These are the historic boundaries of the property which still retains its integrity as a distinct residential property.



United States Department of the Interior  
National Park Service

NATIONAL REGISTER OF HISTORIC PLACES  
CONTINUATION SHEET

Section Photos Page 18

Alois and Annie Weber House  
Lee County, Iowa

---

**Photographs**

All photographs were taken by Diane Berner. She retains all negatives. The first ten were taken in June 2001. Photos 11 – 15 were taken in October 2001.

1. North façade – looking south
2. West façade – looking northeast
3. North façade – looking southeast
4. East façade – looking northwest
5. Front door – looking south
6. One of two south dormers – looking northeast
7. Detail of brackets – looking southwest
8. Detail of spindlework – facing northeast
9. Interior bay in master bedroom – looking east
10. Interior second floor bath – looking northeast
11. Non-contributing structure – looking northwest
12. East façade – looking west
13. South façade – looking north
14. Dining room tin ceiling
15. Living room mantel