

584

# National Register of Historic Places Registration Form

This form is for use in nominating or requesting determinations for individual properties and districts. See instructions in National Register Bulletin, *How to Complete the National Register of Historic Places Registration Form*. If any item does not apply to the property being documented, enter "N/A" for "not applicable." For functions, architectural classification, materials, and areas of significance, enter only categories and subcategories from the instructions. Place additional certification comments, entries, and narrative items on continuation sheets if needed (NPS Form 10-900a).

## 1. Name of Property

Historic name Link, Oliver L. and Catherine, House

Other names/site number N/A

Name of related Multiple Property Listing N/A

## 2. Location

Street & number 1005 Jefferson

N/A

not for publication

City or town St. Charles

N/A

vicinity

State Missouri Code MO County St. Charles

Code 183

Zip code 63301

## 3. State/Federal Agency Certification

As the designated authority under the National Historic Preservation Act, as amended,

I hereby certify that this X nomination     request for determination of eligibility meets the documentation standards for registering properties in the National Register of Historic Places and meets the procedural and professional requirements set forth in 36 CFR Part 60.

In my opinion, the property X meets     does not meet the National Register Criteria. I recommend that this property be considered significant at the following level(s) of significance:

    national     statewide   X   local

Applicable National Register Criteria:     A   X   B   X   C     D

*Mark A. Miles*

*June 13, 2013*

Signature of certifying official/Title Mark A. Miles, Deputy SHPO

Date

Missouri Department of Natural Resources

State or Federal agency/bureau or Tribal Government

In my opinion, the property     meets     does not meet the National Register criteria.

Signature of commenting official

Date

Title

State or Federal agency/bureau or Tribal Government

## 4. National Park Service Certification

I hereby certify that this property is:

entered in the National Register

    determined eligible for the National Register

    determined not eligible for the National Register

    removed from the National Register

    other (explain:)

*Joe Edson H. Beall*

*8.6.13*

Signature of the Keeper

Date of Action

Link, Oliver L. and Catherine, House  
Name of Property

St. Charles, MO  
County and State

**5. Classification**

**Ownership of Property**  
(Check as many boxes as apply.)

<input checked="" type="checkbox"/>	private
<input type="checkbox"/>	public - Local
<input type="checkbox"/>	public - State
<input type="checkbox"/>	public - Federal

**Category of Property**  
(Check only one box.)

<input checked="" type="checkbox"/>	building(s)
<input type="checkbox"/>	district
<input type="checkbox"/>	site
<input type="checkbox"/>	structure
<input type="checkbox"/>	object

**Number of Resources within Property**  
(Do not include previously listed resources in the count.)

Contributing	Noncontributing	
1	1	buildings
		sites
	1	structures
		objects
1	2	<b>Total</b>

**Number of contributing resources previously listed in the National Register**

0

**6. Function or Use**

**Historic Functions**

(Enter categories from instructions.)

DOMESTIC/single dwelling

DOMESTIC/secondary structure

**Current Functions**

(Enter categories from instructions.)

DOMESTIC/single dwelling

DOMESTIC/secondary structure

**7. Description**

**Architectural Classification**

(Enter categories from instructions.)

LATE VICTORIAN/Richardsonian Romanesque

**Materials**

(Enter categories from instructions.)

foundation: STONE/Limestone

walls: BRICK

roof: STONE/Slate

other: WOOD/Weatherboard

NARRATIVE DESCRIPTION ON CONTINUATION PAGES

Link, Oliver L. and Catherine, House  
Name of Property

St. Charles, MO  
County and State

**8. Statement of Significance**

**Applicable National Register Criteria**

(Mark "x" in one or more boxes for the criteria qualifying the property for National Register listing.)

- A Property is associated with events that have made a significant contribution to the broad patterns of our history.
- B Property is associated with the lives of persons significant in our past.
- C Property embodies the distinctive characteristics of a type, period, or method of construction or represents the work of a master, or possesses high artistic values, or represents a significant and distinguishable entity whose components lack individual distinction.
- D Property has yielded, or is likely to yield, information important in prehistory or history.

**Criteria Considerations**

(Mark "x" in all the boxes that apply.)

Property is:

- A Owned by a religious institution or used for religious purposes.
- B removed from its original location.
- C a birthplace or grave.
- D a cemetery.
- E a reconstructed building, object, or structure.
- F a commemorative property.
- G less than 50 years old or achieving significance within the past 50 years.

STATEMENT OF SIGNIFICANCE ON CONTINUATION PAGES

**9. Major Bibliographical References**

**Bibliography** (Cite the books, articles, and other sources used in preparing this form.)

**Previous documentation on file (NPS):**

- preliminary determination of individual listing (36 CFR 67 has been requested)
- previously listed in the National Register
- previously determined eligible by the National Register
- designated a National Historic Landmark
- recorded by Historic American Buildings Survey # \_\_\_\_\_
- recorded by Historic American Engineering Record # \_\_\_\_\_
- recorded by Historic American Landscape Survey # \_\_\_\_\_

**Primary location of additional data:**

- State Historic Preservation Office
- Other State agency
- Federal agency
- Local government
- University
- Other

Name of repository: \_\_\_\_\_

Historic Resources Survey Number (if assigned): SC-AS-008-128

**Areas of Significance**

ARCHITECTURE

INVENTION

**Period of Significance**

1895-1942

**Significant Dates**

1895

**Significant Person**

(Complete only if Criterion B is marked above.)

Link, Oliver L.

**Cultural Affiliation**

N/A

**Architect/Builder**

Link, Oliver L.

**10. Geographical Data**

Link, Oliver L. and Catherine, House  
Name of Property

St. Charles, MO  
County and State

**Acreege of Property** Less than 1 acre

**Latitude/Longitude Coordinates**

Datum if other than WGS84: N/A  
(enter coordinates to 6 decimal places)

1                                            
Latitude: Longitude:

3                                            
Latitude: Longitude:

2                                            
Latitude: Longitude:

4                                            
Latitude: Longitude:

**UTM References**

(Place additional UTM references on a continuation sheet.)

       NAD 1927 or   x   NAD 1983

1   15     717775     4295660    
Zone Easting Northing

3                                                                 
Zone Easting Northing

2                                                                 
Zone Easting Northing

4                                                                 
Zone Easting Northing

**Verbal Boundary Description** (On continuation sheet)

**Boundary Justification** (On continuation sheet)

**11. Form Prepared By**

name/title Timothy P. Maloney and Karen Bode Baxter

organization Karen Bode Baxter, Preservation Specialist date June 11, 2013

street & number 5811 Delor telephone (314) 353-0593

city or town St. Louis State MO zip code 63109

e-mail Karen@bodebaxter.com

**Additional Documentation**

Submit the following items with the completed form:

- **Maps:**
  - A **USGS map** (7.5 or 15 minute series) indicating the property's location.
  - A **Sketch map** for historic districts and properties having large acreage or numerous resources. Key all photographs to this map.
- **Continuation Sheets**
- **Photographs**
- **Owner Name and Contact Information**
- **Additional items:** (Check with the SHPO or FPO for any additional items.)

**Paperwork Reduction Act Statement:** This information is being collected for applications to the National Register of Historic Places to nominate properties for listing or determine eligibility for listing, to list properties, and to amend existing listings. Response to this request is required to obtain a benefit in accordance with the National Historic Preservation Act, as amended (16 U.S.C.460 et seq.).

**Estimated Burden Statement:** Public reporting burden for this form is estimated to average 18 hours per response including time for reviewing instructions, gathering and maintaining data, and completing and reviewing the form. Direct comments regarding this burden estimate or any aspect of this form to the Office of Planning and Performance Management, U.S. Dept. of the Interior, 1849 C. Street, NW, Washington, DC.

Link, Oliver L. and Catherine, House  
Name of Property

St. Charles, MO  
County and State

## Photographs

Submit clear and descriptive photographs. The size of each image must be 1600x1200 pixels (minimum), 3000x2000 preferred, at 300 ppi (pixels per inch) or larger. Key all photographs to the sketch map. Each photograph must be numbered and that number must correspond to the photograph number on the photo log. For simplicity, the name of the photographer, photo date, etc. may be listed once on the photograph log and doesn't need to be labeled on every photograph.

## Photo Log:

Name of Property: Link, Oliver L. and Catherine, House

City or Vicinity: St. Charles

County: St. Charles State: MO

Photographer: Sheila Findall

Date  
Photographed: December 2012

Description of Photograph(s) and number, include description of view indicating direction of camera:

Photographer: Sheila Findall

December 2012

Negatives with Karen Bode Baxter, 5811 Delor Street, St. Louis, MO 63109

Photo #1: Exterior, looking southeast at north façade and west elevation

Photo #2: Exterior, looking southwest at north façade and east elevation

Photo #3: Exterior, looking southeast at weather vein on the northeast corner

Photo #4: Exterior, looking south at north façade entry

Photo #5: Exterior, looking northwest at south and east elevations

Photo #6: Exterior, looking northeast at south and west elevations

Photo #7: Exterior, looking south at garage north elevation

Photo #8: Interior, first floor, foyer, looking northwest from the southeast corner

Photo #9: Interior, first floor, living room, looking northeast from the southwest corner

Photo #10: Interior, first floor, dining room, looking northwest from the southeast corner

Photo #11: Interior, first floor, butler's pantry, looking east from the west end

Photo #12: Interior, second floor, north stairs, from the east looking west down

Photo #13: Interior, second floor, hall, from the north end looking southwest

Link, Oliver L. and Catherine, House  
Name of Property

St. Charles, MO  
County and State

**Figure Log:**

Include figures on continuation pages at the end of the nomination.

Figure 1: Map Locating Property

Figure 2: 1905 Plat Map

Figure 3: 1909 Sanborn Map

Figure 4: 1917 Sanborn Map

Figure 5: 1929 Sanborn Map

Figure 6: Basement Floor Plan

Figure 7: First Floor Plan

Figure 8: Second Floor Plan

Figure 9: Attic Floor Plan

Figure 10: Photo of St. Charles City Officials ca. 1899-1904

Figure 11: Photo of Oliver Link's Family ca. 1917

Figure 12: Photo of the American Car and Foundry Company

Figure 13: Illustration of Oliver Link's Patent of the Ash Pan

Figure 14: Illustration of Oliver Link's Patent of the Water Cooler

Figure 15: Illustration of Oliver Link's Patent of the Cooler

Figure 16: Illustration of Oliver Link's Patent of the Upper Buffering Mechanism

Figure 17: Illustration of Oliver Link's Patent of the Trap Door

Figure 18: Illustration of Oliver Link's Patent of the Trap Door

National Register of Historic Places  
Continuation Sheet

Section number 7 Page 1

Link, Oliver L. and Catherine, House
Name of Property
St. Charles, MO
County and State
N/A
Name of multiple listing (if applicable)

**SUMMARY**

The Oliver L. and Catherine Link House at 1005 Jefferson, St. Charles (St. Charles County), Missouri was constructed in 1895 based upon designs of the owner. It is a two and one-half story, yellow brick single family house with a raised basement. It is located on a large lot on the south side of Jefferson between Ninth Street and Kings Highway, in a late nineteenth and early twentieth century neighborhood seven blocks from the St. Charles County Courthouse and less than ten blocks from the historic central business district that parallels the Missouri River. This Richardsonian Romanesque design has the characteristic hipped roof with cross gables, round tower with a conical roof, uniform masonry finish highlighted by occasional limestone belt courses, large round arched opening over the entryway, and one-over-one sashed windows that distinguish this style.

**EXTERIOR FEATURES**

The complex roofline of this two and one-half story house is tied together by the monochromatic gray slate and its wide enclosed eaves. Both the main hipped roof and the conical roof on the two and one-half story round tower flare out over the eaves to visually frame the roof elements separate from the masonry walls and embellishments below. There are pedimented cross gables facing both the east and west elevations and a hipped roof extension on the rear of the house. Facing west behind the pedimented gable is a hipped roof, single sashed window dormer above a two story rear sleeping porch. The tower is at the northeast corner of the house and is capped with a uniquely designed copper weathervane featuring what appear to be sunflowers. To the west of the tower there is a hipped roof dormer with paired sashed windows. Three, very tall, slender brick chimneys with simple corbelled caps extend up from each secondary elevation.

All elevations of the yellow brick house share the same basic design elements. Windows are generally rectangular, one-over-one sashed windows within shallow, segmental arched openings that have brick lintels and limestone sills (rusticated on secondary elevations but smooth on the tower and façade). A smooth stone course separates the coursed, rusticated limestone foundation from the yellow brick walls.

The façade of the building is divided into three vertical bays, including the round tower on the east corner. The two other bays have a hipped roof dormer centered above them. The two and one-half story tower is divided into five sections, separated by the continuous limestone sills that wrap the tower at each level and the eaves of the conical roof. The tower is wrapped by three bays of single window openings, sashed on the first and second floor and shallow awning windows on the third floor. The westernmost bay incorporates the large round arched entryway with its brick arch surround. Above the entry is a wide window opening that has a pilaster strip mullion between the paired sashes. The middle bay features the only round arched top sashed window with its brick arch surround that matches the one on the entryway and above this is a single sashed window.

National Register of Historic Places  
Continuation Sheet

Section number 7 Page 2

Link, Oliver L. and Catherine, House
Name of Property
St. Charles, MO
County and State
N/A
Name of multiple listing (if applicable)

The wood paneled recessed entry has a distinctive, transomed, carved wood entry door, which is flanked by paneled pilasters and transomed, fixed, single light windows, all of which feature beveled glass. The door has a single, nearly square, beveled glass light with a molded shelf at the base. Framing the top of this light is an embossed swag and below is the original doorbell mechanism and a smaller recessed panel with an embossed shield motif that features the overlapping O and L emblem (for Oliver Link) and flanking this panel are two embossed vases with bouquets of cattails (a motif carried into the interior as well and apparently linked with the "cat" in Catherine's name. Above the door is a glass globe porch pendant light. The front entry stoop blends into the house with matching foundation stones and brick railings capped with limestone nearly matching the height of the continuous sill for the adjacent first floor window in the center bay and on the tower. Broad limestone steps lead up to the concrete floor stoop which spans from the west corner of the house to the window opening in the center bay.

The roof literally rounds the corner behind the tower with the rounded corner, two-story open spooning porch. On each level there are simple Doric style, tapered porch columns that rest on squared bases to which are anchored the simple wood railings of the porch. Angled on the south end of this porch is a simple set of steps to the side yard. Since one of the chimneys (and its interior fireplaces) is positioned along this section of the east elevation, the only windows opening into the porch are the one bay of the corner tower windows and the Jefferson windows at the opposite end that form the north facet of the canted two-story bay below the pedimented gable. Within the pedimented gable is a single, sashed window surrounded by diamond and rectangular shaped slate tile walls. The other two facets of the canted bay has single sashed windows with a basement level, single light awning window facing east. Adjacent to the canted bay is a single vertical row of narrow sashed windows (both stained glass) and at the very rear of the east elevation is a two-over-two sashed window on the first floor with another basement level awning window below.

Another chimney is centered in the hipped roof extension on the narrow south elevation. This elevation is basically unadorned except for the vertical bay of sashed windows near the west end.

The west elevation of the house is divided into three components. The two-story, shallow pitched roof, corner sleeping porch is enclosed on the second floor above the open first floor porch with its simple squared posts, wood railings and wooden porch floor. Below this porch is latticework and the wooden steps and railings enter the porch from the west. The sleeping porch has two window openings facing west and one facing south, each with shallow arched, transomed openings that have three (newer) six-light casement windows within each opening. The middle section of this elevation is another canted bay with a pedimented gable end faced with decorative slate shingles. This pediment does not have a window, nor does the west face of the bay below, since the chimney pierces through the ridge of this pedimented bay. The two angled sides of the canted bay have sashed windows on both the first and second floor with basement level, single light, awning windows below. The front section of this elevation is unadorned except for the large, sashed, stained glass window at the stair landing.



National Register of Historic Places  
Continuation Sheet

Section number 7 Page 3

Link, Oliver L. and Catherine, House
Name of Property
St. Charles, MO
County and State
N/A
Name of multiple listing (if applicable)

**INTERIOR FEATURES**

The interior of the house has seven rooms on the first floor. The reception hall (foyer) and the front parlor span across the front of the house. The reception hall incorporates the elaborate, open, dog-leg stairs with the dining room positioned behind the reception hall. Behind the front parlor is another parlor, known as the drawing room. Behind the drawing room is a narrow butler's pantry that serves as a back hallway from the dining room to the half bathroom at the east end as well as to the kitchen to the south. On the second floor, there were originally five bedrooms, but one has since been turned into a master bath/laundry room. The laundry room is positioned above the reception hall and the bedrooms open into the linear hallway that runs north to south. The third floor was originally an attic but was converted into a ballroom complete with a wet bar in the tower, but it currently is serving as the dorm-like apartment for the Kuypers' daughter. It also has a full bathroom that incorporated the Link's original claw foot bathtub salvaged from the second floor bathroom.

The interior finishes vary slightly depending on the prominence of the rooms, but they share the common elements of tall ceilings, original plaster finishes on the walls and ceilings, stained, wood, five paneled doors, and wood stained trim around windows, doors and baseboards. Most of the house even retains the radiator heat, electric push button switch plates and several rooms have the original fire alarms mounted high on the wall. The three member baseboards and the door and window trim profile is the same throughout the house; the trim is a very unusual beaded trim with mitered corners that from a distance appears to be a back band trim. The most elaborate finishes are reserved from the front reception hall and the front parlor, including the use of white oak in the reception hall and parlor, with hickory featured in the drawing room. Elsewhere the wood trim seems to be pine and the floors outside these principal rooms also appears to have originally been pine as well, although the dining room and second floor hallway have been overlaid with oak floors in recent years.

The most elaborate decorative details are within the reception hall. The interior side of the entry door and windows forms its north wall, all stained wood. The wide doorway to the parlor is spanned by spooled fretwork with cattails carved into its end panels. Opposite is one of the historic gas fired, wood fire place mantels that retains its original cast iron hearth and marbled brown tile surround and hearth floor. On the south side of the reception hall is the doorway to the dining room next to a door to a small closet under the stairs but most of the south wall is actually the wood paneled wall of the staircase. Each panel is framed with egg and dart molding, as are the panels in the newel post, which has a foliated capital-like cap which features the original gas and electric light fixture (but the original red glass was destroyed by Link's own golf swing, so its glass was replaced). Along the front of the staircase, next to the fireplace is a wood paneled warming bench. The balusters on the staircase are squared, but they are bowed in profile with three long grooves on each facet. At the landing is a stained glass, wood sashed window.

The other principal rooms on the first floor also have some distinctive elements. Both the front parlor and the dining room retain their original wood stained fireplace mantels and while the tile surround the hearth has been replaced with glazed brick in the dining room, the parlor retains its

National Register of Historic Places  
Continuation Sheet

Section number 7 Page 4

Link, Oliver L. and Catherine, House
Name of Property
St. Charles, MO
County and State
N/A
Name of multiple listing (if applicable)

original white/green/brown marbled tile as well as the original cast iron insert for the historic gas fired fireplace. The front parlor's most distinctive feature, besides the fretwork opening to the reception hall, is the rounded corner of the tower with its three windows. It connects through a pocket door to the drawing room which incorporates the Jefferson window into the spooning porch. The dining room still retains one of the fire alarms as well as the built-in china cabinet (next to the door to the butler's pantry) which originally had a pass-through drawer into the kitchen. The butler's pantry's north wall is lined with simple stained cabinets, one of which is a lead lined ice box. When water was run into the house in 1902-1903 (one of the early homes to do so given the fact that Oliver Link worked with the city on their new water system), the east end of the butler's pantry was enclosed as a small half-bath with a tiny, porcelain corner sink and a chain pull style toilet, both still in use today. The kitchen has been remodeled over the years but it does retain the original fireplace mantel even though the hearth has been covered with glass fire screen.

The doorway and stairs to the basement open into the kitchen. The basement has a poured concrete floor that was added in 1950 and the room below the first floor kitchen originally served as the summer kitchen. It is separated by a wall with a four paneled door from the rest of the basement. The cistern is still plumbed into the basement limestone walls. The northeast corner of the basement retains the original shelving and paneled bi-fold doors of what was a root cellar.

On the second floor, the southeast room incorporates the rounded corner of the tower and was originally Catherine Link's upstairs sewing parlor. The room over the reception hall was originally the son's (Warren "Bud" Link's) bedroom, but it has been converted into a master bath/laundry. The doorways into the hall are transomed with the one over the drawing room (which was the Link girls' room) has a stained glass transom and that room also has another Jefferson window opening into the upper level of the spooning porch. It has two panels at the base while its other windows have three panels. The southeast corner bedroom originally served as the maid's room and there is a back staircase that has been blocked off that is accessed from within this bedroom. An enclosed straight flight staircase (open on the third floor) has been added, along the west side of the second floor hallway, utilizing a portion of the original master bedroom located over the dining room. This bedroom has a bay and a Jefferson window leading out to a sleeping porch that is now enclosed and currently used as a study.

### ALTERATIONS AND INTEGRITY ISSUES

Very little has changed on this house since the Links lived there, except for work to maintain and restore the original elements of the house. The slate roof on the conical tower was replaced with matching tile this year, along with an exact replica of the original copper weathervane. The front porch steps now have wood railings. The dining room and second floor hallway floors have been overlaid with oak and as mentioned above an additional staircase has been enclosed to the third floor from the second floor hallway, but it retained the original hallway wall. The house has also been retrofitted for central air conditioning and some of the bedrooms have been carpeted.

National Register of Historic Places  
Continuation Sheet

Section number 7 Page 5

Link, Oliver L. and Catherine, House
Name of Property
St. Charles, MO
County and State
N/A
Name of multiple listing (if applicable)

Besides some upgrades in the bathrooms and the kitchen, little else has been changed on the interior. On the rear porch, the second floor sleeping porch has replacement Pella windows.

The major alteration to the property has been the replacement of the original outbuildings with a new gabled roof, frame garage that has wood siding and round arched, multipaned windows facing the house as well as a simple portico side entry. The other recent addition to the property is a small lattice sided, covered gazebo.

National Register of Historic Places  
Continuation Sheet

Section number 8 Page 6

Link, Oliver L. and Catherine, House
Name of Property
St. Charles, MO
County and State
N/A
Name of multiple listing (if applicable)

## SUMMARY

The Oliver L. and Catherine Link House, located at 1005 Jefferson, St. Charles (St. Charles County) is eligible for the National Register of Historic Places under Criterion C: Architecture for its distinctive Richardsonian Romanesque design. The two and a half story house has a large round tower on one corner and heavy arches above the entry and front façade first floor window as well as a cross-gabled roof with a slight flair at the eaves and heavy dormers. It also has a monochromatic appearance with its limestone and yellow brick, all typical of Richardsonian Romanesque design and it is one of only three Richardsonian Romanesque designs in the large Midtown St. Charles neighborhood (which has more than 500 residences).<sup>1</sup> The Oliver L. and Catherine Link House was designed by its owner, Oliver Link, who was an executive for the American Car and Foundry Company who also designed multiple inventions for the company.<sup>2</sup> Link was also an important member of the St. Charles community and was elected as a member of the city council numerous times serving a total of nineteen years (non-consecutively) on the council as well as spending time working for the water department. Because of Oliver Link's prominence in the community both as an inventor and executive for the town's major industry, and because this house is the most closely associated building with Oliver Link, it is also eligible under Criterion B: Invention for its association with Oliver Link. The Oliver L. and Catherine Link House is locally significant and the period of significance is 1895 through 1942, which spans the time from the completion of the house to Oliver Link's death.

## BUILDING HISTORY

Oliver L. and Catherine Link purchased the land where the Oliver L. and Catherine Link House stands on in 1894. Link had designed the house himself in 1892, even before he and his wife had purchased the land, and according to tax records the house was completed in 1895.<sup>3</sup> Link designed the house with cost savings in mind, not just in the construction but also in the maintenance and services for the house after the Link family moved in. Link limited the use of windows and of more expensive woods. He only used white oak for the front parlor reception hall and the elaborate staircase and restricted use of hickory for the drawing room/rear parlor

<sup>1</sup> Rubach, Brenda S., *Phase 2 Architectural/Historical Survey of the Mid-Town and Commons Neighborhoods, St. Charles, MO* (St. Charles, MO: City of St. Charles, 2012), 38.

<sup>2</sup> St. Charles, Missouri, St. Charles County Historical Society Archives, Street Address Files, "Their Dream House."

<sup>3</sup> St. Charles, MO, St. Charles County Historical Society Archives, County Courthouse Files, "Deed;" St. Charles, MO, St. Charles County Historical Society Archives, Street Address Files, "Handwritten Notes;" St. Charles, MO, St. Charles County Historical Society Archives, Street Address Files, "Research on 1005 Jefferson St.;" St. Charles, MO, St. Charles County Historical Society Archives, Street Address Files, "Wise, Taryn. The Oliver Link House of 1892-1896;" Brenda Rubach, "1005 Jefferson," Architectural/Historic Inventory Form, Stored at Missouri Cultural Resources Inventory, Missouri Historic Preservation Program. Jefferson City, Missouri, December, 2011; Interview with Thomas O. and Patricia Kuypers, St. Charles, Missouri, 20 December, 2012.

National Register of Historic Places  
Continuation Sheet

Section number 8 Page 7

Link, Oliver L. and Catherine, House
Name of Property
St. Charles, MO
County and State
N/A
Name of multiple listing (if applicable)

trim. Besides these first floor principal rooms, the rest of the house, including the dining room, originally had pine floors and utilized space on the second story for servants' quarters.

Link's propensity for technical innovation led him to install a large water storage tank in the maid's room with a pump in the basement to collect rain water from the roof. The house has a gas fireplace in the reception hall (the rest of the fireplaces were coal burning). Link also later installed electricity in the house and even installed fire alarms that are still in the house. Later, Link's son, Warren, who was a flower lover, built a fruit cellar and large wooden boxes in the basement to store bulbs. Circular shelving radiates around the walls under the tower in the basement, which is enclosed as a storage room for Mrs. Link's home preserved foods (utilizing another turn-of-the-century technological innovation—improved Mason jars and pressurized canning methods).<sup>4</sup>

After the completion of the house, Oliver L. and Catherine Link occupied the house together until Oliver's death in 1942, after which Catherine Link continued to live in the house until her own death in 1952. Their son Warren Link, who had been listed as a resident in the house since 1938 in city directories, continued to live in the house through at least 1952, but the house was vacant by 1955. By 1957, Harold L. Silvermann, a manager at Shear's Department Store, and his wife Kathleen lived in the house as renters, but by 1959 it was occupied by Floyd E. Wimberly, a pipeline contractor, and his wife, Hazel. The Wimberly family had moved by 1961 when the house was empty, although Raymond L. Barnes Jr., an engineer with the state highway department, and his wife Elizabeth, a teacher, had purchased the house that year. Raymond died by 1964 but Elizabeth and her son Robert, a student, continued to live in the house through 1967. In 1968 the house was sold to Davis, Ohlms and Hannegan, a business that purchased the house as an investment. The Oliver L. and Catherine Link House was vacant in 1969 then rented by Newton G. and Margie Summers, who only lived in the house in 1970 before it was left vacant in 1971. By 1972, Robert Schoffer rented the house and remained through 1976 before the property was sold to Michael T. and Mary L. Doyle, who worked for the St. Louis County government and owned the house until the current owners, Thomas and Patricia Kuypers, purchased the building in 1984.<sup>5</sup>

## OLIVER L. LINK

<sup>4</sup> Ibid., St. Charles, MO, St. Charles County Historical Society Archives, Baue Funeral Home Records, "Link, Oliver Louis;" St. Charles, MO, St. Charles County Historical Society Archives, St. Charles Midtown Community Association, "Midtown Historical Marker Application;" St. Charles, MO, St. Charles County Historical Society Archives, Obituaries, Addendum With Index Book 2, "Link, Oliver."

<sup>5</sup> *Walker's St. Charles Directory* (St. Charles, MO: George B. Walker, 1891); *Moore's Standard Directory and Reference Book of St. Charles, Missouri* (New York City: S. H. Moore Company, 1908-1909); *R. E. Hackman and Co.'s St. Charles City and St. Charles County Directory* (Quincy, IL: R. E. Hackman & Co., 1906, 1910, 1916-1917, 1918-1919); *St. Charles City Directory* (Peoria, IL: Leshnick Directory Co, 1921-1922); *Polk's St. Charles City Directory* (Chicago: R. L. Polk & Co., Compilers, 1925-1976).

National Register of Historic Places  
Continuation Sheet

Section number 8 Page 8

Link, Oliver L. and Catherine, House
Name of Property
St. Charles, MO
County and State
N/A
Name of multiple listing (if applicable)

Oliver Louis Link was born in Ambler, Pennsylvania on September 9, 1861. He moved to St. Charles in 1885 and married his wife Catherine Hugg in 1890. The Link's had four children, two daughters, Pearl, born in 1892, and Olive born in 1895, and two sons, Warren, born in 1898, and LeRoy, who died as a child.<sup>6</sup>

After moving to St. Charles, Link worked in a variety of positions for the St. Charles Car Manufacturing Company (which later became the American Car and Foundry Company) and he was first listed in the 1891-1892 city directories as an "employee" although he is thought to have already worked for the company prior to moving to work at the St. Charles plant from Pennsylvania. By 1906 (the next available city directory), he was listed as a foreman for the American Car and Foundry Company and by the time of his death, his obituaries described him as a foreman in a variety of the metal departments who later became a long-time executive with the company. During his time at the American Car and Foundry Company, Link also worked as an inventor and innovator. He received at least seven patents for new train car parts. Link invented the "Link Door" (which is still in use today to couple train cars), new styles of water coolers, a buffing mechanism for diaphragm faceplates, and an ash pan for coal trains, among other patented inventions relating to the train industry.<sup>7</sup>

In addition to his work at the American Car and Foundry Company, Link was also a leader in St. Charles' civic community. Link worked with the water department for a time (while still working for the American Car and Foundry Company) and was first elected to the city council in 1895. Link was re-elected in 1909 and 1928, serving a total of nineteen (non-consecutive) years as a member of the city council before retiring from the office in 1936 after having a cerebral hemorrhage. He died February 8, 1942, of another cerebral hemorrhage.<sup>8</sup>

## AMERICAN CAR AND FOUNDRY COMPANY

<sup>6</sup> St. Charles, MO, Baue Funeral Home Records, "Link, Oliver Louis;" St. Charles, MO, Obituaries, Addendum With Index Book 2, "Link, Oliver;" Kuypers "1005 Jefferson;" St. Charles, MO, "Midtown Historical Marker Application."

<sup>7</sup> Ibid; St. Charles, MO, St. Charles County Historical Society Archives, Street Address Files; "O. Link and A. Schnedler Ash Pan Patented Feb. 9, 1904;" "Upper Buffing Mechanism for the Diaphragm Face Plates," Google Patents [Website], Available at: [www.Google./Patent%20US1704394%20%20UPPER%20BUFFING%20MECHANISM%20FOR%20THE%20DIAPHRAGM%20FACE%20PLATES%20%20Google%20Patents.htm#v=onepage&q&f=false](http://www.Google./Patent%20US1704394%20%20UPPER%20BUFFING%20MECHANISM%20FOR%20THE%20DIAPHRAGM%20FACE%20PLATES%20%20Google%20Patents.htm#v=onepage&q&f=false), Accessed 10 October, 2012; "Water Cooler," Google Patents [Website], Available at: [www.Google/Patent%20US1909288%20-%20WATER%20COOLER%20-%20Google%20Patents.htm#v=onepage&q&f=false](http://www.Google/Patent%20US1909288%20-%20WATER%20COOLER%20-%20Google%20Patents.htm#v=onepage&q&f=false), Accessed 10 October, 2012.

<sup>8</sup> Ibid, St. Charles, MO, Baue Funeral Home Records, "Link, Oliver Louis;" St. Charles, MO, Obituaries, Addendum With Index Book 2, "Link, Oliver."

National Register of Historic Places  
Continuation Sheet

Section number 8 Page 9

Link, Oliver L. and Catherine, House
Name of Property
St. Charles, MO
County and State
N/A
Name of multiple listing (if applicable)

The St. Charles Car Manufacturing Company was founded in St. Charles, Missouri in 1873 and changed its name to the St. Charles Car Company around 1880. The company expanded into building passenger cars as well as freight cars in 1886 and became part of the American Car and Foundry Company when that company was founded in 1899 with the merger of thirteen railroad equipment companies around the country. In the following years, the company added five more railroad car companies and continued to expand its presence in the market. The American Car and Foundry Company quickly became one of the leaders in the train car construction industry and its St. Charles plant was one of its largest, which was retained and expanded after the series of mergers that formed the American Car and Foundry Company.<sup>9</sup>

After the consolidation of the American Car and Foundry Company, the St. Charles plant focused almost exclusively on passenger equipment, including baggage cars, baggage-mail cars, coaches, dining cars and business cars, although the factory did produce sleeper cars after World War II. During World War I, the company made escort wagons and parts for artillery vehicles. During World War II, the company converted to war time production and turned out more than 1,800 light tanks while simultaneously constructing specialized hospital cars at the rate of one per day by late 1944.<sup>10</sup>

After World War II, the company initially expanded, but as the 1950s continued, declines in passenger train service began to impact the American Car and Foundry Company. The company changed its name to ACF Industries in 1954, since the company had already diversified beyond railroad cars. In 1959, the manufacturing operations in St. Charles were phased out as the last of the passenger cars were shipped out, then in 1963, after the Berwick, Pennsylvania plant closed, St. Charles became the headquarters for the Amcar division of the company. In 1972, the Shippers Car Line, which was responsible for the sale of all types of rail cars to shippers other than railroad companies, as well as international sales, relocated its headquarters from New York City to St. Charles. The marketing and research departments of both divisions were closely tied and were eventually merged in 1984 after the company was acquired by Carl Icahn. The newly formed company retained its headquarters in St. Charles and the ACF headquarters, the engineering hub for all of the company's railcar building business, and the company's technical center all remain in St. Charles today.<sup>11</sup>

## ARCHITECTURE

<sup>9</sup> Edward S. Kaminski, *American Car and Foundry Company: A Centennial History 1899-1999* (Wilton, CA: Signature Press, 1999), 18-19.

<sup>10</sup> Ibid, 19.

<sup>11</sup> Ibid, 19-20.

National Register of Historic Places  
Continuation Sheet

Section number 8 Page 10

Link, Oliver L. and Catherine, House
Name of Property
St. Charles, MO
County and State
N/A
Name of multiple listing (if applicable)

The Oliver L. and Catherine Link House is the one of only three Richardsonian Romanesque style houses in Midtown St. Charles. The Richardsonian Romanesque style was named for H. H. Richardson, a leading architect, in the early 1880s, as a subtype of the Romanesque Revival style. Henry Hobson Richardson was born in Louisiana in 1838 and after attending Harvard became the second American to study at the Ecole des Beaux-Arts in Paris, returning to the United States after the Civil War and opening an office in New York. By the 1870s, Richardson had moved his offices to Boston where he designed homes and buildings in the Second Empire, Queen Anne and Stick styles that were predominant in the late 1860s and the 1870s. In 1879-1880, Richardson designed the rectory for Trinity Church in Boston, his first Romanesque design house. Over the next few years, Richardson designed a few more Richardsonian Romanesque houses, including examples in St. Louis, but his early death in 1886 limited the number of houses he was able to design. The style did not immediately gain traction, but shortly after Richardson's death, a monograph on his work was published in 1888, which gave the style a wider audience and increased interest in it.<sup>12</sup>

Richardsonian Romanesque houses, by the nature of the design were almost exclusively made from brick or stone. The increased cost of such construction meant that the majority of Richardsonian Romanesque style houses were architect-designed. As such, it was a style that was used less frequently than other styles in the late nineteenth century and only on some of the more notable houses in a community. Examples of the style are scattered throughout the United States, but the majority are in the northeastern states that were most accessible to Richardson's original work and his successor firm. The style was strongly based in traditional Romanesque style but also incorporated elements of Gothic Revival, Syrian arches, and some Queen Anne elements. This blending of styles into a Romanesque form lends itself to a style typified by full arches, usually with decorative surrounds, which often spring from heavy brick or stone piers, especially to highlight the entrances. There is typically a heavily massed tower on the corner of the building and hipped roofs with cross gables, often with dormers. The windows are also often arched and also typically have heavy stone or brick surrounds.<sup>13</sup>

The house, which was designed by Oliver Link himself, is a three-story (including the attic) yellow brick building with the heavy massing typical of Richardsonian Romanesque design, especially through the use of extensive stone detailing, including heavy stone arches above the west side entry and the window that mirrors it. The building also has moderately pitched hipped roof that flares out slightly at the bottom creating wider eaves and further increasing the apparent massing of the building. The roof has intersecting cross-gables on the side elevations and a central dormer on the front façade, also typical of Richardsonian Romanesque design. The tower

<sup>12</sup> Virginia McAlester and Lee McAlester, *A Field Guide to American Houses* (New York: Alfred A Knopf, 2000), 302.

<sup>13</sup> Ibid.



National Register of Historic Places  
Continuation Sheet

Section number 8 Page 11

Link, Oliver L. and Catherine, House
Name of Property
St. Charles, MO
County and State
N/A
Name of multiple listing (if applicable)

has continuous sill stone courses and there are stone sills for the other windows. One of the few details that is not typical of a Richardsonian Romanesque design is that the windows are not set as deeply as is typical for the style, but the recessed entry maintains the sense of mass and solidity typical of the style.

The Oliver L. and Catherine Link House is one of the most architecturally distinct houses in St. Charles. In the recent survey of Mid-Town St. Charles neighborhood, the Oliver L. and Catherine Link House was one of only twenty-four properties out of the 569 surveyed that were suggested for individual listing in the National Register of Historic Places.<sup>14</sup> The house is also one of only three Richardsonian Romanesque houses that have been identified in the Midtown neighborhood. The Link House is in a neighborhood that has a large variety of high style residential designs, including examples of Federal, Italianate, Queen Anne, Colonial Revival, Craftsman, Tudor Revival and Ranch styles.<sup>15</sup> The majority of the houses in the immediate area were constructed between 1900 and 1930, making the Oliver L. and Catherine Link House one of the older homes.<sup>16</sup> Besides the varied high style designs in the area, there are also numerous vernacular designs, including Front Gable, Side Gable, I-House, American Four Square, Bungalows, and Gable Front and Wing.<sup>17</sup>

## CONCLUSION

As one of three Richardsonian Romanesque houses in the entire neighborhood, the Oliver L. and Catherine Link House is a distinctive house even within a neighborhood where there are a number of notable designs, although most of the other notable designs are from the 1920s and 1940s.<sup>18</sup> The use of the Richardsonian Romanesque style adds a sense of mass and stability to the Oliver L. and Catherine Link House that defines the style and makes the house more visually arresting than the other houses in the surrounding neighborhood.

The Oliver L. and Catherine Link House is also the building most closely associated with the life of Oliver L. Link. Not only did Link design the house himself, after its completion he lived in the house until his death in 1942. Link incorporated innovative designs into the home, a fire alarm system, a system to store and pump rain water, and a gas fireplace as well as being early to

<sup>14</sup> Brenda S. Rubach, *Phase 2 Architectural/ Historical Survey of the Mid-Town and Commons Neighborhoods, St. Charles, MO* (St. Charles, MO: City of St. Charles, 2012), 53. Karen Bode Baxter and Ruth Keenoy, *Architectural/ Historical Survey of the Mid-Town and Commons Neighborhoods, St. Charles, MO* (St. Charles, MO: City of St. Charles, 2011), 10-11. This figure was confirmed with Brenda Rubach as she was working to finish Phase 3 of the survey of Mid-Town and the Commons Neighborhoods.

<sup>15</sup> Ibid, 38.

<sup>16</sup> Ibid.

<sup>17</sup> Ibid, 7.

<sup>18</sup> Ibid, 53.

National Register of Historic Places  
Continuation Sheet

Section number 8 Page 12

Link, Oliver L. and Catherine, House
Name of Property
St. Charles, MO
County and State
N/A
Name of multiple listing (if applicable)

adapt electricity into his home. Besides his work at the largest employer in St. Charles, the American Car and Foundry Company, Link was also an important part of the St. Charles community, working as an elected official with the city council for many years. He also worked with the water department in St. Charles in addition to his work at the American Car and Foundry Company and with the city council. Oliver O. Link's innovative work and the numerous patented inventions he designed for the American Car and Foundry Company, including the "Link Door" which is known to still be in use today, helped him rise to an executive position with the largest business in St. Charles. It also afforded him the opportunity to aid his community through his work on the city council and with the water department. The combination of these factors make Oliver O. Link an important person in the history of St. Charles and the Oliver O. and Catherine Link House, which Oliver Link designed himself and lived in from its completion until his death, is closely associated with Link's life and is a visible and tangible reminder of the impact he had on the community.

National Register of Historic Places  
Continuation Sheet

Section number 9 Page 13

Link, Oliver L. and Catherine, House
Name of Property
St. Charles, MO
County and State
N/A
Name of multiple listing (if applicable)

**Bibliography**

“AHDEHSON.” Google Patents [Website] Available at: <http://www.google.com/patents/US1265686?pg=PA2&dq=%22oliver+l.+link%22&hl=en#v=onepage&q=%22oliver%20l.%20link%22&f=false>. Accessed 10 October, 2012.

Baxter, Karen and Ruth Keenoy, *Architectural/ Historical Survey of the Mid-Town and Commons Neighborhoods, St. Charles, MO*. St. Charles, Missouri: City of St. Charles, 2011.

Bates, Fraysen. *Progressive St. Charles*. St. Charles, Missouri: St. Charles Chamber of Commerce, 1916.

Blumenson, John J-G. *Identifying American Architecture: A Pictorial Guide to Styles and Terms*, 2<sup>nd</sup> ed. Nashville, TN: American Association for State and Local History, 1981.

“Cooler.” Google Patents [Website] Available at: <http://www.google.com/patents/US1205096?pg=PA2&dq=%22oliver+l.+link%22&hl=en#v=onepage&q=%22oliver%20l.%20link%22&f=false>. Accessed 10 October, 2012.

“Fire Insurance Map of St. Charles, Missouri.” New York: Sanborn Map Company, 1893.

“Fire Insurance Map of St. Charles, Missouri.” New York: Sanborn Map Company, 1900.

“Fire Insurance Map of St. Charles, Missouri.” New York: Sanborn Map Company, 1909.

“Fire Insurance Map of St. Charles, Missouri.” New York: Sanborn Map Company, 1917.

“Fire Insurance Map of St. Charles, Missouri.” New York: Sanborn Map Company, 1929.

“Fire Insurance Map of St. Charles, Missouri.” New York: Sanborn Map Company, 1929, corrected to 1947.

Kaminski, Edward S. *American Car and Foundry Company: A Centennial History 1899-1999*. Wilton, California: Signature Press, 1999.

Kuypers, Thomas O. and Patricia Kuypers. St. Charles, Missouri. Interview. 20 December, 2012.

McAlester, Virginia and Lee McAlester. *A Field Guide to American Houses*. New York: Alfred A Knopf, 2000.

*Moore's Standard Directory and Reference Book of St. Charles, MO*. New York: S. H. Moore Company, 1908-1909.

Olson, Edna McElhiney and Sperandio, Richard G. *McElhiney's Guide Book of Historic St. Charles, MO*. St. Charles, Missouri: McElhiney Publishing Company, 1993.

Olson, Edna McElhiney. *Historical St. Charles, Missouri*. St. Charles, Missouri: Self Published, 1967.

National Register of Historic Places  
Continuation Sheet

Section number 9 Page 14

Link, Oliver L. and Catherine, House
Name of Property
St. Charles, MO
County and State
N/A
Name of multiple listing (if applicable)

- Polk's St. Charles City Directory. 1925-1926.* [Chicago: R. L. Polk & Co., Compilers] Peoria, IL: Leshnick Directory Co., Publishers, 1925.
- Polk's St. Charles (Missouri) City Directory. 1927-1928.* Chicago: R. L. Polk & Co., 1927-1928.
- Polk's St. Charles (Missouri) City Directory. 1929-1930.* Chicago: R. L. Polk & Co., 1929-1930.
- Polk's St. Charles (Missouri) City Directory. 1931-1932.* Chicago: R. L. Polk & Co., 1931-1932.
- Polk's St. Charles (St. Charles County, Missouri) City Directory. 1936.* Chicago: R. L. Polk & Co., 1936.
- Polk's St. Charles City Directory (St. Charles County, Missouri). 1939.* Chicago: R. L. Polk & Co., 1939.
- Polk's St. Charles City Directory (St. Charles County, Missouri). 1941.* Chicago: R. L. Polk & Co., 1941.
- Polk's St. Charles City Directory (St. Charles County, Missouri). 1942.* Chicago: R. L. Polk & Co., 1942.
- Polk's St. Charles City Directory (St. Charles County, Missouri). 1945.* Chicago: R. L. Polk & Co., 1945.
- Polk's St. Charles City Directory (St. Charles County, Missouri). 1948.* Chicago: R. L. Polk & Co., 1948.
- Polk's St. Charles City Directory (St. Charles County, Missouri). 1950.* Chicago: R. L. Polk & Co., 1950.
- Polk's St. Charles City Directory (St. Charles County, Missouri). 1952.* Chicago: R. L. Polk & Co., 1952.
- Polk's St. Charles City Directory (St. Charles County, Missouri). 1955.* Chicago: R. L. Polk & Co., 1955.
- Polk's St. Charles City Directory (St. Charles County, Missouri). 1957.* Chicago: R. L. Polk & Co., 1957.
- Polk's St. Charles City Directory (St. Charles County, Missouri). 1959.* Chicago: R. L. Polk & Co., 1959.
- Polk's St. Charles City Directory (St. Charles County, Missouri). 1961.* Chicago: R. L. Polk & Co., 1961.
- Polk's St. Charles City Directory (St. Charles County, Missouri). 1963.* Chicago: R. L. Polk & Co., 1963.

National Register of Historic Places  
Continuation Sheet

Section number 9 Page 15

Link, Oliver L. and Catherine, House
Name of Property
St. Charles, MO
County and State
N/A
Name of multiple listing (if applicable)

- Polk's St. Charles City Directory (St. Charles County, Missouri). 1964.* Chicago: R. L. Polk & Co., 1964.
- Polk's St. Charles City Directory (St. Charles County, Missouri). 1966.* Chicago: R. L. Polk & Co., 1966.
- Polk's St. Charles City Directory (St. Charles County, Missouri). 1967.* Chicago: R. L. Polk & Co., 1967.
- Polk's St. Charles City Directory (St. Charles County, Missouri). 1969.* Chicago: R. L. Polk & Co., 1969.
- Polk's St. Charles City Directory (St. Charles County, Missouri). 1970.* Chicago: R. L. Polk & Co., 1970.
- Polk's St. Charles City Directory (St. Charles County, Missouri). 1971.* Chicago: R. L. Polk & Co., 1971.
- Polk's St. Charles City Directory (St. Charles County, Missouri). 1972.* Chicago: R. L. Polk & Co., 1972.
- Polk's St. Charles City Directory (St. Charles County, Missouri). 1973.* Chicago: R. L. Polk & Co., 1974.
- Polk's St. Charles City Directory (St. Charles County, Missouri). 1975.* Chicago: R. L. Polk & Co., 1975.
- Polk's St. Charles City Directory (St. Charles County, Missouri). 1976.* Chicago: R. L. Polk & Co., 1976.
- Polk's St. Charles City Directory (St. Charles County, Missouri). 1977.* Chicago: R. L. Polk & Co., 1977.
- Polk's St. Charles City Directory (St. Charles County, Missouri). 1978.* Chicago: R. L. Polk & Co., 1978.
- Polk's St. Charles City Directory (St. Charles County, Missouri). 1979.* Chicago: R. L. Polk & Co., 1979.
- R. E. Hackman and Co.'s St. Charles City and St. Charles County Directory, 1906.* Quincy, Illinois: R. E. Hackman & Co., 1906.
- R. E. Hackman and Co.'s St. Charles City Directory, 1910.* Quincy, Illinois: R. E. Hackman & Co., 1910.
- R. E. Hackman and Co.'s St. Charles City Directory, 1916-17.* Quincy, Illinois: R. E. Hackman & Co., 1916-1917.
- R. E. Hackman and Co.'s St. Charles City Directory, 1918-19.* Quincy, Illinois: R. E. Hackman & Co., 1918-1919.

National Register of Historic Places  
Continuation Sheet

Section number 9 Page 16

Link, Oliver L. and Catherine, House
Name of Property
St. Charles, MO
County and State
N/A
Name of multiple listing (if applicable)

Rubach, Brenda S. *Phase 2 Architectural/ Historical Survey of the Mid-Town and Commons Neighborhoods, St. Charles, MO*. St. Charles, Missouri: City of St. Charles, 2012.

\_\_\_\_\_. "1005 Jefferson." Architectural/Historic Inventory Form. Stored at Missouri Cultural Resources Inventory, Missouri Historic Preservation Program. Jefferson City, MO. December, 2011.

*St. Charles City Directory. 1921-1922*. Peoria, Illinois: Leshnick Directory Co, 1921-1922.

St. Charles, Missouri. St. Charles County Historical Society Archives. Baue Funeral Home Records. "Link, Oliver Louis."

\_\_\_\_\_. St. Charles County Historical Society Archives. County Courthouse Files. "References to Lots/Madison."

\_\_\_\_\_. St. Charles County Historical Society Archives. Hollinger Box Floor 1. [Photo] "St. Charles City 'Officials ca 1899-1904.'"

\_\_\_\_\_. St. Charles County Historical Society Archives. Jean Zerr Collection. [Photo] "Seated: Catherine Haglin Holding Catherine; Dean Harvey, Warren F."

\_\_\_\_\_. St. Charles County Historical Society Archives. St. Charles Midtown Community Association. "Midtown Historical Marker Application."

\_\_\_\_\_. St. Charles County Historical Society Archives. Obituaries, Addendum With Index Book2. "Link, Oliver."

\_\_\_\_\_. St. Charles County Historical Society Archives. 1905 Plat Book.

\_\_\_\_\_. St. Charles County Historical Society Archives. County Courthouse Files. "Conveyance of front 10' to City of St. Charles."

\_\_\_\_\_. St. Charles County Historical Society Archives. County Courthouse Files. "Deed."

\_\_\_\_\_. St. Charles County Historical Society Archives. Street Address Files. "Handwritten Notes."

\_\_\_\_\_. St. Charles County Historical Society Archives. Street Address Files. "Copy of Title Insurance Policy."

\_\_\_\_\_. St. Charles County Historical Society Archives. Street Address Files. "House Tour 1983."

\_\_\_\_\_. St. Charles County Historical Society Archives. Street Address Files. "O. Link and A. Schnedler Ash Pan Patented Feb. 9, 1904."

\_\_\_\_\_. St. Charles County Historical Society Archives. Street Address Files. "Research on 1005 Jefferson St."

\_\_\_\_\_. St. Charles County Historical Society Archives. Street Address Files. "Their Dream House."

National Register of Historic Places  
Continuation Sheet

Section number 9 Page 17

Link, Oliver L. and Catherine, House
Name of Property
St. Charles, MO
County and State
N/A
Name of multiple listing (if applicable)

\_\_\_\_\_. St. Charles County Historical Society Archives. Street Address Files. "Wise, Taryn. The Oliver Link House of 1892-1896."

"Trap Door." Google Patents [Website] Available at: <http://www.google.com/patents/US1122514?pg=PA4&dq=%22oliver+l.+link%22&hl=en#v=onepage&q=%22oliver%20l.%20link%22&f=false>. Accessed 10 October, 2012.

"Upper Buffing Mechanism for the Diaphragm Face Plates." Google Patents [Website] Available at: [www.Google./Patent%20US1704394%20-%20UPPER%20BUFFING%20MECHANISM%20FOR%20THE%20DIAPHRAGM%20FACE%20PLATES%20-%20Google%20Patents.htm#v=onepage&q&f=false](http://www.Google./Patent%20US1704394%20-%20UPPER%20BUFFING%20MECHANISM%20FOR%20THE%20DIAPHRAGM%20FACE%20PLATES%20-%20Google%20Patents.htm#v=onepage&q&f=false). Accessed 10 October, 2012.

"Water Cooler." Google Patents [Website] Available at: [www.Google/Patent%20US1909288%20-%20WATER%20COOLER%20%20Google%20Patents.htm#v=onepage&q&f=false](http://www.Google/Patent%20US1909288%20-%20WATER%20COOLER%20%20Google%20Patents.htm#v=onepage&q&f=false). Accessed 10 October, 2012.

*Walker's St. Charles Directory*. St. Charles, Missouri: George B. Walker, 1891.

Whiffen, Marcus. *American Architecture Since 1780*. Revised ed. Cambridge, Massachusetts: The MIT Press, 1969.

National Register of Historic Places  
Continuation Sheet

Section number 10 Page 18

Link, Oliver L. and Catherine, House
Name of Property
St. Charles, MO
County and State
N/A
Name of multiple listing (if applicable)

**Verbal Boundary Description**

A parcel of land identified as a private alley (Book 135 at page 74) in Block 266, City of St. Charles, St. Charles, County, Missouri and being more particularly described as follows:

Commencing at the Northeasterly corner of said Block 266; thence Southerly along the Easterly line of said Block 266 a distance of 150.00 feet to the true point of beginning of the hereinafter described parcel of land; thence Southerly along said Easterly line a distance of 39.09 feet to the Southeasterly corner of said private alley; thence Westerly along the Southerly line of said private alley a distance of 100.00 feet to the Southerly extension of the Westerly line of land now or formerly of Thomas O. Kuypers et ux; thence Northerly along said extension a distance of 39.09 feet to the Southwesterly corner of said Kuypers land; thence Easterly along the Southerly line of said Kuypers land a distance of 100.00 feet to the true point of beginning and containing an area of 0.09 acres (based upon existing record information, and private survey by others) as per calculations by Bax Engineering Company, Inc., June, 1987.

**Boundary Justification**

These boundaries incorporate all of the property that has been historically associated with this house and the property's legal description.



National Register of Historic Places  
Continuation Sheet

Section number Figures Page 19

Link, Oliver L. and Catherine, House
Name of Property
St. Charles, MO
County and State
N/A
Name of multiple listing (if applicable)

Figure 1: Map Locating Property

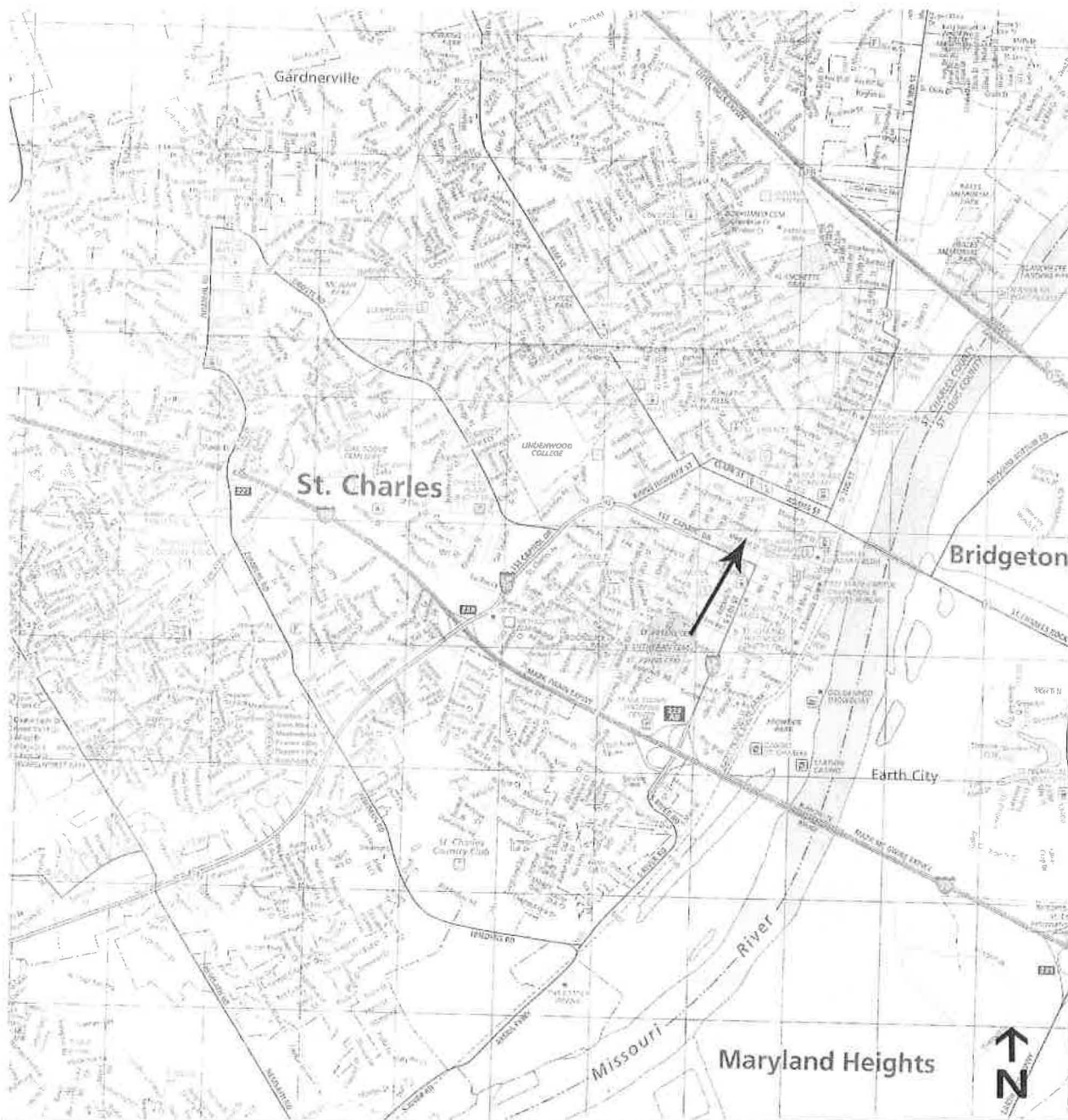

National Register of Historic Places  
Continuation Sheet

Section number Figures Page 20

Link, Oliver L. and Catherine, House
Name of Property St. Charles, MO
County and State N/A
Name of multiple listing (if applicable)

Figure 2: 1905 Plat Book of St. Charles County, Missouri  
Courtesy of St. Charles County Historical Society

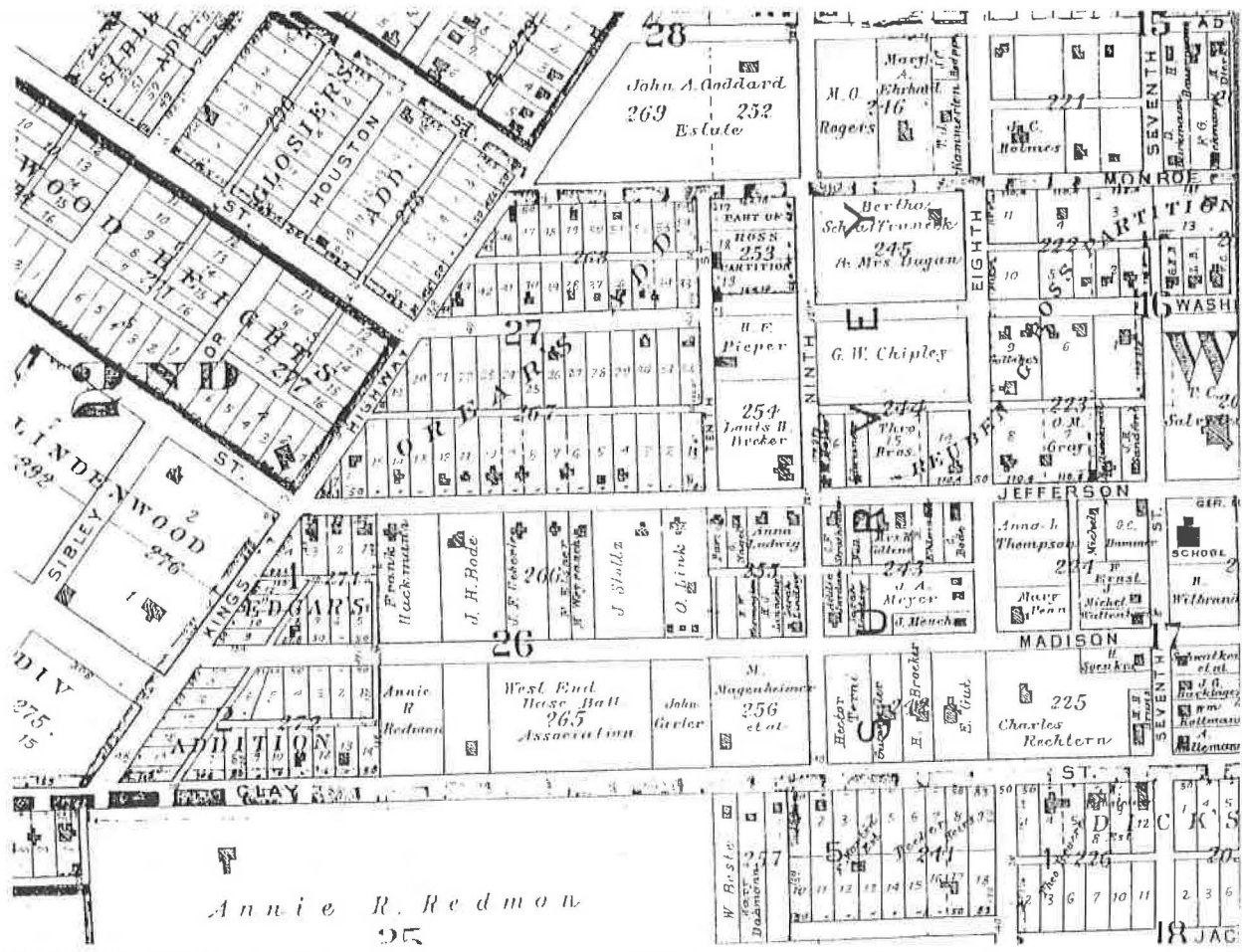

National Register of Historic Places  
Continuation Sheet

Section number Figures Page 21

Link, Oliver L. and Catherine, House
Name of Property
St. Charles, MO
County and State
N/A
Name of multiple listing (if applicable)

Figure 3: 1909 Sanborn Map

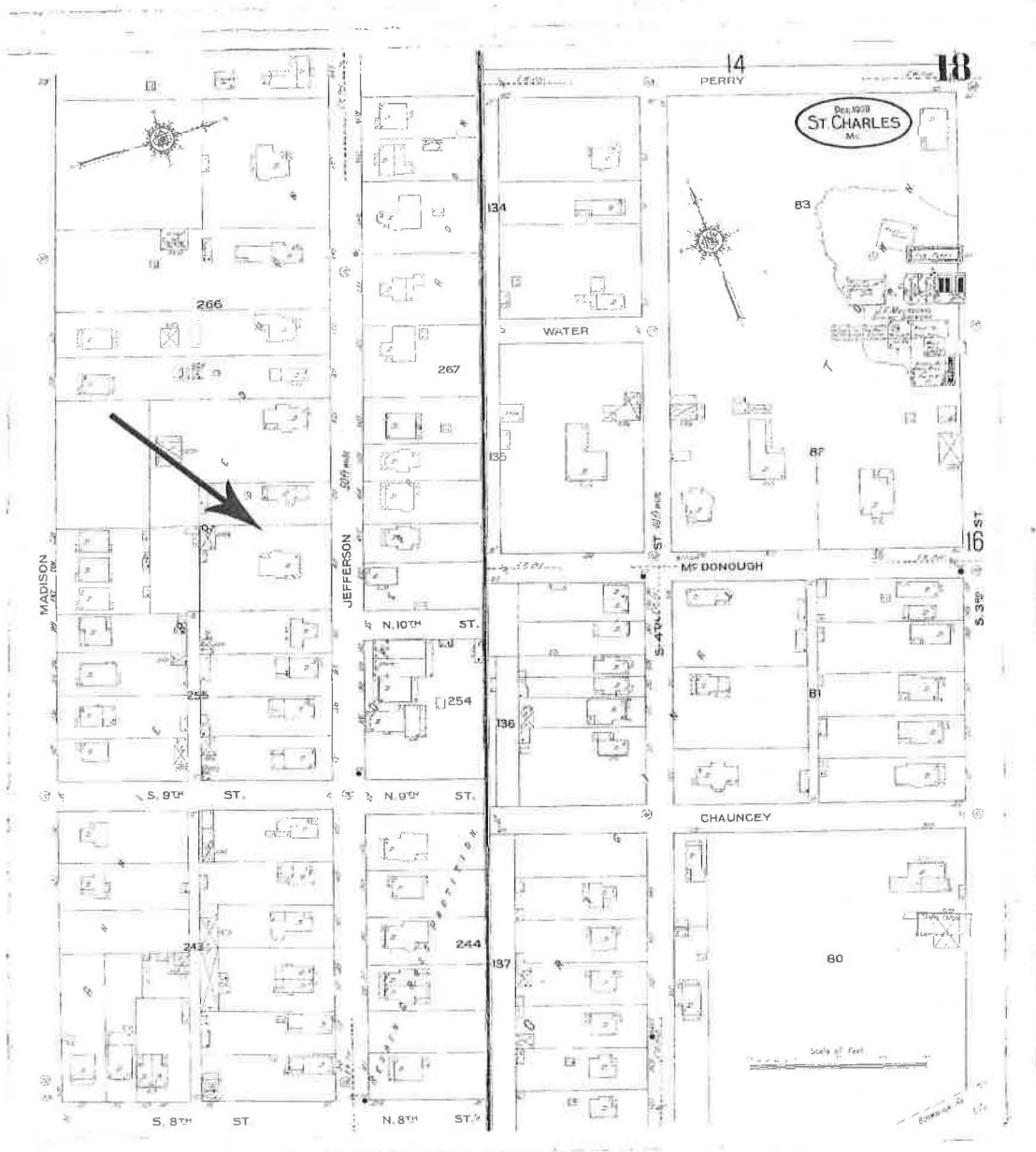

National Register of Historic Places  
Continuation Sheet

Section number Figures Page 22

Link, Oliver L. and Catherine, House
Name of Property
St. Charles, MO
County and State
N/A
Name of multiple listing (if applicable)

Figure 4: 1917 Sanborn Map

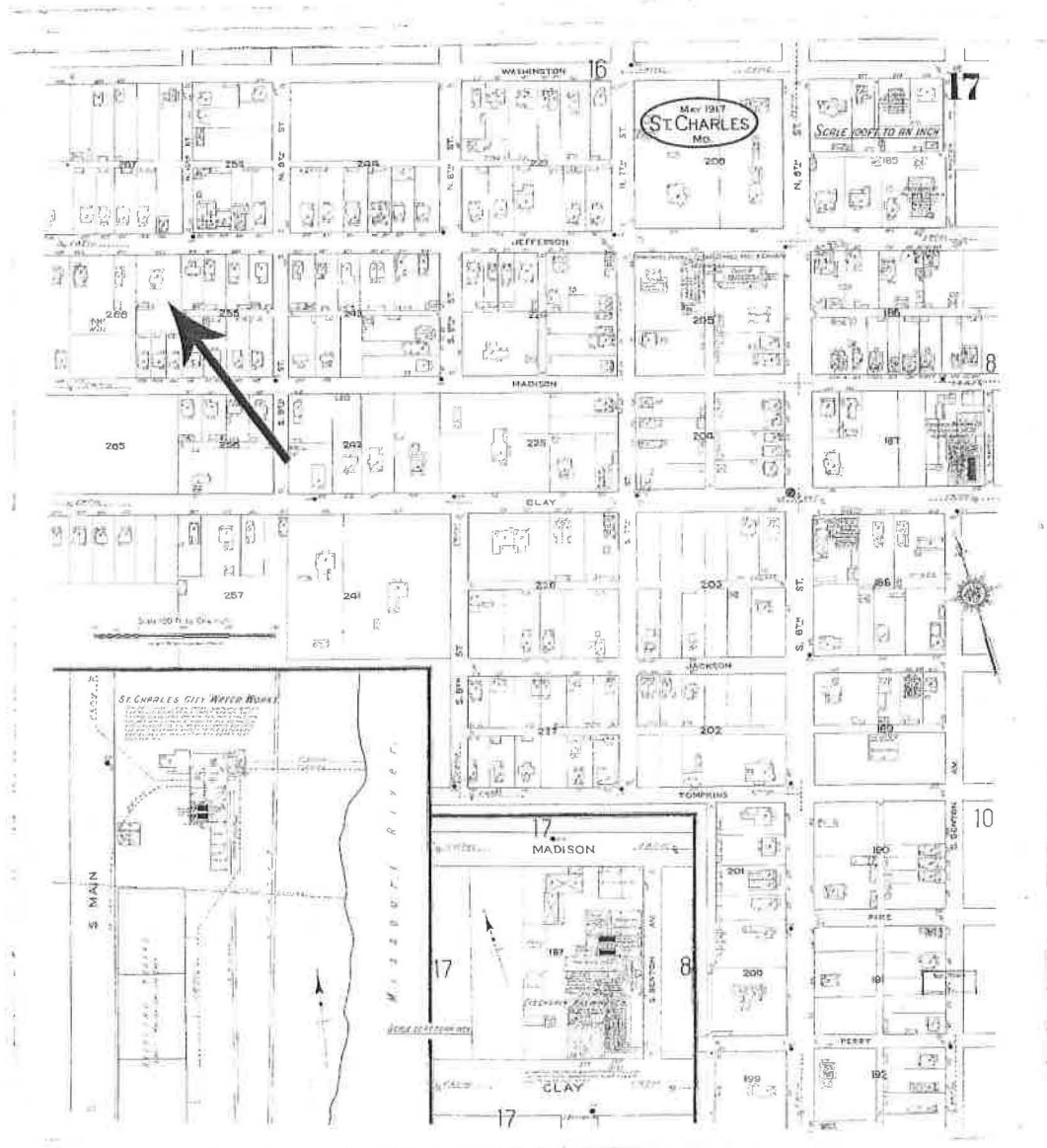

National Register of Historic Places  
Continuation Sheet

Section number Figures Page 23

Link, Oliver L. and Catherine, House
Name of Property
St. Charles, MO
County and State
N/A
Name of multiple listing (if applicable)

Figure 5: 1929 Sanborn Map

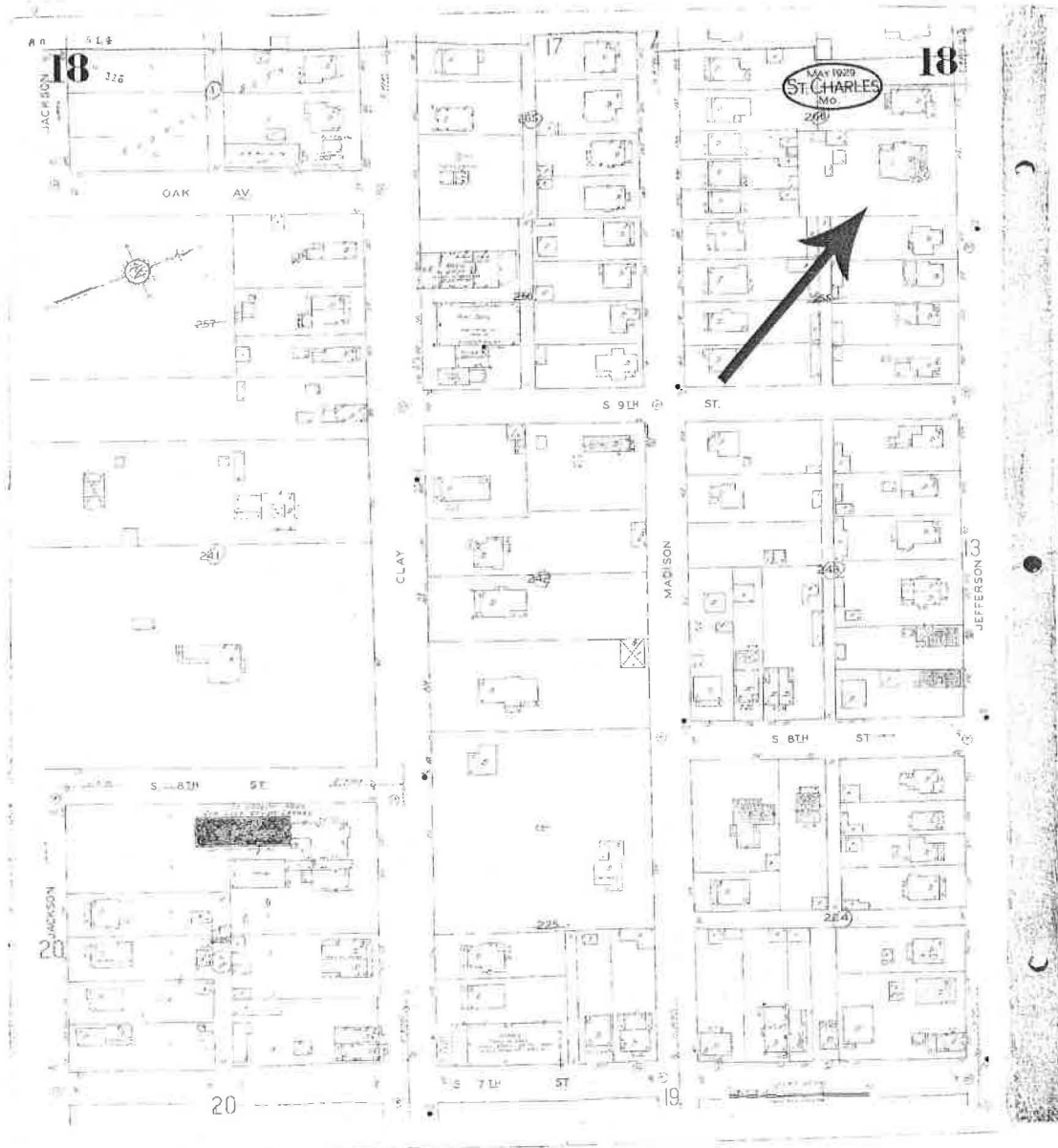

National Register of Historic Places  
Continuation Sheet

Section number Figures Page 24

Link, Oliver L. and Catherine, House
Name of Property
St. Charles, MO
County and State
N/A
Name of multiple listing (if applicable)

**Figure 6: Basement Floor Plan**  
**Drawn by Patricia Kuypers**

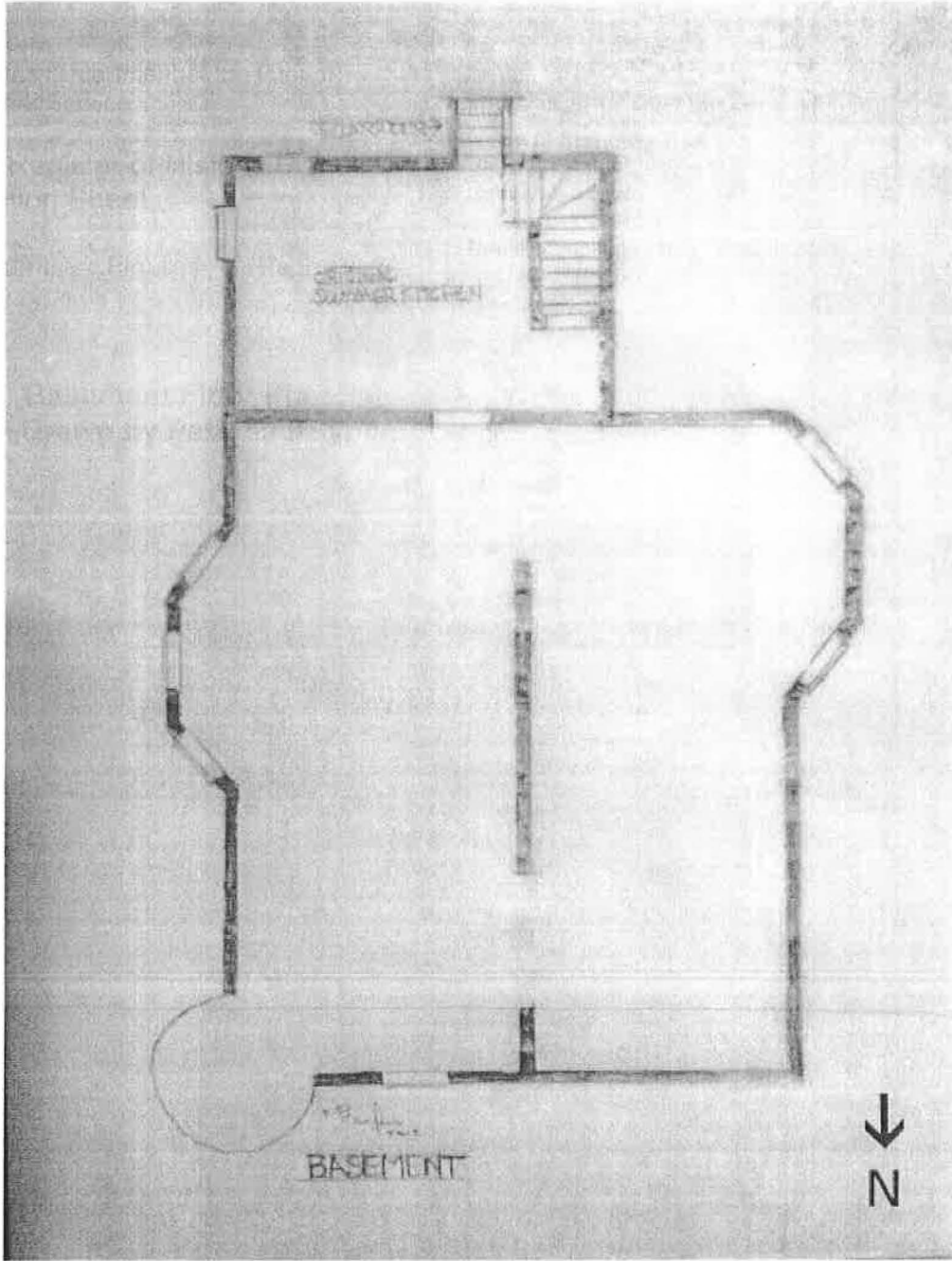

National Register of Historic Places  
Continuation Sheet

Section number Figures Page 25

Link, Oliver L. and Catherine, House
Name of Property
St. Charles, MO
County and State
N/A
Name of multiple listing (if applicable)

**Figure 7: First Floor Plan**  
**Drawn by Patricia Kuypers**

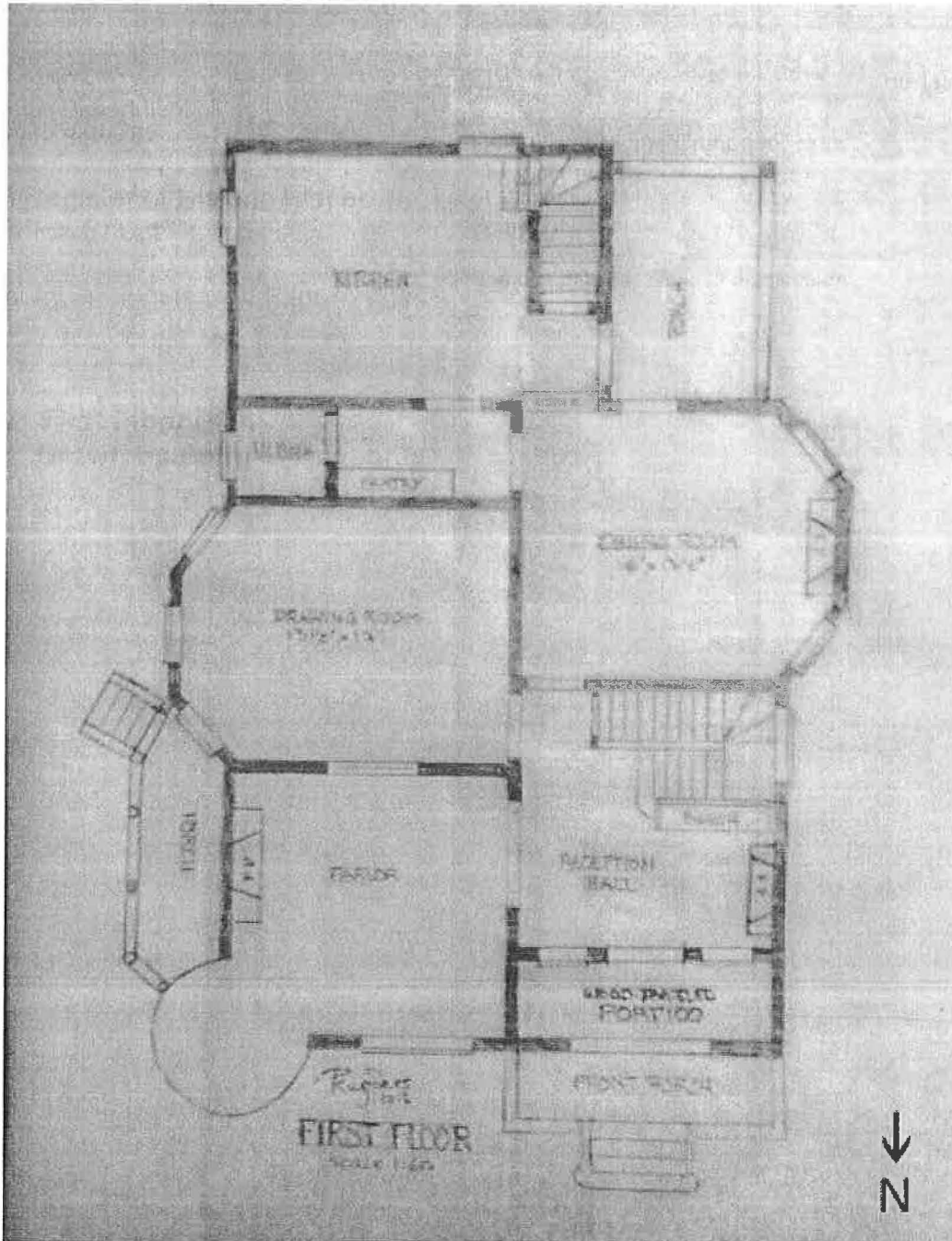

National Register of Historic Places  
Continuation Sheet

Section number Figures Page 26

Link, Oliver L. and Catherine, House
Name of Property
St. Charles, MO
County and State
N/A
Name of multiple listing (if applicable)

**Figure 8: Second Floor Plan**  
Drawn by Patricia Kuypers

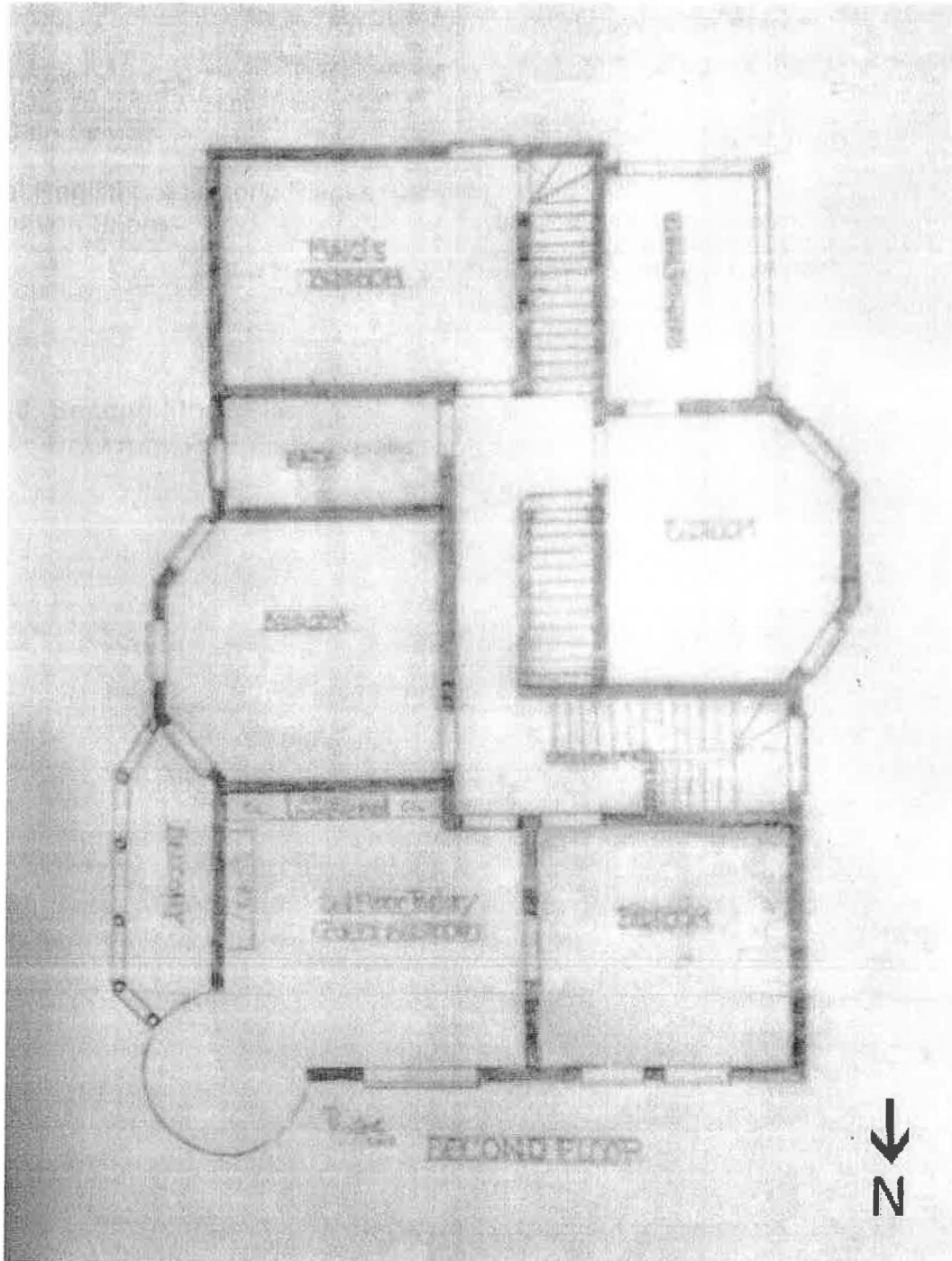



National Register of Historic Places  
Continuation Sheet

Section number Figures Page 27

Link, Oliver L. and Catherine, House
Name of Property
St. Charles, MO
County and State
N/A
Name of multiple listing (if applicable)

**Figure 9: Attic Floor Plan**  
Drawn by Patricia Kuypers

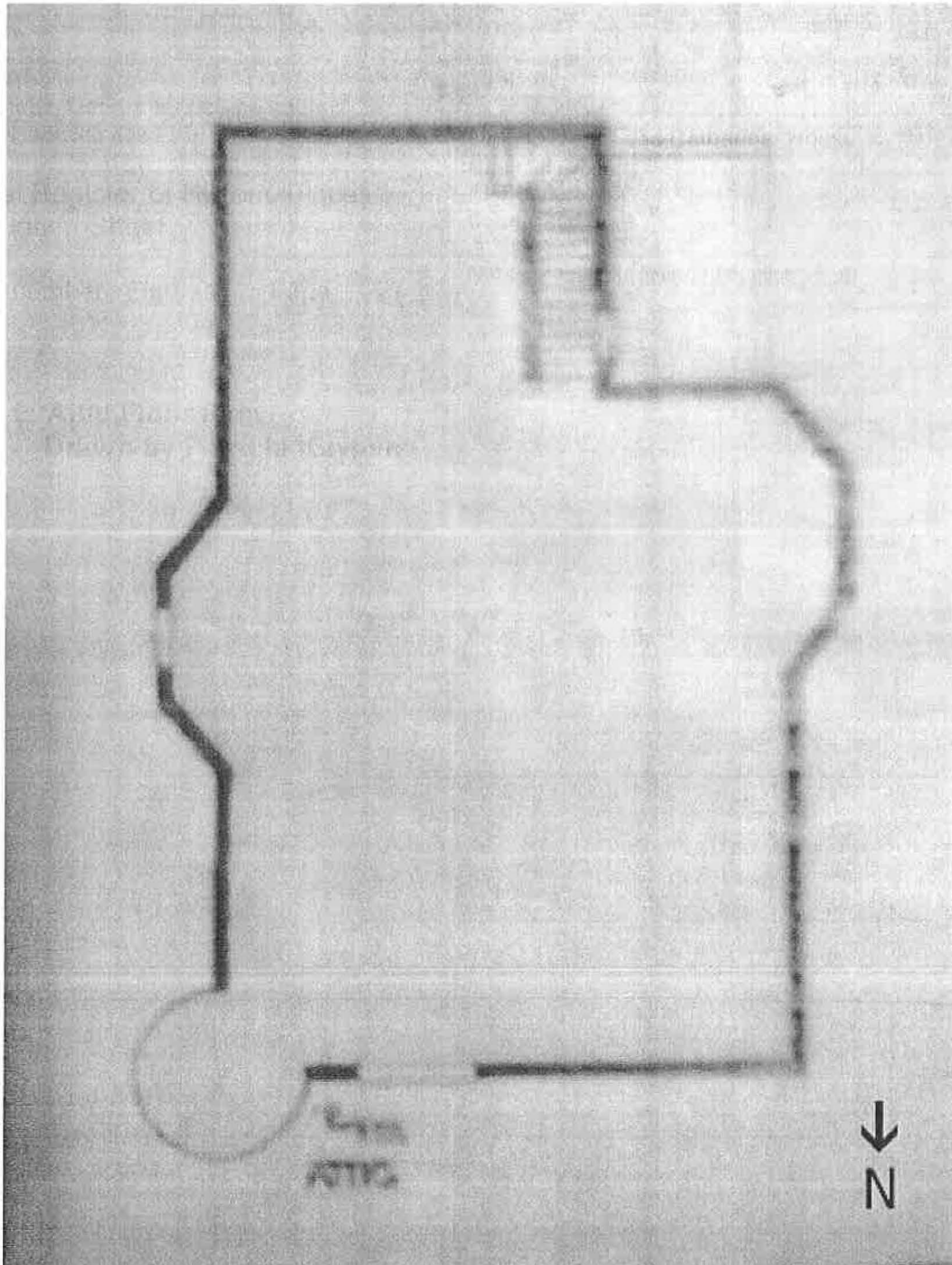

National Register of Historic Places  
Continuation Sheet

Section number Figures Page 28

Link, Oliver L. and Catherine, House
Name of Property
St. Charles, MO
County and State
N/A
Name of multiple listing (if applicable)

Figure 10: St. Charles City Officials with Mayor ca. 1899-1904  
Courtesy of St. Charles County Historical Society

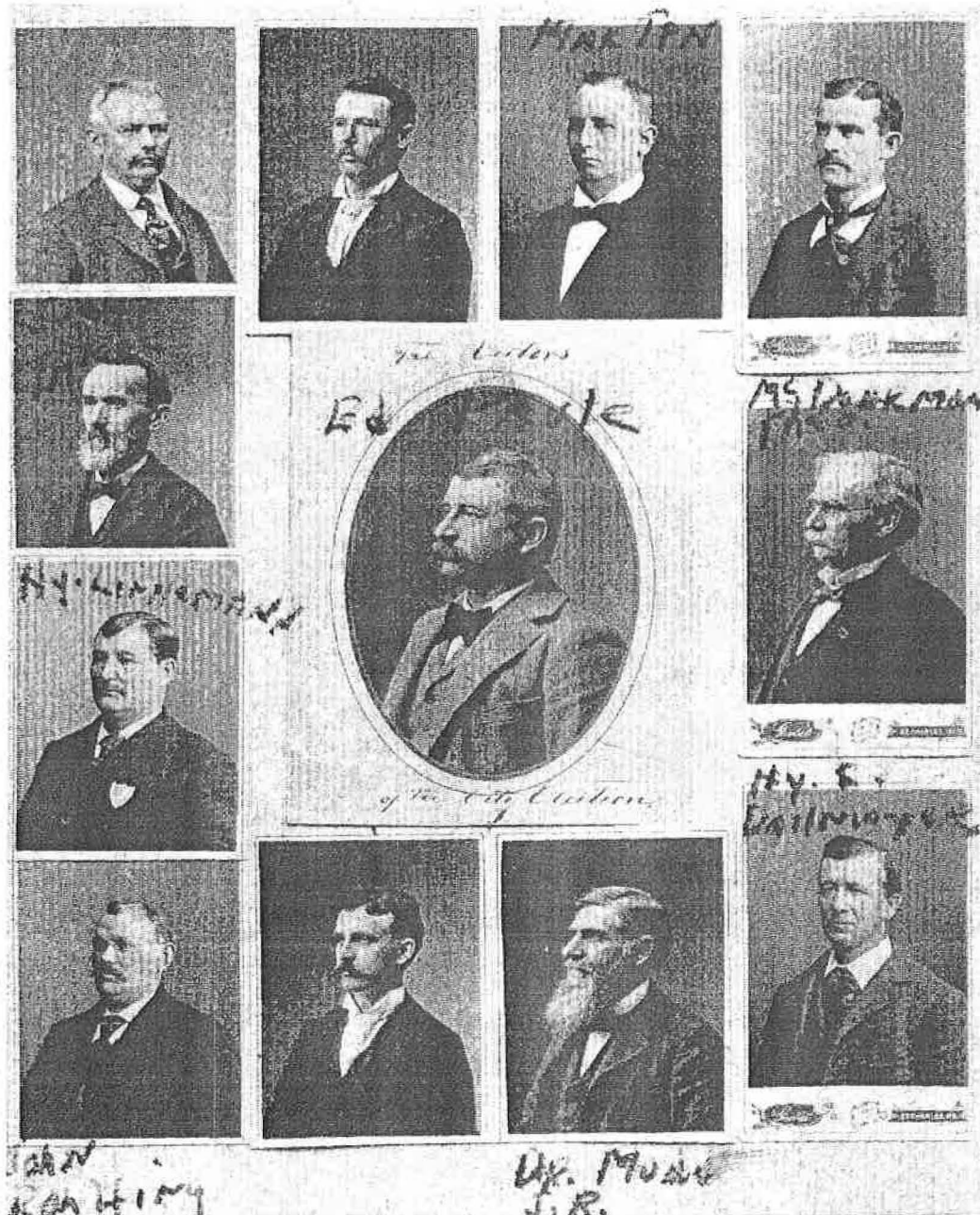

National Register of Historic Places  
Continuation Sheet

Section number Figures Page 29

Link, Oliver L. and Catherine, House
Name of Property
St. Charles, MO
County and State
N/A
Name of multiple listing (if applicable)

**Figure 11: Oliver Link Family Photo ca. 1917**  
**Courtesy of St. Charles County Historical Society**



National Register of Historic Places  
Continuation Sheet

Section number      Figures      Page   30  

Link, Oliver L. and Catherine, House
Name of Property
St. Charles, MO
County and State
N/A
Name of multiple listing (if applicable)

**Figure 12: Photo of the American Car and Foundry Company in St. Charles  
Olson, Edna McElhiney. *Historical St. Charles, Missouri*. St. Charles,  
Missouri: Self Published, 1967.**

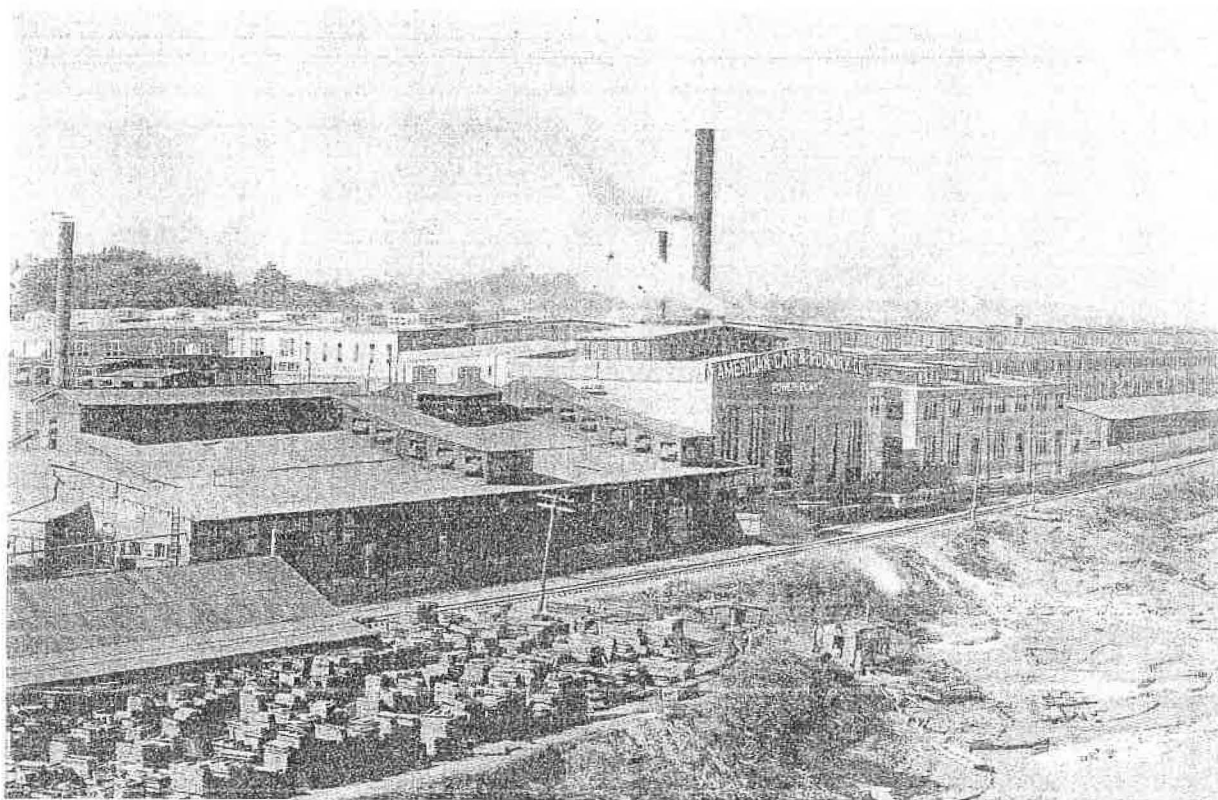

National Register of Historic Places  
Continuation Sheet

Section number Figures Page 31

Link, Oliver L. and Catherine, House
Name of Property
St. Charles, MO
County and State
N/A
Name of multiple listing (if applicable)

Figure 13: Oliver Link Patent for the Ash Pan  
Printed from "AHDEHSOH." Google Patents [Website]

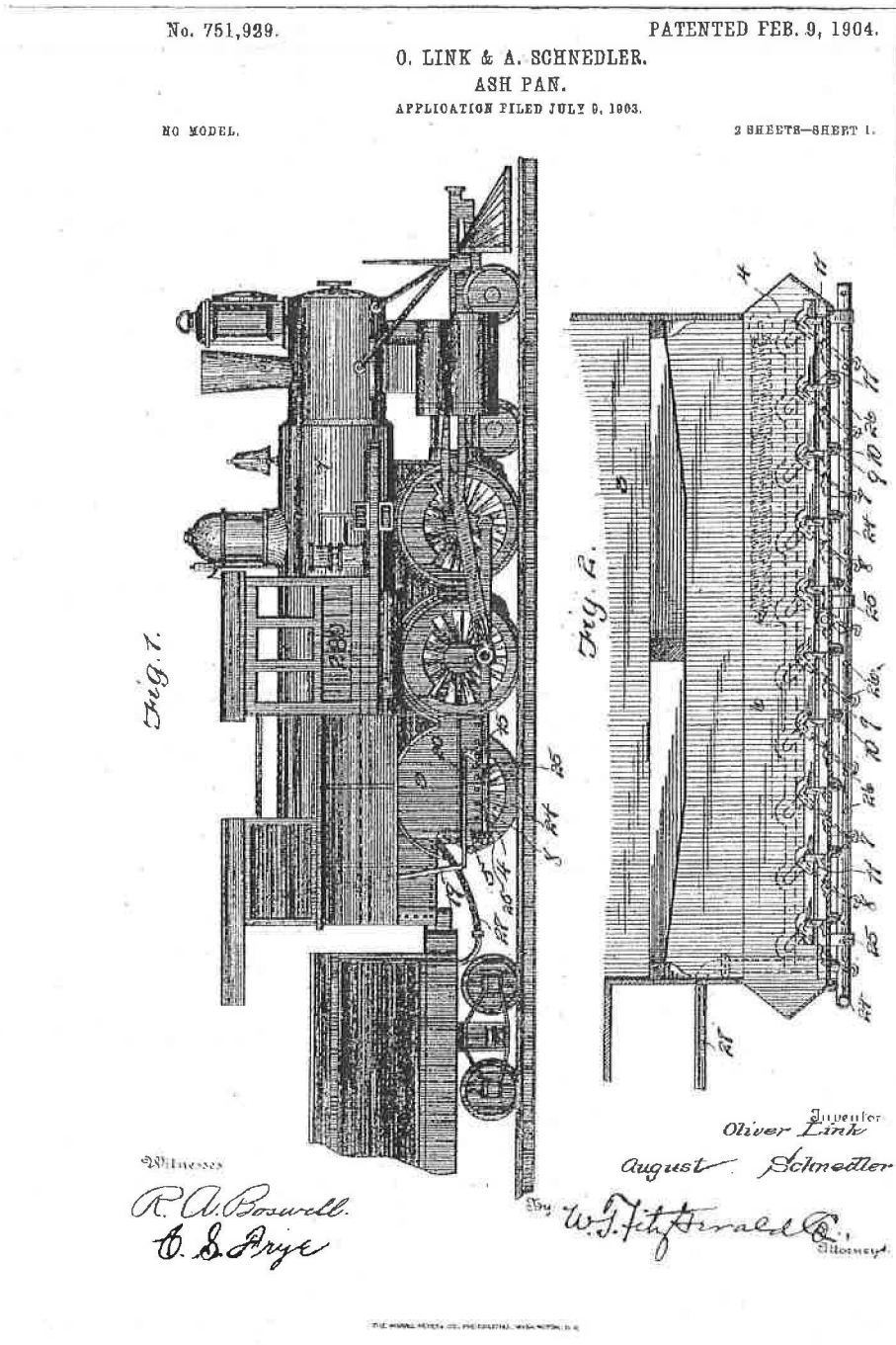

National Register of Historic Places  
Continuation Sheet

Section number Figures Page 32

Link, Oliver L. and Catherine, House
Name of Property
St. Charles, MO
County and State
N/A
Name of multiple listing (if applicable)

**Figure 14: Oliver Link Patent for the Water Cooler**  
Printed from "AHDEHSOH." Google Patents [Website]

May 16, 1933.

O. L. LINK  
WATER COOLER

1,909,288

Filed Sept. 29, 1930

2 Sheets-Sheet 1

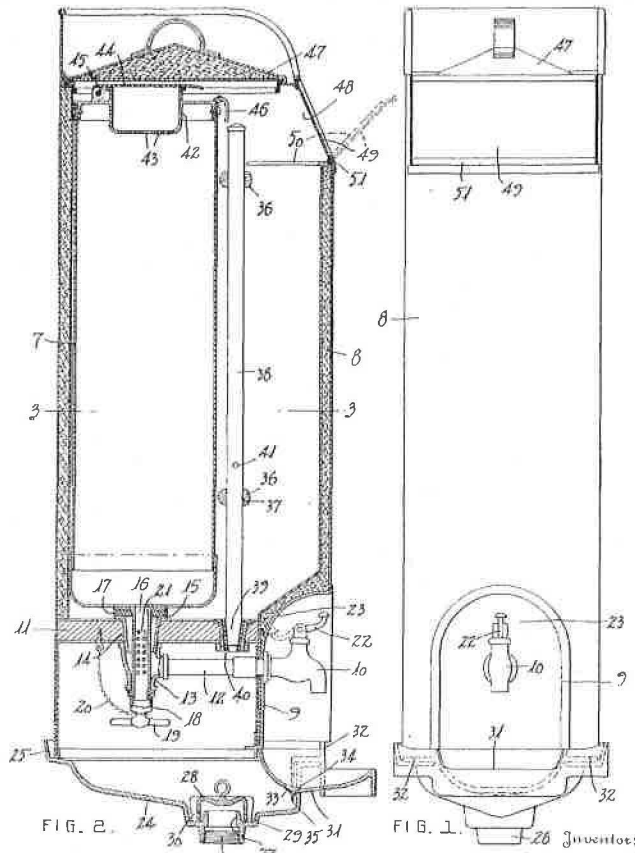

FIG. 2.

FIG. 1.

Oliver L. Link  
Inventor:  
Howard C. Miller  
Attorney

National Register of Historic Places  
Continuation Sheet

Section number Figures Page 33

Link, Oliver L. and Catherine, House
Name of Property
St. Charles, MO
County and State
N/A
Name of multiple listing (if applicable)

**Figure 15: Oliver Link Patent for the Cooler**  
Printed from "AHDEHSOH." Google Patents [Website]

O. L. LINK.  
COOLER.  
APPLICATION FILED NOV. 5, 1913.  
1,205,096. Patented Nov. 14, 1916.

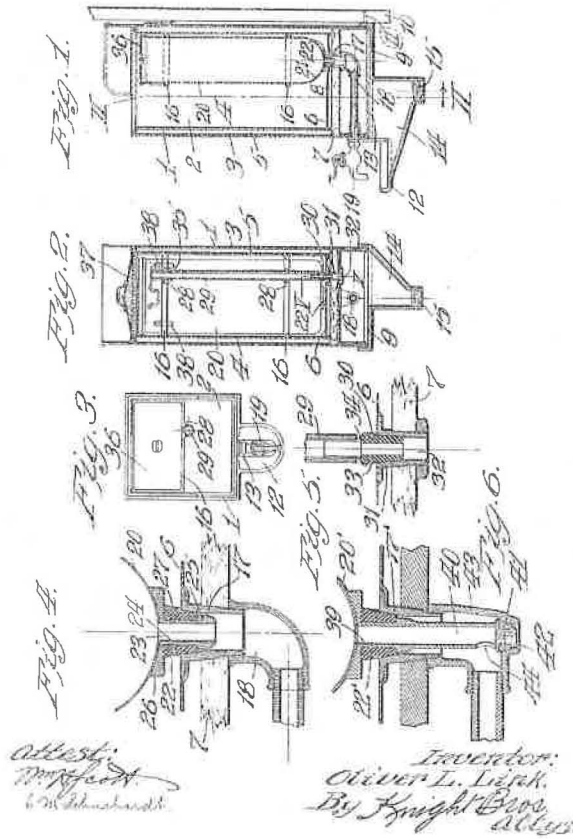

National Register of Historic Places  
Continuation Sheet

Section number Figures Page 34

Link, Oliver L. and Catherine, House
Name of Property
St. Charles, MO
County and State
N/A
Name of multiple listing (if applicable)

**Figure 16: Oliver Link Patent for the Upper Buffing Mechanism  
Printed from "AHDEHSOH." Google Patents [Website]**

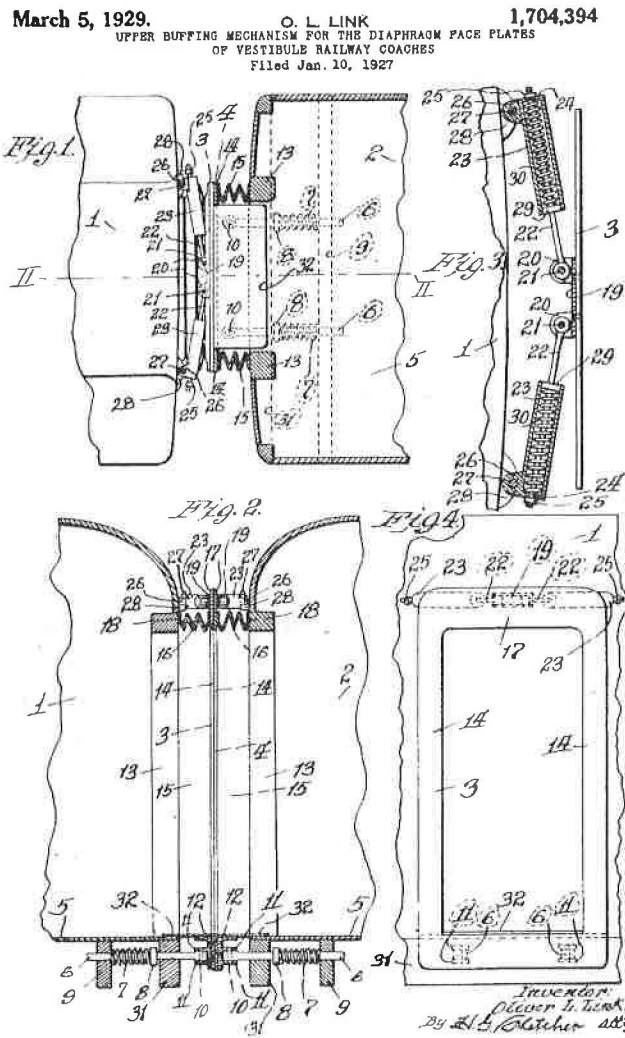



National Register of Historic Places  
Continuation Sheet

Section number Figures Page 35

Link, Oliver L. and Catherine, House
Name of Property
St. Charles, MO
County and State
N/A
Name of multiple listing (if applicable)

**Figure 17: Oliver Link Patent for the Trap Door**  
Printed from "AHDEHSON." Google Patents [Website]

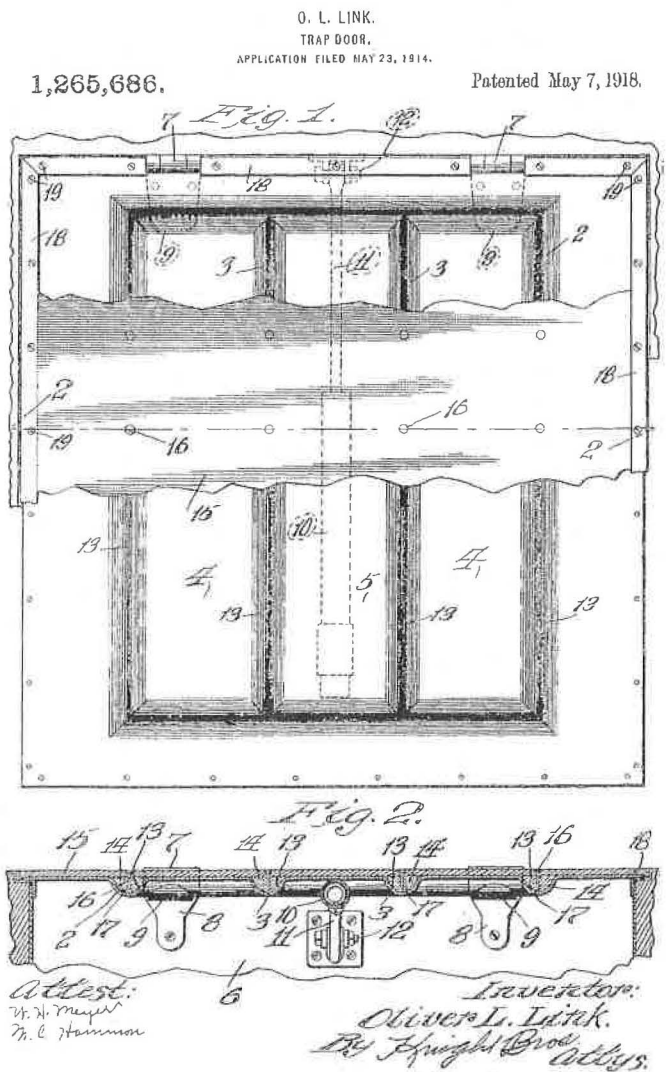

National Register of Historic Places  
Continuation Sheet

Section number Figures Page 36

Link, Oliver L. and Catherine, House
Name of Property
St. Charles, MO
County and State
N/A
Name of multiple listing (if applicable)

**Figure 18: Oliver Link Patent for the Trap Door**  
Printed from "AHDEHSOH." Google Patents [Website]

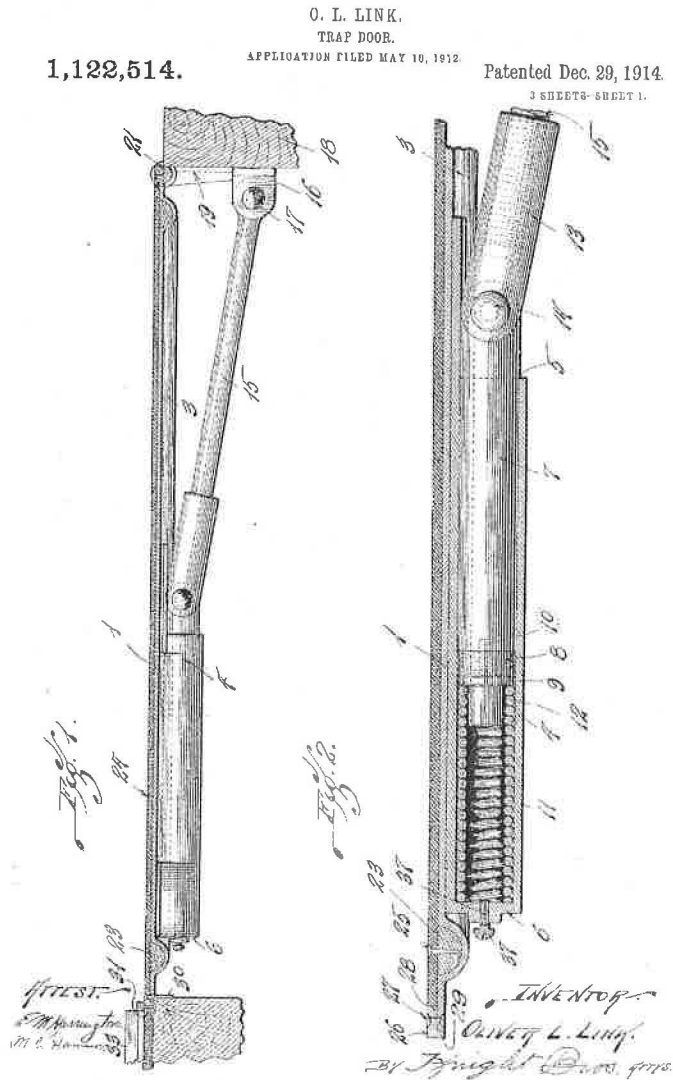



Link Oliver L. and Catherine, Hoxe  
15/717 775/4295 660 T 47 N

Produced by the United States Geological Survey

Compiled by photogrammetric methods from imagery dated 1952  
Field checked 1954. Revised from imagery dated 1990 and  
and other sources. Field checked 1993. Map edited 1994

North American Datum of 1927 (NAD 27). Projection and  
blue 1000-meter ticks: Universal Transverse Mercator, zone 15  
10 000-foot ticks: Missouri coordinate system, east zone

North American Datum of 1983 (NAD 83) is shown by dashed  
corner ticks. The values of the shift between NAD 27 and NAD 83  
for 7.5-minute intersections are obtainable from National Geodetic  
Survey NADCON software

There may be private inholdings within the boundaries of  
the National or State reservations shown on this map

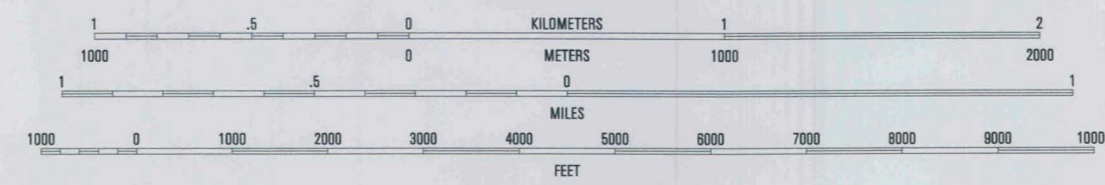
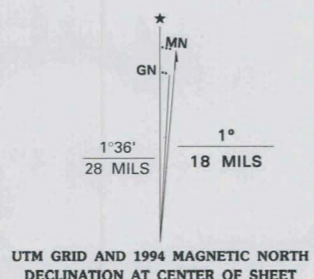

CONTOUR INTERVAL 10 FEET  
NATIONAL GEODETIC VERTICAL DATUM OF 1929

COMPLIES WITH U.S. GEOLOGICAL SURVEY STANDARDS FOR SPATIAL ACCURACY - CLASS 2  
FOR SALE BY U.S. GEOLOGICAL SURVEY, DENVER, COLORADO 80225, OR RESTON, VIRGINIA 22092  
AND DIVISION OF GEOLOGY AND LAND SURVEY  
MISSOURI DEPARTMENT OF NATURAL RESOURCES, ROLLA, MISSOURI 65401  
A FOLDER DESCRIBING TOPOGRAPHIC MAPS AND SYMBOLS IS AVAILABLE ON REQUEST

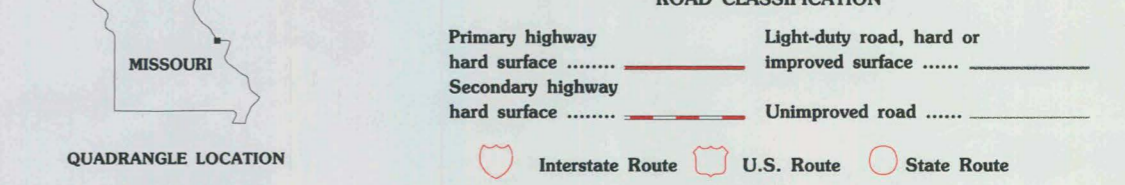

QUADRANGLE LOCATION

1	2	3	1 Brussels
4	5	6	2 Grafton
7	8	9	3 Elsie
			4 Elsie
			5 Florissant
			6 Chesterfield
			7 Creve Coeur
			8 Clayton

ST. CHARLES, MO.  
38090-G4-TF-024

1994

DMA 7961 IV SW - SERIES V879









1005























UNITED STATES DEPARTMENT OF THE INTERIOR  
NATIONAL PARK SERVICE

NATIONAL REGISTER OF HISTORIC PLACES  
EVALUATION/RETURN SHEET

REQUESTED ACTION: NOMINATION

PROPERTY NAME: Link, Oliver L. and Catherine, House

MULTIPLE NAME:

STATE & COUNTY: MISSOURI, St. Charles

DATE RECEIVED: 6/21/13      DATE OF PENDING LIST: 7/22/13  
DATE OF 16TH DAY: 8/06/13      DATE OF 45TH DAY: 8/07/13  
DATE OF WEEKLY LIST:

REFERENCE NUMBER: 13000584

REASONS FOR REVIEW:

APPEAL: N    DATA PROBLEM: N    LANDSCAPE: N    LESS THAN 50 YEARS: N  
OTHER: N    PDIL: N    PERIOD: N    PROGRAM UNAPPROVED: N  
REQUEST: N    SAMPLE: N    SLR DRAFT: N    NATIONAL: N

COMMENT WAIVER: N

ACCEPT     RETURN     REJECT    8.6.13 DATE

ABSTRACT/SUMMARY COMMENTS:

**Entered in  
The National Register  
of  
Historic Places**

RECOM./CRITERIA \_\_\_\_\_

REVIEWER \_\_\_\_\_ DISCIPLINE \_\_\_\_\_

TELEPHONE \_\_\_\_\_ DATE \_\_\_\_\_

DOCUMENTATION see attached comments Y/N see attached SLR Y/N

If a nomination is returned to the nominating authority, the nomination is no longer under consideration by the NPS.

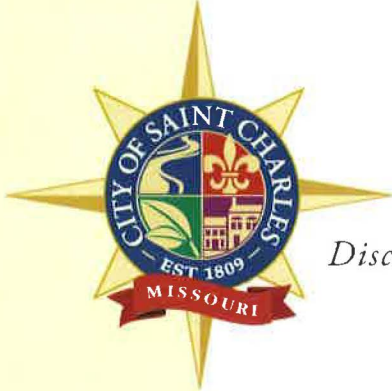

*Discover.*

March 19, 2013

RECEIVED

MAR 22 2013

STATE HISTORIC  
PRESERVATION OFFICE

Mr. Mark A. Miles, Director and Deputy  
State Historic Preservation Officer  
Missouri Department of Natural Resources  
P.O. Box 176  
Jefferson City, MO 65102

Dear Mr. Miles:

RE: Oliver L. and Catherine Link House, 1005 Jefferson Street, St. Charles

Enclosed is the Missouri CLG National Register of Historic Places Nomination Review Report Form for the Oliver L. and Catherine Link House at 1005 Jefferson Street in St. Charles. The City's Landmarks Board reviewed the nomination at its March 18, 2013, meeting and determined that the house retains historic integrity and is individually eligible for listing in the National Register for both historic and architectural significance. However, the Board requests that a few corrections be made.

In several places in the Statement of Significance the Link House is referred to as the only example of the Richardsonian Romanesque style in the Mid-Town Neighborhood; however, there are two other examples, including the Pieper House at 125 North Fifth Street and the Atkinson House at 620 Jefferson Street. Also, in Section 8 it is said that the majority of the houses in the neighborhood were constructed between 1900 and 1930, making the Link House one of the oldest homes in the neighborhood. This is not correct. These statements are based on information found in the survey report for phase 2 of the three-phased survey of the Mid-Town Neighborhood. In phases 1-3 of the survey of the neighborhood nearly 80 houses were identified that were built prior to 1890 and many others were built in the 1890s, like the Link House.

Thank you for the opportunity to comment on the nomination. If you have any questions, please do not hesitate to contact me at 636-949-3228.

Sincerely,

Brenda S. Rubach  
Preservation Planner

enclosure

*Community Development*

Missouri CLG National Register of Historic Places  
Nomination Review Report Form

RECEIVED

MAR 22 2013

STATE HISTORIC  
PRESERVATION OFFICE

Property Name: Oliver L. and Catherine Link House  
Address: 1005 Jefferson, St. Charles, St. Charles County  
Certified Local Government: Landmarks Board of St. Charles  
Date of public meeting at which nomination was reviewed: March 18, 2013

**Criteria of Significance** Please check below the responses appropriate to the nomination review.  
NOTE: For more information on the criteria, see *National Register Bulletin: How to Apply the National Register Criteria for Evaluation*.

- Criterion A. Property is associated with events that have made a significant contribution to our history.
- Criterion B. Property is associated with the lives of persons significant in our past.
- Criterion C. Property embodies the distinctive characteristics of a type, period or method of construction, or represents a work of a master, or possesses high artistic values, or represents a significant and distinguishable entity whose components may lack individual distinction (a district).
- Criterion D. Property has yielded or may be likely to yield information important in prehistory or history.
- None of the Above

**Integrity** Please check below the responses appropriate to the nomination review.  
NOTE: For more information on integrity, see *National Register Bulletin: How to Apply the National Register Criteria for Evaluation*.

- The property retains authentic historic character from its period of significance.
- The property has been significantly altered and no longer retains authentic historic character from its period of significance.

**Review Comments** Please check below the responses appropriate to the nomination review.

*Commission/Board*

- The commission/board recommends that the property is significant, retains integrity and is eligible for listing in the National Register of Historic Places. *Corrections needed - see attached sheet.*
- The commission/board recommends that the property does not meet the criteria of significance and/or no longer retains integrity and is not eligible for listing in the National Register of Historic Places.
- The commission/board chooses not to make a recommendation on the nomination. An explanation of the lack of a recommendation is attached.

*Chief Elected Official*

- The chief elected official recommends that the property is significant, retains integrity and is eligible for listing in the National Register of Historic Places.
- The chief elected official recommends that the property does not meet the criteria of significance and/or no longer retains integrity and is not eligible for listing in the National Register of Historic Places.
- The chief elected official chooses not to make a recommendation on the nomination. An explanation of the lack of a recommendation is attached.

**Attach additional sheets for further comments.**

*CLG Commission/Board Chair or Representative*

Print Name: John Hanneke, Vice Chairperson, Landmarks Board

Signature and Date: John Hanneke, 3-18-2013

*Chief Elected Official or Designee*

Print Name: SALLYA FAITH, MAYOR

Signature and Date: Sallya Faith 3/19/13

### **Link House, 1005 Jefferson Street, St. Charles, MO**

The Landmarks Board determined that the Link House is historically and architecturally significant, retains historic integrity, and that the nomination contains sufficient information to document the significance and integrity of the property. However, several corrections are needed. In several places in the Statement of Significance the consultants state that the house is the only example of the Richardsonian Romanesque style of architecture in the Mid-Town Neighborhood; however, there are two other examples, including the Pieper House at 125 North Fifth Street and the Atkinson House at 620 Jefferson Street. Also, the statement is made that the majority of the houses in the neighborhood were constructed between 1900 and 1930, making the Link House one of the oldest homes in the neighborhood. Actually, the majority of the houses in *phase 2* of the survey of the neighborhood were constructed during that period, but in Mid-Town as a whole (phases 1-3 of the survey), nearly 80 houses were identified that were built prior to 1890 and many others were built in the 1890s, like the Link House.

RECEIVED 2280

JUN 21 2013

NAT. REGISTER OF HISTORIC PLACES  
NATIONAL PARK SERVICE



Jeremiah W. (Jay) Nixon, Governor • Sara Parker, Auditor

# DEPARTMENT OF NATURAL RESOURCES

www.dnr.mo.gov

## Memorandum

**Date:** June 13, 2013

**To:** Keeper, National Register of Historic Places

**From:** Mark A. Miles, Deputy SHPO and Director, Missouri State Historic Preservation Office *MAM*

**Subject:** Link, Oliver L. and Catherine, House, St. Charles, St. Charles County, Missouri, National Register Nomination

Our state review board, the Missouri Advisory Council on Historic Preservation, approved the above nomination on May 9, 2013. All owners and appropriate elected public officials were notified and provided at least thirty (30) days to comment on the above nomination in accordance with Section 36CFR60.6, interim regulations, using the exact notification format recommended by the National Register.

Please find enclosed the following documentation:

- 1   Original National Register of Historic Places registration form
- Multiple Property Documentation Form
- 13   Photographs
- 2   CD with electronic images
- 1   Original USGS map(s)
- Sketch map(s)/figures(s)/exhibits not on continuation sheets
- 2   Piece(s) of correspondence (cover letter)
- Other: \_\_\_\_\_

### Comments:

- Please insure that this nomination is reviewed
- The enclosed owner objection(s) do        do not        constitute a majority of property owners.
- Other: \_\_\_\_\_