

HISTORIC PROPERTIES INVENTORY FORM

HISTORIC PRESERVATION UNIT  
DEPARTMENT OF CULTURE & HISTORY  
THE CULTURAL CENTER  
CHARLESTON, WEST VIRGINIA 25305

(Staff Use Only)

File No:  
Theme(s):  
Neg No(s):  
USGS Quad:  
UTM Ref:  
See Item #/6

DISTRICT: SITE: BUILDING: STRUCTURE: OBJECT

- 1. NAME(S) historic/common: Hickory Hill  
*(South Branch MRA)*
- 2. LOCATION street/road: N/S US Route 220  
city/town: East of Petersburg, WV  
(incorporated/unincorporated)
- 3. USE/FUNCTION present: Private Residence/Agriculture  
(public/private, restricted)  
original: Private Residence/Agriculture
- 4. OWNER/ADDRESS present: Patricia Welton Garrot and  
Judith Welton Feinberg  
(public/private)  
original: Solomon Cunningham  
Moorefield, WV  
(phone no.)  
N/A
- 5. PHOTO/SKETCH OF:

7. PLAN (include approx. dimensions):

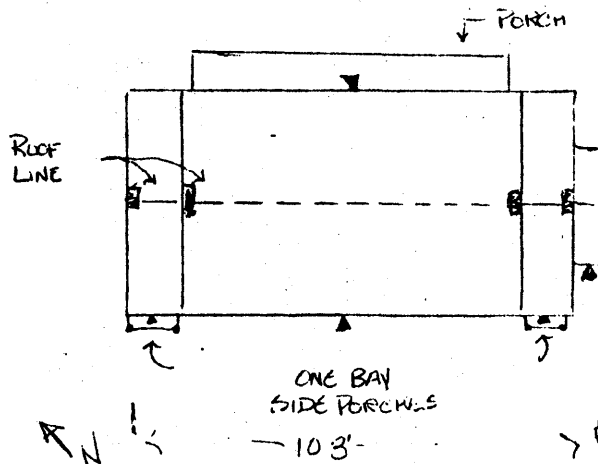

6. LOCALE/ENVIRONMENT (map)

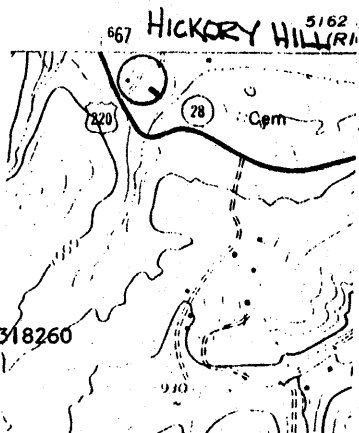

Petersburg East Quad  
UTM Ref: 17|667080|43|8260

8. (A.) ACREAGE (approx):

1 1/2 Acres

(B.) VERBAL BOUNDARY DESCRIPTION:

This farm complex is enclosed within a square approximately 1000' by 1000' to include all of the buildings. The square begins at a point on the east side of US Route 220, opposite the north corner of the barn.

Survey Region: \_\_\_\_\_  
Planning District: N/A

COUNTY: Hardy

PROPERTY NAME: HICKORY HILL

9. DESCRIPTION (clarify as appropriate):

<p>a. <u>Exterior Fabric</u></p> <p>stone _____</p> <p>brick <u>X Flemish bond facade</u></p> <p>concrete _____</p> <p>stucco _____</p> <p>weatherboard _____</p> <p>clapboard _____</p> <p>board &amp; batten _____</p> <p>shingle _____</p> <p>other _____</p>	<p>b. <u>Structural System</u></p> <p>masonry <u>X</u></p> <p>frame _____</p> <p>log _____</p> <p>metal _____</p> <p>other _____</p> <p>foundation <u>stone</u></p>	<p>c. <u>Roofing Material</u></p> <p>wood _____</p> <p>metal <u>standing seam</u></p> <p>slate _____</p> <p>tile _____</p> <p>asphalt _____</p> <p>composition _____</p> <p>other _____</p>
--	---	---

<p>d. <u>Associated Structures (use/type):</u></p> <p>outbuildings <u>log barn, smoke house</u></p> <p><u>sheds and other domestic and</u></p> <p><u>agricultural buildings.</u></p> <p>dependencies <u>attached dependencies</u></p> <p><u>at each side of main block</u></p> <p>other _____</p>	<p>e. <u>Integrity (include dates):</u></p> <p>original site/relocated <u>original</u></p> <p>alterations <u>minimal exterior</u></p> <p><u>alterations</u></p> <p>additions <u>Two front porches</u></p> <p><u>appear to date from ca. 1900.</u></p>
---	---

<p>f. <u>Condition:</u></p> <p>excellent <u>X</u></p> <p>good _____</p> <p>fair _____</p> <p>deteriorated _____</p> <p>abandoned _____</p>	<p>g. <u>Threats:</u></p> <p>None</p>
--	---------------------------------------

10. SIGNIFICANCE (use attachment sheet if necessary): This early 19th century farm complex is primarily significant for its architecture. The house is among the oldest of a group of large, substantial brick farmhouses dating from the 19th century in the South Branch Valley. The large log barn is not unique, but is a notable structure. The house has important features associated with the Federal style including the arched entrance way with its trim and the window heads.

<p>a. <u>Architect/Builder/Engineer:</u> <u>Solomon Cunningham</u> <u>(Original owner)</u></p> <p>b. <u>Style/Period:</u> <u>Federal</u></p> <p>c. <u>Date(s):</u> <u>Begun in 1809</u></p>
---

11. BIBLIOGRAPHY:

Adapted from survey documentation compiled by Nan Stevens, Region 8 Planning and Development Council, P.O. Box 887, Petersburg, WV 26847 in 1981, for the West Virginia Department of Culture and History.

Carpenter, Charles. West Virginia: People and Places. Richwood, W.Va.: Jim Comstock - West Virginia Heritage Encyclopedia, 1974, vol. 22, pp. 136-37.

12. FORM PREPARED BY Paula S. Reed DATE 8/09/84

a. <u>Address</u>	<u>207 S. Potomac Street, Hagerstown, MD 21740</u>
b. <u>Organization</u>	<u>Preservation Associates, Inc.</u>
c. <u>Phone no.</u>	<u>(301) 791-7880</u>

ATTACHMENT TO HISTORIC PROPERTIES INVENTORY FORM

HISTORIC PRESERVATION UNIT  
DEPARTMENT OF CULTURE & HISTORY  
THE CULTURAL CENTER  
CHARLESTON, WEST VIRGINIA 25305

1. Name(s) Historic/Common: Hickory Hill

4. Patricia Welton Garrat  
7201 Mockingbird Lane  
Scottsdale, Arizona 85253

Judith Welton Feinberg  
7201 Mockingbird Lane  
Scottsdale, Arizona. 85253

(#10. Significance, continued)

Built in 1809, the house of the Hickory Hill complex is perhaps the best example of Federal Style architecture in the South Branch Valley. Following a traditional five bay, central entrance plan, the house displays notable federal features including flemish bond brick work with original narrow mortar joints, pronounced flat arches above the windows and entrance trim featuring oval motifs, reeding and delicate dentiling. These features make the house outstanding not only within the South Branch Valley, but within the state itself where the Federal Style of architecture is not particularly well represented.

The outbuildings which contribute to the historic agricultural character of the complex are important for their contribution to the viability of the grouping. They are period structures and represent agricultural methods and practices of the 19th century. While West Virginia has a substantial number of log barns surviving, the one at Hickory Hill is particularly important because of its apparent age and its contribution to the prosperous farming complex illustrated by this grouping.

Historically, "Hickory Hill" is associated with the Cunningham and Welton names which are prominently tied to the earliest records of settlement of the South Branch Valley. The house was built by Solomon Cunningham, beginning in 1809, and passed into the hands of the Felix Welton family in 1873. The Cunningham name is mentioned among those of early South Branch Valley settlers who settled on lands belonging to Lord Fairfax. Welton's figure in local agricultural and political history.

HICKORY HILL, MOOREFIELD VICINITY, HARDY CO., W.VA.

1. "HICKORY HILL" - FEDERAL-STYLE BRICK FARM HOUSE, 1806  
(CONTRIBUTING)
2. LOG SMOKE HOUSE - TURN-OF-THE-CENTURY (19th CENT.)  
LOG SMOKEHOUSE (CONTRIBUTING)
3. LOG BARN - 19th-CENTURY BUILDING MADE OF  
NATIVE TIMBER (CONTRIBUTING)
4. OAK TREE - 400-YR.-OLD TREE CENTERED IN THE  
LAWN IN FRONT OF THE MAIN HOUSE FORMING  
NATURAL SETTING AND PROPERTY'S SCENIC ASSET

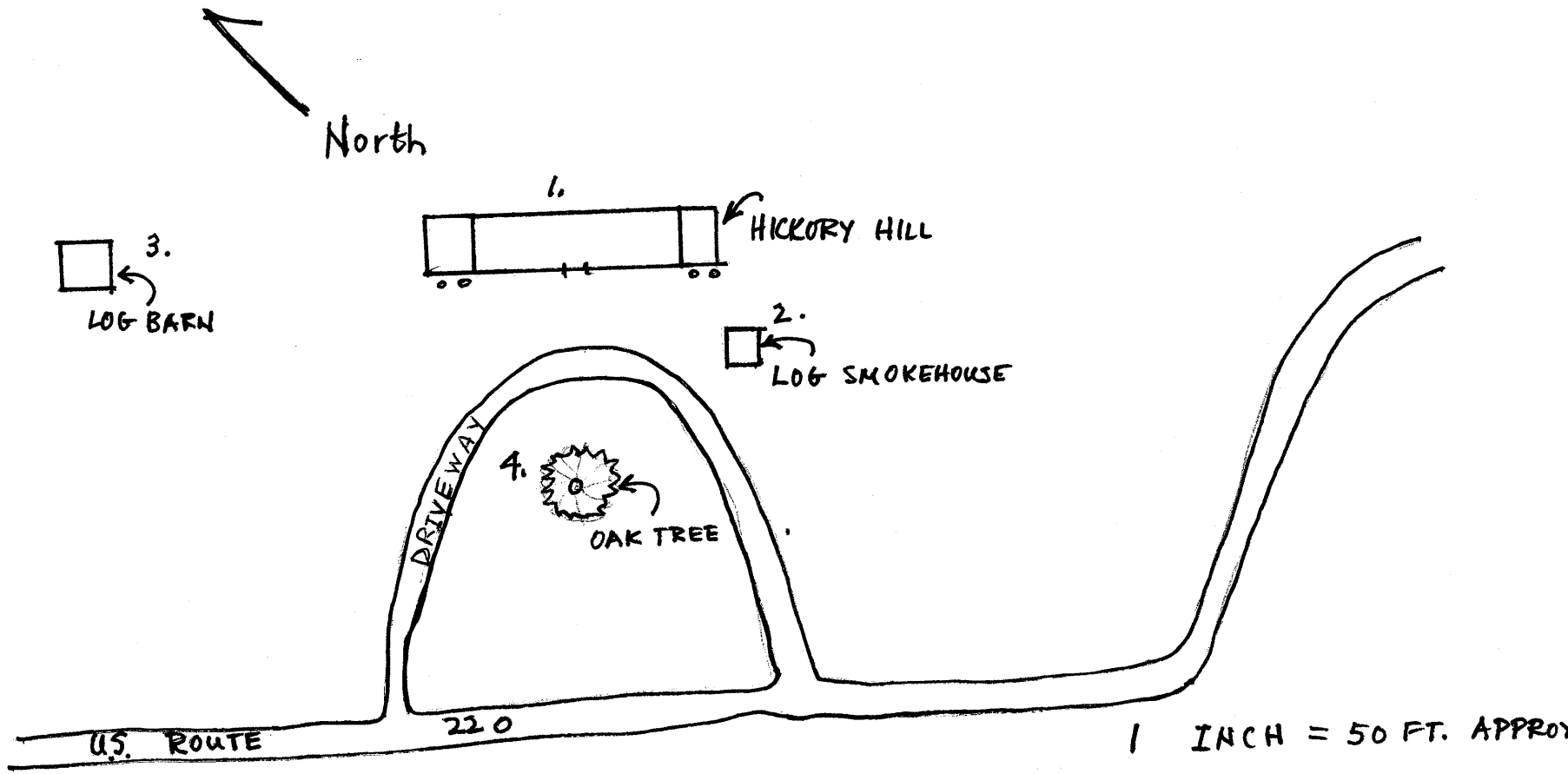

HICKORY HILL, MOOREFIELD VICINITY, HARDY CO., W.VA.