

United States Department of the Interior
National Park Service

RECEIVED

OCT 30 1992

National Register of Historic Places
Registration Form

NATIONAL
REGISTER

This form is for use in nominating or requesting determinations for individual properties and districts. See instructions in *How to Complete the National Register of Historic Places Registration Form* (National Register Bulletin 16A). Complete each item by marking "x" in the appropriate box or by entering the information requested. If an item does not apply to the property being documented, enter "N/A" for "not applicable." For functions, architectural classification, materials, and areas of significance, enter only categories and subcategories from the instructions. Place additional entries and narrative items on continuation sheets (NPS Form 10-900a). Use a typewriter, word processor, or computer, to complete all items.

1. Name of Property

historic name Balmoral Court

other names/site number The Balmoral 098-296-06039

2. Location

street & number 3055 North Meridian Street N/ not for publication

city or town Indianapolis N/ vicinity

state Indiana code IN county Marion code 097 zip code 46208

3. State/Federal Agency Certification

As the designated authority under the National Historic Preservation Act, as amended, I hereby certify that this nomination request for determination of eligibility meets the documentation standards for registering properties in the National Register of Historic Places and meets the procedural and professional requirements set forth in 36 CFR Part 60. In my opinion, the property meets does not meet the National Register criteria. I recommend that this property be considered significant nationally statewide locally. (See continuation sheet for additional comments.)

Patrick R. Roberts

10-20-92

Signature of certifying official/Title

Date

Indiana Department of Natural Resources

State of Federal agency and bureau

In my opinion, the property meets does not meet the National Register criteria. (See continuation sheet for additional comments.)

Signature of certifying official/Title

Date

State or Federal agency and bureau

4. National Park Service Certification

I hereby certify that the property is:

- entered in the National Register. See continuation sheet.
- determined eligible for the National Register See continuation sheet.
- determined not eligible for the National Register.
- removed from the National Register.
- other, (explain:)

Signature of the Keeper

~~Entered in the~~
National Register

Date of Action

Delores Byrum

11/27/92

Balmoral Court
Name of Property

Marion County, IN
County and State

5. Classification

Ownership of Property
(Check as many boxes as apply)

- private
- public-local
- public-State
- public-Federal

Category of Property
(Check only one box)

- building(s)
- district
- site
- structure
- object

Number of Resources within Property
(Do not include previously listed resources in the count.)

| Contributing | Noncontributing | |
|--------------|-----------------|------------|
| 3 | 0 | buildings |
| 0 | 0 | sites |
| 0 | 0 | structures |
| 0 | 0 | objects |
| 3 | 0 | Total |

Name of related multiple property listing
(Enter "N/A" if property is not part of a multiple property listing.)

NA

Number of contributing resources previously listed in the National Register

0

6. Function or Use

Historic Functions
(Enter categories from instructions)

DOMESTIC: Multiple Dwelling

Current Functions
(Enter categories from instructions)

DOMESTIC: Multiple Dwelling

7. Description

Architectural Classification
(Enter categories from instructions)

OTHER: Georgian Revival

Materials
(Enter categories from instructions)

foundation CONCRETE
walls BRICK
STONE: Limestone
roof ASPHALT
other WOOD

Narrative Description

(Describe the historic and current condition of the property on one or more continuation sheets.)

8. Statement of Significance

Applicable National Register Criteria

(Mark "x" in one or more boxes for the criteria qualifying the property for National Register listing.)

- Property is associated with events that have made a significant contribution to the broad patterns of our history.
Property is associated with the lives of persons significant in our past.
Property embodies the distinctive characteristics of a type, period, or method of construction or represents the work of a master, or possesses high artistic values, or represents a significant and distinguishable entity whose components lack individual distinction.
Property has yielded, or is likely to yield, information important in prehistory or history.

Criteria Considerations

(Mark "x" in all the boxes that apply.)

Property is:

- owned by a religious institution or used for religious purposes.
removed from its original location.
a birthplace or grave.
a cemetery.
a reconstructed building, object, or structure.
a commemorative property.
less than 50 years of age or achieved significance within the past 50 years.

Areas of Significance

(Enter categories from instructions)

ARCHITECTURE

Period of Significance

1916

Significant Dates

1916

Significant Person

(Complete if Criterion B is marked above)

NA

Cultural Affiliation

NA

Architect/Builder

MacLucas, William; George, Lawrence; and Fitton, Harry

Narrative Statement of Significance

(Explain the significance of the property on one or more continuation sheets.)

9. Major Bibliographical References

Bibliography

(Cite the books, articles, and other sources used in preparing this form on one or more continuation sheets.)

Previous documentation on file (NPS):

- preliminary determination of individual listing (36 CFR 67) has been requested
previously listed in the National Register
previously determined eligible by the National Register
designated a National Historic Landmark
recorded by Historic American Buildings Survey
recorded by Historic American Engineering Record

Primary location of additional data:

- State Historic Preservation Office
Other State agency
Federal agency
Local government
University
Other

Name of repository:

Indiana Historic Sites and Structures Inventory

Balmoral Court
Name of Property

Marion County, IN
County and State

10. Geographical Data

Acreage of Property 1.26

UTM References

(Place additional UTM references on a continuation sheet.)

1

| | | | | | | | | | | | | | | |
|------|---|---------|---|---|---|----------|---|---|---|---|---|---|---|---|
| 1 | 6 | 5 | 7 | 2 | 2 | 3 | 0 | 4 | 4 | 0 | 7 | 0 | 2 | 0 |
| Zone | | Easting | | | | Northing | | | | | | | | |

3

| | | | | | | | | | | | | | | |
|------|--|---------|--|--|--|----------|--|--|--|--|--|--|--|--|
| | | | | | | | | | | | | | | |
| Zone | | Easting | | | | Northing | | | | | | | | |

4

| | | | | | | | | | | | | | | |
|------|--|---------|--|--|--|----------|--|--|--|--|--|--|--|--|
| | | | | | | | | | | | | | | |
| Zone | | Easting | | | | Northing | | | | | | | | |

See continuation sheet

Verbal Boundary Description

(Describe the boundaries of the property on a continuation sheet.)

Boundary Justification

(Explain why the boundaries were selected on a continuation sheet.)

11. Form Prepared By

name/title Susan R. Slade

organization Slade Associates date May 5, 1992

street & number 4560 N. Broadway telephone 317/283-6114

city or town Indianapolis state IN zip code 46205

Additional Documentation

Submit the following items with the completed form:

Continuation Sheets

Maps

A **USGS map** (7.5 or 15 minute series) indicating the property's location.

A **Sketch map** for historic districts and properties having large acreage or numerous resources.

Photographs

Representative **black and white photographs** of the property.

Additional items

(Check with the SHPO or FPO for any additional items)

Property Owner

(Complete this item at the request of SHPO or FPO.)

name Buckingham Balmoral Historic Partners

street & number 5401 N. Pennsylvania telephone _____

city or town Indianapolis state IN zip code 46220

Paperwork Reduction Act Statement: This information is being collected for applications to the National Register of Historic Places to nominate properties for listing or determine eligibility for listing, to list properties, and to amend existing listings. Response to this request is required to obtain a benefit in accordance with the National Historic Preservation Act, as amended (16 U.S.C. 470 *et seq.*).

Estimated Burden Statement: Public reporting burden for this form is estimated to average 18.1 hours per response including time for reviewing instructions, gathering and maintaining data, and completing and reviewing the form. Direct comments regarding this burden estimate or any aspect of this form to the Chief, Administrative Services Division, National Park Service, P.O. Box 37127, Washington, DC 20013-7127; and the Office of Management and Budget, Paperwork Reductions Projects (1024-0018), Washington, DC 20503.

United States Department of the Interior
National Park ServiceNational Register of Historic Places
Continuation SheetSection number 7 Page 1 Balmoral Court

The Balmoral Court was originally nineteen, two and one half story townhouses grouped in three structures (Photos 1, 2). Symmetrically arranged around a rectangular courtyard, the Georgian Revival buildings of red brick with limestone trim are robustly and completely detailed with a variety of Georgian Revival elements which are concentrated around the entrances which face the large, open courtyard.

The identical north and south ranges are terminated at the west ends by large, two and one half story, three bay units which feature center entrances. The whole composition appears as a single family house (Photos 3, 4, 5). The slightly raised, three-step concrete stoops provide access to the entrances. A header course of bricks extends from the stoop level as a continuous drip molding. Each entrance door features a beveled glass panel set above three small vertical wood panels. Leaded sidelights set above recessed panel bases are topped with a leaded oval fanlight. A projecting open arched pediment with keystone set on carved console brackets attached to the flanking flat entrance pilasters completes the center entrance composition. Paired double-hung, six over six light sashes flank the entrance. A soldier course brick lintel with drop ears and header course sill finish each opening. In the second story, three single, multi-paned, double-hung windows centered above the first story bays are set immediately beneath the deep, heavily molded fascia with dentils and finished with header sills. The corners of these prominent west end units are finished with raised limestone quoins which extend from the drip molding to the fascia. The north-south gable roofs of these two end units are pierced with three gable dormers each. Round arched windows are framed with wood paneled pilasters and keystone. Originally the top sash of these double hung windows was fitted with a round arched unit which featured vertical muntins in a pointed arch pattern. The round arch has been infilled with plywood and insulation. New one over one light sashes with insulated glass were installed by a previous owner.

The symmetrically arranged courtyard elevations of the north and south ranges are similarly detailed (Photos 6, 7, 8). Seven entrances per range provide access to the six original units. The far west entrances with small scrolled, bracketed pediments provide a second entrance to the large west end units. These doorways have no sidelights. The two bay width of this open gable end is completed with a single six over six light sash to the east of the entrance. In the second story, similar single sashes maintain the two bay pattern. The open gable itself is filled with a brick framed arched window with limestone keystone.

United States Department of the Interior
National Park ServiceNational Register of Historic Places
Continuation SheetSection number 7. Page 2

Balmoral Court

As the courtyard elevation continues east, the other six entrances are alternately detailed with projecting balustraded porticos, simple, dentiled entablatures and a centered pedimented portico (Photos 9, 10). All upper entrance accents are supported by Tuscan wood columns, engaged or accompanied by paneled wall pilasters. Each entrance door composition approached by the three step stoop is finished as those in the west end units. However, only the centered, open arched pediment is fitted with the oval fanlight. While all entrance doors feature a single top panel over three vertical wood panels, some doors have beveled plate glass for the top panel. Others have solid wood panels. Above the continuous drip molding, each entrance is flanked by three-window units. The center opening is set with a six over six light sash. It is flanked by four over four light sashes. The grouping is framed as those in the west end. Multi-paned, double-hung sashes of the second story windows occur in a paired or single arrangement. All are set adjacent to the heavily molded and dentiled fascia. At the east end of each range, this pattern is broken by the open gable ends of the far east units. The return of the fascia tops the corner quoin motif which frames the east end of the courtyard elevation. This treatment balances that of the courtyard elevations of the west end units. The fascia with built-in gutters finishes the pitched roof set between the two open gables. Within this roof line and centered above each accented entrance, is a pedimented dormer. Paired, single light sashes are set within a molded arched frame. Each frame is finished with a keystone.

The rear elevations of the north and south ranges feature two-story, flat roofed projecting bays, one per unit, effectively creating a lightwell and a method of egress (Photos 11, 12)). Within each bay, iron grill flooring panels set with iron railings and stairs are installed to provide access from the rear basement level to the kitchens which are located in this bay. The floor panel of the first floor serves as a shelter for the basement entrance doors which feature multi-panel lights above a paneled base. All kitchen doors follow this same pattern. The bays are set with paired multi-paned, double-hung windows. In contrast to the consistent elaborate Georgian Revival detailing of the courtyard facades, the rear and east elevations of these two ranges are treated in a very utilitarian manner with no decorative trim.

The west courtyard elevation of the east building features a pedimented portico with flanking balustrades, all supported by six colossal wood columns with Roman Corinthian capitals (Photos 13, 14, 15). The slightly projecting temple front is finished to the north and south by the prominent quoins. The immediately adjacent north and south entrances are topped with slightly projecting, open arched pediments which are detailed with keystone, fanlight and are supported by engaged Tuscan columns. The entrances located beneath the balustraded pediment extensions have no lintel trim. Narrow sidelights flank the door. The prominent center entrance set beneath the pediment itself is capped with a projecting balustraded canopy supported by console brackets.

United States Department of the Interior
National Park ServiceNational Register of Historic Places
Continuation SheetSection number 7. Page 3

Balmoral Court

Window groupings and frames on this range repeat the fenestration pattern established on the courtyard elevations of the north and south ranges. Second story windows are set with brick lintels. The entire wall composition is finished with a bold, dentiled, heavily molded fascia which features a prominent cornice set with modillions. These same details are contained within the prominent pediment. The hipped roof is pierced with a series of dormers which are located to correspond to the five entrances below. North and south dormers are detailed as those in the north and south ranges. Dormers with a single sash are set behind the balustraded north and south extensions of the pediment. A pair of small pedimented dormers set with single arched hopper sashes flank the valleys of the projecting pediment.

To the north, the east building has an attached brick, two-story, gable roofed carriage house which is set to the alley grade and totally hidden from the main east view of the large courtyard (Photo 16). The treatment is utilitarian. Single, double-hung windows are framed by soldier lintels and header sills. A simple fascia finishes the upper wall and returns to accent the open gable ends. The first story of the east elevation is fitted with four, single wood paneled overhead garage doors. The west elevation at this level has a small workshop area accessed by a multi-paned and paneled door. The north elevation, northwest corner, contains a similar door which provides entrance to the straight-run staircase accessing the original custodian's unit on the second floor. To the south, the east building has an attached brick, one-story, flat roofed mechanical room, formerly the boiler room. This section of the building also is set to the alley grade and is not visible from the main east view of the courtyard. On the alley elevation, a single fire door and a garage door provide access to this purely utilitarian space. Original window has been boarded.

One of the most unique architectural features of the complex is the cantilevered balcony which extends along the east or alley elevation of the east building (Photo 17). This walkway and terrace projects out over the eight garages below. It also provides access to the three exterior metal staircases which service this building. Combined with the very rectilinear projecting bays, one per unit, this horizontal accent gives this elevation a feeling of massing that is similar to that found in early twentieth century Dutch multi-unit architecture.

Originally the two west end units contained living room, dining room, kitchen with eating area on the first floor, three bedrooms and full bath on the second floor and two bedrooms and bath with tub on the third (Photos 18, 19, 20). All units were finished with painted woodwork: six inch molded baseboard, flat six inch trim finished on the perimeter with a slightly raised, mitered bead. All original interior doors have two vertical panels or two horizontal panels. In the upper levels it is common to find five panel doors. Replacement doors are

United States Department of the Interior
National Park ServiceNational Register of Historic Places
Continuation SheetSection number 7. Page 4

Balmoral Court

painted flush core doors. The staircase with square newel and corner posts has flat plain balusters. The other seventeen apartments had a similar number of individual rooms, but they were somewhat smaller in total square footage (See Plans). The complex was altered in 1955. Each single interior entrance foyer was enclosed and fitted with apartment entry doors, one which opens to the original staircase to provide access to the apartment unit comprised of the original second and third floors (Photos 21, 22, 23, 24, 25). The entranceway into the original living room was infilled to provide access to a one-bedroom, first floor apartment with basement storage and laundry area. At this time built-in bookcases were included in the living rooms of the larger units. The bedrooms in the first floor, one-bedroom units were fitted with built-in drawer storage chests (Photos 26, 27, 28, 29 30).

Balmoral Court is sited parallel to North Meridian Street, today a busy, four-lane thoroughfare. Although the building line and set-back were established in the property deed, the site has been modified through the years. Originally a semi-circular drive from North Meridian Street provided access to the courtyard entrances. This drive and its set-back have been incorporated into a two-car deep parking lot which separates the west entrances and north-south sidewalk from the public sidewalk. The courtyard remains as originally defined along the west side by the low brick walls with cast balusters and railings. These walls extend from the west ends of the buildings to the east/west sidewalk entrances and continue to frame a centered stepped entrance into the courtyard. Low piers with limestone caps flank these entrances. Originally the centered piers were fitted with colossal limestone urns similar in shape to large Greek kylixes. The piers flanking the sidewalks were topped with lanterns. Courtyard lighting was continued at the east end of this open space by the installation of two large globe-topped lamp posts flanking the east building. Today, lighting is maintained in these locations as well as on the piers which flank the concrete stairways located to the north and south of the north and south ranges. These stairways provide access to the east/west sidewalks which connect to the concrete pads of the original exterior basement entrances. The entire basement or lower level of the Balmoral Court is exposed at grade level immediately to the east of the west elevations of the north and south ranges. The east property line is marked by the adjacent north/south alley.

The current owners have completed a conditionally approved substantial rehabilitation. The general scope of work included removal of extensive ivy and pressure wash of exterior brick and limestone. Selective tuckpointing was completed. Cantilevered rear balcony above garage doors was reinforced with a steel beam and brickwork rebuilt using salvaged and matching new material. All deteriorated wood portico/pediment details including columns, capitals,

United States Department of the Interior
National Park ServiceNational Register of Historic Places
Continuation SheetSection number 7. Page 5

Balmoral Court

balustrade balusters and railings were repaired and/or replaced with like materials. Existing windows and storm/screen units were repaired and repainted. All existing metal fire escapes were wire brushed and repainted. New metal railings and open grill security doors were installed on the rear balcony. New slate gray asphalt roofing was installed over existing asphalt roofing on the three main buildings. Low air conditioning condenser units were installed on the rear slopes of these roofs. Deteriorated slate carriage house roof was replaced with the new slate gray asphalt shingles. Aluminum dormer siding was replaced with the asphalt shingles to simulate the original installation of gray slate. All flat roofs of the mechanical room and porticos received new rolled roofing. The boiler chimney was removed.

On the interior, the original configuration of the two large west end units was restored. The remainder of the 1955 reconfiguration of units was maintained. Fourteen additional studio units were installed in the basement spaces of the north and south ranges (Photos 31, 32, 33). The original caretaker's unit above the attached carriage house was repaired where required. All entrance vestibules, including leaded sidelights and toplights, paneled and glazed exterior doors and interior raised panel unit entry doors repaired as required and repainted. All vestibules received new sheet goods flooring. In the thirty-six units which resulted from the 1955 reconfiguration, all historic and existing fabric was repaired and repainted. All hardwood floors were refinished. In the twelve one-bedroom flats, six each in the north and south ranges, the interior basement stairways were removed, providing additional storage for this unit and allowing the basements to be converted to studio units with existing exterior entrances. In the east building, the basements were finished as a den or studio (Photo 34). All kitchens and baths were retained in existing locations. New appliances, countertops and work area cabinets were installed. New vinyl flooring was installed. In baths, existing tile was repaired, existing fixtures repaired, reglazed or replaced. In the fourteen new basement studio units, existing multi-light and paneled entrance doors and multi-light, double-hung windows and accompanying trim were repaired as required. New baths, kitchens and closets were created within the load-bearing walls. New finishes in these units do not replicate those in the remainder of the complex. All units received individual HVAC systems. The furnace has been located in a centrally located closet. Ductwork was installed within the dropped ceiling of the rear hall and bathroom in the first floor units. Similar installation was done in the two-story units. As rehabilitated, Balmoral Court contains fifty-one units.

United States Department of the Interior
National Park ServiceNational Register of Historic Places
Continuation SheetSection number 8 Page 1 Balmoral Court

In Indianapolis, the Balmoral Court represented large living spaces in rental units when it was completed in 1916. At this time, there were no other similar apartment complexes which offered over 1900 square feet of multi-storied living space plus a full basement. The rowhouse concept was unique in this city (1). The complete and robust styling of the Georgian Revival complex designed by a newly emerging, full-service architectural firm created an exterior ambiance which could not be found in any other building located on N. Meridian Street or in the neighboring east residential area between Fall Creek and 38th Street, a developing upper class neighborhood, 1910 - 1920. As an outstanding and early example of the Georgian Revival style applied to ranges of townhouse units which offered luxurious living accommodations to the city's elite, the Balmoral Court meets National Register Criterion C in the area of architecture.

Other apartment rental complexes constructed prior to 1915, offered similar living spaces arranged as an Eastern flat. These buildings are located primarily in Indianapolis' original mile square area or within the Old Northside Historic District (2). The Balmoral Court, upon completion, offered a tenant and service attendants large and commodious living spaces on a street which had been established as the premier address street in the city as early as 1890. The residences which lined the street from North Street (1000 N.) to Fall Creek (2700 N.) were large eclectic revival single family dwellings which served as household units for Indianapolis' wealthy families. By 1914, this development, as it moved north of Fall Creek along Meridian Street, included four apartment buildings. The Buckingham, a three-story, thirty unit, U-shaped courtyard complex was arranged as an Eastern flat building: five entrances with six large, three bedroom units per entrance (3). The Hudson Arms was a three-story Eastern flat building located at 2715 N. Meridian Street. Two other apartment buildings were constructed by this time just north of 30th Street, on N. Pennsylvania Street, the Esplanade and the Esplanade Annex (4). The Esplanade, an Arts and Crafts multi-entranced apartment building, included a combination of apartment sizes in one, two or three-story arrangements in which the third story was a low, opened ceiling single room. Of this group of apartment buildings, Balmoral Court is the only townhouse complex. It is the second courtyard complex constructed, following the standard set by its neighbor to the north, The Buckingham in 1910. Two other townhouse courtyard complexes have been identified: the Studio Court Apartments (c. 1917), 1922 N. Talbott Street,

United States Department of the Interior
National Park ServiceNational Register of Historic Places
Continuation SheetSection number 8. Page 2

Balmoral Court

Herron-Morton Place Historic District and Penwood at 3540 North Pennsylvania Street (c. 1920). The Penwood is detailed with buff brick set with flush limestone quoins, projecting piered porches, and green glazed tiled roof. This is a very modest statement of the Colonial Revival style.

The Balmoral Court with the variety of robust, finely detailed Georgian Revival elements creates individualized entry openings to each three-story or house-like unit. From the columned porches, fully glazed entrance doors with leaded sidelights, symmetrically arranged windows and roof dormers, the design concept of the Balmoral Court was to present on the exterior, a unique statement about each three-story or house-like unit. The selection of this specific style was an attempt to present rental property which had a single-family, residential character to a discerning public. Prior to 1916, in Indianapolis, multi-unit residential buildings were frequently detailed with historically referenced architectural elements concentrated around the main entrance. The most highly stylized, complete decorative treatments occur on buildings which present Collegiate Gothic or Jacobethan facades such as the Maryden, 1308 N. Central Avenue, Old Northside Historic District (1916) or the Buckingham, 3101-3119 N. Meridian Street (1910). The Balmoral Court is the first of many fully and elaborately detailed apartment buildings or complexes of this period in the Georgian Revival style completed in Indianapolis (5). At the west ends of the north and south ranges, the units feature the slightly raised, centered, pedimented entrances set with sidelights and oval fanlight and flanked by multi-paned, symmetrically arranged windows topped with drop eared lintels in first story. In the second story, the multi-paned windows are set against the deep, heavily molded and dentiled fascia. The entire brick wall composition is finished with prominent quoins. Three symmetrically arranged pedimented dormers are set with arch topped windows finished with keystone and flanked with columns. From the slightly elevated base with accompanying drip course to the gable roof with dormers, these compositions are complete in their interpretation of the American Georgian style, c. 1770. The courtyard elevations of the north and south ranges further amplify the completeness of the Georgian Revival style. The elaborateness of detail and increased scale of the slightly projecting temple front of the east building replete with colossal columns and prominent pediment finished with centered carved wreath, dentils and modillions bring to a dynamic conclusion the completeness of the stylistic statement of Balmoral Court.

Multi-unit buildings in Indianapolis during the second decade of the twentieth century often were built by known and well-connected real estate developers, financiers and well-known architects (6). With the development and construction of the Balmoral Court, an architectural firm comprised of architect/designer and real estate packager George and architect/contractor Fitton, MacLucas, George and Fitton of Indianapolis, combined forces with the landowner Clarence Stanley and vice president of the Indianapolis Lumber Company Harry M. Moore to form the Balmoral Court Company. Between 1909 and 1913, individual members of the firm, particularly Lawrence George and Harry Fitton, had been active

United States Department of the Interior
National Park ServiceNational Register of Historic Places
Continuation SheetSection number 8. Page 3

Balmoral Court

designers of single-family residences within the Meridian Park Historic District (NR 2-23-90). This district is located immediately east of the Balmoral Court. During the period of construction of the complex, Lawrence George lived at 3121 N. Pennsylvania Street, a Craftsman/Tudor Revival house. At 3133 N. Pennsylvania, George designed a fully clapboarded, open gabled Craftsman house in c. 1910. Harry Fitton lived at 3105 N. Pennsylvania Street. This residence is a fine, robust example of the smaller Colonial Revival residences which became very popular in subdivisions constructed after World War I. This c. 1913 center entrance house is finished with an off-set second story set with modillions. The main cornice and projecting pedimented entrance set on Tuscan columns are finished with large separated dentils. Fitton had designed and constructed a series of residences on N. Delaware Street with permits issued to Builder's Realty, a company which he had founded along with Builder's Construction Company (7). Thus members of the firm were most familiar with this developing northside neighborhood and the styles of residential architecture which would appeal to members of the fast growing Indianapolis upper middle class.

With the successful Buckingham, a Jacobethan Revival courtyard apartment building well-established on N. Meridian Street by May of 1915, it was not surprising to see a similar project undertaken immediately south. Although the east building was not completed by the time the survey was done for the City Directory of 1916, both north and south ranges had prominent citizens both from established Indianapolis families and executives of new business ventures coming to the city. Thomas Kaufman, loan broker with his father-in-law John Aufderheide, and his wife May Aufderheide became one of the first residents at the Balmoral Court. Between 1908 and 1913, May Aufderheide was one of the leading Indiana jazz composers. Her hits included "Dusty Rag" (1908) and "Thriller Rag" (1909). Henry Titsworth, president of The Clay Products Company, Brazil, Indiana, resided in the large northwest unit. He had come to Indianapolis to establish a sales office. The new office sales manager, Fred A. Rogers, also moved from Brazil to the Balmoral Court. Through the 1920's, the residents at Balmoral Court reflected the growing businesses in the city, Thomas J. Owens, president, Century Life Insurance; Albert Lieber, president and general manager, Indianapolis Brewing Company; Douglas F. Wheeler, president, Wheeler-Schebler Carburetor Company; Lawrence George, architect of the complex. Beginning in the mid-1930's, residents of Balmoral Court reflected the relocation of Butler University from Irvington, on the east side of the city, to 4600 Sunset Boulevard, seven blocks west of N. Meridian Street. Professors and administrators found the Balmoral Court to be a convenient and hospitable place to live.

Balmoral Court is an outstanding example of a townhouse-courtyard complex designed in a fully developed Georgian Revival style. It is the earliest example of this style in apartment design in the northward development of Indianapolis' premier residential neighborhoods, 1910 - 1920.

United States Department of the Interior
National Park Service

National Register of Historic Places Continuation Sheet

Section number 8. Page 4

Balmoral Court

Endnotes

(1) Pearson Terrace (1902), 928-940 North Alabama Street, Indianapolis, (NR 3-1-84), appears to be the earliest extant townhouse group in the city.

(2) See Apartments and Flats of Downtown Indianapolis Thematic Resources Nomination (9-15-83) and Old Northside Historic District Amendment (9-27-84).

(3) The Buckingham, an apartment building designed by the well-known Indianapolis firm of Rubush and Hunter in 1909-10, is located immediately north of the Balmoral Court. The same owner has completed a nomination for listing in the National Register of Historic Places.

(4) The Hudson Arms was demolished prior to the undertaking of rehabilitation of the Marott Hotel (NR 6-25-82). This large Eastern flat which featured prominent paired projecting three-story porches similar to those at the Coulter Flats (NR 5-31-90). The Esplanade (NR 6-16-83) and the Esplanade Annex, Meridian Park Historic District (2-23-90), were completed by 1913.

(5) Between 1916 and 1927, a variety of Colonial Revival apartment buildings were built throughout Indianapolis. Within the boundaries of significance for Balmoral Court, 2700 - 3800 N. Meridian Street and the simultaneous residential development on east adjacent streets including N. Pennsylvania Street and Washington Boulevard, none is as large a complex nor as completely detailed in the Georgian Revival Style nor as early in date. In the Center Township, Marion County Inventory, in this area, the Charmwood Apartments at 3419-35 N. Pennsylvania is listed as an outstanding building in the Colonial Revival Style. The flush keystones set above the windows, linear wrought iron balconies framing French doors and crispness of component massing clearly indicates the Federal Revival Style. It was constructed after 1916.

(6) Edgar Spink, one of the largest developers and builders of apartment buildings in Indianapolis during this period, retained as part of his staff, architects, project managers and/or engineers who were rarely designated by name as project architect/designer. David Coulter was owner, developer and resident at the Coulter Flats. Edgar Hunter designed, contracted and lived with other members of his family at the Blenheim (1907), 1827 N. Talbott Street, Herron-Morton Place Historic District. In 1910, Rubush and Hunter designed, contracted, owned and lived in the Buckingham. See note above.

(7) During the construction of Balmoral Court, Lawrence George is listed as president of Builder's Real Estate Company and Fitton is listed as vice-president and secretary. In 1920, Fitton is the president of Builders Construction Company which specialized in design and construction of industrial

United States Department of the Interior
National Park ServiceNational Register of Historic Places
Continuation SheetSection number 8. Page 5

Balmoral Court

and commercial buildings and apartment houses. The secretary-treasurer of the company at this time was Owen M. Mothershead, who had replaced Fitton as a member of the board of directors, Balmoral Court Company, and also served as a board member of the St. James Court Company (NR 2-12-87). From records for specific buildings, it is evident that Fitton no longer participated in design and construction with George and MacLucas by 1921. Although George and Fitton were partners in the Delaware Realty Company, owners and builders of Delaware Court, 1917, (NR 9-15-83), George and MacLucas are the architects of record for the Seville, 1921, (NR 6-22-87). George and MacLucas are also architects of record for MacLucas' own house, 2837 Washington Boulevard, 1924, and large and imposing Colonial Revival residences at 4122 N. Meridian Street, North Meridian Street Historic District (NR 9-22-86) and 4111 and 4115 Washington Boulevard. The last three residences were completed for the officers of the Meyer-Kiser Bank, the primary source of funding for the Balmoral Court project. Lawrence George maintained an office at the Meyer-Kiser Bank until the bank failed and closed its doors in 1935. MacLucas died in 1926. Fitton died in 1931. By 1937, Lawrence George is no longer listed as a resident of Indianapolis.

United States Department of the Interior
National Park Service

National Register of Historic Places
Continuation Sheet

Section number 9,10 Page 1 Balmoral Court

9. Bibliographical References

Baist, G. William (compiler). Real Estate Atlas of Surveys of Indianapolis and Vicinity, Indiana; compiled and published from Official Records, Private Plans and Actual Surveys. Philadelphia: G. William Baist, 1908, 1916, 1927.

Balmoral Court Company, Articles of Incorporation. Indiana State Library.

Chain of Title, Marion County Clerk's Office.

"E. E. Crane Residence, Indianapolis." Country Life, May, 1927, p.97.

Indiana Construction Recorder. Vol. 2, May 1, 1920; October 23, 1920; November 6, 1920.

Indianapolis City Directory. Indianapolis: R. L. Polk & Company, 1914 - 1984.

Indianapolis Star. April 10, 1921.

Rollins, Suzanne T. "Meridian Park Historic District." National Register of Historic Places nomination. Indianapolis. February 23, 1990.

Sanborn Fire Insurance Maps. New York: Sanborn Map and Publishing Co., 1915, 1941.

Verbal Boundary Description

Lots 6 and 7, Osgood's Meridian Park Addition, City of Indianapolis. The dimensions of the nominated property are 200' in width (N/S) and approximately 280' in depth. Note: The alley angles slightly southwest at the property's midpoint.

Boundary Justification

The boundary includes two complete city lots. The buildings are centered on the property within seven feet of the north and south lot lines.

United States Department of the Interior
National Park Service

National Register of Historic Places
Continuation Sheet

Section number _____ photographs
Page 1

Balmoral Court

PHOTOGRAPH INFORMATION

#1 Balmoral Court, Indianapolis, Indiana
Camera pointing east, west elevation.
Bass Photograph, c. 1917, neg. no. 67767
Indiana Historical Society

The following information is identical for all photographs except as noted:

Balmoral Court
Indianapolis, Indiana
Susan R. Slade
June 19, 1989
Slade Associates, 4560 N. Broadway, Indianapolis, In., 46205

#2 Camera pointing east, aerial view of complex, July 25, 1986.

#3 Camera pointing southeast, west elevations and part of north elevations of north and south ranges.

#4 Camera pointing south southeast, north and west elevations of north range.

#5 Camera pointing south southeast, north and west elevations of south range.

#6 Camera pointing southeast, north elevation of south range.

#7 Camera pointing east northeast, south elevation of north range at left, west elevation of east building at center.

#8 Camera pointing southeast, southeast corner of courtyard, north elevation of south range at right.

#9 Camera pointing east, south elevation of north range, detail of balustraded entrance, detail of console bracket of side entrance, west end unit.

#10 Camera pointing west, south elevation of north range, detail of balustraded entrance.

#11 Camera pointing east southeast, north elevation of north range.

United States Department of the Interior
National Park Service

National Register of Historic Places
Continuation Sheet

Section number _____ photographs _____ Page 2

Balmoral Court

- #12 Camera pointing east, south elevation of south range.
- #13 Camera pointing east, west elevation of east building.
- #14 Camera pointing east, aerial view of west elevation of east building.
- #15 Camera pointing south, west elevation of east building, detail of projecting temple front.
- #16 Camera pointing northeast, west elevation of carriage house of east building.
- #17 Camera pointing north northwest, east elevation of east building.
- #18 Camera pointing west, Unit D, entrance hall and front door.
- #19 Camera pointing northeast, Unit D, entrance hall and stairs, living room at right.
- #20 Camera pointing northwest, Unit D, dining room.
- #21 Camera pointing east, typical north and south range vestibule, specifically Unit 3A/B.
- #22 Camera pointing northeast, typical entrance hall and stairwell, specifically Unit 3B.
- #23 Camera pointing southeast, typical upper level townhouse living room looking into entrance hall, specifically Unit 3B.
- #24 Camera pointed southwest, typical upper level townhouse kitchen eating area with exterior rear door at right, specifically Unit 3B.
- #25 Camera pointing north, typical upper level townhouse dormered bedroom, specifically Unit 11 B.
- #26 Camera pointing southeast, typical 1st floor one-bedroom unit, living room, specifically Unit 15A.
- #27 Camera pointing northeast, typical 1st floor one-bedroom unit, bedroom, specifically Unit 15A.
- #28 Camera pointing southwest, typical 1st floor one-bedroom unit, bedroom,

United States Department of the Interior
National Park Service

**National Register of Historic Places
Continuation Sheet**

Section number _____ photographs _____ Page 3

specifically Unit 15A.

#29 Camera pointing north, typical 1st floor one-bedroom unit, living room, specifically Unit 5A.

#30 Camera pointing north, typical 1st floor one-bedroom unit, corridor, specifically Unit 5A.

#31 Camera pointing east, typical lower level studio unit, entrance, specifically Unit 11L.

#32 Camera pointing north, typical lower level studio unit, living room, looking to entrance door and window, specifically Unit 14L (Leasing Office).

#33 Camera pointing southwest, typical lower level studio unit, living/dining area, specifically Unit 14L (Leasing Office).

#34 Camera pointing southeast, typical 1st floor one-bedroom unit, east building, lower level den with garage door at left, specifically Unit 10A.

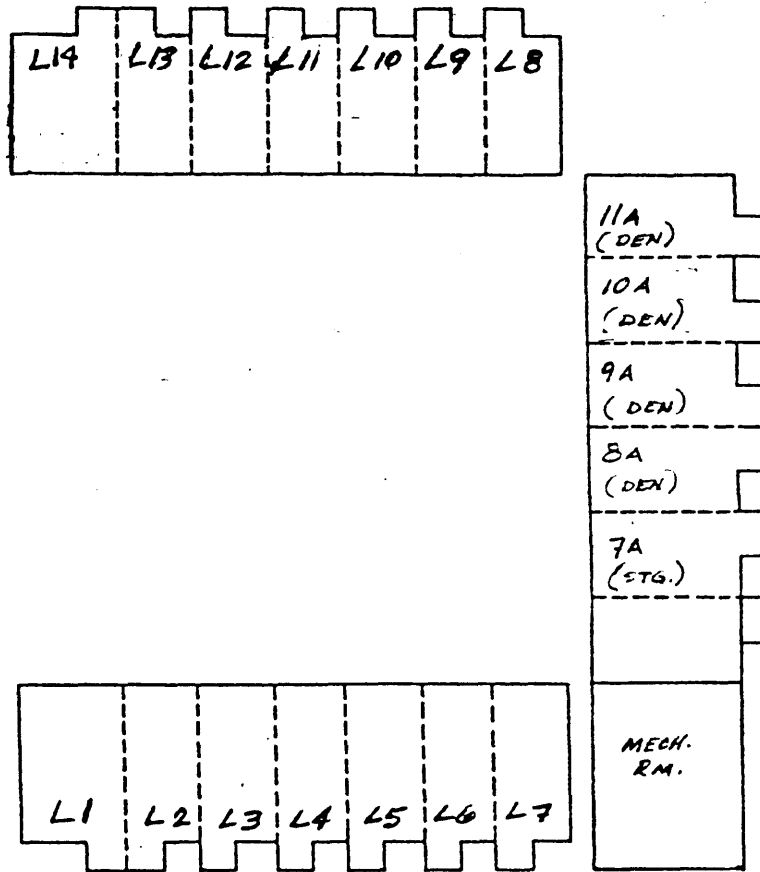

BALMORAL APARTMENTS KEY PLAN
 3055 N. MERIDIAN ST.

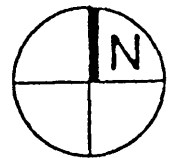

STUDIO LEVEL - 1st Floor 13 Units
 (BASEMENT LEVEL)

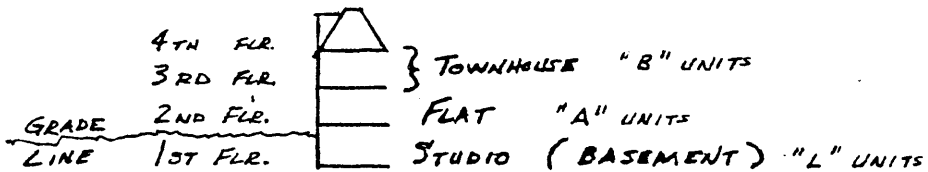

BALMORAL

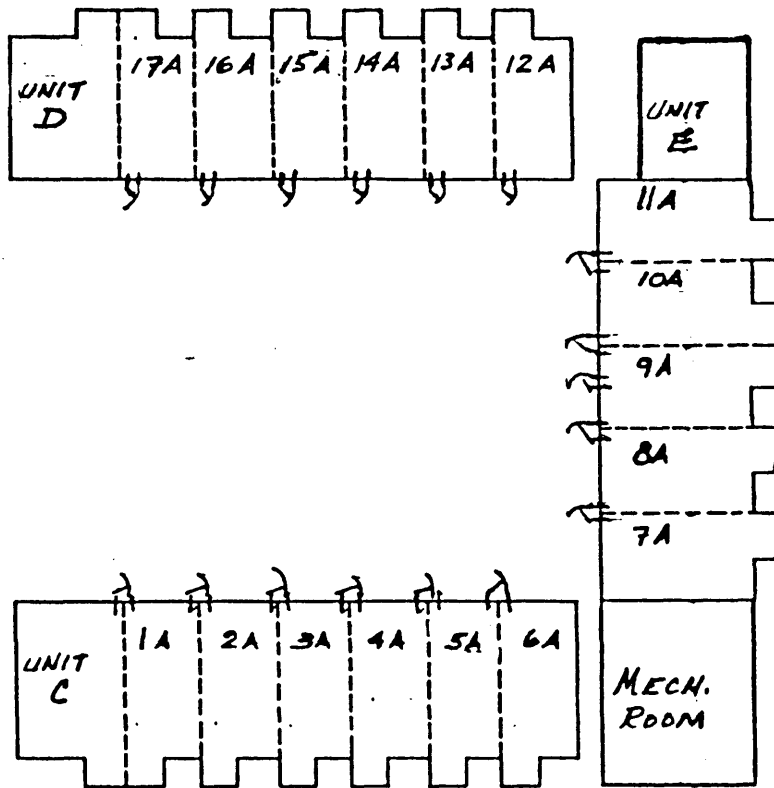

BALMORAL APARTMENTS KEY PLAN
 3055 N. MERIDIAN ST.

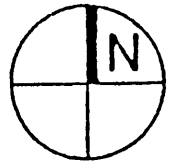

FLAT LEVEL 18 Units
 (2ND FLOOR)

- 4 Units, Flat plus Den below. 8A, 9A, 10A, 11A 1134 s.f.
- 12 Units, Flat 1A, 2A, 3A, 4A, 5A, 6A, 12A, 13A, 14A, 15A, 16A, 17A 704 s.f.
- 1 Unit, Flat plus Lower Level Storage. 7A 1134 s.f.
- 1 Unit, Flat above Carriage House. w/ LOWER LEVEL STG. 1211 s.f. UNIT E

18 Units Total

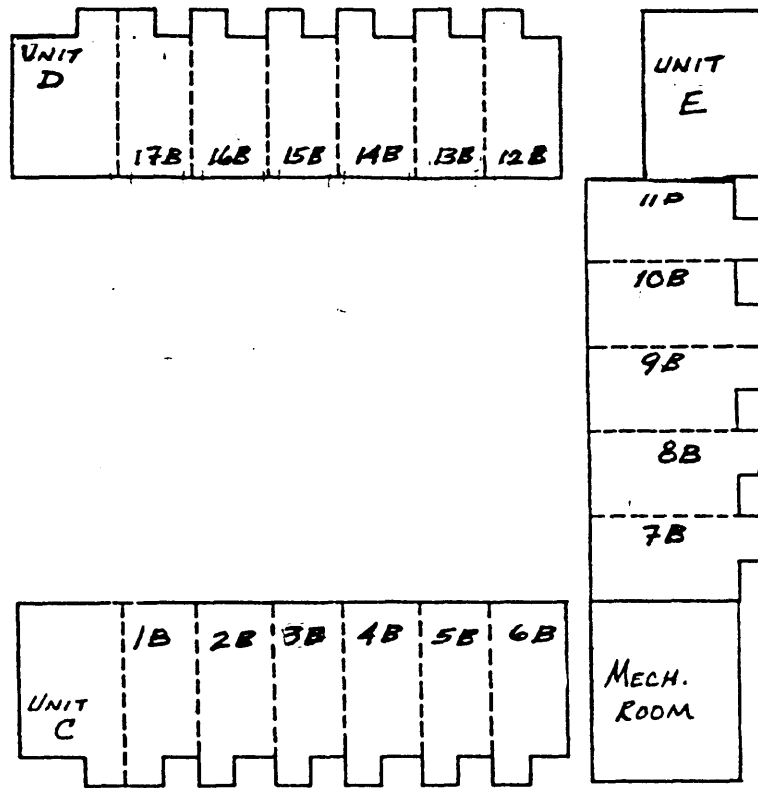

BALMORAL APARTMENTS KEY PLAN
 3055 N. MERIDIAN ST.

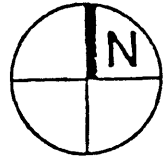

TOWNHOUSE LEVEL 19 Units
 (3RD & 4TH FLOORS)

- 2 Units, 3 Floor Townhouse..UNIT..C..&..D.....1973 s.f.
- 17 Units, 2 Floor Townhouse.....1280 s.f.

19 Units Total

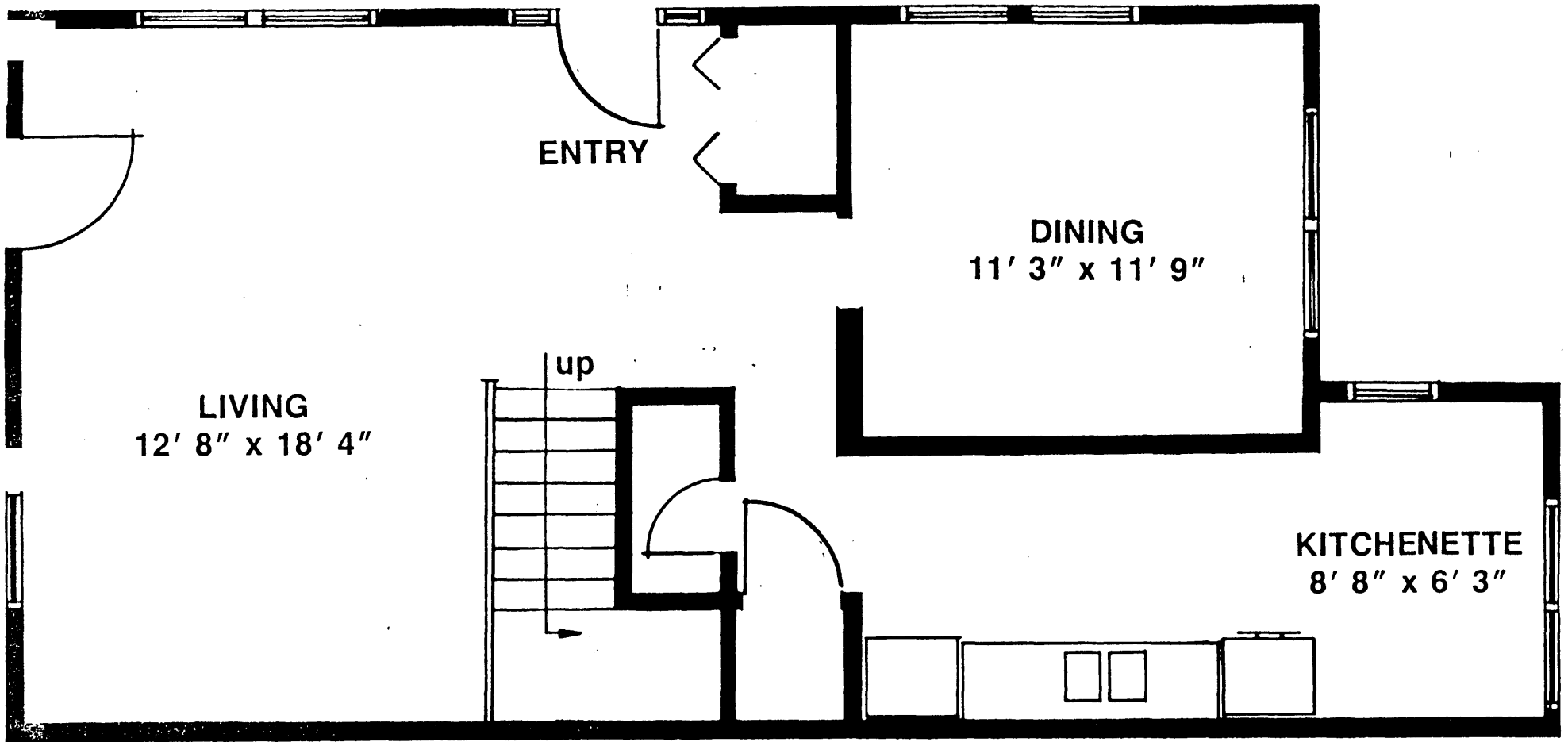

LIVING
12' 8" x 18' 4"

ENTRY

DINING
11' 3" x 11' 9"

KITCHENETTE
8' 8" x 6' 3"

up

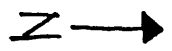

Unit D
1st floor

BALMORAL
4 BEDROOM/DEN/2 BATH TOWNHOUSE
1973 sq. ft.

PLAN - 4

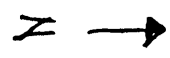
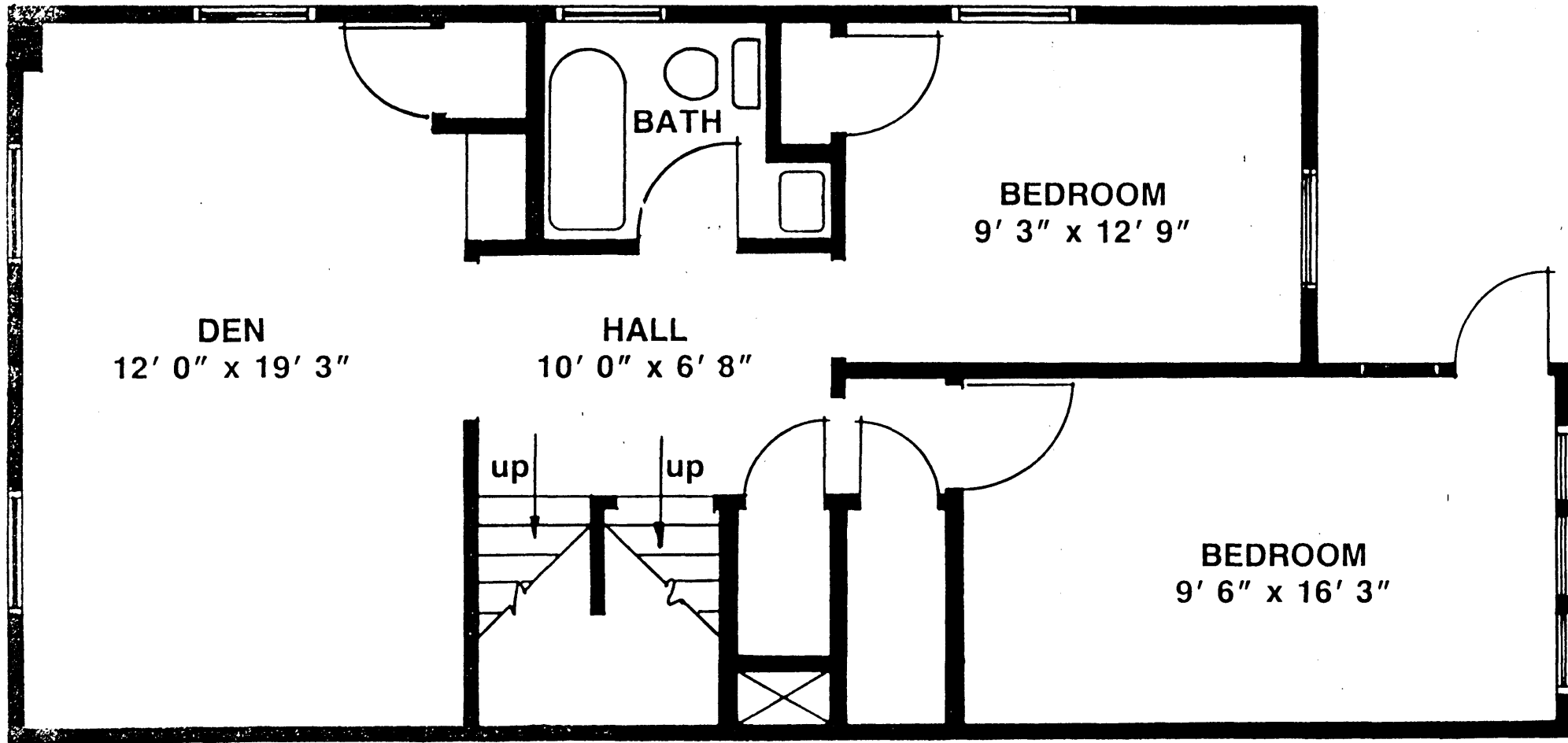

Unit D
(2nd floor)

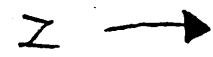
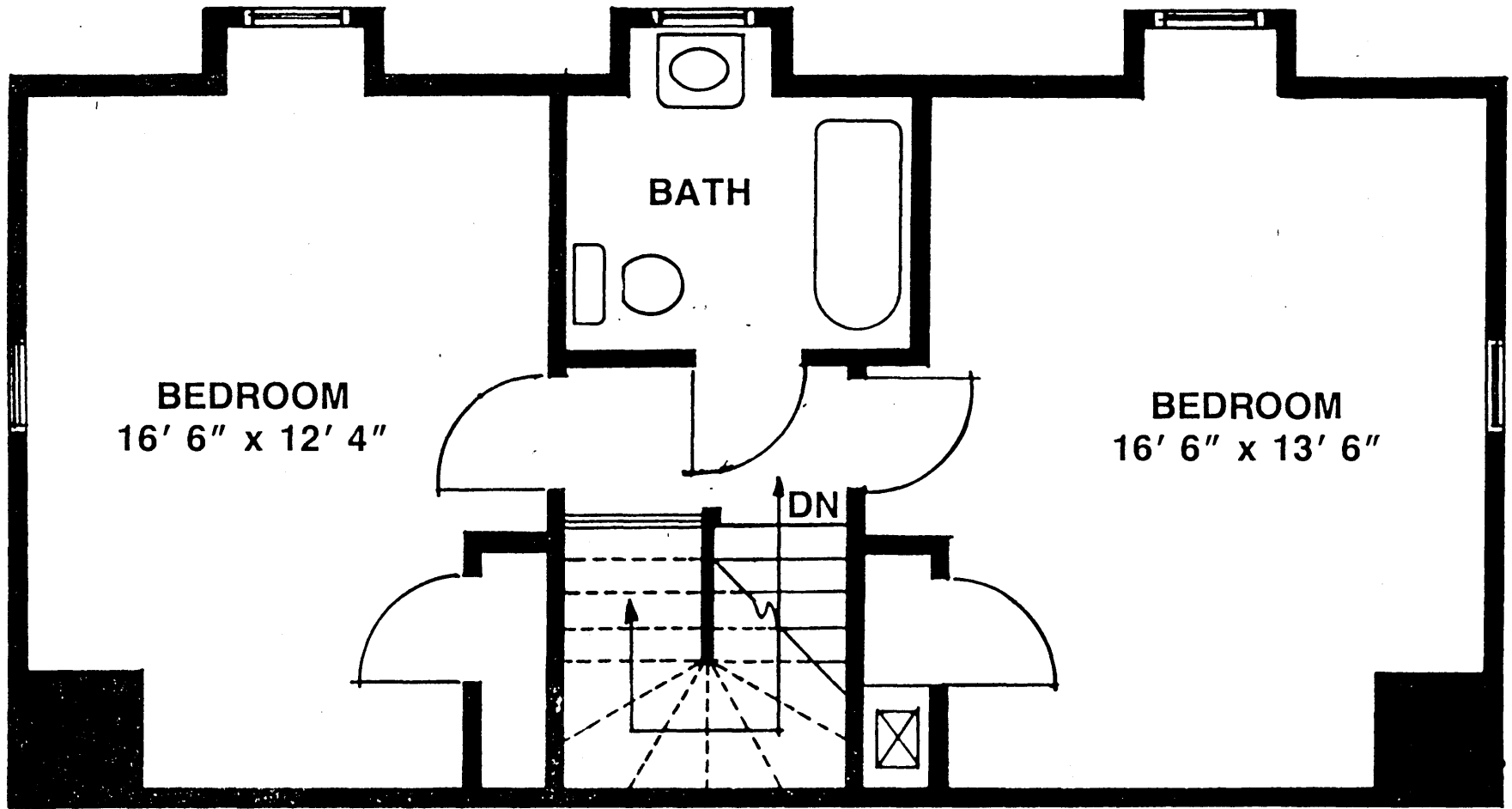

Unit D
(3rd floor)

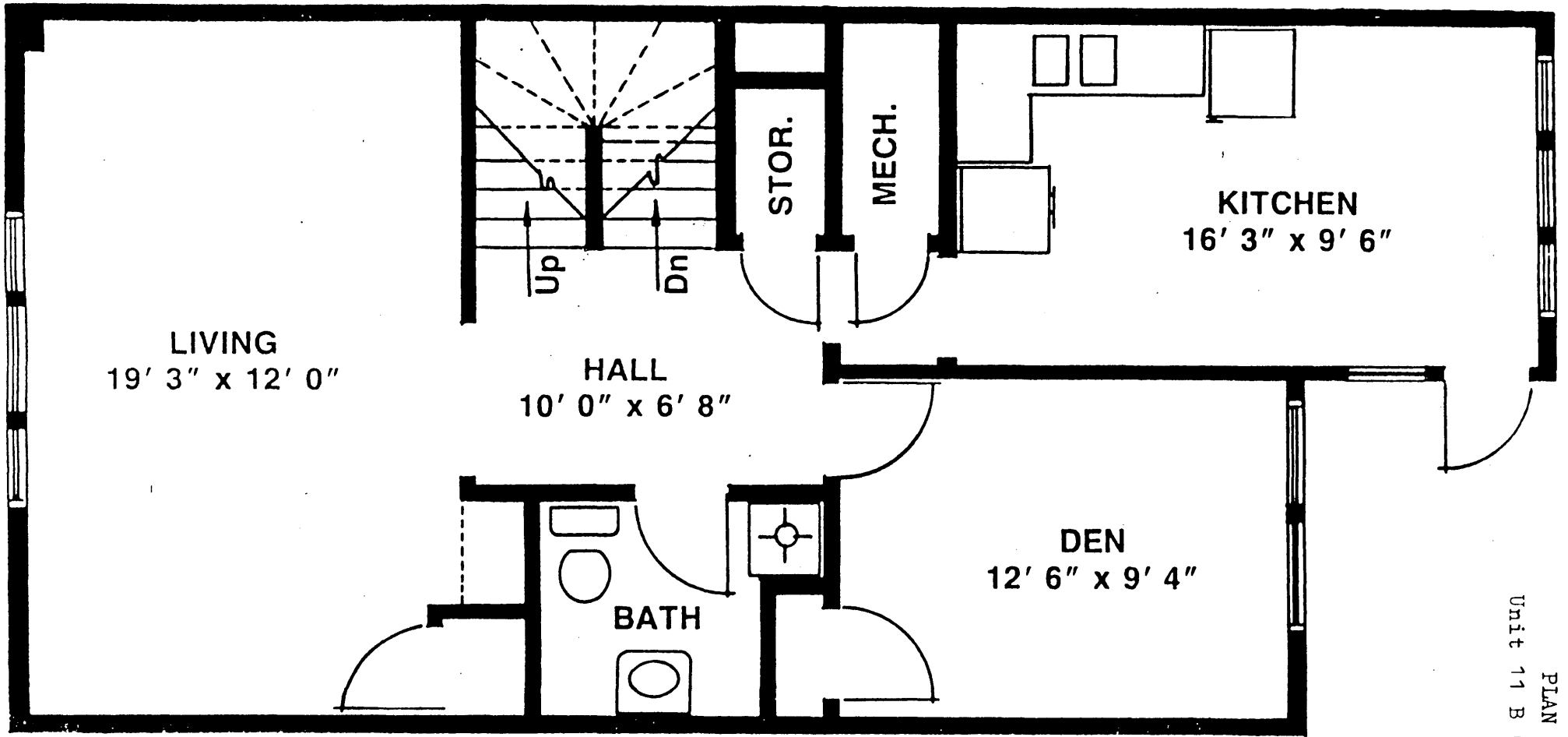

LIVING
19' 3" x 12' 0"

HALL
10' 0" x 6' 8"

KITCHEN
16' 3" x 9' 6"

DEN
12' 6" x 9' 4"

BATH

STOR.

MECH.

BALMORAL
2 BEDROOM/DEN/2 BATH TOWNHOUSE
1280 sq. ft.

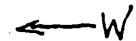

PLAN - 7
Unit 11 B (reversed)

PLAN - 8

Unit 11 B (reversed)
4th floor

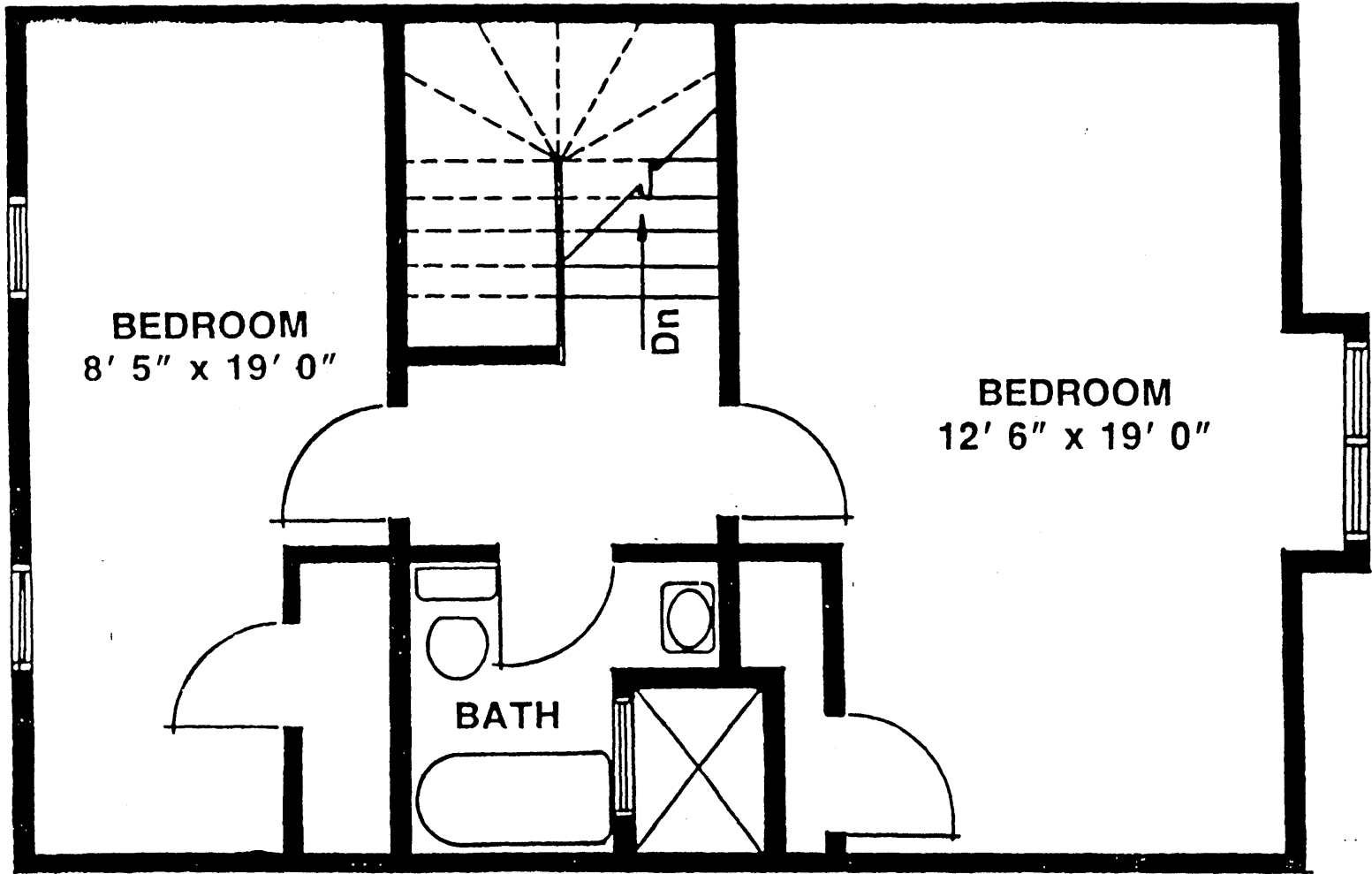
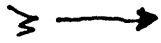

BALMORAL APARTMENTS

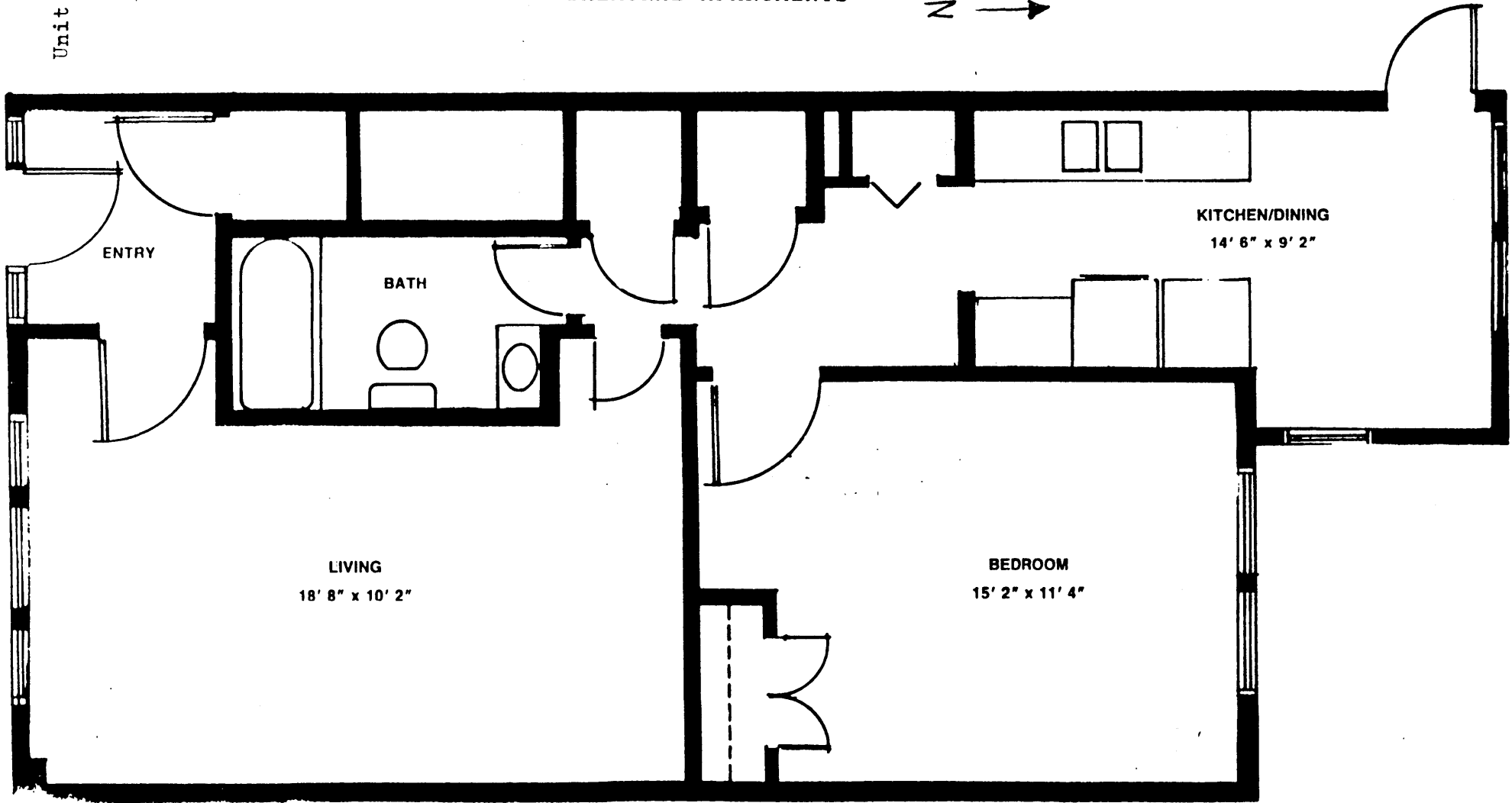
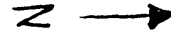

SECOND FLOOR

ONE BEDROOM

APPROX. 1200 sq. feet

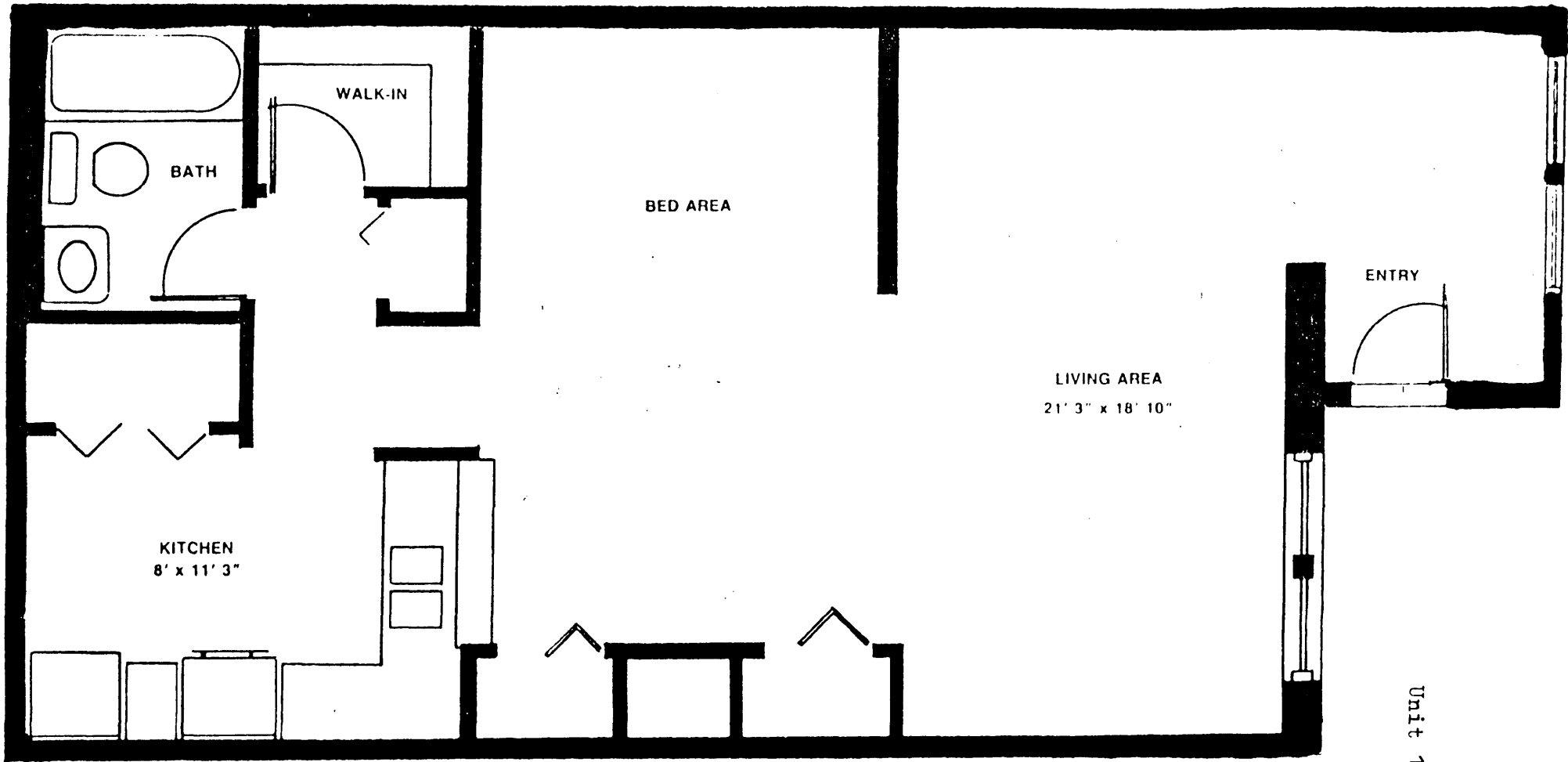

BALMORAL
STUDIO PLAN
600 sq. ft.

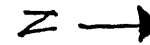

Unit 11L

Unit 10 A
(Lower Level)

