

Resub

RECEIVED



OMB No. 1024-0018

NPS Form 10-900 (Rev. 10-90)

United States Department of the Interior National Park Service

National Register of Historic Places Nomination Form

This form is for use in nominating or requesting determinations for individual properties and districts. See instructions in How to Complete the National Register of Historic Places Registration Form (National Register Bulletin 16A). Complete each item by marking "x" in the appropriate box or by entering the information requested. If any item does not apply to the property being documented, enter "N/A" for "not applicable." For functions, architectural classification, materials, and areas of significance, enter only categories and subcategories from the instructions. Place additional entries and narrative items on continuation sheets (NPS Form 10-900a). Use a typewriter, word processor, or computer, to complete all items.

1. Name of Property

Historic name Our Mother of Sorrows Grotto Historic District
other names/site number Our Mother of Sorrows Grotto, Our Lady of Sorrows Grotto, Mount Mercy Grotto

2. Location

street & number 1330 Elmhurst Dr. NE vicinity N/A Not for publication: N/A
City: Cedar Rapids state Iowa code IA county Linn code 113 zip code 52403

3. State/Federal Agency Certification

As the designated authority under the National Historic Preservation Act of 1986, as amended, I hereby certify that this x nomination request for determination of eligibility meets the documentation standards for registering properties in the National Register of Historic Places and meets the procedural and professional requirements set forth in 36 CFR Part 60. In my opinion, the property x meets does not meet the National Register Criteria. I recommend that this property be considered significant nationally statewide locally x. (See continuation sheet for additional comments.)

Signature of certifying official [Handwritten Signature]

Date 17 Nov. 2014

State Historical Society of Iowa
State or Federal agency and bureau

In my opinion, the property ___ meets ___ does not meet the National Register criteria. (___ See continuation sheet for additional comments.)

Signature of commenting or other official

Date

State or Federal agency and bureau

4. National Park Service Certification

I, hereby certify that this property is:

- entered in the National Register
determined eligible for the National Register
determined not eligible for the National Register
from the National Register
other (explain):

Signature of Keeper

[Handwritten Signature: Patrick Anderson]

Date of Action

[Handwritten Date: 1/21/2015]

Our Mother of Sorrows Grotto Historic District
Name of Property

Linn County, Iowa
County and State

5. Classification

Ownership of Property

(Check as many boxes as apply)

- private
- public-local
- public-State
- public-Federal

Category of Property

(Check only one box)

- building(s)
- district
- site
- structure
- object

Number of Resources within Property

(do not include previously listed resources in count)

Contributing	Noncontributing	
_____	_____	buildings
_____	2	sites
4	1	structures
1	1	objects
5	4	Total

Name of related multiple property listing

(Enter "N/A" if property is not part of a multiple property listing.)

N/A

Number of contributing resources previously listed in the National Register

0

6. Function or Use

Historic Functions

(Enter categories from instructions)

Religion/religious facility

Recreation and Culture/ work of art

Current Functions

(Enter categories from instructions)

Religion/religious facility

Recreation and Culture/outdoor recreation

Work In Progress

7. Description

Architectural Classification

(Enter categories from instructions)

OTHER: Visionary Art

OTHER: Grotto

Materials

(Enter categories from instructions)

foundation Concrete
Stone/ marble
Stone/ granite
Stone/limestone
Walls Concrete
Glass
Ceramic tile
Stone/ marble
Stone/ granite
roof Stone

Narrative Description _____ (Describe the historic and current condition of the property on one or more continuation sheets.)

Our Mother of Sorrows Grotto Historic District
Name of Property

Linn County Iowa
County and State

8. Statement of Significance

Applicable National Register Criteria

(Mark "x" in one or more boxes for the criteria qualifying the property for National Register listing)

- A** Property is associated with events that have made a significant contribution to the broad patterns of our history.
- B** Property is associated with the lives of persons significant in our past.
- C** Property embodies the distinctive characteristics of a type, period, or method of construction or represents the work of a master, or possesses high artistic values, or represents a significant and distinguishable entity whose components lack individual distinction.
- D** Property has yielded, or is likely to yield information important in prehistory or history.

Criteria Considerations

(Mark "X" in all the boxes that apply.)

Property is:

- A** owned by a religious institution or used for religious purposes.
- B** removed from its original location.
- C** a birthplace or a grave.
- D** a cemetery.
- E** a reconstructed building, object, or structure.
- F** a commemorative property.
- G** less than 50 years of age or achieved significance within the past 50 years.

Narrative Statement of Significance

(Explain the significance of the property on one or more continuation sheets.)

9. Major Bibliographical References

Bibliography

(Cite the books, articles, and other sources used in preparing this form on one or more continuation sheets.)

Previous documentation on file (NPS)

- preliminary determination of individual listing (36 CFR 67) has been requested.
- previously listed in the National Register
- previously determined eligible by the National Register
- designated a National Historic Landmark
- recorded by Historic American Buildings Survey

Areas of Significance

(Enter categories from Instructions)

Art

Architecture

Period of Significance

1929-1941

Significant Dates

1929

Significant Person

(Complete if Criterion B is marked above)

N/A

Cultural Affiliation

Builder

Lightner, William H.

Our Mother of Sorrows Grotto Historic District
Name of Property

Linn County, Iowa
County and State

Name of repository: Mount Mercy Univ., Busse Library, Special Collections

10. Geographical Data

Acreage of Property .75 acres

UTM References

(Place additional UTM references on a continuation sheet)

	Zone	Easting	Northing	Zone	Easting	Northing
1	<u>15</u>	<u>611522</u>	<u>4650962.0</u>	3	<u> </u>	<u> </u>
2	<u> </u>	<u> </u>	<u> </u>	4	<u> </u>	<u> </u>

Verbal Boundary Description

(Describe the boundaries of the property on a continuation sheet.)

See continuation sheet.

Boundary Justification

(Explain why the boundaries were selected on a continuation sheet.)

11. Form Prepared By

name/title Professor Jane Gilmor e-mail: janegilmor@yahoo.com
organization Mount Mercy University date July 1, 2013
street & number 358 Trailridge Road SE telephone 319-651-3973 (cell)
city or town Cedar Rapids state Iowa zip code 52403

Additional Documentation

Submit the following items with the completed form:

Continuation Sheets

Maps: A **USGS map** (7.5 or 15 minute series) indicating the property's location.

A **sketch map** for historic districts and properties having large acreage or numerous resources.

Photographs: Representative **black and white photographs** of the property.

Additional items

(Check with the SHPO or FPO for any additional items)

Property Owner

(Complete this item at the request of the SHPO or FPO.)

name Mount Mercy University Contact name: Walter Chien, wchien@mtmercy.edu
street & number 1330 Elmhurst Drive NE telephone 319-363-8213
city or town Cedar Rapids state IA zip code 52402

Paperwork Reduction Act Statement: This information is being collected for applications to the National Register of Historic Places to nominate properties for listing or determine eligibility for listing, to list properties, and to amend existing listings. Response to this request is required to obtain a benefit in accordance with the National Historic Preservation Act, as amended (16 U.S.C. 470 et seq.).

Estimated Burden Statement: Public reporting burden for this form is estimated to average 18.1 hours per response including the time for reviewing instructions, gathering and maintaining data, and completing and reviewing the form. Direct comments regarding this burden estimate or any aspect of this form to the Chief, Administrative Services Division, National Park Service, P.O. Box 37127, Washington, DC 20013-7127; and the Office of Management and Budget, Paperwork Reductions Project (1024-0018), Washington, DC 20503.

7. Narrative Description

GENERAL DESCRIPTION

**United States Department of the Interior
National Park Service**

**National Register of Historic Places
Continuation Sheet**

Section 7 **Page** 5 **Property name** Our Mother of Sorrows Grotto

County and State Linn County, Iowa

Contractor, builder and visionary artist William H. Lightner built the Our Mother of Sorrows Grotto complex on the campus of Mount Mercy University (then Mount Mercy Academy) over a period of twelve years between 1929 and 1941. The Sisters of Mercy, who owned and located their Sacred Heart Convent and the Academy on the property, commissioned Lightner to build "a small grotto" in 1927. (Roth, p. 49) The Grotto complex was dedicated in 1941 after the Sisters of Mercy brought a lawsuit against Lightner to stop building on the site.

The Mount Mercy University campus occupies a hill near the center of Cedar Rapids, Iowa in its northeast quadrant. Originally Lightner's Grotto included five major structures in a park surrounding a lagoon. It now has four of the five original structures centered around a new central pond and his Ten Commandments shrine, which floats on an island in the pond. The boundaries of the property being nominated are depicted in Figure #1 using a dark black outline to enclose the area.

The site of the Mount Mercy University campus is on one of the highest points in Linn County. Once known as Mound Farm and more familiarly as the Mound View neighborhood, it was outside the city limits when purchased by the Sisters of Mercy in 1906. It is now considered close to the center of Cedar Rapids. It is approximately two miles northeast of the city center. The 44.5-acre site of the University is bordered on all sides by blocks of single-family dwellings. First Avenue, the main thoroughfare of the city is .6 miles to the southwest of the site and Interstate Highway 380 runs north/south just .5 miles to the west of the site.

William Lightner's original design and the grotto site as it now exists, with the unifying element of the New Pond, are firmly related to Father Paul Dobberstein's Grotto of Redemption in West Bend, Iowa (on the National Register since 2003). Using Dobberstein's example, Lightner consistently used exotic, natural stone and the finest tile and statuary available from Italy. Lightner was skilled in glass mosaic and stone inlay and in masonry. His tile work is done without grout using quarter and half-inch Italian smalti glass tiles.

Lightner built his structures of reinforced concrete, masterfully embellished with a range of stones, tile, and petrified woods. He traveled over 40,000 miles collecting over twelve hundred tons of rocks and three hundred different kinds of semi-precious stones gathered from throughout the United States and Mexico. The Grotto's four remaining structures reveal Lightner's exceptional sense of visual design as well as providing a multitude of geological specimens, including coral from Hawaii, petrified wood, lapidolite, white quartz, blue azurite, and rose quartz from Colorado and the Black Hills. It is noteworthy that Lightner constructed the entire Grotto complex at his own expense (\$45,000 for materials in addition to his twelve years of daily labor) and with only minimal use of assistants. He contacted suppliers worldwide in search of the more than three hundred varieties of mosaic tiles used.

United States Department of the Interior
National Park Service

National Register of Historic Places
Continuation Sheet

Section 7 Page 6 Property name Our Mother of Sorrows Grotto
County and State Linn County, Iowa

As part of his Grotto, Lightner created two commanding Roman entry arches (known as the Warde Arch and the McAuley Arch) connecting the Grotto to the larger campus. In addition, he built an elaborate Bridge over a pond-like extension of the lagoon (non-extant) and a temple-like Ten Commandments monument. All the structures are ornamented with phrases expressing Catholic devotion and mottos regarding the Virgin Mary as the Mother of Sorrows.

A noteworthy aspect of the original complex was the Central Wall Shrine (non-extant). As will be discussed later, the term *grotto* can be misleading. The Wall Shrine was not the actual "grotto" for Lightner's site or the architectural imitation of a cave (as grotto shrines in Europe centuries earlier would have been). Rather, it was a long lava rock wall completed in 1941 and containing a central shallow niche designed to hold a marble statue of the Virgin Mary. The statue itself did not arrive, however, until after World War II in 1949. The Virgin Mary statue was and remains a focal point, referencing Lightner's inspiration for the project. Thus, the label *grotto* in Our Mother of Sorrows Grotto refers to the entire site, all created by Lightner in honor of the Virgin Mary represented as Our Sorrowful Mother.

SITE

William Lightner's Our Mother of Sorrows Grotto and Grotto Park is now located on .75 acres of land comprising an area near the western boundary of Lot 1, Block I of the Mound Farm subdivision of Northeast Quadrant of Cedar Rapids, Iowa. Located on Mount Mercy University's 44.5 acre campus on a rise directly East of Interstate Highway 380 (north/south between Waterloo and Cedar Rapids) and west of State Highway 151 (southwest to northeast between Cedar Rapids and Anamosa), the site is bounded by Elmhurst DR. NE to the west, 27th Street NE to the north, K Avenue NE to the south and Prairie Drive NE to the East. A vehicular drive enters the site from Elmhurst Drive to the west and allows entry to the parking lot next to the Grotto. This is delineated in Figure #1 and in the larger campus maps of Figure #4 as well as the plat map in Figure #5

**United States Department of the Interior
National Park Service**

**National Register of Historic Places
Continuation Sheet**

Section 7 Page 7 Property name Our Mother of Sorrows Grotto

County and State Linn County, Iowa

Extant Grotto Structures: status, dates, photo & figure references

#	NAME OF STRUCTURE	Resource Type	STATUS	DATE	PHOTO / FIG. NO.
#1	McAuley Arch	Structure	Contributing	1929-41	Photo #20, 21,22,23 Fig #6,13
#2	Grotto Bridge	Structure	Contributing	1929-41	Photo #1, 2, 4,5,11,12, 13,14,15,16 Figure #7, 10,11,12, 13, 14,16,21
#3	Ten Commandments	Structure	Contributing	1929-32	Photo #1,2,3, 4,5,6,7,8,9, 12,24,29 Figure #8, 10,12,13,14, 20,21
#4	Warde Arch	Structure	Contributing	1929-32	Photo #10,17,18,19,29 Figure #9,10,17
#5	New Pond	Site (Integral to larger site)	Non-contributing	2002	Photo #1,2,3,4, 5,11,12,24,25,29 Figure #21
#6	Marble Statue of Virgin Mary	Object	Contributing	1949	Photo #1,2,12, 24,25,26,27,29 Fig #18,21
#7	New Canopy Structure for Virgin Statue	Structure	Non-contributing	2004	Photo #1,2,12,24,25, 26,27 Fig.#21
#8	Walkways and Gardens including Walk of Mercy	Site (Integral to larger site)	Non-contributing	2002	Photo #1,2,3, 4,5,10,12,14, 21,24,25,29 Fig.#21
#9	Didactic Plaque	Object	Non-contributing	2001	Photo #28

United States Department of the Interior
National Park Service

National Register of Historic Places
Continuation Sheet

Section 7 Page 8 Property name Our Mother of Sorrows Grotto

County and State Linn County, Iowa

Description of Extant Grotto Structures

#1 McAuley Arch (Contributing) See Photos # 20, 21, 22, 23; Figures # 6, and 13

Both of the Grotto arches, McAuley Arch and Warde Arch, function as symbolic architectural monuments and circulation features, marking the approach to the pond landscape from two primary east/west axes of the campus. The words *AND THE VIRGIN'S NAME IS MARY* are spelled out in white stone on a black stone background on the east arch face. The words *HAIL FULL OF GRACE THE LORD IS WITH THEE* are spelled out in white stone on the west arch face. The arch is 18 ft. h. x 14 ft. w. x 5 ft. d. The interior of the arch is meticulously inlaid with smaller stone mosaic rosettes and other patterns made up of small sections of rose quartz, white quartzite, and multiple other semi-precious stones. Two embellished urns with tile-covered lids are placed atop the east and west corners of each. A new walkway, The Walk of Mercy (2011), leads up the hill to McAuley Hall and the new University Center and/or back down the hill to the Grotto pond and the Grotto structures surrounding it. The arch is nearly identical to the Warde Arch in design, proportions, and surface embellishment and is in nearly perfect condition following the restoration work of 2012-13.

#2 The Grotto Bridge (Contributing)

See Photos #1, 2, 4, 5, 10, 11, 12, 13, 14, 15, 16 and Figures # 7,10, 11, 12, 13, 14, 16, 21

The Grotto Bridge rests on an embellished stone arch over a narrow crossing of the New Pond. The closed spandrel surfaces above the stone arch span are yellow and black checkerboard glass tile, with green glass tile in the center. The Bridge deck is built of freeform interlocking stone and supports two flanking columns at each end. The columns on each side of the Bridge support two flanking open-air canopy arches, connected by a span at the center. The span is topped by a flower basket finial, with five rock and tile mosaic embellished flowers. The words *BUT WITHOUT FAITH IT IS IMPOSSIBLE TO PLEASE GOD* are spelled out in gold tile against a red background on the northeast facing span and the words *MY GRACE IS SUFFICIENT FOR THEE* are spelled out in gold tile against a red background on the southwest facing span. The Bridge is a symbolic architectural feature, representing Lightner's crossing over into the Catholic faith, and is a central focal point and circulation feature, leading over the pond and framing a view of the central Ten Commandments monument and the surrounding landscape.

The Grotto Bridge is 18 ft. high by 5 ft. wide by 15 ft. long, not including the embellished railings along the walkways leading up to it on either side. The Bridge can be entered on the southwest or northeast sides and traverses a small section near the west end of the Grotto's New Pond (2002). The Bridge has

United States Department of the Interior
National Park Service

National Register of Historic Places
Continuation Sheet

Section 7 Page 9 Property name Our Mother of Sorrows Grotto

County and State Linn County, Iowa

a concrete walkway leading to the structure. This walkway has three original embellished railing posts supporting two gently drooping embellished fence rails, flanking both sides of the path leading from the northeast to the Bridge. Two embellished posts support single gently swaging fence rails flanking the path leading from the Student Apartments Parking Lot "N" to the southwest entrance of the Bridge. Concrete posts (six total) were added under the center of each fence rail, to provide support that was presumed to be necessary in the 2002 Smithsonian Institution American Heritage Preservation Grant restoration project. The southwest railings are 11 ft. long and the northeast railings are 18 ft. long. The concrete walkway is 4 ft. wide.

#3 Ten Commandments Monument (Contributing)

See Photos # 1, 2, 3, 4, 5, 6, 7, 8, 9, 12, 24, 29 and Figures # 8, 10, 12, 13, 14, 20, 21

Lightner consistently used exotic natural stone and the finest tile and statuary available from Italy. He did not use found materials and broken crockery like some grotto builders. The Ten Commandments structure is indebted to Classical Roman architecture but also to a fair amount of visionary fantasy which is so eccentric in form as to reference everything from a Hindu shrine to an elaborate birthday cake. Indeed, the Ten Commandments monument is a symbolic architectural temple to Moses' Decalogue, an anchor of Catholic faith and a focal point of Lightner's Grotto. This structure best demonstrates Lightner's vision as an artist and a skilled mosaic craftsman.

The Ten Commandments monument consists of a rectangular plinth or base resting on a small rock island in the New Pond. The structure is 18 ft. high and 8 ft. x 10 ft. at its base. The monument's roof and base are inlaid with large and small semi-precious stones. Each of the four sides of the base has an Italian glass mosaic spelling out several of the Ten Commandments. Embellished concrete columns rise from the base, four on each long side with one in the center of each short side. As capital decoration each column has the Roman numerals corresponding to one of the commandments. The columns support Roman arches that support a cornice. Above is a three-tiered roof supporting a twenty-inch diameter Italian gold mosaic globe restored in 2013. The truly unique design of this structure and its skillfully created glass tile mosaics, along with the beautiful architectural proportions of the structure and its location on an island in a pool, make this work Lightner's most impressive and the true center of emphasis.

4 Warde Arch (Contributing)

See Photos #10, 17, 18, 19, 29 and Figure # 9, 10, 17

Leading to the original Grotto site and the current lot surrounding the pond is the Warde Arch. A walk way leads from Warde Hall (also built by Lightner) 50 ft. northeast to the Student Apartment Parking

**United States Department of the Interior
National Park Service**

**National Register of Historic Places
Continuation Sheet**

Section 7 Page 10 Property name Our Mother of Sorrows Grotto

County and State Linn County, Iowa

Lot "N" to the west of the Grotto's New Pond. Upright flanking sidewalls support a Roman arch. The arch opens to the North and South and is 18 ft. high by 14 ft. wide by 5 ft. deep. The arch opening is seven foot wide and is bridged by reinforced concrete inlaid with large stones and petrified wood.

The interior of the arch is meticulously inlaid with a smaller stone mosaic rosettes and other patterns made up of small sections of rose quartz, white quartzite, and multiple other semi-precious stones. Two embellished urns with tile-covered lids are placed atop the north and south corners of each upright sidewall. The words *BLESSED ART THOU AMONG WOMEN* are spelled out in white stone on the south arch face. The words *AND THERE STOOD BY THE CROSS OF JESUS HIS MOTHER* are spelled out in white stone on the north arch face. An embellished cross is mounted on the top center of the arch. A concrete sidewalk and steps lead to the Arch from the drive between the Warde Arch and Warde Hall, and continues down to a footpath to the Grotto Bridge and to the Student Apartment Parking Lot N.

In 2011-2012 the Warde Arch was completely restored with the help of an Iowa Arts Council Grant. Deteriorating cement on the top of the arch, loose rocks, and missing tiles were replaced. Bolts were added to secure some large stones. Mortar following Lightner's original recipe was used. The words on either side of the arch had missing stones replaced and the four jardinières atop the arch were also retiled. The entire structure was first cleaned and then sealed after this restoration and conservation using The Secretary of the Interior's Standards and Guidelines for Restoration.

5 The New Grotto Pond (Non-contributing)

See Photos # 1, 2, 3, 4, 5, 11, 12, 24, 25, 29 and Figures #21

During the 2001-2002 restoration project a smaller and shallower New Pond was put in place inside the footprint of an extension of the original lagoon. The New Pond is a kidney shape approximately 140 feet long by 40 feet at its widest point, and about one foot deep. It is about one third the size of the original Lagoon and is actually constructed within the footprint of the original side pond that attached to the Lagoon. The New Pond addition brought unity and a central focus to the four remaining Grotto structures. Once again the Ten Commandments is an island in the pond and the Bridge actually traverses water. The pond has two waterfalls for circulation and to enhance the atmosphere of peaceful commune with nature. It is surrounded by plantings and by large lava stones from the original Wall Shrine (non-extant) recovered from the excavations done into the old lagoon footprint when creating the New Pond.

United States Department of the Interior
National Park Service

National Register of Historic Places
Continuation Sheet

Section 7 Page 11 Property name Our Mother of Sorrows Grotto

County and State Linn County, Iowa

6 Virgin Mary Italian Marble Sculpture (Contributing)

See Photos # 1, 2, 12, 24, 25, 26, 27 and 29 and Figures # 18 and 21

The Wall Shrine of Lightner's Grotto was built with a central niche intended to house a marble statue of the Virgin Mary honoring the inspiration for Lightner's Grotto. The Italian Carrara marble statue of the Virgin Mary, commissioned in 1941 by The Sisters of Mercy (at Lightner's earlier suggestion) was carved by Marcella Rebecchini at the Daprata Studios in Pietrasanta, Italy, but was not installed until 1949, after World War II. It was standard practice in the early and mid-twentieth century for important Catholic cathedrals and shrines to order such marble statues from the companies of skilled stone carvers located at the marble quarries once used by Michelangelo. The Grotto's statue of the Virgin, depicted as Our Mother of Sorrows, is five feet tall with a one-foot high by two-foot square marble base. During the 1960s vandals damaged the statue's nose and hands. Following the removal of the Wall Shrine in the early 1970s, the statue was stored in the University's Art Department until it was repaired and reinstalled in the New Canopy Shrine Structure in 2004. Though it has been moved, this Virgin Mary statue remains a central focus of the Grotto.

7 New Canopy Shrine Structure (2004, Non-contributing) housing the original Virgin Mary statue

See Photos # 1, 2, 12, 24, 25, 26, 27, 29 and Figure #21

As noted above, the New Canopy Shrine Structure was built to house the Virgin Mary statue previously housed in the Wall Shrine. Built by Rick Edelman, a local artist, mason and craftsman, the New Canopy Shrine is an 8 ft. square open-air structure with a stone floor and four embellished concrete columns supporting a cross gabled roof over a groin vault ceiling, all embellished with stone inlay. The Virgin statue is installed within. The craftsmanship is outstanding and evokes Lightner's design and embellishment style very closely, according to grotto conservators Lisa Stone and Don Howlett. The shrine is situated on a stone pathway about halfway up the hill to the east of the pond. This unifying pathway becomes the Walk of Mercy connecting the Grotto via the McAuley Arch to the new University Center.

8 Walkway System, including the Walk of Mercy (2011, non-contributing)

See Photo #'s 1, 2, 3, 4, 5, 10, 12, 14, 21, 24, 25, 29 and Figures # 21

The Grotto's five existing structural elements are connected by curving stone and concrete paths and are set among commanding mature cedar and pine trees and gardens with classic Midwestern plantings based on archival photos of the Grotto grounds. A new set of concrete walkways and steps named the Walk of Mercy, built in 2011, leads from the McAuley Arch to the new University Center and central campus Quad (2011). From the McAuley Arch a walkway proceeds down to the New Canopy

United States Department of the Interior
National Park Service

National Register of Historic Places
Continuation Sheet

Section 7 Page 12 Property name Our Mother of Sorrows Grotto
County and State Linn County, Iowa

Shrine Structure containing the original Virgin Mary Statue. From there a stone path continues along the east side of the New Pond around the Ten Commandments monument and across the Grotto Bridge, circling back to the Walk of Mercy and University Center or west to the Warde Arch and Warde Hall. The entire walkway connects the five existing structures to each other and to the Pond. The New Pond is central to the site giving unity to all aspects of the Grotto while putting the major focus on Lightner's masterpiece, the Ten Commandments monument.

9 Interpretive Plaque (non-contributing) See Photo 28

An anodized aluminum interpretive plaque (24 x 36 in.) is mounted at reading level near the walkway leading down to the Grotto complex from Warde Hall to the north. Installed during the 2001-02 Smithsonian American Heritage S.O.S.! (Save Outdoor Sculpture) restoration project, the plaque provides visitors with a photographic and textual overview of the site's history and its original features prior to the draining of the Lagoon and the removal of the Wall Shrine. In 2001 three new park benches were created to replicate originals seen in photographs of the site, using the last remaining original as a prototype. These are situated, respectively, on the southwest side of the Ten Commandments monument, above the northeastern pond garden, and west of The Grotto Bridge.

Description of Non-extant Elements

Lagoon (Non-extant) See Figures # 1, 3, 4, 16, 18, 21

The original Grotto Lagoon included what are now parts of both Student Apartment Parking Lots N and S (North and South) for the current Student Apartments (built in 1976 and scheduled for removal in 2014-16). A partial view of the student four-plex apartments can be seen behind the Warde Arch in Photo 18 and the two Apartment Parking Lots, N and S, are designated in Figures 1 and 3. The Lagoon went up to the Warde Arch on the north side and to the Wall Shrine (non-extant) on the south side. The Wall Shrine occupied what is now the Student Apartment building closest to Warde hall and to the Elmhurst Drive entrance to the University. To the east The Ten Commandments Monument is actually in the water near the eastern boundary of the New Pond attached to the original lagoon. The Bridge traverses a small extension of the pond that includes the Ten Commandments. We estimate the lagoon was a circle with a 60 ft. diameter and 6 ft. deep - enough for canoeing and swimming.

United States Department of the Interior
National Park Service

National Register of Historic Places
Continuation Sheet

Section 7 Page 13 Property name Our Mother of Sorrows Grotto

County and State Linn County, Iowa

The Central Wall Shrine (Non-extant)

See Figures #1, 15, 18

The Central Wall Shrine built to house the Our Mother of Sorrows (Virgin Mary) marble statue was created and built by Lightner between 1932 and 1941. He worked on the large rock wall shrine on and off while constructing the other Grotto buildings. Though Lightner began with a plan, like most visionary artist builders (Dobberstein, in particular), he felt free to alter and add to the original plan at will.

The Wall Shrine curved slightly to conform to the southeast shore of the Lagoon. The wall is estimated to have been 17 feet high (including the four jardinières on top), approximately 40-50 ft. long and 4 to 5ft. deep. The wall structure had a shallow indented central niche built to house the marble Virgin Mary. On either side of the niche for the statue were mosaic tile inlays representing four images of the Stations of the Cross (Seven Sorrows of Our Mother). The remaining three stations were on the backside of the wall, facing McAuley Hall. The majority of the structure was reinforced concrete embedded with huge lava rocks rather than the small ornate rock inlay designs skillfully applied to the other structures of the Grotto (the Bridge, The Ten Commandments and the two Arches). In 1974 the Wall Shrine was demolished after the Lagoon was drained in 1970 (two years after Lightner's death) because the Sisters of Mercy's were financially unable to maintain the site and the neighbors felt it a hazard to children playing. The site continued to be referred to as *The Grotto*, however.

HISTORIC INTEGRITY AND PRESENT CONDITION OF GROTTO DISTRICT

William H. Lightner 's Our Mother of Sorrows Grotto is now in excellent condition and the existing original structures remain nearly as they were built. The Grotto area topography, setting, and design, including the materials and craftsmanship, are almost exactly as Lightner created them with the exception of the Lagoon and the Wall Shrine. A smaller pond replaced the original Lagoon in 2001. The 1975 addition of four small student apartment complexes (with parking lots) just 300 feet south of the remaining Grotto structures could also be considered a distraction from the original grotto site. These are now scheduled for removal in 2016, however.

As discussed later, the term "grotto" can be confusing. The Wall Shrine housing the inspiration for the site, the Virgin Mary marble statue, was not the actual "grotto," but was one of five structures surrounding the lagoon/pond area and comprising the site known as "The Grotto." Indeed, 1930's photographs of the site, as it was being constructed, label images of the Ten Commandments monument (not the Wall Shrine) as "The Mother of Sorrows Shrine" or "The Mother of Sorrows Grotto" (MMU Busse Library Archives). Lightner's grotto, as it is seen today, has been without the Wall

United States Department of the Interior
National Park Service

National Register of Historic Places
Continuation Sheet

Section 7 Page 14 Property name Our Mother of Sorrows Grotto

County and State Linn County, Iowa

Shrine since 1974 and as such has come to be visually identified as "The Grotto" based on its current organization of original structures. For these past four decades the site has continued to be visited, researched and written about, by both laypersons and academics, as a Midwestern "grotto" of major significance built by a master designer and builder.

Despite the changes noted above, there is major support for the site's application for the National Register (and for its integrity as *a grotto*.) Two scholars and national authorities on Midwestern Visionary Architecture and Environments have recently sent letters to support the integrity of the Lightner Our Mother of Sorrows Grotto District, as it exists today, centered around the New Pond and original Ten Commandments monument (Lightner's artistic masterpiece according to preservationists Anton Rajer and Lisa Stone). Both Lisa Stone and Dr. Susannah Koerber have visited the site multiple times and written past letters of support for all three of our major restoration grants. Both have also worked with various National Register commissions and committees in past years.

Lisa Stone, Professor in the Art History Department of The School of The Art Institute of Chicago and Curator for the Roger Brown Study Center at SAIC has written extensively on this topic, served as a restoration expert for the Kohler Foundation in Sheboygan, Wisconsin and has included discussions of Lightner's grotto in several of her academic articles. Her research and writing on Visionary Midwestern Architecture inform her statements related to the integrity of our grotto district. Stone notes that the term "grotto" can be misleading as "grotto" literally means a cave. Eighteenth century European grottos did often involve a natural or manmade cave-like structure. In her support letter of November 3, 2013, Stone explains:

While the term "grotto," from ancient and classical sources, referred to a shelter in a natural cave with some proximity to water as a place for spiritual repose or divination, the tradition of Catholic devotional grottos in the Upper Midwest in the 20th century expressed a broad building program, in which a range of structures, monuments, and objects, created out of elaborately embellished concrete, were referred to as grottos.

While it's unfortunate that the Mother of Sorrows Wall Shrine structure was demolished, I believe the site retains strong integrity through the preservation of the bridge, the two commanding arches, and the Ten Commandments monument. These structures possess outstanding architectural and aesthetic strength, while expressing Lightner's program of conveying aspects of faith by moving through beautiful structures placed within a natural landscape. The reintroduction of the lagoon (pond) element is especially critical to the site, which now allows for appreciation of the built elements within a cultivated garden and water feature.

United States Department of the Interior
National Park Service

National Register of Historic Places
Continuation Sheet

Section 7 Page 15 Property name Our Mother of Sorrows Grotto

County and State Linn County, Iowa

There are other sites on the National Register of Historic Places, as well as Wisconsin's Kohler Foundation's collection of visionary architecture sites, that are officially referred to as "grottos," but have no manmade caves and/or have major structures missing from the site. For example, The Ave Maria Grotto in Cullman, Alabama has no "cave reference" as part of the site but is referred to as a "grotto". The Paula and Matilda Wegner Grotto in Sparta, Wisconsin has no cave-like structures and the central focus of the original environment, the stone inlay covered family home, has been demolished. Similarly, the Rudolph Grotto Garden and Wonder Cave separates (in its title) the manmade cave on the site from the actual "grotto." Lisa Stone adds:

Many sites are listed in the National Register of Historic Places, even though elements are no longer extant. Fred Smith's Wisconsin Concrete Park (Phillips, WI) was listed in the NRHP in 2005 as a historic district (sculptures, house, and tavern) despite the fact that the site had been previously (several years earlier) hit by two major windstorms, which demolished major elements. Sculptures and tableaux had to be moved from their original location on the tavern property into the park, and significant alterations were made to the tavern. Sites such as this, including the Our Mother of Sorrows Grotto, have the power to convey their historical integrity through the sensitively preserved extant elements.

(Stone, November 3, 2013 letter)

Dr. Susannah Koerber is Senior Vice President of Collections and Interpretation for the Indiana State Museum and all of Indiana's historic sites, and the former Assistant Curator at The High Museum in Atlanta where she oversaw major work on Howard Finster's well-known visionary site Paradise Garden. Dr. Koerber researched Lightner's Grotto as part of her PhD dissertation in American Studies at Emory University investigating and comparing Midwestern Catholic grottos with Southern Protestant religious shrines, and has visited our site many times since the early 1990's. In her letter of support for this application she states:

We are fortunate that, although not complete, Lightner's original conception of the space and several of the major structures are in situ and have been carefully preserved. In my professional capacity, I am responsible for overseeing the Indiana State Museum and Historic Sites' statewide network of eleven sites and understand the importance of maintaining the integrity of landscapes and historic structures. The unity and function, as well as a significant number of the original structures, have survived in this case and are deserving of recognition for their aesthetic power, excellent and inspiring craftsmanship, and ability to continue to inform us about the grotto tradition.

(Koerber, November 2, 2013 letter)

**United States Department of the Interior
National Park Service**

**National Register of Historic Places
Continuation Sheet**

Section 7 Page 16 Property name Our Mother of Sorrows Grotto

County and State Linn County, Iowa

Three major grant awards for restoration since 2001 also help to substantiate the integrity of Lightner's Grotto: The 2012-2014 National Endowment for the Arts (NEA) *ARTWORKS* Grant (\$30,000) for restoration, the 2011 Iowa Arts Council (IAC) *Major Organizations Grant* for restoration (\$10,000), and the 2001 Smithsonian Institution American Heritage Preservation S.O.S.! *Save Outdoor Sculpture* Grant (\$10,000), also for restoration. Guidelines for each of these grants require the site (as it exists today) be a significant example of a type or style of architecture (the "grotto" style and form in Midwestern vernacular architecture) and be work with artistic merit and that of a master. They also require that all restoration accomplished with these grant funds meet the Secretary of the Interiors Standards for Restoration.

The 2012-14 NEA restoration grant had to be reviewed by Iowa's State Historic Preservation Office before the grant funds could be released to us. We prepared a Site Evaluation Form, which was approved. The SHPO staff then encouraged us to apply for the National Register based on the strength of our Site Evaluation Form.

The integrity of the site might also be confirmed by the fact that Linn County Historic Preservation Commission included Lightner's Grotto (with photos) on their *Historical Sites of Linn County* pamphlet (first published in 2004). In addition, SPACES (Saving and Preserving Arts and Cultural Environments) selected Lightner's Our Mother of Sorrows Grotto (as it exists today) in 2013 to be included on their web site based on its has artistic merit, integrity and historic significance. SPACES is a Los Angeles based, non-profit arts service and archive begun in the 1980's by Seymour Rosen, who is responsible for saving Simon Rodia's famous Watt's Towers (also in Los Angeles) and is a major figure in visionary environments and their preservation.

LOCATION: The Grotto district is located exactly where it was first built, on the highest point in Linn County just two miles Northeast of Cedar Rapid's city center and east of the Cedar River, between 27th Street NE and Elmhurst NE.

DESIGN: Through the larger Lagoon and the Wall Shrine were removed in the early 1970's, William Lightner's Grotto, as it is today, with four structures instead of the original five, remains a cohesive manmade environment centered around a small body of water with footpaths and beautiful plantings. For the existing structures the architectural design and underlying structural forms of reinforced concrete remain intact and strong according to our past and current conservators. Though it was a mistake to remove the original Lagoon and Wall Shrine (but unavoidable considering the Sisters of Mercy's financial situation), the addition of a new smaller pond (2002) in the footprint of the eastern extension of the old Lagoon has returned the crucial unifying element of water to the site. In reality the Eastern two thirds of the Grotto remain exactly as they always have been. Because most of the

United States Department of the Interior
National Park Service

National Register of Historic Places
Continuation Sheet

Section 7 Page 17 Property name Our Mother of Sorrows Grotto

County and State Linn County, Iowa

manmade structures were in this eastern area, there does not appear to be anything "missing". Removing the Wall Shrine and larger section of the Lagoon simply made the grotto green space seem to extend farther to the west. In addition, the large photo engraved interpretive plaque, placed on the site in 2001, shows it as it was originally and gives historical context to the remaining structures.

SETTING: The Grotto setting retains the same topography and tree cover as it has throughout its history. Warde Hall still stands a few yards above and to the north of the site. Vehicular drives built in the 1960's and separating the site from Warde Hall were removed in 2011. Cedar trees, paths, and walkways continue to link the Grotto district to the central campus. The neighborhood surrounding Mount Mercy remains nearly the same as well. The domestic dwellings in these blocks have been well taken care of and many families are in their second generation in these homes.

MATERIALS: Lightner's foundations, column, arches, walls, and roofs are as they were when built using reinforced concrete (Portland cement), local limestone, granite, Italian marble and other stone. Conservator inspections report the structures were solidly build by a man who was a highly trained, skilled builder in the German immigrant tradition but also familiar with the most advanced building techniques of the early twentieth century. Lightner's mosaics have also been well preserved. Since 1980 any surface embellishment stones or mosaic tiles that fall off the structures are saved and catalogued by University maintenance. In replacing lost materials, every effort is made to locate the same types of stones or to order mosaic from the same companies where the originals were purchased. All areas where restoration is required follow the Secretary of the Interior's Standards and Guidelines for Restoration.

WORKMANSHIP: William Lightner was a very skilled builder. He came from a family tradition of German builders who came to Cedar Rapids in the mid-19th century. Lightner was also skilled in stone masonry and in glass mosaic tile inlay. It is not known where he was trained but he was a friend of Father Paul Dobberstein from The Grotto of Redemption and gave building advice to Father Wenerus at The Holy Ghost Grotto in Dickeyville, Wisconsin. Indeed his skills in stone and mosaic inlay equal those of the best Italian and German immigrants of the 19th century, according to conservators Don Howlett and Lisa Stone. Lightner's stonework and glass tile mosaics are literally without space gaps. His engineering techniques, particularly in the Ten Commandments Monument are the subject of admiration to this day.

FEELING: The Grotto still serves as a quiet contemplative environment for individuals from the university community and the neighborhood, as well as for the many outside visitors to the site. It also continues to serve as a site for public reflection and gatherings. Group meditations by members of the local Buddhist Zen Center, area Catholic and Protestant denominations, as well as non-denominational

United States Department of the Interior
National Park Service

National Register of Historic Places
Continuation Sheet

Section 7 Page 18 Property name Our Mother of Sorrows Grotto

County and State Linn County, Iowa

gatherings for national and local holiday celebrations are held more and more frequently at the Grotto. In addition to Lightner's exotic structures and landscaping, the symbolic setting of the Grotto atop the highest point in Linn County among a grove of cedar trees and garden paths surrounding the New Pond helps maintain the feeling Lightner intended for this site.

Annual alumnae reunion surveys confirm that former students from decades past maintain strong feelings about the site and appreciate greatly the effort to preserve it as a place of meditation and serenity. Mound View Neighborhood Association members volunteer to do clean up at the grotto and regularly take walks and bring visitors to the site. They also come to our Annual May Day Celebration and contribute stories to our Grotto web site.

ASSOCIATION: Feedback from scholars as well as students, alumni and visitors confirm the continued association of the site with an atmosphere of public and private reflection in nature and with the history of the neighborhood, The Sisters of Mercy, and the University. The Grotto is easily recognized in spite of the loss of the Wall Shrine. The original Italian marble statue of the Virgin Mary (once part of the non-extant Wall Shrine) is now housed in a newer stone inlay canopy-structure, reminding the visitor of Lightner's original source of inspiration. Though given many names over time (*Lightner's Grotto Park, Our Lady of Sorrows Grotto, etc.*) the site continues to be referred to officially as a *The Grotto* by the University and the larger community.

The placement of an anodized aluminum interpretive plaque with historic images of the site enriches these associations. Restored park benches, walkways, gardens, stone paths, and the new pond have contributed to the sense of history it preserves. This is supported by the fact that we were able to raise matching funds from the community for all three of the major restoration grants named above.

FUTURE PLANS

The integrity of the Lightner's Our Mother of Sorrows Grotto has been threatened in the past (1970 removal of Wall Shrine and Lagoon, 1974 construction of parking lots near the site) and may be threatened again in the future. National Register listing will give the site the status needed to argue against future intrusions on or near the site for expansion of a small, land-locked university. The current University administration (since 2001) and its Development Department and Alumni fully support the Grotto's preservation. Things can change rapidly when there are changes in the University administration, however.

Future plans center around keeping the site as close as possible to the original in both physical condition and ambiance. Since the campaign to maintain and restore the site began in the 1980s, the

**United States Department of the Interior
National Park Service**

**National Register of Historic Places
Continuation Sheet**

Section 7 **Page** 19 **Property name** Our Mother of Sorrows Grotto

County and State Linn County, Iowa

site is regularly monitored for materials that have loosened or fallen off. Those materials are catalogued and saved in a special storage area reserved for the Grotto, until a professional conservator can restore that area. Following the completion of the NEA grant in 2014 the majority of structural restoration work will be done. Inspection and maintenance are ongoing, however. As part of our current NEA restoration grant, the University has now contracted with Technical Specialty Systems Inc., a certified local masonry restoration contractor (trained in the Department of the Interior's Standards and Guidelines for Restoration) for annual inspections, cleaning and maintenance of the site.

The small four-plex student apartment buildings constructed in 1974 along with Student Apartment Parking Lots S and N will be removed in a proposed 2014-2016 landscaping project. This will return green space to the area surrounding the existing structures and to the footprints of the original Lagoon and Wall Shrine.

Outreach to the community is essential in raising awareness and funding for future upkeep of the site. Future plans include creation of an audio walking tour of the site, a brochure on the history of the site and the life of William Lightner, and additions to our current Grotto web site to make it more interactive. We will encourage more student projects involving historical research of the site and the creation of related blogs, videos, etc. We plan to continue the outreach begun with our recent IAC and NEA grants by working with area schools, clubs and organizations to increase awareness of the site. The University's Art Club will continue to have an annual auction to raise money for annual restoration and cleaning. We also plan to continue our annual re-enactment of the May Day Celebration held at the Grotto site in the 1940s-60s. In addition, use of the site for public events and neighborhood gatherings will be announced and encouraged. Next year The Cedar Valley Rock and Mineral Club and the Questers of Northeast Iowa have annual gatherings scheduled on the site, in addition to the many University events scheduled there. We have begun to collaborate with the art programs of elementary and high schools in offering mosaic and photo/drawing workshops on the site.

United States Department of the Interior
National Park Service

National Register of Historic Places
Continuation Sheet

Section 8 Page 20 Property name Our Mother of Sorrows Grotto

County and State Linn County, Iowa

State 8. Narrative Statement of Significance

SUMMARY OF SIGNIFICANCE

Every now and then one man creates with his own hands and mind, something unusual, beautiful and expressive. Just such a construction is William Lightner's (Our Mother of Sorrows) grotto and shrine begun in 1929 and today donated to all who will see it. Mount Mercy has a great artist treasure.

Cedar Rapids Gazette, August 10, 1941

William Lightner's Our Mother of Sorrows Grotto is a visionary environment constructed by a master builder, craftsman, and artist. Lightner used his exceptional sense of design and sophisticated building techniques to create his personal vision in highly skilled stone inlay and Italian mosaic. Though Lightner's Grotto was originally built as a site for religious meditation, the nomination meets Criteria Consideration A as it is being nominated here under Criterion C as visionary art. Our Mother of Sorrows Grotto is also significant as a rare remaining example of Iowa visionary architecture and of the Midwestern grotto tradition of the early twentieth century. Lightner himself was a builder and self-trained artist responsible for designing other major buildings in Iowa including Lamoni's first bank, Warde Hall on the Mount Mercy campus, and St. Patrick's Church in Cedar Rapids. He was reportedly an Iowa representative on the National Standardization Committee during the Coolidge Administration and served as a representative on the Board of Directors for the Master Builders of Iowa ("W. H. Lightner..." *The Gazette*, 10/10/68, p. 3). However, for Lightner the multi-structure Our Mother of Sorrows Grotto site became his life's work and an obsession. He worked on the Grotto and its environs from 1929 to 1941 continuously until Archbishop Francis Beckman dedicated it in 1941. An archeological investigation was not a part of this report. Additional research may identify archeological evidence that could contribute to the overall historical significance of the property.

Criterion C is of primary significance in discussing Our Mother of Sorrows Grotto.

Criterion C: Lightner's Grotto embodies the distinctive characteristics of a type and a method of construction and represents the work of a master as well as possessing high artistic value.

The presence of monumental grottos had a profound impact on the artist-builders in this region and established a precedent for creative expression within the contexts of home and garden. The idea of grotto began to take root in the landscape of the collective imagination ...

(Stone and Zanzi, Sacred Spaces, p. 58)

William Lightner was one of a handful of Midwestern artists who continued a centuries-old European tradition of creating environments for contemplation in and of nature (not unlike the Ancient Roman *Tivoli Garden* in Italy). Making a significant contribution to this broader pattern in regional architectural history,

United States Department of the Interior
National Park Service

National Register of Historic Places
Continuation Sheet

Section 8 Page 21 Property name Our Mother of Sorrows Grotto

County and State Linn County, Iowa

Lightner made his site one of a few large grottos built to "transmit the prevailing spiritual beliefs in an atmosphere of supernatural beauty, a place for the spirit to be moved and stored." (Stone and Zanzi, *Sacred Spaces and Other Places*, p. 7)

Lightner's Our Mother of Sorrows Grotto was created in the tradition of such famed visionary art environments as Father Paul Dobberstein's Grotto of the Redemption in West Bend, Iowa (National Register, 2003) and Simon Rodia's Watts Towers in Los Angeles. It is one of a few major grotto sites unique to Iowa and Wisconsin, including both Dobberstein's Grotto and Father Wernerus' Holy Ghost Grotto in Dickeyville, Wisconsin. In a recent journal article, School of The Art Institute of Chicago historian and noted grotto conservationist, Lisa Stone, states:

The upper Midwest region of the United States is rife with grotto type environments that are not called follies (the British term for such structures) –but could be so, if by folly we mean things architectural with a landscape, created to provide an unanticipated place for personal (or collective) reflection and enjoyment: to express a sense of historical time, and to enliven and sanctify a place by its presence. The phenomenon of grottos and sculptural environments in the Upper Midwest is unique in at least two ways: the large number of grottoes and folly-like sites that are linked to a common source (Father Dobbersteins's Grotto of Redemption in West Bend, Iowa) and concentrated in one region, and the remarkable history of preservation of many of the sites.

(Stone and Zanzi, *The Follies Journal*: No. 11, p. 1)

According to Dr. Susannah Koerber, Senior Vice President of Collections for the Indiana State Museum, grotto building in the Midwest peaked during the 1920s and 1930s, the same period during which Lightner was building. His work shares many similarities in technique, intent, and subject with the more widely known grottos built in and around Iowa (including, as mentioned above, both Dobberstein's and Wernerus' grottos). Lightner consulted other grotto builders across the region, learning specific techniques, adapting designs, and collecting a wide variety of stones and other materials from regional sources and beyond.

Like these few large-scale grotto builders, he also relates to larger trends of park design and monumental sculpture that were being adapted to fit the Midwestern environment. The conception of a group of shrines and other structures around a public space is a key aspect of the most outstanding grotto designs in the region.

(Koerber, November 2, 2013 letter)

Who built these grottos? Dr. Koerber notes that for the most part Midwestern grottos of this period were the work of German Catholic priests or clergy. Most were first generation Americans or had been sent to a seminary in the Midwest directly from Germany or elsewhere in Southern Europe. In fact, both Dobberstein and Wernerus attended the seminary in Milwaukee, where a grotto shrine to Fatima, an admired saint in

United States Department of the Interior
National Park Service

National Register of Historic Places
Continuation Sheet

Section 8 Page 22 Property name Our Mother of Sorrows Grotto

County and State Linn County, Iowa

Southern Europe in the early 20th century, was centrally located on the campus. This shrine was, in turn, influenced by the famous Fatima Shrine built in the late nineteenth century. Almost all of these grottos and shrines were built as thanks to a particular saint or to the Holy Virgin for answering desperate prayers to be saved from a life-threatening situation. The visionaries among these grotto builders were essentially artists who taught themselves the skills needed to express their visions in stone. It is worth noting that William Lightner was the only Iowa large-scale grotto builder who was not a priest or clergyman in the Catholic Church.

Quoted here from *the National Register Application* (2003) for Dobberstein's *Grotto of Redemption* (Palo Alto County, Iowa), Stone and Zanzi discuss how the definition of "grotto" has developed in the Upper Midwest and nationally:

...the social and spiritual consciousness regarding the relationship of man to nature, and the status of nature itself, that Father Dobberstein and many of his contemporaries embraced corresponds with the historical and conceptual development of the grotto. In its ancient and classical forms the grotto was a form of nature incarnate, a place where spiritual and oracular experiences were inseparable from the form, context, and essence of its natural surroundings. The artificial grotto, one step removed from its origin, could imitate and elaborate on nature, while the potential for departing from it altogether was limitless. The Midwestern Grotto is most often an amalgamation of geological treasures, architectural styles and amorphous forms.

In "Concrete Visions: The Midwestern Grotto Environment," *Image File* ('90), Stone states that the re-introduction in the early 20th century of Portland cement technology as well as the availability of bagged concrete profoundly affected the landscape of the Midwest in two ways: the development of the grain elevator and of the Midwestern grotto environment (built as a result of a growing popular interest in the grotto form). Because Lightner was a trained builder, contractor, and self-taught artist, his knowledge of concrete and its new applications (including reinforced concrete) were extensive compared to that of Father Paul Dobberstein in West Bend or Father Wernerus in Dickeyville. In her doctoral dissertation comparing Midwestern grottos to Southern Protestant vernacular architecture, Dr. Susannah Koerber also discusses Lightner's important connections to Dobberstein and Wernerus. During her research she found letters from Wernerus to Lightner asking questions on building techniques and concrete recipes.

In her November, 2013 letter to the State Historical Society of Iowa supporting National Register status for Lightner's Grotto, Lisa Stone goes on to say:

**United States Department of the Interior
National Park Service**

**National Register of Historic Places
Continuation Sheet**

Section 8 Page 23 Property name Our Mother of Sorrows Grotto

County and State Linn County, Iowa

The Mother of Sorrows Grotto is an exceptional expression of an important regional tradition in Iowa, about which awareness is growing as more examples are discovered. It's the second most extensive, largely intact grotto environment in Iowa.

(Stone, November 3, 2013 letter)

William H. Lightner himself was an eccentric in some ways but also very much a community man who contributed greatly to the landscape of Eastern Iowa. He was born in Cedar Rapids on April 1, 1885 and died there on October 10, 1968 at age 82. He is buried in Mt. Calvary Cemetery in Cedar Rapids.

A professional wrestler known throughout the Midwest in his youth, Lightner went on to become a partner in his family's construction business and then to form his own contracting business in 1907. He served on the Board of Directors of the Master Builders of Iowa and on several riverfront development and zoning commissions. After retiring in 1942 he continued to work and to donate his design skills and his money to community projects.

Local historian Ortha Harstad (now deceased), whose father John Berger had worked with Lightner on the Grotto and eventually bought his construction company, completed a written overview of Lightner's accomplishments in 2001. She noted that Lightner was known throughout the city of Cedar Rapids as a generous man, often donating his building services and/or money to both Catholic and civic projects.

Lightner, like all great artistic creators, was also a recognized master of his craft. He learned his masonry and building skills from his second-generation immigrant German father and uncles. His skilled mosaic and stone inlay work were done without grout and almost without gap. He was evidently self-taught in these skills but had opportunity to see some of the finest of examples at cathedrals in Chicago during his wrestling career.

In 2002 Dennis Jennings, an alumnus and artist, did extensive interviews with the Sisters of Mercy who remembered Lightner and his work. Jennings also unearthed archival material from Lightner's only remaining local relatives. Jennings's resulting film, *William Lightner: Visionary*, is in the University's Archives and can be seen on the University web site Grotto pages. This film can also be accessed on *Vimeo* along with three other films about the Grotto made between 2001-2005 (produced by Kansas City Public Television, Mount Mercy University and The Cedar Rapids Community School System respectively). Jennings research did much to help unravel Lightner's inspirations as an artist and his motivations in building the Our Mother of Sorrows Grotto.

United States Department of the Interior
National Park Service

National Register of Historic Places
Continuation Sheet

Section 8 Page 24 Property name Our Mother of Sorrows Grotto

County and State Linn County, Iowa

Most significant to the Grotto, in 1907 Lightner converted to Catholicism after meeting and marrying a local Irish Catholic woman, Catherine Devlin. William and Catherine Lightner made their home at 1700 C Avenue NW in Cedar Rapids. The structure is still standing but with a new street number. After his marriage, Lightner's faith became more and more fervent. His conversion to Catholicism is also what precipitated a split in the family contracting business. The Lightner family, of German and Bohemian Protestant heritage, was not pleased with his conversion. As a result he split from the family business becoming Lightner Brothers, General Contractors, originally located in the Security Building at 205 South Second Avenue West and later moved to 96 Second Avenue West at the west end of the Second Avenue Bridge, all in Cedar Rapids. His two brothers formed Lightner and Lightner, General Contractors, with an office at 1958 Grande Avenue.

Lightner's faith became a driving force in his business as well as his personal life. After joining St. Patrick's Church in 1915, many of his projects involved the construction of Catholic schools and churches. Quite often he donated his work as both designer and builder. As noted above, he lent considerable cash to the Catholic Church in Cedar Rapids to help accomplish their building projects.

Lightner's construction company had just completed Warde Hall on the Mount Mercy Academy campus when he began the Grotto complex. During the Warde Hall project Lightner had become close friends with the Sisters of Mercy who administered the Mount Mercy Academy. In addition to lending them money to buy more property and to build Warde Hall, he asked to create a monument to honor the Sisters of Mercy and to commemorate his conversion. The Sisters suggested he build a Grotto to the Virgin Mary (later this became Our Mother of Sorrows) and thus began his twelve-year artistic odyssey. The Sisters of Mercy gave him a long-term lease on twenty acres of the Mount Farm estate. In return he lent them more money to buy more land and he built and paid for all the structures in the Grotto.

Our Mother of Sorrows Grotto, then, became Lightner's life's work and his artistic masterpiece. For him the site had meaning on several levels and like many great artists, he had a muse. Lightner's beloved wife Catherine was the ultimate inspiration for his grotto. His love for Catherine, as well as his consequent religious conversion, stirred him emotionally to create his artistic *tour de force*. From start to finish Lightner initiated and accomplished every step with only minimal assistance. He approached the Sisters of Mercy, then gathered, planned, prepared and paid for everything involved with his Grotto. Lightner created each structure of the Grotto stone by stone. This unique work of personal artistic vision is unlike any other structure Lightner designed in his lifetime.

The Grotto not only demonstrates Lightner's artistic vision, it also best represents his civic and charitable projects. Lightner designed and built many other significant structures in Iowa as mentioned above. Newspaper articles documenting his other architectural designs and mosaic and stone inlay work are included in the University Busse Library Archives. The November 23, 1951 *Cedar Rapids Gazette* pictures

United States Department of the Interior
National Park Service

National Register of Historic Places
Continuation Sheet

Section 8 Page 25 Property name Our Mother of Sorrows Grotto
County and State Linn County, Iowa

and discusses the new magnificent main altar of St. Patrick's Church. Though Lightner had retired by this time, he put a great deal of time and effort into the rebuilding project. He reportedly imported more than 120,000 pounds marble and statuary from Italy for the job as well as designing a stained glass dome, hammered brass railings, and an onyx crucifix. Evidently, Lightner visited many churches throughout the country for new ideas. This is the only project, other than his Grotto, where Lightner had significant artistic license. Unfortunately, the great Cedar Rapids Flood of 2008 destroyed the interior of St. Patrick's Church.

SITE HISTORY

The Sisters of Mercy, who had already opened a hospital, a school for girls and a nursing school in Cedar Rapids, Iowa in the late nineteenth century, purchased Mound Farm (then outside the city limits of Cedar Rapids) in 1906, a move that would lay the groundwork for Mount Mercy Academy and later a Junior College, which was opened by the Sisters on September 9, 1928. As other buildings were added to the campus, the old Greene Mansion, home to the Sacred Heart Convent that predated Mount Mercy Academy, was torn down. An early settler, Judge George Greene, who himself has an important place in Cedar Rapids history, originally owned Mound Farm. Mount Mercy went on to become a four-year liberal arts college in 1960, co-ed in 1969, and a University in 2010. Mount Mercy University is now a Catholic university founded by the Sisters of Mercy and operated by an independent, non-denominational board of trustees. It is open to women and men of all beliefs in pursuit of baccalaureate and graduate education. Though the Grotto site is owned by the University, it is open to the public and has long been used as a neighborhood park.

What began in 1929, then, as a single structure in homage to Lightner's conversion to Catholicism became a twelve-year multi-structure obsession. Eventually The Sisters of Mercy, for whom he was building the grotto shrine, had to take legal action to convince him to stop building. There had been a change in administration at the convent and a subsequent request to access more of the land (originally given to Lightner) so it could be mortgaged for cash to build new buildings. They had originally contracted to give Lightner some 20 acres for the Grotto but now wanted to reduce that to 1.5 acres. He had lent the Sisters a great deal of money in the past and used his own funds to build the Grotto so he refused their request. When the Sisters of Mercy sued Lightner to stop building on the Grotto site, he lost the suit in the lower court. After several appeals by Lightner, going as far as the Iowa Supreme Court, the final decision was in favor of The Sisters of Mercy and declared the original contract null and void. Lightner and the Sisters eventually settled amicably, however, and Lightner went on to finish the Grotto in an agreed upon three years from the time of the settlement in 1938. Lightner then stopped building and his *vision in stone* was finally dedicated in 1941. Lightner remained on good terms with the Sisters of Mercy, particularly the group who originally contracted him to build the Grotto. He continued to lend them money as well. Had Lightner not been stopped in his vision for the Grotto, however, it would have gone on to become much larger. As it was, it was the second largest Grotto site in Iowa.

United States Department of the Interior
National Park Service

National Register of Historic Places
Continuation Sheet

Section 8 Page 26 Property name Our Mother of Sorrows Grotto

County and State Linn County, Iowa

From its beginning the Grotto acreage was a haven for reflection and meditation as well as a favorite location for college and community ceremonies. It became a neighborhood gathering place and a picturesque setting for weddings and pageants, including the annual college (then all-women) May Day Festival and May Crowning. Stories collected from surviving Sisters of Mercy in 2002 talk about Sunday afternoons when they would sell popcorn for a nickel to all the visitors. The Grotto could draw as many as seven hundred visitors in one day during the 1946 Iowa State Centennial Celebrations when seven scenes from the state's history were reenacted as tableaux vivant on the site. A 1967 *Time Magazine* issue featured an image of one of these tableau images in an article on Midwestern higher education. Two coeds dressed as pioneers row a canoe in the Lagoon with the Grotto Bridge in the background.

There have been changes over the years, but the University now maintains the Grotto structures and the immediate landscape setting is beautifully designed with gardens and footpaths. As discussed in the *Narrative Description*, a restoration project under the direction of conservator Anton Rajer in 2001-02 resulted in some structural and cosmetic surface restoration of the Grotto elements and in re-establishing the lagoon as a smaller, shallower pond. The reintroduction of the water element did much to restore the original character of the site. A 2001 aluminum didactic plaque was installed on the stairway leading down to the pond, providing viewers with information and vintage photographs. In 2011-12 the new University Center was built as a front attachment to McAuley Hall facing a newly designed central grass quadrangle. All vehicular roads that accessed central campus are removed so that only foot traffic is allowed. A special walkway, The Walk of Mercy, was built connecting the Grotto complex to the new University Center to the grass Quad at the top of the hill. This returned the Grotto district to a major central focal point of the campus once again.

For more than eighty-five years, the Our Mother of Sorrows Grotto complex has anchored Mount Mercy University as a treasured and unique feature of the campus. Dr. Susannah Koerber notes in her recent letter of support:

The extant grotto structures demonstrate Lightner's plan to create a space for meditative and recreational use that was also the focal point for the campus. Located as a visual centerpiece for the developing college, it unified the campus, tying together Warde Hall (1924), for which Lightner was the designer and contractor, and the convent and motherhouse of the Sisters of Mercy. Lightner conceived the grotto park as he was building Warde Hall, and by 1930 the area was already a destination, referred to as "The Pool in the Glen," although the structures would not be completed and dedicated until 1941. The grotto park provided a gathering space for informal and formal events, from casual strolls to pageants, patriotic demonstrations, and graduations.

Today the grotto district continues to serve that function, with the University Center (attached to McAuley Hall) serving as the social and physical pole once represented by the convent. One of Lightner's arches anchors the footpath leading from Warde and the other from McAuley/University

**United States Department of the Interior
National Park Service**

**National Register of Historic Places
Continuation Sheet**

Section 8 Page 27 Property name Our Mother of Sorrows Grotto

County and State Linn County, Iowa

Center into the quad space. The university has recognized the power of Lightner's original plan and the importance of the grotto structures by restricting the area to foot traffic and restoring the pond, reestablishing aesthetic unity among the structures and allowing Lightner's bridge and the island with the 10 Commandments monument to function as they once did.

(Dr. Susannah Koerber, support letter, 11-2-13)

Summary of Significance: Conclusion

William Lightner's Our Mother of Sorrows Grotto District is eligible for the National Register for several reasons. First of all, it is a rare remaining example of the large-scale Grotto complex in Iowa. Lightner's Grotto is also a primary and an outstanding example of the early and mid-twentieth century Grotto phenomenon, which is unique to the upper Midwest. In this regard, Lightner's work demonstrates the influence of Father Paul Dobberstein's Grotto of Redemption on all the Iowa grotto builders. This influence cannot be understated. Few structures remain to support this prevailing theory of grotto origins in this geographical area.

Of all the structures Lightner designed as a contractor, this site is our best and only example of his work as a visionary artist and a master craftsman. Though Father Dobberstein's Grotto of Redemption no doubt inspired Lightner, he was able to translate his experience of it into his own masterful vision. With minimal assistance he worked on his creation daily for twelve years and evidently would have continued indefinitely had he not been stopped.

Recognition of this unique achievement continues to grow on regional, national, and even international levels. In recent years Lightner's Grotto has been awarded one state (IAC) supported and two major national (Smithsonian and NEA) restoration grants. It has also been included on the Linn County Historic Preservation Guide to Historic Sites and has been the subject of several internationally published scholarly articles and three local and national professionally produced films. In the 1930s through the 1950s, the heyday of Grotto creations, Lightner's Grotto attracted hundreds of visitors every weekend. To this day it continues to attract tourists and historians, as well as a variety of community and school groups as diverse as the Iowa Sequesters, the local Girl Scouts, and the Linn County Geological Society. The University's Grotto Archives are filled with letters from visitors who happened upon the site and took wonder in its artistic achievement. As one serendipitous visitor states, "...this is one of the best kept secrets in Iowa." This kind of interest is unique. There are many handmade, individually conceived roadside attractions and artworks in Iowa, but few have received this quality of interest from both the public and academia.

**United States Department of the Interior
National Park Service**

**National Register of Historic Places
Continuation Sheet**

Section 8 Page 28 Property name Our Mother of Sorrows Grotto

County and State Linn County, Iowa

Nationally recognized visionary architecture and grotto historians Dr. Susannah Koerber and Lisa Stone have written letters of support for this nomination. Lisa Stone states in her support letter of November 3, 2013:

The Mother of Sorrows Grotto complex was a labor of love and an expression of his devotionas well as a major and enduring contribution to the identity and life of Mount Mercy University, to Iowa, and the nation.

“Place” is often associated with memory. Our 2002 request for stories about the Grotto from retired Sisters of Mercy, alumni and neighbors made clear that images of William Lightner’s Our Mother of Sorrows Grotto remain clear in their memories long after others have faded. The existing structures of Lightner’s Grotto are almost entirely authentic and serve as a significant link to the past for those who visit. In reference to William Lightner’s Our Mother of Sorrows Grotto, Dr. Susannah Kroeber states:

The Lightner grotto district has clear connections to the Midwestern grotto tradition but a strong individual style and relationship to its setting that make it an outstanding example and one whose preservation should be ensured... In its artistry, Lightner’s work is among the finest visionary architectural environments in the United States and has a rich history as part of Mount Mercy University and the surrounding community.

(Kroeber, letter of support, November 2, 2013)

William Lightner’s Our Mother of Sorrows Grotto comes from a deep personal vision and a need to communicate in one’s own visual language. This language came within the unique architectural genre of early twentieth century Midwestern grottos. In spite of Lightner’s many contributions to Eastern Iowa architecture, this Grotto is the only example and all that remains of his exceptional artistic vision. Perhaps the words of a 1941 *Cedar Rapids Gazette* reporter, quoted in the introduction for this section, still say it best:

*Every now and then one man creates with his own hands and mind,
something unusual, beautiful and expressive.*

(*Cedar Rapids Gazette*, August 10, 1941)

United States Department of the Interior
National Park Service

National Register of Historic Places
Continuation Sheet

Section 9 page 29 Property name Our Mother of Sorrows Grotto Historic District

County and State Linn County, Iowa

9. Major Bibliographical Sources

American Stories, exhibition catalog, John Michael Kohler Arts Center, Sheboygan, Wisconsin, 1999

Beardsley, John. *Gardens of Revelation*. New York, New York. Abbeville Press, 1995

Cassel, Andrew. "The Dream that Keeps on Growing," *The Philadelphia Inquirer*, May 10, 1990. p. 3-A

Cubbs, Joanne. "Spontaneous: A brief critical history of "outsider art" environments," *Public Art Review*, Minneapolis, MN Summer/Fall 1992, pa 10 -14

Grotto Stories (from interviews by Dennis Jennings of The Sisters of Mercy in Cedar Rapids, Iowa and from letters solicited from MMU alumnae and Mound Farm Neighborhood in Cedar Rapids, Spring - Fall, 2002) booklet published by Mount Mercy University, May 2012. (Booklet available through Mount Mercy University, videos and transcriptions of video interviews of sisters of Mercy from 2001 by Dennis Jennings and 2000 by Jane Gilmor are in the Grotto Archives, Special Collections, Busse Library, Mount Mercy University, Cedar Rapids, Iowa)

Hall, Michael D. and Eugene W. Metcalf, Jr., Eds. *The Artist Outsider: Creativity and the Boundaries of Culture*. Washington and London: Smithsonian Institution Press, 1994

Historical Sites of Linn County, brochure by Linn County Historic Preservation Commission, Cedar Rapids, Iowa 2004. (Two copies housed in Grotto Archives, Mount Mercy University Archives, Busse Library, Cedar Rapids,

Hutchinson, Duane. *Grotto Father*, Foundation Books, Lincoln, NE.1989

Jennings, Dennis and Matthew Butler *William Lightner: Visionary*, 20-minute documentary film on the life of William Lightner (following a year of research and interviews with family and The Sisters of Mercy by Dennis Jennings), 2002. (Scans of all documents used in film and research are located in the Mount Mercy University Archives: Grotto Archives, Busse Library and <https://vimeo.com/20473534>)

KCPTV, Kansas City Public Television, "Back to the Breadbasket," *Rare Visions and Roadside Revelations*. Public Television 19, Inc., 2005. (Can be ordered online through KCPTV and there are two copies in the MMU archives, Busse Library)

Koerber, Susannah. "A Particular Time and Place: Visionary Grassroots Architecture in the Midwest." Lecture at Mount Mercy College, November 1, 2001. (Transcript available through Susannah Koerber, State of Indiana Museum, Indianapolis, In.)

**United States Department of the Interior
National Park Service**

**National Register of Historic Places
Continuation Sheet**

Section 9 **page** 30 **Property name** Our Mother of Sorrows Grotto Historic District

County and State Linn County, Iowa

Koerber, Susannah. Letter of support for Our Mother of Sorrows Grotto Application to the National Register of Historic Places, November 2, 2013.

Koerber, Susannah. "Self-Made Worlds Worth Keeping." *Art Papers*, Vo. 22, Atlanta, Jan.-Feb., 1998, pp. 18-22

McFarland, Pat. "Dedication Tuesday for St. Patrick's Church," *Cedar Rapids Gazette*, Cedar Rapids, Iowa Nov. 23, 1951. P. 8

Maizels, John. *Fantasy World*, Cologne, Germany. Taschen, 1999

Manley, Roger. *Signs and Wonders: Outsider Art Inside North Carolina* (Raleigh: North Carolina Museum of Art, 1987

National Register of Historic Places Registration Form for The Grotto of Redemption, Palo Alto County, Iowa, United States Department of The Interior, National Park Service, OMB NO. 1024-018, November 17, 2003

Niles, Susan A. *Dickeyville Grotto: The Vision of Father Mathias Wernerus*, University Press of Mississippi, 1997

Ohm, Steven, Ed. *Passing Time and Traditions Contemporary Iowa Folk Artists*. Ames: The Iowa State University Press, 1984

Preservation Services, Inc., *Preservation Plan Our Mother of Sorrows Grotto*, Mount Mercy College, Cedar Rapids, Iowa July 2010. (Grotto Archives, Mount Mercy University Archives, Busse Library, Cedar Rapids, Iowa)

Rajer, Anton. *The History and Conservation of Our Mother of Sorrows Grotto, Mount Mercy, College, Cedar Rapids, Iowa*, (Smithsonian Institution, American Heritage Save Outdoor Sculpture! (S.O.S.!) Grant, 2001-2 Restoration Project Final Report) Fine Arts Conservation Services, Madison, Wisconsin, 2002. (Grotto Archives, Mount Mercy University Archives, Busse Library, Cedar Rapids, Iowa)

Rajer, Anton. *Preserving Folk Art Environments*, AR 290, notes taken by Jane Gilmor from three-credit course offered at Mount Mercy College, July 8–August 9, 2002. (Grotto Archives, Mount Mercy University Archives, Busse Library, Cedar Rapids, Iowa)

"Raw News: Lightner Grotto," *Raw Vision, International Journal of International Outsider Art*. Fall 2001, p. 15

United States Department of the Interior
National Park Service

National Register of Historic Places
Continuation Sheet

Section 9 page 31 Property name Our Mother of Sorrows Grotto Historic District

County and State Linn County, Iowa

Roth, Sister Mary Augustine, R.S.M. *Courage and Change, Mount Mercy College: The First Fifty Years*. Stamats Publishing, Cedar Rapids, Iowa, 1980, pp.48-49, 172-176. (Mount Mercy University Special Collections, Busse Library, Cedar Rapids, Iowa)

Roth, Sister Mary Augustine, R.S.M. *Written in His Hands: The Sisters of Mercy of Cedar Rapids, Iowa 1875-1975*, Laurence Press Company, Cedar Rapids, 1976. (Mount Mercy University Archives, Busse Library, Cedar Rapids, Iowa)

Scenic Sculpture: Preserving Folk Art Treasures (Grotto Restoration at Mt. Mercy), Cedar Rapids Public School System, 14-minute video, July 2002. (Grotto Archives, Mount Mercy University Archives, Busse Library, Cedar Rapids, Iowa)

Stone, Lisa and Jim Zanzi, "Grotto Follies in the Heartland." *The Follies Journal*: No. 11, *Grottoes and other Follies*, Winter 201, United Kingdom

Stone, Lisa. "Grottos in the Heartland," The Grotto Lecture Series. Mount Mercy University, November 3, 2011. (Notes available through Lisa Stone, conservator, The School of the Art Institute of Chicago, Roger Brown Study Center)

Stone, Lisa.. Letter of support for Our Mother of Sorrows Grotto Application to the National Register of Historic Places, November 2, 2013.

Stone, Lisa, and Zanzi, Jim. , Jim. "Miracle in Stone," *The Iowan* 44:3 (Spring 1996), pp. 24-31

Stone, Lisa, and Zanzi, Jim. *Sacred Spaces and Other Places A Guide to the Grottos and Sculptural Environments of the Upper Midwest*, Chicago: The School of the Art Institute of Chicago Press, 1993

Supreme Court of Iowa. *Sisters of Mercy of Cedar Rapids v. Lightner* No. 43528, June 15, 1937 (<http://web2.westlaw.com/resul/documentsext.aspx>)

"W.H. Lightner Dies, Retired Contractor." *The Gazette* (Cedar Rapids, IA), October 10, 1968, p. 3 <http://iagenweb.org/linn/obits/lewis.htm>

Zentz, Jeremiah. *William Lightner's Our Mother of Sorrows Grotto*, 15-minute documentary film including interviews with Sisters of Mercy alive when Lightner built the Grotto. (Grotto Archives, Mount Mercy University Archives, Busse Library Special Collections, Cedar Rapids, Iowa)

United States Department of the Interior
National Park Service

National Register of Historic Places
Continuation Sheet

Section 9 **page** 32 **Property name** Our Mother of Sorrows Grotto Historic District

County and State Linn County, Iowa

Web Resources:

Mount Mercy University. (2010, January 22). William Lightner's Our Mother of Sorrows Grotto. Retrieved July 15, 2013 from <http://www.mtmercy.edu/grotto>

Mount Mercy University Library. (2010, March 3). Grotto Photographs from Busse Library Archives. Retrieved July 15, 2013 from <http://cdm16329.contentdm.oclc.org/cdm/search/searchterm/grotto>

SPACES, Saving and Preserving Arts and Cultural Environments, a non-profit arts service and archive, Los Angeles, California, www.spacesarchives.org

Jeremiah Zentz (2002, March 1). *Mount Mercy University's Our Lady of Sorrows Grotto*. Retrieved July 15, 2013 from <https://vimeo.com/62261024>

Jennings, D. & Butler, M. (2004, July 12). *Films on Lightner: William Lightner Visionary*. Retrieved July 15, 2013 from <http://www.mtmercy.edu/news-events/video/2011/03/09/films-lightner%E2%80%99s-work>

II. Location of other data: Mount Mercy University: Busse Library Archives, Special Collections

United States Department of the Interior
National Park Service

National Register of Historic Places
Continuation Sheet

Section 10 page 33 Property name Our Mother of Sorrows Grotto Historic District

County and State Linn County, Iowa

10. Geographical Data Note: North is always top of page

Verbal Boundary Description

Please see Figure # 1

From a starting point of the (central) Grotto Bridge, this site extends **north** approximately 117 feet to the sidewalk along the southern edge of Warde Drive on the campus, **west** 140 feet past the Warde Arch to the eastern side of the entry to Apartment Parking Lot N (entry is from Warde Drive), **east** 205 feet to immediately beyond the McAuley Arch, and **south** six feet from the bridge and then following the southern edge of the green space surrounding the grotto. The southern boundaries are described by the edge of the green space that ends at the northern boundaries of Parking lots N and S and the driveway between them. The site is bordered on the northeast by a sidewalk with iron railing and on the southeast by a sidewalk that ends at the southeastern corner of Apartment Parking Lot S. The site is bordered on the southwest by the northern boundaries of Apartment Parking Lot N and the southern edge of the green space surrounding the grotto park area. As seen in **Figure # 1**, a solid dark line denotes these exterior boundaries of the property nominated.

Boundary Justification

The nominated property boundary has been drawn to include the contributing resources historically associated with William Lightner's Our Mother of Sorrows Grotto and reflects comments from the National Register staff issued May 15, 2014.

**United States Department of the Interior
National Park Service**

**National Register of Historic Places
Continuation Sheet**

Section _____ **Photo** _____ **page** 34 **Property name** Our Mother of Sorrows Grotto Historic District
County and State Linn County, Iowa

PHOTO SECTION: All included photographs are available in the **Mount Mercy University Busse Library, Special Collections: Grotto Archives**. All Photographs are printed with archival Epson Ultra Chrome ink on K3 Epson Ultra Premium Paper as required. Professor Jane Gilmor, Mount Mercy University, and Professor David Van Allen took all contemporary images of the site. See Figure #2 for guide to location of camera for each photograph.

PHOTO LOG

Photo #1 Our Mother of Sorrows Grotto, Linn, Iowa, Van Allen, 2013, overview of New Pond, Ten Commandments, Bridge and New Canopy structure over Virgin Mary statue, camera facing NW, # 0001

Photo # 2 Our Mother of Sorrows Grotto, Linn, Iowa, Van Allen, 2013, panoramic view of Grotto site with New Pond, Bridge, Ten Commandments, and new Canopy Structure with Virgin Mary statue, camera facing NE, #0002

Photo # 3 Our Mother of Sorrows Grotto, Linn, Iowa, Gilmor, c. 2011, aerial view Ten Commandments structure (before Globe was restored), camera facing NE, # 0003

Photo #4 Our Mother of Sorrows Grotto, Linn, Iowa, Gilmor, 2013, Ten Commandments structure in foreground, Bridge over new pond and Warde Hall (non-contributing) in background, camera facing NW, #0004

Photo #5 Our Mother of Sorrows Grotto, Linn, Iowa, Gilmor, 2013, Ten Commandments as seen through Grotto Bridge, camera facing SE #0005

Photo #6 Our Mother of Sorrows Grotto, Linn, Iowa, Gilmor, 2013, Ten Commandments newly installed restored globe of smalti mosaic inlay, camera facing NE #0006

Photo #7 Our Mother of Sorrows Grotto, Linn, Iowa, Gilmor, 2013, Ten Commandments detail of Italian smalti mosaic, camera facing SE, #0007

Photo #8 Our Mother of Sorrows Grotto, Linn County, Iowa, Gilmor, 2013, Grotto Bridge, detail of tops of two columns, camera facing E, #0008

Photo #9 Our Mother of Sorrows Grotto, Linn County, Iowa, Gilmor, 2013, detail of Warde Arch rock inlay interior of arch on East side, camera facing E, #0009

Photo #10 Our Mother of Sorrows Grotto, Linn, Iowa, Gilmor, 2012, Warde Arch (with Student Apartment four-plex and parking Lot "N" in background, camera facing SE #0010

United States Department of the Interior
National Park Service

National Register of Historic Places
Continuation Sheet

Section _____ **Photo** page 35 **Property name** Our Mother of Sorrows Grotto Historic District

County and State Linn County, Iowa

Photo # 11 Our Mother of Sorrows Grotto, Linn, Iowa, Gilmor, 2012, Grotto Bridge with Warde Hall in background (non-contributing), camera facing NW, #0011

Photo # 12 Our Mother of Sorrows Grotto, Linn, Iowa, Gilmor, 2012, Grotto Bridge, with new Canopy structure housing Virgin Mary in left background and Ten Commandments in right background, pond and gardens, camera facing SE, #0012

Photo # 13 Our Mother of Sorrows Grotto, Linn, Iowa, Gilmor, 2012, Detail of 12 x 12" mosaic section under Eastern Bridge arch, camera facing sky, #0013

Photo # 14 Our Mother of Sorrows Grotto, Linn, Iowa, Gilmor, 2012, Grotto Bridge following walkway, camera facing NE, #0014

Photo # 15 Our Mother of Sorrows Grotto, Linn, Iowa, Gilmor, 2012, Grotto Bridge, detail on top urn with flowers and mosaic inlay, camera facing SW, #0015

Photo # 16 Our Mother of Sorrows Grotto, Linn, Iowa, Gilmor, 2012, Grotto Bridge, view of top urn with flowers with rock and mosaic inlay, camera facing SW, #0020

Photo # 17 Our Mother of Sorrows Grotto, Linn, Iowa, Gilmor, 2012, Detail of Warde Arch looking toward sky from under arch, camera facing up, #0017

Photo # 18 Our Mother of Sorrows Grotto, Linn, Iowa, Gilmor, 2012, Warde Arch with student apartments behind (non-contributing) camera facing SW, #0018

Photo # 19 Our Mother of Sorrows Grotto, Linn, Iowa, Gilmor, 2012, Warde Arch detail of rock inlay, "Blessed Art Thou Among Women", camera facing N, #0019

Photo # 20 Our Mother of Sorrows Grotto, Linn, Iowa, Gilmor, 2012, McAuley Arch detail of finial rock and tile inlay, camera facing SE, #0020

Photo # 21 Our Mother of Sorrows Grotto, Linn, Iowa, Gilmor, 2012, McAuley Arch looking toward pond, camera facing W, #0021

Photo # 22 Our Mother of Sorrows Grotto, Linn, Iowa, Gilmor, 2012, McAuley Arch looking toward sky, camera facing SW, #0022

Photo # 23 Our Mother of Sorrows Grotto, Linn, Iowa, Gilmor, 2012, McAuley Arch looking toward McAuley Hall, camera facing SE, #0023

**United States Department of the Interior
National Park Service**

**National Register of Historic Places
Continuation Sheet**

Section _____ **Photo** page 36 **Property name** Our Mother of Sorrows Grotto Historic District

County and State Linn County, Iowa

Photo # 24 Our Mother of Sorrows Grotto, Linn, Iowa, Gilmor, 2013, overview walkways and gardens, New Pond, Ten Commandments, and new Canopy Shrine stone inlay structure (b. 2004, non-contributing) housing Virgin Mary Italian Marble statue far left behind pond, (c.1940's, contributing), camera facing SE, #0024

Photo # 25 Our Mother of Sorrows Grotto, Linn, Iowa, Gilmor, 2012, Canopy Shrine Structure (non-contributing) housing Virgin Mary Italian marble statue (contributing), benches walkway and New Pond in foreground, camera facing NW, #002,

Photo # 26 Our Mother of Sorrows Grotto, Linn, Iowa, Gilmor, 2013, Canopy Shrine Structure (non-contributing) housing Virgin Mary Italian marble statue (contributing), camera facing E, #0026

Photo # 27 Our Mother of Sorrows Grotto, Linn, Iowa, Gilmor, 2013, detail of Virgin Mary Italian marble statue(c, 1940, contributing), camera facing NE, #0027

Photo # 28 Our Mother of Sorrows Grotto, Linn, Iowa, Gilmor, 2012, Interpretive Plaque (2001) with historic images and text, camera facing S, #0028

Photo # 29 Our Mother of Sorrows Grotto, Linn, Iowa, Gilmor, 2012, view of Grotto May Day Celebration re-enactment 2012, camera facing SE, #0029

Photo # 30 Our Mother of Sorrows Grotto, Linn, Iowa, Gilmor, 2012, view of Grotto May Day Celebration Scarf Dance re-enactment 2012, camera facing SE, #0030

United States Department of the Interior
National Park Service

National Register of Historic Places
Continuation Sheet

Section Imbedded page 37 Property name Our Mother of Sorrows Grotto Historic District
County and State Linn County, Iowa

IMBEDDED IMAGES LOG:

All included maps and historical images are available in the **Mount Mercy University Busse Library, Special Collections: Grotto Archives**. All historical images identify photographer or mapmaker if known.

FIGURES NUMBERS: GEOGRAPHICAL DATA: SECTION 10

Figure # 1: BOUNDARY MAP/SKETCH MAP/SITE PLAN, William Lightner's Our Mother of Sorrows Grotto, Mount Mercy University, Linn County, Cedar Rapids, Iowa. Map by Anton Rajer 2001 revised by Jane Gilmor 2012. Solid black line marks **Property Boundary**. Dashed line shows **Central Shrine and Lagoon (non-extant) footprints**. List of site structures is keyed to *Table 1: Description of Grotto Structures*, Section 7, page 2.

Figure # 2: Table #1: KEY to Boundary Map/ Sketch Map/Site Plan in Figure #1, Description of Grotto Structures (within boundary lines)

Figure #3: Sketch Map/Site Plan, Key to Camera Locations for referenced photos of Grotto site and structures. William Lightner's Our Mother of Sorrow Grotto, Mount Mercy University, Linn County Cedar Rapids, Iowa. Map by Anton Rajer, 2001, revised by Jane Gilmor, 2012. **Solid Black Line Marks Property Boundary. For list of site structures and other elements see Figure #2, Table #1.**

Figure #4: SKETCH MAP/SITE PLAN, KEY TO CAMERA LOCATIONS for Photos of Grotto Structures, William Lightner's Our Mother of Sorrows Grotto, Mount Mercy University, Linn County, Cedar Rapids, Iowa, Map by Anton Rajer 2001 revised by Jane Gilmor 2012. Solid black line = **Property Boundary**

Figure # 5: Plat Map: Our Mother of Sorrows Grotto, Linn County, Cedar Rapids, Iowa, overview with Cedar River, NE Quadrant. Arrow locates campus, Google Maps, 2012

FIGURE NUMBERS FOR NARRATIVE DESCRIPTION: SECTION 7

Figure # 6: Floor plan/ elevation of Warde Arch, Our Mother of Sorrows Grotto, Mount Mercy University, Linn County, Cedar Rapids Iowa, map by Anton Rajer, 2001

Figure # 7: Floor Plan/elevation for Grotto Bridge, Our Mother of Sorrows Grotto, Mount Mercy University, Linn County, Cedar Rapids, Iowa, map by Anton Rajer, 2001

Figure #8: Floor Plan/Elevation Ten Commandments Structure, Our Mother of Sorrows Grotto, Mount Mercy University, Linn County, Cedar Rapids, Iowa, map by Anton Rajer, 2001

United States Department of the Interior
National Park Service

National Register of Historic Places
Continuation Sheet

Section Imbedded page 38 **Property name** Our Mother of Sorrows Grotto Historic District

County and State Linn County, Iowa

Figure # 9: Floor Plan: McAuley Arch, Our Mother of Sorrows Grotto, Mount Mercy University Campus, Linn County, Cedar Rapids, Iowa, map by Anton Rajer, 2012

FIGURE NUMBERS FOR HISTORICAL PHOTOGRAPHS (Imbedded Image Section)

Figure # 10: Our Mother of Sorrows Grotto, Linn County. IA, unknown, c. 1930s, overview of Grotto with pond off lagoon, Ten Commandments Structure in foreground, Grotto Bridge and Warde Arch immediately behind. Warde Hall in far background, camera facing NW, Mount Mercy University Busse Library Special Collections: Grotto Archives (same for all Figure #10 - #19 images).

Figure # 11: Our Mother of Sorrows Grotto, Linn County. IA, unknown, c. late 1930s, Isadora Duncan Scarf Dancers at May Crowning Ceremony with Grotto Bridge and Ten Commandments behind, camera facing SE

Figure # 12: Our Mother of Sorrows Grotto, Linn County, IA., unknown, c 1900-1930s, portraits of William H. Lightner, visionary architect and builder.

Figure # 13: Our Mother of Sorrows Grotto, Linn County, IA. Unknown, c. 1940s -50s, May Day Crowning Procession at Grotto site with McAuley Arch (center background), Bridge (middle ground left), and Ten Commandments (Right foreground behind figures), camera facing NE.

Figure # 14: Our Mother of Sorrows Grotto, Linn, Iowa, unknown, c. 1950's, Graduating Class on Grotto Bridge, camera facing SE.

Figure # 15: Our Mother of Sorrows Grotto, Linn, Iowa, unknown, 1974, removal of Grotto's Wall Shrine following draining of lagoon in 1970, camera facing SE.

Figure # 16: Our Mother of Sorrows Grotto, Linn, Iowa, Gilmor, 2001, Grotto Bridge and pond, Smithsonian American Heritage Save Outdoor Sculpture Restoration grant in process, camera facing NE.

Figure # 17: Our Mother of Sorrows Grotto, Linn, Iowa, unknown, 1941, Archbishop Francis Beckman and graduates at Warde Arch, camera facing N.

Figure # 18: Our Mother of Sorrows Grotto, Linn, Iowa, unknown, c. 1943, The Sisters of Mercy in front of Central Grotto Shrine and Lagoon (both non-extant), camera facing SW.

Figure #19: Our Mother of Sorrows Grotto, Linn County, Iowa, unknown, c 1946, image of girls in costume canoeing on the Grotto Lagoon during the reenactment of seven scenes from Iowa's history at Iowa Bicentennial Celebration, camera facing NE, The image was used in a 1967 Time Magazine article.

**United States Department of the Interior
National Park Service**

**National Register of Historic Places
Continuation Sheet**

Section Imbedded page 39 **Property name** Our Mother of Sorrows Grotto Historic District

County and State Linn County, Iowa

Figure # 20: Our Mother of Sorrows Grotto, Linn County, Iowa, unknown, c 1930s, unfinished image of Ten Commandments structure labeled "Shrine Mother of Sorrow, Cedar Rapid, IA." camera facing SE

Figure # 21: Our Mother of Sorrows Grotto, Linn County, Iowa, unknown, 2011, aerial watercolor rendering of Lightner's Grotto site in context of Mount Mercy University campus in 2011 (with Student Parking Lot "S" removed as planned for 2016)

United States Department of the Interior
National Park Service

National Register of Historic Places
Continuation Sheet

Section Imbedded page 40 Property name Our Mother of Sorrows Grotto Historic District

County and State Linn County, Iowa

Figure #1: BOUNDARY MAP/SKETCH MAP/SITE PLAN, William Lightner's Our Mother of Sorrows Grotto, Mount Mercy University, Linn County, Cedar Rapids, Iowa. Map by Anton Rager 2001 revised by Jane Gilmor 2012. Solid black line marks **Property Boundary**. Dashed line shows **Central Shrine and Lagoon (non-extant) footprints**. List of site structures within Boundary line is keyed to **Table 1: Description of Grotto Structures, Fig. #2** (see next page)

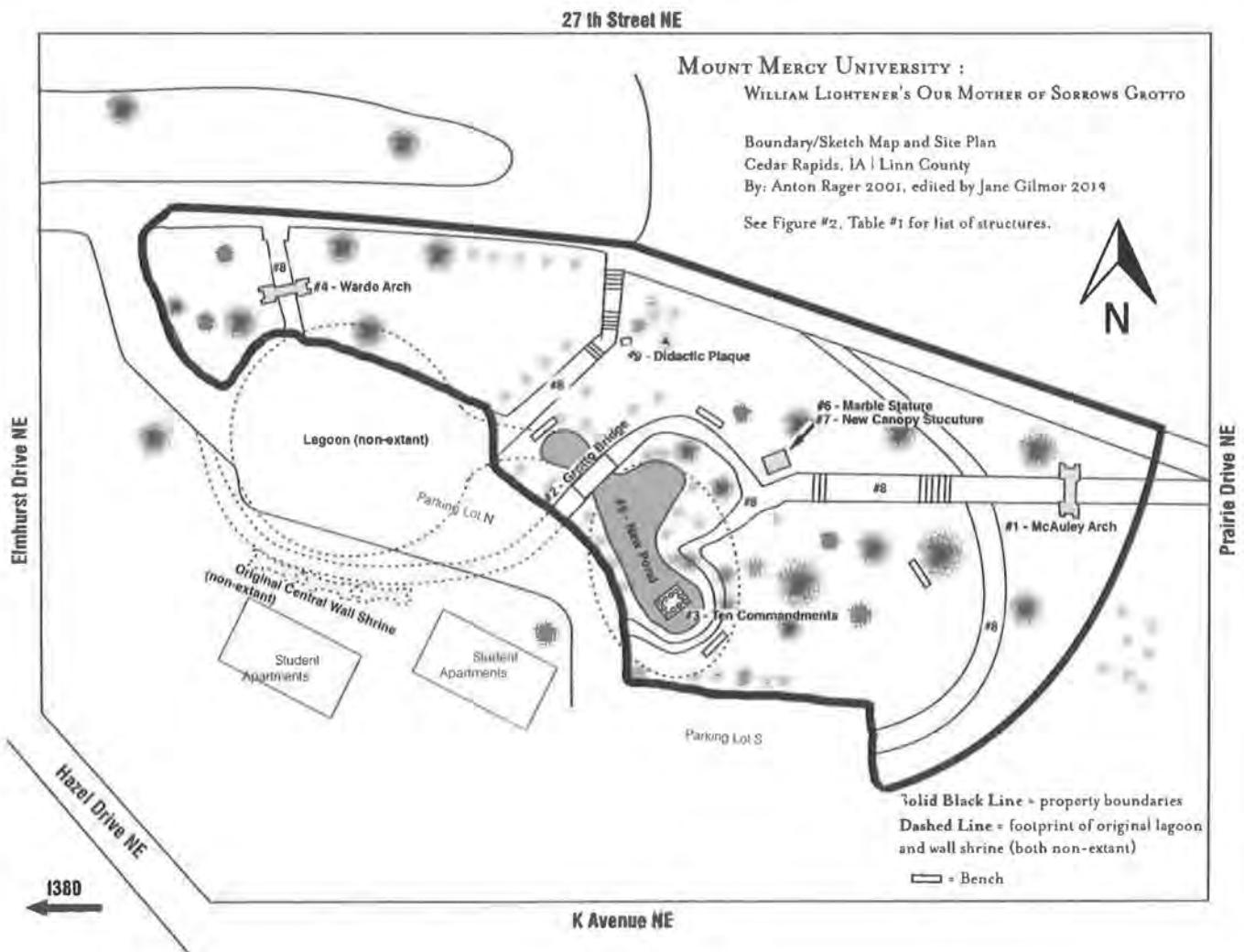

**United States Department of the Interior
National Park Service**

**National Register of Historic Places
Continuation Sheet**

Section Imbedded page 41 **Property name** Our Mother of Sorrows Grotto Historic District

County and State Linn County, Iowa

Figure #2: Table #1: KEY to Boundary Map/ Sketch Map/Site Plan: Description of Grotto Structures
List of site structures within Boundary line is keyed to **Figure #1 on previous page.**

#	NAME OF STRUCTURE	STATUS	DATE	PHOTO / FIG. NO.
#1	McAuley Arch	Contributing	1929-41	Photo #20, 21, 22, 23 Fig #6, 13
#2	Grotto Bridge	Contributing	1929-41	Photo #1,2,4,5,11,12, 13,14,15,16 Figure #7,10,11,13,14, 16,21
#3	Ten Commandments	Contributing	1929-32	Photo #1,2,3,4,5,6,7, 8,9,12,24,29 Figure #8,10,11,12,13,14,20,21
#4	Warde Arch	Contributing	1929-32	Photo 10,17,18,19 Figure #9,10,17
#5	New Pond	Non- contributing	2002	Photo #1, 2, 3, 4, 5 11,12,24,x29 Figure# 21
#6	Italian Marble Statue of Virgin Mary	Contributing	c.1949	Photo #1, 2, 12, 24, 25, 26, 27, 29 Fig # 18, 21
#7	New Canopy Structure	Non- contributing	2004	Photo #1, 2 12, 24, 25, 26, 27 Fig. #21
#8	Walkway Systems and Gardens, including Walk of Mercy (2011)	Non- contributing	2002	Photo #1, 2, 3, 4, 5, 10,12,14,21,24,25,29 Fig# #21
#9	Didactic Plaque	Non- contributing	2001	Photo #28

United States Department of the Interior
National Park Service

National Register of Historic Places
Continuation Sheet

Section Imbedded page 42 Property name Our Mother of Sorrows Grotto Historic District

County and State Linn County, Iowa

Figure # 3: SKETCH MAP/SITE PLAN, KEY TO CAMERA LOCATIONS for Photos of Grotto Structures, William Lightner's Our Mother of Sorrows Grotto, Mount Mercy University, Linn County, Cedar Rapids, Iowa
Map by Anton Rager 2001 revised by Jane Gilmore 2012. Solid black line marks **Property Boundary**. List of site structures Keyed to **Figure #2: Table #1: KEY to Boundary Map/ Sketch Map/Site Plan: Grotto Structures N↑**

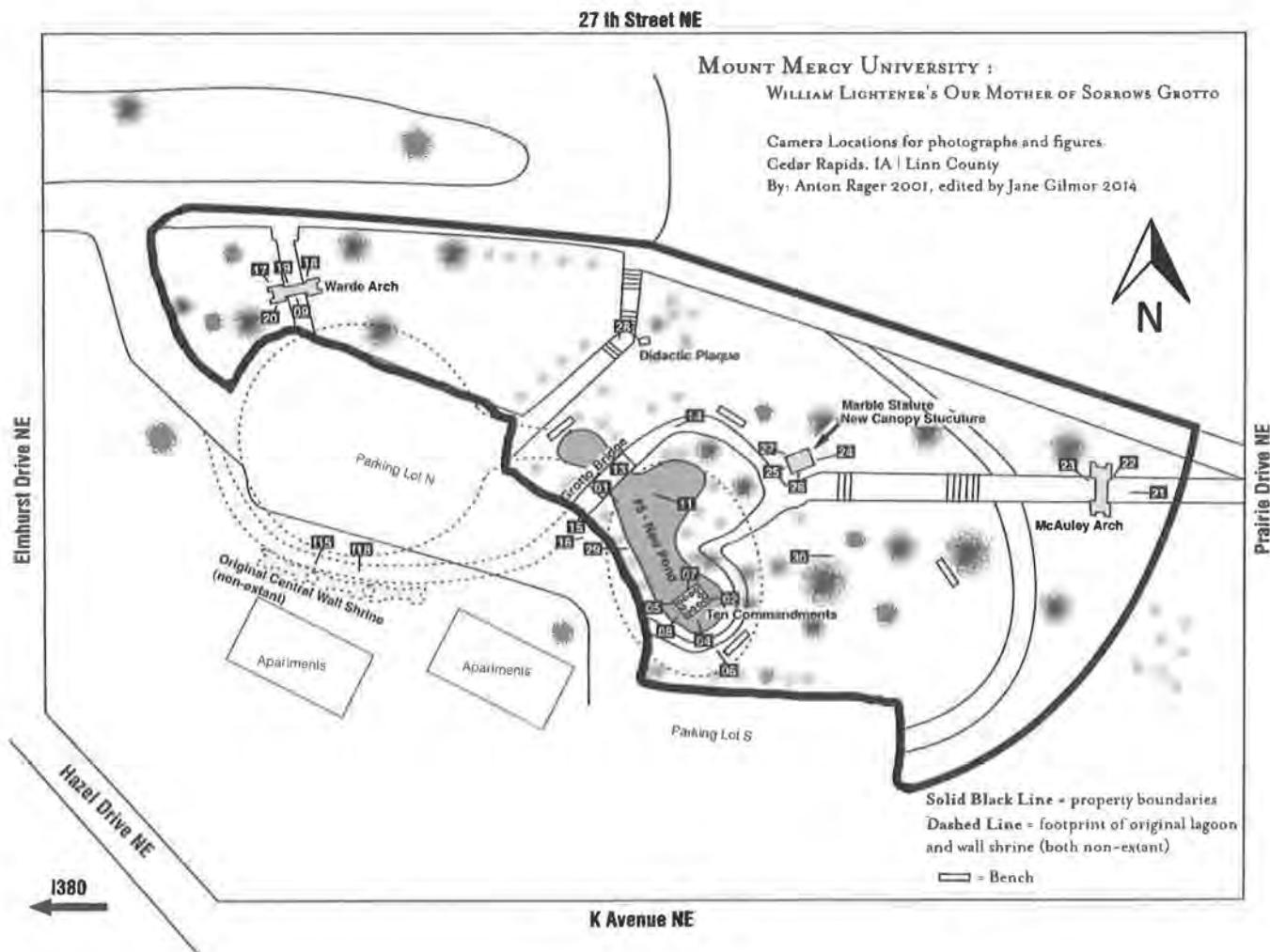

**United States Department of the Interior
National Park Service**

**National Register of Historic Places
Continuation Sheet**

Section Imbedded page 43 **Property name** Our Mother of Sorrows Grotto Historic District

County and State Linn County, Iowa

Figure # 4: Sketch Maps of Our Mother of Sorrows Grotto and Mount Mercy University Campus, Linn County, Cedar Rapids, Iowa NE Quadrant, 44.5 acres: Linn County, Cedar Rapids, Iowa, MMU Public Relations Dept. 2010 (Not to scale) (Note North is NOT top of Page: see markings)

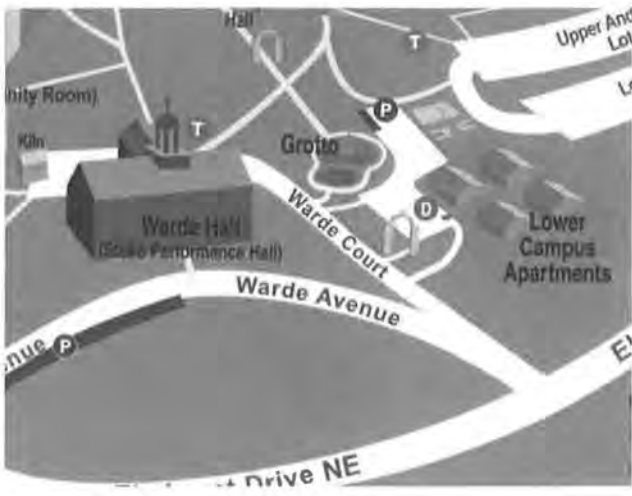
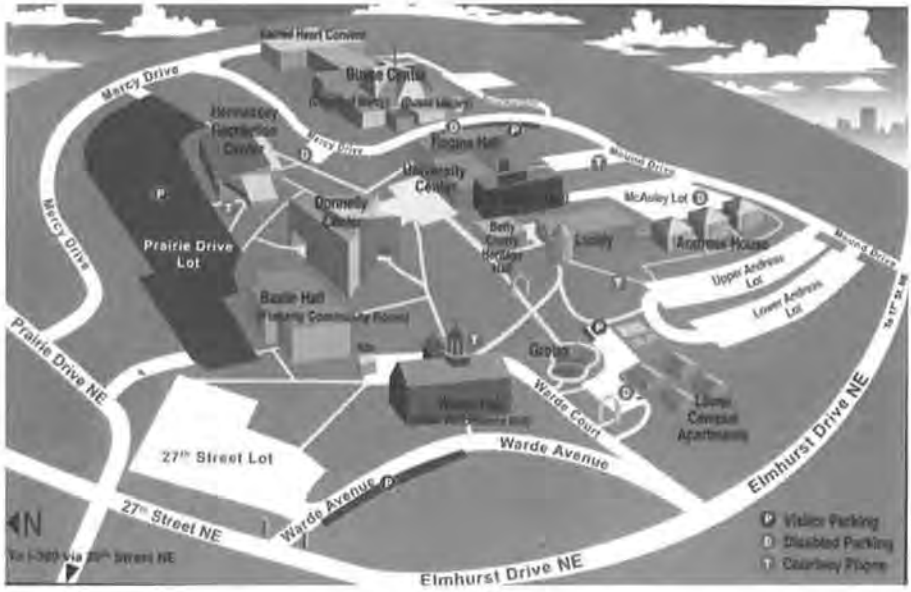

United States Department of the Interior
National Park Service

National Register of Historic Places
Continuation Sheet

Section Imbedded page 44 Property name Our Mother of Sorrows Grotto Historic District

County and State Linn County, Iowa

← I380 N ↑



Figure # 5: Plat Map: Our Mother of Sorrows Grotto, Linn County, Cedar Rapids, Iowa, overview with Cedar River, NE Quadrant. Arrow locates campus, Google Maps, 2013

United States Department of the Interior
National Park Service

National Register of Historic Places
Continuation Sheet

Section Imbedded page 45 Property name Our Mother of Sorrows Grotto Historic District

County and State Linn County, Iowa

Cedar Rapids, Iowa

#1 McAuley Arch

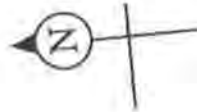

1" = 1'

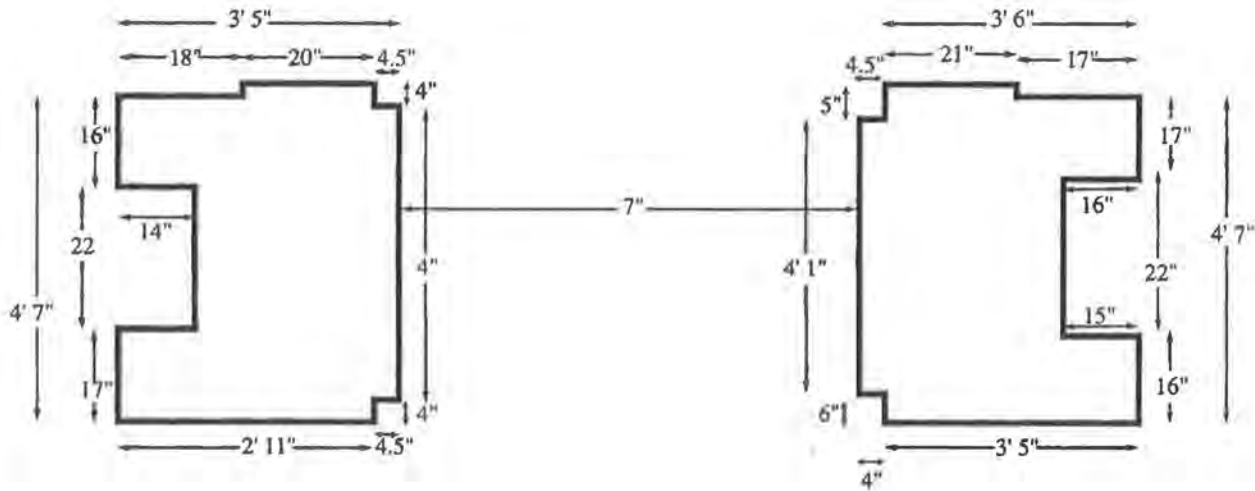

Figure # 6: Floor Plan: McAuley Arch, Our Mother of Sorrows Grotto, Mount Mercy University Campus, Linn County, Cedar Rapids, Iowa, map by Anton Rajer, 2001

**United States Department of the Interior
National Park Service**

**National Register of Historic Places
Continuation Sheet**

Section Imbedded **page** 46 **Property name** Our Mother of Sorrows Grotto Historic District

County and State Linn County, Iowa

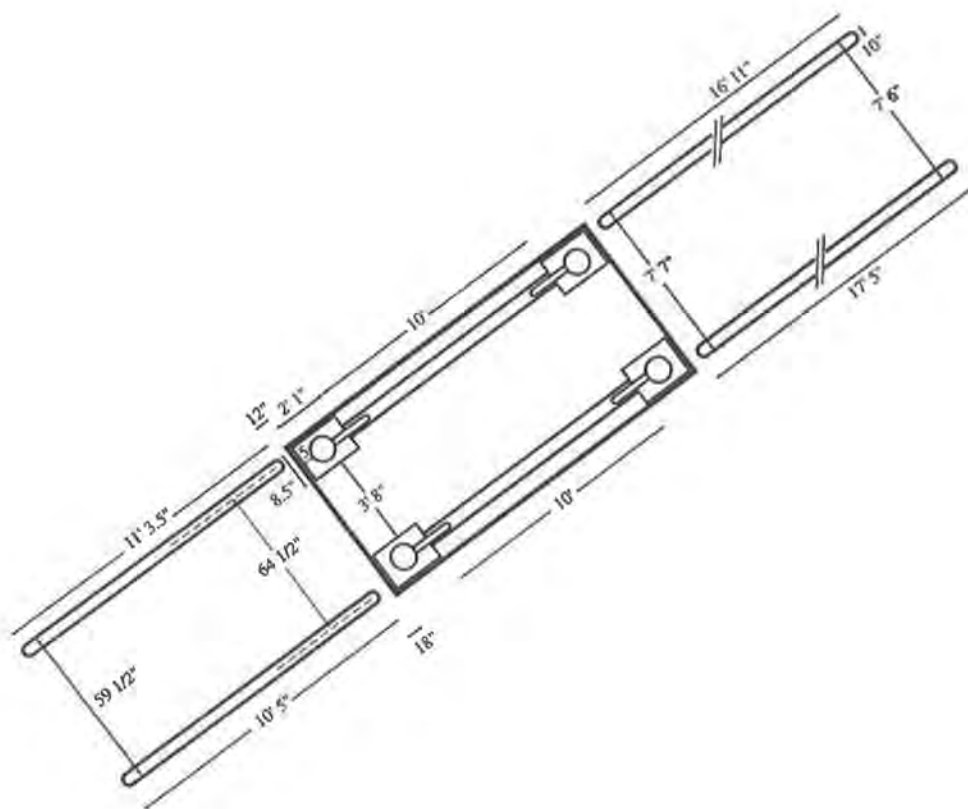

Figure # 7: Floor Plan/elevation plan for Grotto Bridge, Our Mother of Sorrows Grotto, Mount Mercy University, Linn County, Cedar Rapids, Iowa, map by Anton Rajer, 2002

United States Department of the Interior
National Park Service

National Register of Historic Places
Continuation Sheet

Section Imbedded page 47 Property name Our Mother of Sorrows Grotto Historic District

County and State Linn County, Iowa

Cedar Rapids, Iowa

#3 Ten Commandments Monument



1" = 1'



Radius of columns between 4" and 5"

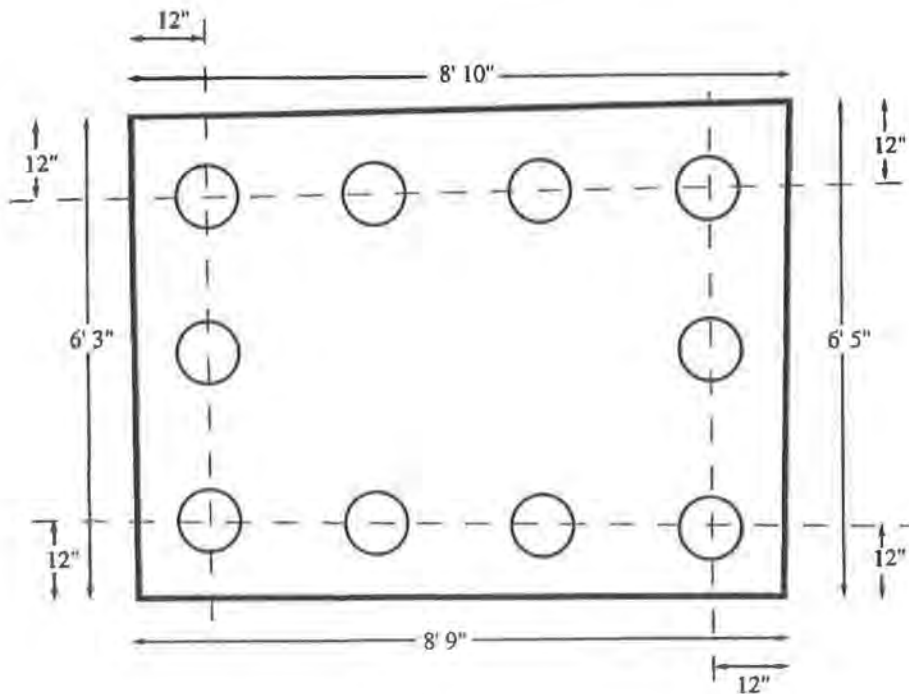

July 2002

Figure # 8: Floor Plan/Elevation for Ten Commandments Structure, Our Mother of Sorrows Grotto, Mount Mercy University Cedar Rapids, Iowa, Linn County, map by Anton Rajer, 2002

United States Department of the Interior
National Park Service

National Register of Historic Places
Continuation Sheet

Section Imbedded page 48 Property name Our Mother of Sorrows Grotto Historic District

County and State Linn County, Iowa



Figure # 9: Floor plan/ elevation map of **Warde Arch**, Our Mother of Sorrows Grotto, Mount Mercy University, Cedar Rapids Iowa Linn County, map by Anton Rajer, 2002

Cedar Rapids, Iowa

#4 Warde Arch

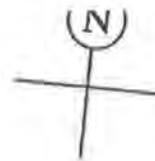

1" = 1'

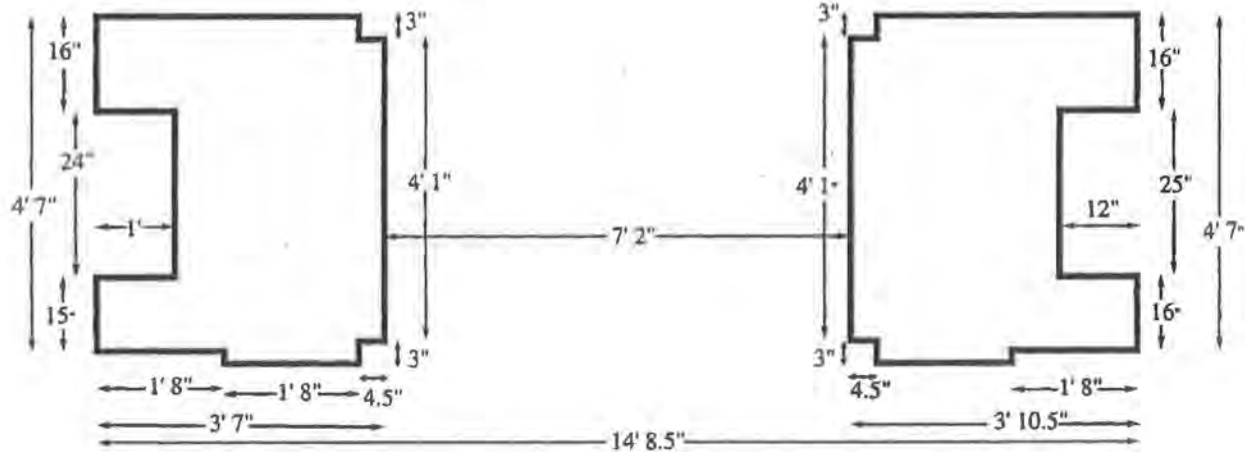

**United States Department of the Interior
National Park Service**

**National Register of Historic Places
Continuation Sheet**

Section Imbedded **page** 49 **Property name** Our Mother of Sorrows Grotto Historic District
County and State Linn County, Iowa



Figure 10: Our Mother of Sorrows Grotto, Linn County, IA, unknown, c. 1930s, overview of Grotto with pond off lagoon, Ten Commandments Structure in foreground, Grotto Bridge and Warde Arch immediately behind. Warde Hall in far background, camera facing NW.

**United States Department of the Interior
National Park Service**

**National Register of Historic Places
Continuation Sheet**

Section Imbedded **page** 50 **Property name** Our Mother of Sorrows Grotto Historic District

County and State Linn County, Iowa



Figure 11: Our Mother of Sorrows Grotto, Linn County, IA, unknown, c. late 1930s, Isadora Duncan Scarf Dancers at May Crowning Ceremony with Grotto Bridge, Ten Commandments behind, camera facing SE.

**United States Department of the Interior
National Park Service**

**National Register of Historic Places
Continuation Sheet**

Section Imbedded **page** 51 **Property name** Our Mother of Sorrows Grotto Historic District

County and State Linn County, Iowa



Figure 12: Our Mother of Sorrows Grotto, Linn County, IA., unknown, c 1900-1930s, portraits of William H. Lightner, visionary artist and builder.

**United States Department of the Interior
National Park Service**

**National Register of Historic Places
Continuation Sheet**

Section Imbedded **page** 52 **Property name** Our Mother of Sorrows Grotto Historic District

County and State Linn County, Iowa



Figure 13: Our Mother of Sorrows Grotto, Linn County, IA. unknown, c. 1940s -50s, May Day Crowning Procession at Grotto site with McAuley Arch (center background), Bridge (middle ground left), and Ten Commandments (Right foreground behind figures), camera facing NE.

**United States Department of the Interior
National Park Service**

**National Register of Historic Places
Continuation Sheet**

Section Imbedded **page** 53 **Property name** Our Mother of Sorrows Grotto Historic District

County and State Linn County, Iowa



Figure 14: Our Mother of Sorrows Grotto, Linn County, IA., unknown, c. 1950s, Graduating Class portrait on Grotto Bridge, camera facing SE.

**United States Department of the Interior
National Park Service**

**National Register of Historic Places
Continuation Sheet**

Section Imbedded **page** 54 **Property name** Our Mother of Sorrows Grotto Historic District

County and State Linn County, Iowa



Figure 15: Our Mother of Sorrows Grotto, Linn county, Iowa, unknown, 1974, removal of Large Wall Shrine, camera facing SE.

**United States Department of the Interior
National Park Service**

**National Register of Historic Places
Continuation Sheet**

Section Imbedded page 55 Property name Our Mother of Sorrows Grotto Historic District
County and State Linn County, Iowa



Figure 16: Our Mother of Sorrows Grotto, Linn County, IA. Gilmor, 2001, Grotto Bridge and New Pond, Smithsonian American Heritage Save Outdoor Sculpture restoration grant in process, camera facing SE.

United States Department of the Interior
National Park Service

National Register of Historic Places
Continuation Sheet

Section Imbedded page 56 Property name Our Mother of Sorrows Grotto Historic District

County and State Linn County, Iowa



Figure 17: Our Mother of Sorrows Grotto, Linn County, IA.
unknown, 1940s, Archbishop Francis Beckman and graduating class,
camera facing NW, process, camera facing SE.

**United States Department of the Interior
National Park Service**

**National Register of Historic Places
Continuation Sheet**

Section Imbedded page 57 **Property name** Our Mother of Sorrows Grotto Historic District

County and State Linn County, Iowa

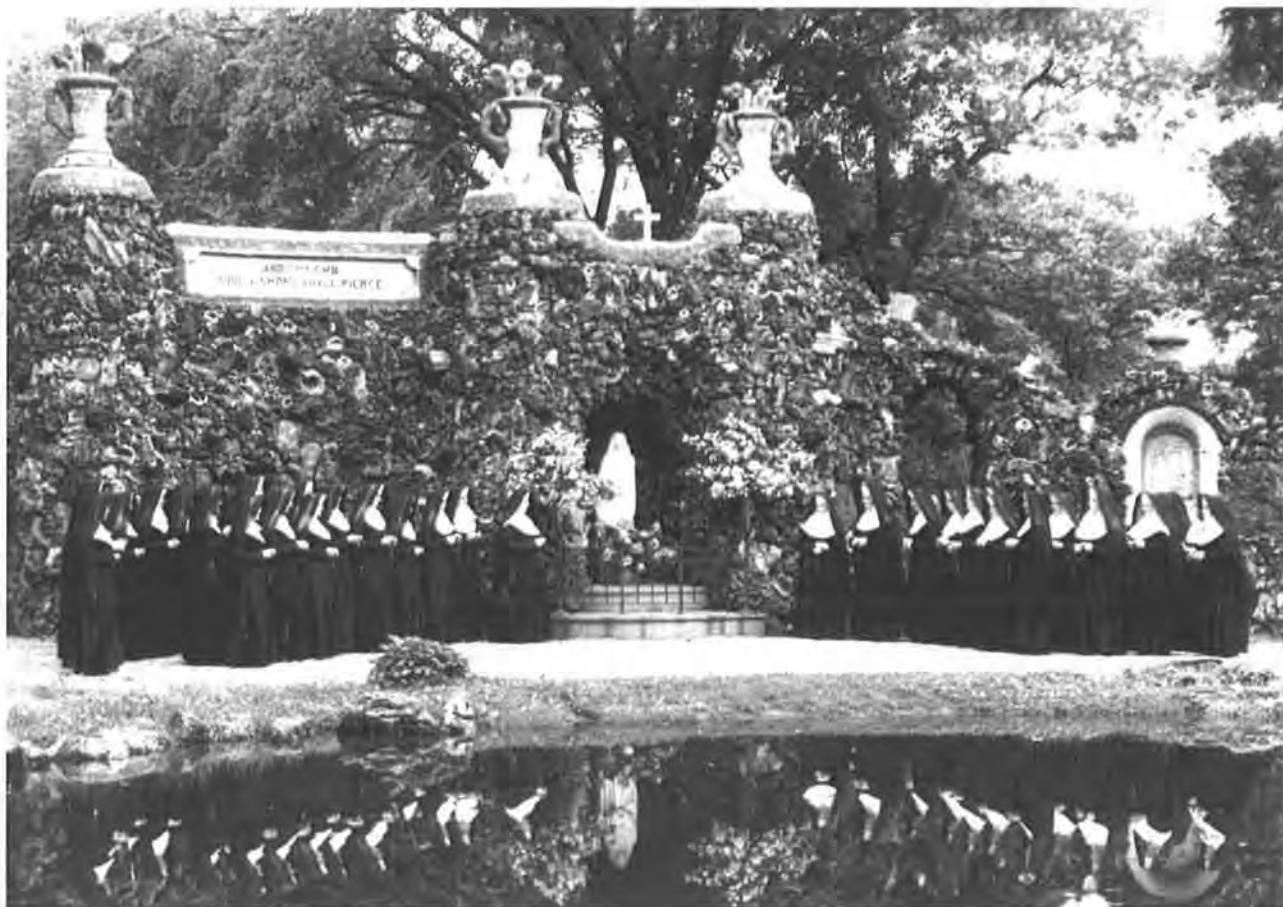

Figure 18: Our Mother of Sorrows Grotto, Linn County, IA., unknown, 1950s, Sisters of Mercy in front of Wall Shrine housing Virgin Mary Statue, camera facing SE.

**United States Department of the Interior
National Park Service**

**National Register of Historic Places
Continuation Sheet**

Section Imbedded page 58 Property name Our Mother of Sorrows Grotto Historic District

County and State Linn County, Iowa



Figure 19: Our Mother of Sorrows Grotto, Linn County, Iowa, unknown, c 1946, image of girls in costume canoeing on the Grotto Lagoon during the reenactment of seven scenes from Iowa's history at Iowa Bicentennial Celebration, camera facing NE, The image was used in a 1967 Time Magazine article.

United States Department of the Interior
National Park Service

National Register of Historic Places
Continuation Sheet

Section Imbedded page 59 Property name Our Mother of Sorrows Grotto Historic District
County and State Linn County, Iowa



Figure 20: Our Mother of Sorrows Grotto, Linn County, Iowa, unknown, c 1930s, unfinished image of Ten commandments structure labeled "Shrine Mother of Sorrow, Cedar Rapid, IA." camera facing SE.

**United States Department of the Interior
National Park Service**

**National Register of Historic Places
Continuation Sheet**

Section Imbedded page 60 Property name Our Mother of Sorrows Grotto Historic District

County and State Linn County, Iowa



Figure 21: Our Mother of Sorrows Grotto, Linn County, Iowa, unknown, 2011, aerial watercolor rendering of Lightner's Grotto site in context of Mount Mercy University campus in 2011 (with Student Parking Lot "S" removed as planned for 2016).



THOU SHALT NOT FORSWARE
THOU SHALT NOT KILL
THOU SHALT NOT COMMIT ADULTERY
THOU SHALT NOT BEAR FALSE WITNESS











A stone wall with a decorative border of blue and yellow triangles. The text is written in gold on a red background. The text is the first three commandments of the Ten Commandments.

THOU SHALT NOT HAVE STRANGE GODS BEFORE ME
THOU SHALT NOT TAKE THE NAME OF THE LORD THY GOD IN VAIN
REMEMBER THAT THOU KEEP HOLY THE SABBATH DAY

















MY GRACE IS SUFFICIENT
FOR THE



MY GRACE IS SUFFICIENT
FOR THEE





BE THE CRETS OF









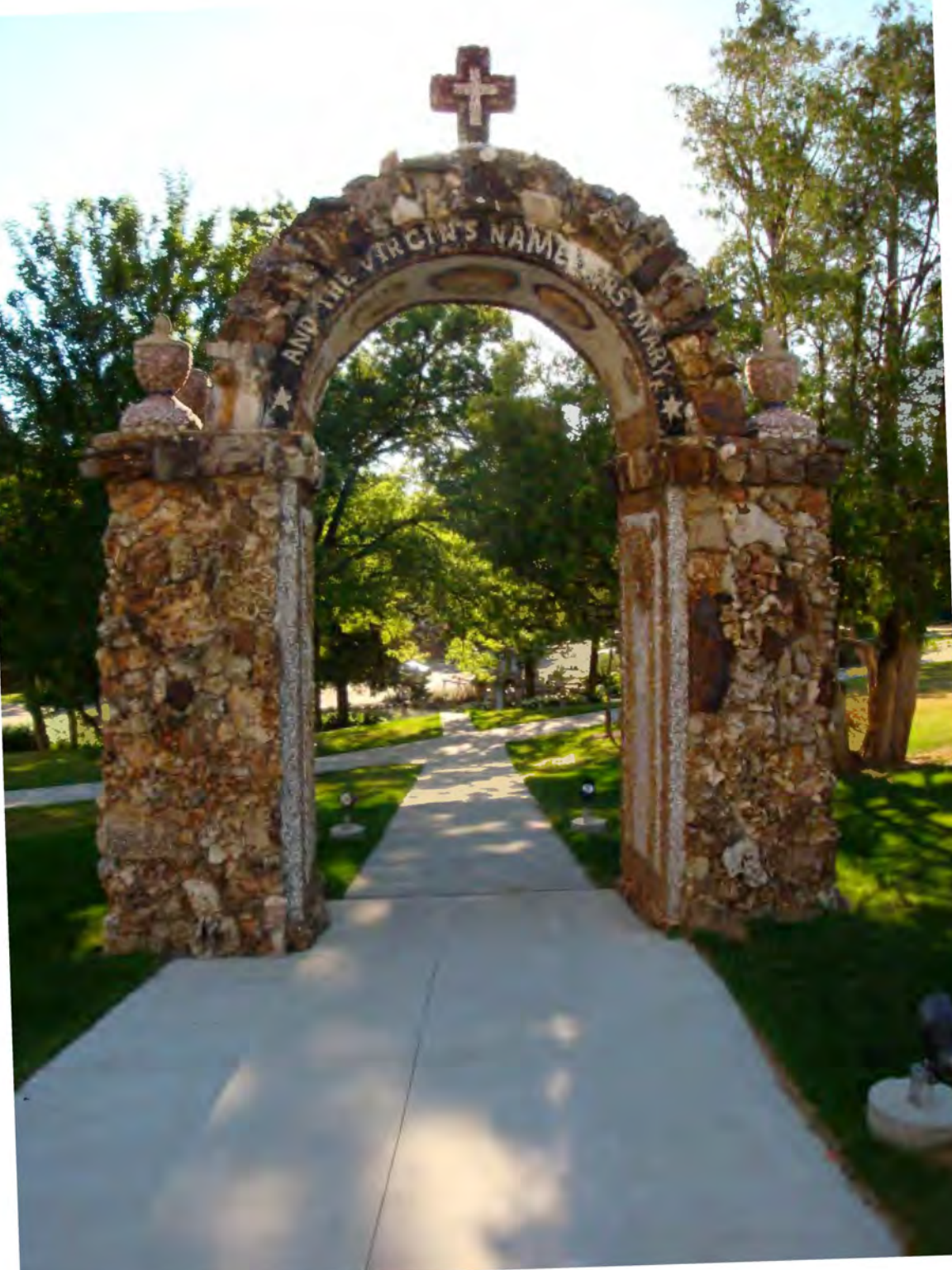











Our Mother of Sorrows Grotto

The grotto was built in 1911 by the Sisters of the Holy Family, who were the first to settle in the area. The grotto was built in the style of the Holy Sepulchre.

A local artist, John J. Conroy, designed the grotto. It was built in the style of the Holy Sepulchre. The grotto was built in the style of the Holy Sepulchre.

The grotto was built in 1911 by the Sisters of the Holy Family, who were the first to settle in the area. The grotto was built in the style of the Holy Sepulchre.

The grotto was built in 1911 by the Sisters of the Holy Family, who were the first to settle in the area. The grotto was built in the style of the Holy Sepulchre.

The grotto was built in 1911 by the Sisters of the Holy Family, who were the first to settle in the area. The grotto was built in the style of the Holy Sepulchre.

The grotto was built in 1911 by the Sisters of the Holy Family, who were the first to settle in the area. The grotto was built in the style of the Holy Sepulchre.



The Mother of Sorrows Grotto, built in 1911 by the Sisters of the Holy Family, who were the first to settle in the area. The grotto was built in the style of the Holy Sepulchre.



The Mother of Sorrows Grotto, built in 1911 by the Sisters of the Holy Family, who were the first to settle in the area. The grotto was built in the style of the Holy Sepulchre.





UNITED STATES DEPARTMENT OF THE INTERIOR
NATIONAL PARK SERVICE

NATIONAL REGISTER OF HISTORIC PLACES
EVALUATION/RETURN SHEET

REQUESTED ACTION: RESUBMISSION

PROPERTY NAME: Our Mother of Sorrows Grotto Historic District

MULTIPLE NAME:

STATE & COUNTY: IOWA, Linn

DATE RECEIVED: 12/05/14

DATE OF PENDING LIST:

DATE OF 16TH DAY:

DATE OF 45TH DAY:

1/21/15

DATE OF WEEKLY LIST:

REFERENCE NUMBER: 14000213

DETAILED EVALUATION:

ACCEPT RETURN REJECT 1/21/2015 DATE

ABSTRACT/SUMMARY COMMENTS:

On resubmission all of the issues detailed in the National Register Return sheet dated 5/15/2014 have been addressed. Boundary has been redrawn to exclude non-contributing areas

RECOM./CRITERIA accept c

REVIEWER Patricia Anderson

DISCIPLINE Historian

TELEPHONE _____

DATE 1/21/2015

DOCUMENTATION see attached comments Y/N see attached SLR Y/N

UNITED STATES DEPARTMENT OF THE INTERIOR
NATIONAL PARK SERVICE

NATIONAL REGISTER OF HISTORIC PLACES
EVALUATION/RETURN SHEET

REQUESTED ACTION: NOMINATION

PROPERTY NAME: Our Mother of Sorrows Grotto Historic District

MULTIPLE NAME:

STATE & COUNTY: IOWA, Linn

DATE RECEIVED: 4/02/14 DATE OF PENDING LIST: 4/25/14
DATE OF 16TH DAY: 5/12/14 DATE OF 45TH DAY: 5/19/14
DATE OF WEEKLY LIST:

REFERENCE NUMBER: 14000213

REASONS FOR REVIEW:

APPEAL: N DATA PROBLEM: N LANDSCAPE: N LESS THAN 50 YEARS: N
OTHER: N PDIL: N PERIOD: N PROGRAM UNAPPROVED: N
REQUEST: Y SAMPLE: N SLR DRAFT: N NATIONAL: N

COMMENT WAIVER: N

ACCEPT RETURN REJECT 5/15/2014 DATE

ABSTRACT/SUMMARY COMMENTS:

See attached Return Sheet for detailed comment.

RECOM./CRITERIA Return
REVIEWER Patricia Andrews DISCIPLINE Historian
TELEPHONE _____ DATE 5/15/2014

DOCUMENTATION see attached comments Y/N see attached SLR Y/N

If a nomination is returned to the nominating authority, the nomination is no longer under consideration by the NPS.



United States Department of the Interior

NATIONAL PARK SERVICE
1849 C Street, N.W.
Washington, D.C. 20240

IN REPLY REFER TO:

United States Department of the Interior National Park Service

National Register of Historic Places Evaluation/Return Sheet

Property Name: Our Mother of Sorrows Grotto Historic District
State and County: IOWA, Linn
Reference Number: 14000213

Reason for Return:

While the Our Mother of Sorrows Grotto Historic District appears to be significant under National Register of Historic Places Criterion C, in the areas of significance of Art and Architecture, the nomination must be returned for substantive problems with the boundary and for a number of technical issues with the nomination form.

Boundary: The boundary selected to define the district includes large areas of non-contributing surface automobile parking lots, a non-contributing student apartment building, and portion of a second non-contributing student apartment building, as shown in Figure #1: Boundry Map (imbedded page 38). The boundary should be redrawn to follow the edges of the greenspace along the edge of the grotto grounds and to exclude Parking Lots S and N and the non-contributing apartment buildings. Please provide a new boundary description, boundary map, and revised acreage figure in Section 10 of the nomination. After the boundary is redrawn, please change the resource count found in Section 5 of the form and in the inventory shown in Figure #2, Table #1 (imbedded page 39).

Resource Count: Please note that there is a discrepancy in the resource count shown in Section 5 of the nomination form and in the inventory shown in Figure #2, Table #1 (imbedded page 39). Section 5 of the form shows 6 contributing resources, while the inventory (Figure #2, Table #1) lists 5 contributing resources. Please reconcile the resource count.

Section 8/ Significant Person Category: In the Statement of Significance (Section 8), the name William H. Lightner has been entered under the data category Significant Person. Please note that this section of the form is to be completed only if the property is nominated under National Register Criterion B for historic association with the named person. Since the district is not nominated under Criterion B, please delete the name under the Significant Person category.

UTM: In Section 10 of the form (Geographical Data) the Easting and Northing UTM Coordinates have

been reversed. Please revise the form by switching the coordinates.

A handwritten signature in black ink that reads "Patrick Andrus". The signature is written in a cursive style with a large initial "P".

Patrick Andrus, Historian
National Register of Historic Places
patrick_andrus@nps.gov
5/15/2014

IOWA DEPARTMENT OF
CULTURAL AFFAIRS

TERRY E. BRANSTAD, GOVERNOR
KIM REYNOLDS, LT. GOVERNOR

MARY COWNIE, DIRECTOR
CHRIS KRAMER, DEPUTY DIRECTOR

IOWA
ARTS
COUNCIL

PRODUCE
IOWA

STATE HISTORICAL
SOCIETY OF IOWA

STATE HISTORICAL
MUSEUM OF IOWA

STATE HISTORICAL
LIBRARY & ARCHIVES

STATE
HISTORIC
SITES

STATE HISTORIC
PRESERVATION
OFFICE OF IOWA

IOWA
HISTORICAL
FOUNDATION

March 27, 2014

Carol Shull, Chief
National Park Service
National Register of Historic Places
1201 Eye Street, N.W.-- 8th Floor
Washington, D.C. 20005



Dear Ms. Shull:

The following National Register nomination(s) are enclosed for your review and listing if acceptable.

- North Grand Avenue Residential Historic District, North Grand Avenue from 9th Street to 18th Street & 1st Avenue West to 1st Avenue East, Spencer, Clay County, Iowa
- Our Mother of Sorrows Grotto Historic District, 1330 Elmhurst Drive, NE, Cedar Rapids, Linn County, Iowa

Sincerely,

Elizabeth Foster Hill, Manager
National Register and Tax Incentive Programs

IOWA DEPARTMENT OF
CULTURAL AFFAIRS

MARY COWNIE, DIRECTOR
CHRIS KRAMER, DEPUTY DIRECTOR

TERBY E. BRANSTAD, GOVERNOR
JIM REYNOLDS, AT GOVERNOR



IOWA
ARTS
COUNCIL

PRODUCE
IOWA

STATE HISTORICAL
SOCIETY OF IOWA

STATE HISTORICAL
MUSEUM OF IOWA

STATE HISTORICAL
LIBRARY & ARCHIVES

STATE
HISTORIC
SITES

STATE HISTORIC
PRESERVATION
OFFICE OF IOWA

IOWA
HISTORICAL
FOUNDATION

December 4, 2014

Carol Shull, Interim Keeper
National Park Service
National Register of Historic Places
1201 Eye Street, N.W.-- 8th Floor
Washington, D.C. 20005

Dear Ms. Shull:

The following National Register nomination(s) are enclosed for your review and listing if acceptable.

- Forest Park Historic District, Mason City, Cerro Gordo County, Iowa
- Fort Madison High School, Fort Madison, Lee County, Iowa
- Downtown Commercial Historic District, Burlington, Des Moines County, Iowa
- Our Mother of Sorrows Grotto Historic District, Cedar Rapids, Linn County Iowa
 - o (Revised from SLR – topo map remained at the NPS)

Thank you for your consideration.

Sincerely,

Elizabeth Foster Hill
National Register