

United States Department of the Interior
National Park Service

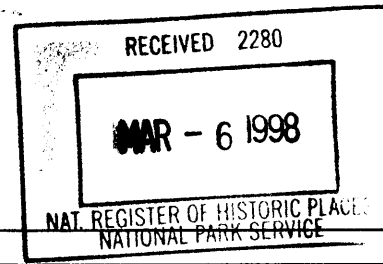

NATIONAL REGISTER OF HISTORIC PLACES REGISTRATION FORM

1. Name of Property

historic name: Foxx-Cox House
other names/site number:

2. Location

street & number: 402 Monticello Street not for publication ___
city or town: Bogue Chitto vicinity ___
state: Mississippi code MS county Lincoln code 85 zip code 39629

3. State/Federal Agency Certification

As the designated authority under the National Historic Preservation Act of 1986, as amended, I hereby certify that this nomination ___ request for determination of eligibility meets the documentation standards for registering properties in the National Register of Historic Places and meets the procedural and professional requirements set forth in 36 CFR Part 60. In my opinion, the property meets ___ does not meet the National Register Criteria. I recommend that this property be considered significant ___ nationally ___ statewide locally. (___ See continuation sheet for additional comments.)

Kenneth H. P. Pearl FEB. 19, 1998
Signature of certifying official Date

Deputy State Historic Preservation Officer
State or Federal agency and bureau

In my opinion, the property ___ meets ___ does not meet the National Register criteria. (___ See continuation sheet for additional comments.)

Signature of commenting or other official Date

State or Federal agency and bureau

4. National Park Service Certification

I, hereby certify that this property is:
 entered in the National Register
___ See continuation sheet.
___ determined eligible for the
National Register
___ See continuation sheet.
___ determined not eligible for the
National Register
___ removed from the National Register
___ other (explain): _____

Edson H. Beall 4.1.98
Signature of the Keeper Date of Action

5. Classification

Ownership of Property: Private

Number of Resources within Property:
(Do not include previously listed resources in the count)

Category of Property: Building

Contributing	Noncontributing	
1	1	buildings
		sites
		structures
		objects
1	1	Total

Name of related multiple property listing: N/A

Number of contributing resources previously listed in the National Register: N/A

6. Function or Use

Historic Functions: DOMESTIC: single dwelling
DOMESTIC: secondary structure

Current Functions: COMMERCE/TRADE: professional

7. Description

Architectural Classification(s): LATE VICTORIAN: Queen Anne

Materials:

foundation: BRICK
roof: METAL: tin
walls: WOOD: weatherboard
other

Narrative Description:

See Continuation Sheets

**United States Department of the Interior
National Park Service**

**NATIONAL REGISTER OF HISTORIC PLACES
CONTINUATION SHEET**

Section: 7

Page: 1

Foxx-Cox House
Bogue Chitto, Lincoln County, MS

NARRATIVE DESCRIPTION

Located on Monticello Street, on the western edge of the rural town of Bogue Chitto, Lincoln County, Mississippi, the Foxx-Cox House is the grandest house still remaining from Bogue Chitto's time of prosperity during the late 1800s and early 1900s.

The town of Bogue Chitto is situated just east of the Bogue Chitto River and consists of a grid of approximately ten blocks. The Foxx-Cox House is located on the northwestern corner of the roughly gridded street pattern within what were the town's limits before it lost its incorporation in the 1920s. Today, Bogue Chitto is a true example of a rural town, with large yards used for grazing livestock, chickens, and other farm animals. In its heyday, however, the town was probably a bustling hamlet in the midst of the great pine forest that stretched across much of Georgia, Alabama, Florida, and Mississippi. The terrain of this area is generally flat or gently rolling.

The Foxx-Cox House is a one-story, frame house with hipped roof and three cross gables, built in the Queen Anne style. The original structure was roughly rectangular with two chamfered bay windows breaking the plane of the wall on the front (north) and side (east) facades. A porch and room addition, which maintained the style of the original building, were constructed in the rear during the 1930s, creating an L-shape. In turn, the rear porch was partially enclosed during the 1980s renovation to office space. None of these changes affected the main facades of the building.

The foundation of the house is continuous brick with vents, although originally it probably featured brick piers and has recently been infilled. The original portion of the house is sided in 1 x 6" drop siding, while the 1930s addition has thinner 1 x 4" drop siding. There are also three interior chimneys that are symmetrically located along the building's axis. The c1895 chimneys are marked with decorative corbelling while the 1930s chimney is characterized by its chimney cap. The house is distinguished by three cross gables that are closed with a tin pent roof and feature identical octagonal and square imbricated shingling with a central jigsaw vent. The two gables with chamfered bays also feature decorative gable scrollwork under the frieze. All eaves are boxed and the cornice and friezes are plain.

The north facade is dominated by two gables that off-set its hipped roof. The five-bay facade is asymmetrical and reads window, door, window, window, window. All windows are four-over-four double-hung sash with wooden frames. A wraparound porch on the north and east elevations dominates the facade. The porch is constructed with beadboard and has vaulted beadboard ceilings and two exterior entrances. The importance of spindlework to a Queen Anne house is easily demonstrated in the elaborate

**United States Department of the Interior
National Park Service**

**NATIONAL REGISTER OF HISTORIC PLACES
CONTINUATION SHEET**

Section: 7

Page: 2

Foxx-Cox House
Bogue Chitto, Lincoln County, MS

details of the Foxx-Cox House. The gables feature intricate ornaments including square imbricated shingles and elaborately decorated wooden vents. The wraparound porch features delicate porch supports, lace-like brackets, a plain frieze and cornice, and eight-inch baseboards. The decorative details are continued on the main entrance with its one-light-and-three-panel door surrounded with two-light sidelights and four-light transom. The door surrounds have carvings that match the interior corner block paterae.

The west elevation has seven bays of four-over-four double-hung sash windows with the southernmost window decorated with squared, stained-glass panes. This elevation clearly shows the sympathetic 1930s ell addition. The ell is slightly recessed from the original structure in order to not distract from the house's overall appearance.

The south elevation is composed of a single three-over-one double-hung sash window. This elevation is the rear of the 1930s addition.

The secondary facade, or east elevation, is characterized with six-bays and the recessed 1930s addition. The original section of the house features four-over-four double-hung sash windows with wooden surrounds. A side, all-panel door is located on the wraparound porch and has a simple wooden surround. A cross gable dominates the c1895 structure. This gable is similar to those on the north facade with its decorative spindlework, square imbricated shingles, elaborate wooden vents, and lace-like corner brackets. The 1930s ell is very sympathetic to the main structure in its design, dimensions, and materials. The ell received further alterations in the 1980s when a section of the rear porch was filled in to provide office space. The enclosing of the porch was done with glass windows in order to retain the visual appearance of an open porch.

The interior of the house has been renovated for use as office space. However, none of these changes have directly affected the house's original floor plan. The house retains its central hall with two rooms on either side. As with most turn-of-the-century homes, the front two rooms possess a higher degree of architectural detail since they functioned as the social rooms while the back two rooms and hallway have less ornamentation. As for the ell and rear porch, they are still utilitarian in nature.

The Foxx-Cox House retains a high degree of its interior architectural details including an elaborate hall screen and original mantelpieces featuring decorative cable molding and brackets. The floors throughout the house are 1"x 3" or 4" sawn-lumber pine. The interior door and window surrounds are decorated with corner block paterae. All interior doorways are four or five-panel doors with single-light transoms. All

**United States Department of the Interior
National Park Service**

**NATIONAL REGISTER OF HISTORIC PLACES
CONTINUATION SHEET**

Section: 7

Page: 3

Foxx-Cox House
Bogue Chitto, Lincoln County, MS

four of the original c1895 rooms have wide, uncarved baseboards, and carved reverse ogee molding. The walls and ceilings throughout the house are exposed beadboard except for the rear room on the east side. Currently called the conference room, this room has plastered walls, corner Gothic millwork and a picture rail.

Overall, the Foxx-Cox House is an excellent example of a rural Queen Anne house. Even though the house has undergone alterations and its function has changed, its location, materials, feel, and dimensions have remained intact thus qualifying it for National Register listing.

8. Statement of Significance

Applicable National Register Criteria

Areas of Significance

- A** Property is associated with events that have made a significant contribution to the broad patterns of our history.
- B** Property is associated with the lives of persons significant in our past.
- C** Property embodies the distinctive characteristics of a type, period, or method of construction or represents the work of a master, or possesses high artistic values, or represents a significant and distinguishable entity whose components lack individual distinction.
- D** Property has yielded, or is likely to yield information important in prehistory or history.

ARCHITECTURE

Period of Significance
c.1895

Significant Dates
c.1895

Criteria Considerations:

Property is:

- A** owned by a religious institution or used for religious purposes.
- B** removed from its original location.
- C** a birthplace or a grave.
- D** a cemetery.
- E** a reconstructed building, object, or structure.
- F** a commemorative property.
- G** less than 50 years of age or achieved significance within the past 50 years.

Significant Person(s)
N/A

Cultural Affiliation(s)
N/A

Architect/Builder
Unknown

Narrative Statement of Significance:

See continuation sheets.

9. Major Bibliographical References

Bibliography

See continuation sheet.

Previous documentation on file (NPS)

- preliminary determination of individual listing (36 CFR 67) has been requested.
- previously listed in the National Register
- previously determined eligible by the National Register
- designated a National Historic Landmark
- recorded by Historic American Buildings Survey

- recorded by Historic American Engineering Record

Primary Location of Additional Data

- State Historic Preservation Office
- Other State agency
- Federal agency
- Local government
- University
- Other

Name of repository:

MS Department of Archives and History

10. Geographical Data

Acreage of Property: less than one acre

UTM References:	Zone	Easting	Northing	Zone	Easting	Northing
A	15	741860	3480850	C		
B				D		

___ See continuation sheet.

Verbal Boundary Description See continuation sheet.

Boundary Justification: See continuation sheet.

11. Form Prepared By

name/title:	Jennifer Opager, Architectural Historian	date:	July 7, 1997
organization:	Mississippi Department of Archives and History	telephone:	601-359-6940
street & number:	P.O. Box 571	zip code:	39205
city or town:	Jackson	state:	MS

Additional Documentation

Submit the following items with the completed form:

Continuation Sheets

Maps

A USGS map (7.5 or 15 minute series) indicating the property's location.

A sketch map for historic districts and properties having large acreage or numerous resources.

Photographs

Representative black and white photographs of the property.

Additional items (Check with the SHPO or FPO for any additional items)

Property Owner(s)

name:	Mr. Bobby Moak	phone:	
street & number:	P.O. Box 242	state:	MS
city or town:	Bogue Chitto	zip code:	39629

Paperwork Reduction Act Statement: This information is being collected for applications to the National Register of Historic Places to nominate properties for listing or determine eligibility for listing, to list properties, and to amend existing listings. Response to this request is required to obtain a benefit in accordance with the National Historic Preservation Act, as amended (16 U.S.C. 470 et seq.).

Estimated Burden Statement: Public reporting burden for this form is estimated to average 18.1 hours per response including the time for reviewing instructions, gathering and maintaining data, and completing and reviewing the form. Direct comments regarding this burden estimate or any aspect of this form to the Chief, Administrative Services Division, National Park Service, P.O. Box 37127, Washington, DC 20013-7127; and the Office of Management and Budget, Paperwork Reductions Project (1024-0018), Washington, DC 20503.

United States Department of the Interior
National Park Service

**NATIONAL REGISTER OF HISTORIC PLACES
CONTINUATION SHEET**

Section: 8

Page: 4

Foxx-Cox House
Bogue Chitto, Lincoln Co., MS

STATEMENT OF SIGNIFICANCE

The Foxx-Cox House is significant under Criterion C for Architecture as an outstanding and intact local example of the Queen Anne style. The house, a one-story Queen Anne cottage, is the most ornate residence in the small rural town of Bogue Chitto. Several of Bogue Chitto's other houses dating from the same time period display the characteristics of the Folk Victorian style and are much less detailed than the Foxx-Cox House, which retains most of its identifying exterior and interior features, including imbricated shingling, cut-away bay windows, intricate spindle and scrollwork, fine beadboard, original mantelpieces, and an elaborate hall screen.

Because the Lincoln County Courthouse has been destroyed by fire on two occasions, the history of the Foxx-Cox House is rather murky. A construction date of circa 1890 or 1895 seems likely, based on the known growth spurt in Bogue Chitto with the establishment of two lumber mills nearby.¹ A late 19th century date is also suggested by the pitch of the roof, which is not at steep as the typical 1880s Queen Annes, but is not as shallow as the early 1900s examples.² The loss of courthouse documents has hampered efforts to date the construction of the Foxx-Cox House and to identify any other aspects of its history. Tradition states, however, that the original owner was an Illinois Central trainmaster named Foxx, and that the property was owned by the Cox family at some later date, possibly around the time of the 1930s rear addition.

The Queen Anne style was popular in Mississippi from around 1885 until about 1905 when the Colonial Revival and Neoclassical styles began to appear more frequently in the state. In Mississippi, the style was most often found in detached residences, with very few institutional or commercial examples. Queen Anne residences were usually popular with members of the new merchant class which rose to a leadership role in the New South during the late nineteenth century and which congregated in the growing railroad towns and cities of Mississippi.³

In Mississippi, the most common sub-types of the Queen Anne style were the Spindlework and the Free Classical modes. The Foxx-Cox House is an excellent example of the Spindlework design, with its turned porch supports, spindlework in the porch frieze area and under the cut-away bay window, and intricate

¹ Brieger, James F. *Hometown Mississippi*. p. 307.

² See McAlester, Virginia and Lee. *Field Guide to American Houses*. p. 267 for a pictorial description of the typical roof-pitch chronology from ca. 1885 to 1905 and after.

³ Cawthon, Richard J. *Victorian Queen Anne Architecture in Mississippi*. p. 6.

United States Department of the Interior
National Park Service

**NATIONAL REGISTER OF HISTORIC PLACES
CONTINUATION SHEET**

Section: 8, 9, 10

Page: 5

Foxx-Cox House
Bogue Chitto, Lincoln Co., MS

gable ornamentation. As such, the house compares favorably to the Galloway-Williams House, a Spindlework Queen Anne cottage in Jackson, Hinds County (listed NR 10/10/85).

Although minor alterations have occurred, including a historic rear addition, the Foxx-Cox House retains most of its identifying exterior and interior features--delicate turned porch supports, intricate spindlework, imbricated shingles, original carved mantelpieces and hall screen, beadboard ceilings and walls, and door and window surrounds with corner block paterae. Thus, the Foxx-Cox House is locally significant under Criterion C as an intact example of a Spindlework Queen Anne cottage.

BIBLIOGRAPHY

Brieger, James F. *Hometown Mississippi*. 1980.

Cawthon, Richard J. "Victorian Queen Anne Architecture in Mississippi." Unpublished context report on file at the Division of Historic Preservation, Mississippi Department of Archives and History, Jackson, MS.

Lincoln County Deed Book 769, pp.115-118. Brookhaven, Lincoln County Courthouse, Records Office.

McAlester, Virginia and Lee. *A Field Guide to American Houses*. New York: Alfred A. Knopf, 1993.

GEOGRAPHICAL DATA

Boundary Description: The boundary of the Foxx-Cox property is illustrated on the attached map and is legally described as follows:

"A parcel of land being situated in Block 14 of the J.A. Porter survey of the town of Bogue Chitto, and in the SW 1/4 of Section 36, Township 6 North, Range 7 East, Lincoln County, Mississippi, and being more particularly described as follows: From the Se corner of said SW 1/4 of Section 36, Township 6 North, Range 7 East run North a distance of 594.3 feet along the west boundary of Morgan Street to the point of beginning:

1. Thence North 120.0 feet along the west boundary of Morgan Street;

United States Department of the Interior
National Park Service

**NATIONAL REGISTER OF HISTORIC PLACES
CONTINUATION SHEET**

Section: 8, 9, 10

Page: 6

Foxx-Cox House
Bogue Chitto, Lincoln Co., MS

2. Thence North 81 degrees 56 minutes West 140.0 feet along the south edge of a concrete sidewalk on the south side of Monticello Street;
3. Thence South 120.0 feet;
4. Thence South 81 degrees 56 minutes East 140.0 feet to the point of beginning.⁴

Boundary Justification: The boundary has been chosen to include the property historically associated with the Foxx-Cox House.

⁴ Both the legal description and the scaled map can be found in Lincoln County DB 769, pp.115-118.

FOXX-COXX HOUSE

Bogue Chitto, Lincoln County, Mississippi

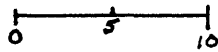
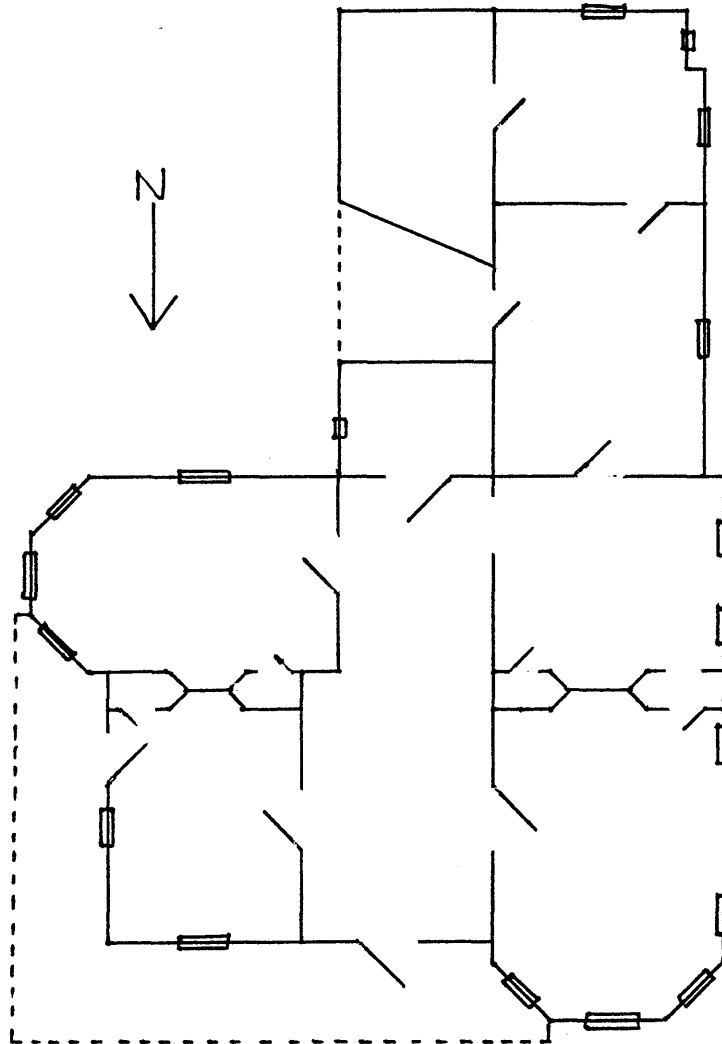

1 inch = 10 ft.

ROBERT W. MOAK

PARCEL IN BLOCK 14, OF THE J.A. PORTER SURVEY OF THE TOWN OF BOGUE CHITTO, IN SECTION 36, T 6 N R 7 E, LINCOLN COUNTY, MISS.

BOOK 769 PAGE 118

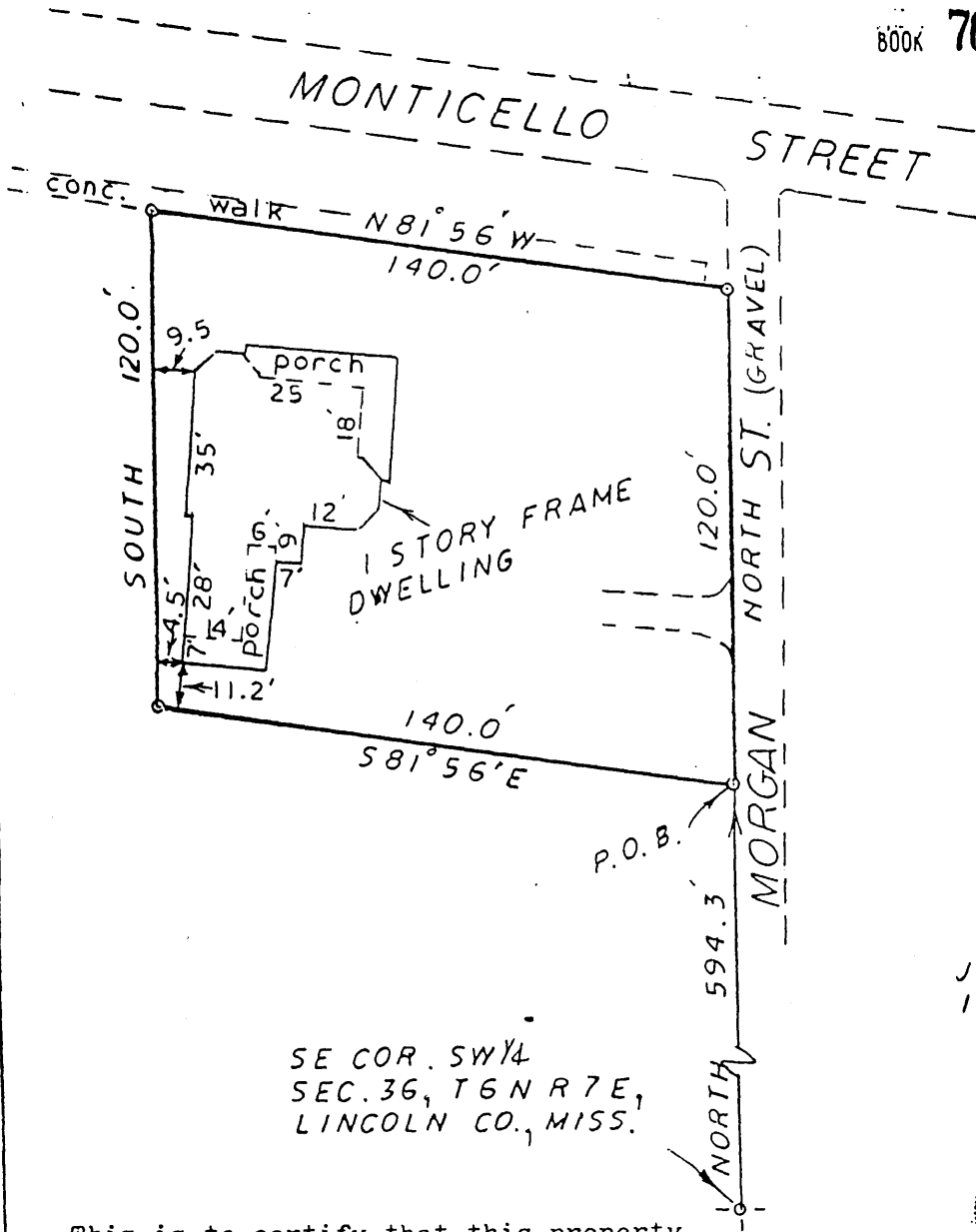

JUNE 13, 1985
1" = 40'

SE COR. SW 1/4
SEC. 36, T 6 N R 7 E,
LINCOLN CO., MISS.

This is to certify that this property is not in a flood hazard zone.

Robert W. Moak



STATE OF MISSISSIPPI, COUNTY OF LINCOLN:

Chancery Clerk

I certify that this instrument was filed for record in my office at 9:00 o'clock A.M. on the 9 day of July 1985, and was duly recorded on the 9 day of July 1985. Book 769 Page 115

Witness my hand and seal this 12 day of July 1985.

J. RONNY SMITH, Chancery Clerk
By *Loren Nettles*, D.C.

