

United States Department of the Interior  
National Park Service

National Register of Historic Places  
Continuation Sheet

_____
Name of Property
_____
County and State
_____
Name of multiple listing (if applicable)

Section number \_\_\_\_\_ Page \_\_\_\_\_ 1 \_\_\_\_\_

Supplementary Listing Record

NRIS Reference Number: SG100002216

Date Listed: 3/15/2018

Property Name: Enid High School Observatory

County: Garfield

State: OK

This Property is listed in the National Register of Historic Places in accordance with the attached nomination documentation subject to the following exceptions, exclusions, or amendments, notwithstanding the National Park Service certification included in the nomination documentation



Signature of the Keeper

3/15/2018

Date of Action

Amended Items in Nomination:

**Geographical References:**

The *Verbal Boundary Description* is revised to fully incorporate the footprint of the 2005 Food Court and 2013 University Center additions into the nominated boundary. Boundary lines cannot be drawn through interconnected buildings and the Food Court is clearly an addition with multiple through connections to the historic school buildings. For purposes of this nomination, the Food Court and University Center are considered non-historic elements of the nominated building complex, dating from outside the period of significance and having no direct association with the significant themes outlined in the nomination. (See revised Map 5)

The Latitude and Longitude Coordinates should read: 36.388200 -97.886300 (as noted correctly on Map 1; rather than the typographical error noted on page 9-29.)

The OKLAHOMA SHPO was notified of this amendment.

**DISTRIBUTION:**

- National Register property file
- Nominating Authority (without nomination attachment)

United States Department of the Interior  
National Park Service

National Register of Historic Places  
Continuation Sheet

Enid High School Observatory
Name of Property
Garfield County, Oklahoma
County and State
Name of multiple listing (if applicable)

Section number MAP Page 5

Map 5: Current site plan of permanent buildings on the Enid High School campus (excludes temporary classroom buildings, athletic fields, and parking lots). Area outline with heavy black lines depicts the boundaries of the nominated resource. Courtesy Enid Public Schools.

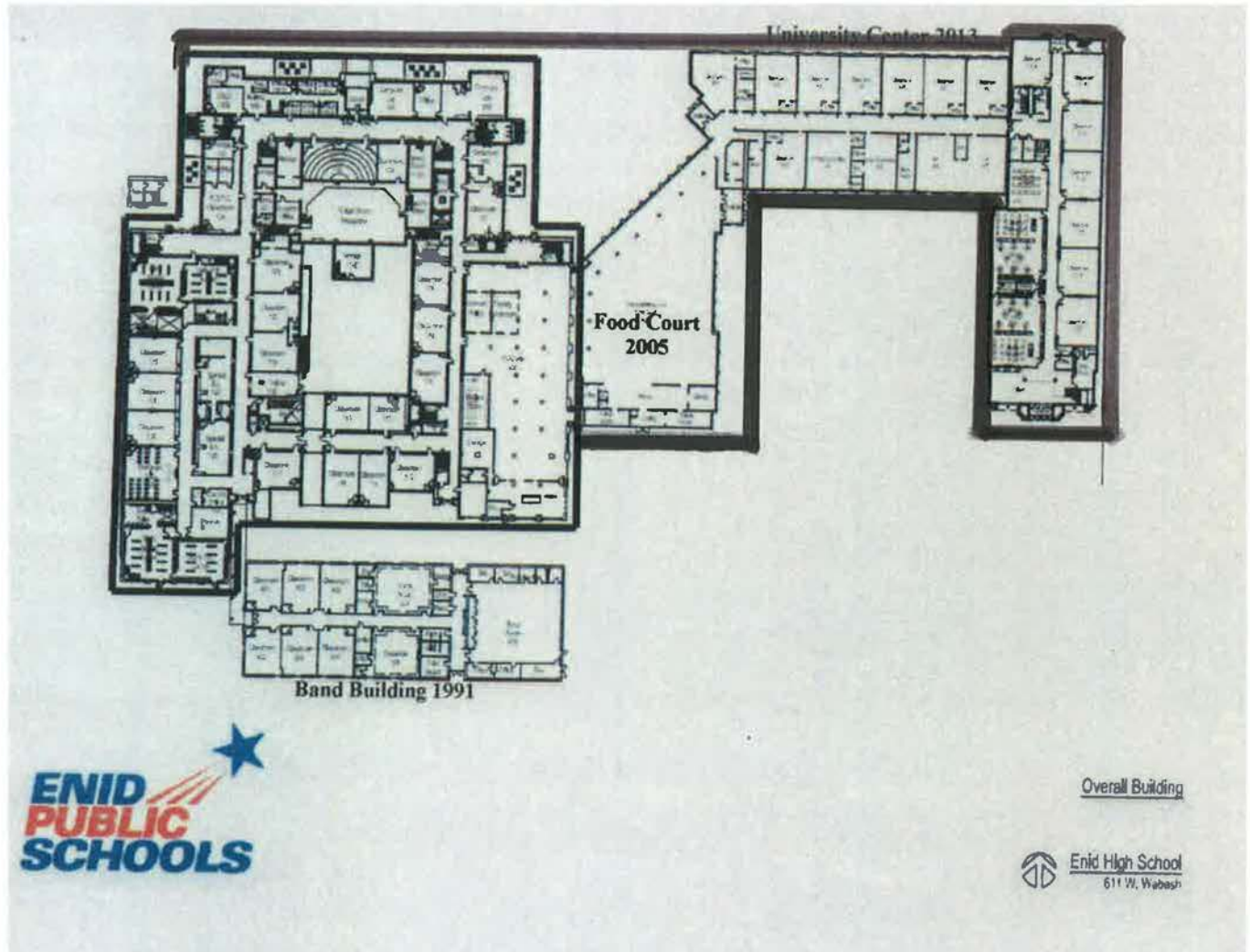



SG 2216

United States Department of the Interior  
National Park Service

# National Register of Historic Places Registration Form

This form is for use in nominating or requesting determinations for individual properties and districts. See instructions in National Register Bulletin, *How to Complete the National Register of Historic Places Registration Form*. If any item does not apply to the property being documented, enter "N/A" for "not applicable." For functions, architectural classification, materials, and areas of significance, enter only categories and subcategories from the instructions.

### 1. Name of Property

Historic name: Enid High School Observatory

Other names/site number: Dr. Nancy Currie-Gregg Observatory

Name of related multiple property listing:

N/A

(Enter "N/A" if property is not part of a multiple property listing)

### 2. Location

Street & number: 611 W. Wabash Avenue

City or town: Enid State: Oklahoma County: Garfield

Not For Publication:  N/A

Vicinity:  N/A

### 3. State/Federal Agency Certification

As the designated authority under the National Historic Preservation Act, as amended,



I hereby certify that this X nomination     request for determination of eligibility meets the documentation standards for registering properties in the National Register of Historic Places and meets the procedural and professional requirements set forth in 36 CFR Part 60.

In my opinion, the property X meets     does not meet the National Register Criteria. I recommend that this property be considered significant at the following level(s) of significance:

    national     X statewide     local

Applicable National Register Criteria:

X A     B     C     D

 <b>Signature of certifying official/Title:</b>	 <b>Date</b>
<b>State or Federal agency/bureau or Tribal Government</b>	

In my opinion, the property <u>   </u> meets <u>   </u> does not meet the National Register criteria.	
<b>Signature of commenting official:</b>	<b>Date</b>
<b>Title :</b>	
<b>State or Federal agency/bureau or Tribal Government</b>	

Enid High School Observatory  
Name of Property

Garfield County, Oklahoma  
County and State

**4. National Park Service Certification**

I hereby certify that this property is:

- entered in the National Register
- determined eligible for the National Register
- determined not eligible for the National Register
- removed from the National Register
- other (explain:)

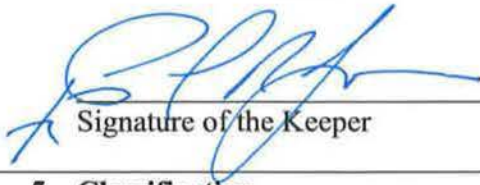
  
Signature of the Keeper

3/15/2018  
Date of Action

**5. Classification**

**Ownership of Property**

(Check as many boxes as apply.)

- Private:
- Public – Local
- Public – State
- Public – Federal

**Category of Property**

(Check only one box.)

- Building(s)
- District
- Site
- Structure
- Object



Enid High School Observatory  
Name of Property

Garfield County, Oklahoma  
County and State

**Number of Resources within Property**

(Do not include previously listed resources in the count)

Contributing	Noncontributing	
<u>1</u>	<u>0</u>	buildings
<u>0</u>	<u>0</u>	sites
<u>0</u>	<u>0</u>	structures
<u>0</u>	<u>0</u>	objects
<u>1</u>	<u>0</u>	Total

Number of contributing resources previously listed in the National Register 0

---

**6. Function or Use**

**Historic Functions**

(Enter categories from instructions.)

Education: research facility/observatory  
\_\_\_\_\_  
\_\_\_\_\_  
\_\_\_\_\_  
\_\_\_\_\_  
\_\_\_\_\_

**Current Functions**

(Enter categories from instructions.)

Education: research facility/observatory  
\_\_\_\_\_  
\_\_\_\_\_  
\_\_\_\_\_  
\_\_\_\_\_  
\_\_\_\_\_

Enid High School Observatory  
Name of Property

Garfield County, Oklahoma  
County and State

---

## 7. Description

### Architectural Classification

(Enter categories from instructions.)

Other: Observatory  
Collegiate Gothic

---

---

---

---

---

**Materials:** (enter categories from instructions.)

Principal exterior materials of the property: Steel, concrete block, brick

### Narrative Description

(Describe the historic and current physical appearance and condition of the property. Describe contributing and noncontributing resources if applicable. Begin with a **summary paragraph** that briefly describes the general characteristics of the property, such as its location, type, style, method of construction, setting, size, and significant features. Indicate whether the property has historic integrity.)

---

### Summary Paragraph

The Enid High School Observatory sits atop the west side of the roof of Enid High School at 611 W. Wabash Avenue, in Enid, Garfield County, Oklahoma, approximately .7 miles southwest of the heart of the city's central business district. It is composed of a steel-sided semi-spherical dome that has an interior diameter of sixteen feet and an exterior diameter of approximately eighteen feet. Two shutters slide open horizontally at the viewing aperture. A 7-foot high circular concrete block base with a steel-frame door on its north side supports the dome. An elevated concrete platform inside the observatory supports a telescope and acts as a viewing structure. The observatory was installed on the deck of the school's roof in 1963 and is visible from the west lawn. The three-story red brick school building upon which the observatory sits was constructed in 1911-1912 in the Collegiate Gothic style. A series of sympathetic additions between 1920 and 1965 give the building its current irregular rectangular configuration. The school sits on a six-block campus that includes a music building (1991), an athletic field, portable classrooms, parking lots, and two classroom additions constructed in 2005 and 2013. These features are excluded from this nomination and the nominated resource includes only the footprint of the 1912-1965 high

Enid High School Observatory  
Name of Property

Garfield County, Oklahoma  
County and State

school building. Although alterations to the building's windows have negatively impacted its integrity they do not detract from the observatory's ability to represent its significance as a manifestation of reforms in science education as a result of the passage of the National Defense Education Act in 1958. The Enid High School Observatory retains excellent integrity and is the significant feature of the nominated resource.

---

## **Narrative Description**

### **Setting:**

Enid High School is located approximately .7 mile southwest of the Garfield County Courthouse and just south of the sprawling Integris Bass Baptist Health Center complex. It is two blocks south of West Owen K. Garriott Road (U.S. Hwy 64) and three blocks east of South Van Buren Street (U.S. Hwy 81), two busy highways that together with the city's railroad network contributed to Enid's status as an agricultural center in north central Oklahoma.

Prior to the construction of the Enid High School (EHS) Observatory in 1963, the school's campus encompassed approximately three city blocks (see Figure 3). The campus was bordered on the north by West Wabash Avenue, South Monroe Street on the west, West Illinois Avenue on the south, and South Madison Street on the east. The three-story high school faces north towards West Wabash Avenue. South of the school is a track and athletic field. The Margaret Buvinger Music Building, located between the school building and the athletic field, was dedicated in 1991. The campus has expanded east to South Jefferson Street and now includes approximately six city blocks. In 2004-2005, an addition of ten-classrooms and a food court was constructed on the east side of the building's auditorium wing, and in 2013, University Center was constructed to its east on the block bordered by West Wabash, South Madison, West York Avenue, and South Jefferson Street. Here students take Advanced Placement Courses for which they receive high school and college credit. These features are excluded from the boundaries of the nominated resource (See Map ).

Paralleling Wabash Avenue and Madison Street and framing the high school building on the north and south are concrete sidewalks with curbs on their inside edges. Mature and smaller trees partially obscure the north elevation. Directly in front of the façade's main entrance is a sculpture by Harold T. Holden, a 1958 alumnus of the school, titled "Vision Seeker." The bronze sculpture is of a male Native American sitting cross-legged holding his chin with his right hand. On his head is a feathered headdress. It sits on a red granite base. The sculpture is a representation of the school's mascot, the Plainsman, and was a gift of the Champlin Family in memory of Joe N. and Jane E. Champlin. It was dedicated October 14, 1998. North of the school's northwest corner is the Millennium Fountain, a tiered fountain sitting on a base of four Solomonic columns. Surrounding the fountain is a round pool. The fountain was a gift of EHS Senior Class of 1950 and designed by William Dow Gumerson. Surrounding the fountain is a brick and concrete plaza and



Enid High School Observatory  
Name of Property

Garfield County, Oklahoma  
County and State

nearby is a red brick and cast stone monument sign bearing the school's name. These features are also excluded from the boundaries of the nominated resource.

Surrounding the high school campus is a residential neighborhood laid out in a traditional grid pattern. The housing stock dates from the early twentieth century to the World War II-era and primarily consists of modest one-story wood-framed bungalows and massed-planned and gable-front folk style houses. Expansion of the nearby medical district to the north and the high school's campus has resulted in the removal of dwellings formerly in those areas.

## **Enid High School**

### Exterior

Enid High School is a three-story, red brick building with an irregular-rectangular massing. Its form and ornamentation reflect the Collegiate Gothic style. As the name suggests, the style was popular for educational buildings constructed during the first three decades of the twentieth century. White limestone water tables skirt the foundation. Between the water table and the top of the first floor windows, the brick is laid with every sixth row recessed, providing horizontal banding around the base of the building. In addition to the water table, decorative details in white or cast stone provide a rich contrast to the red brick walls. The building was initially constructed in 1911-1912 [the date 1912 is mostly used in the nomination] and expanded over the next fifty-three years with the addition of gymnasium and auditorium wings on the west and east sides, respectively, and classroom additions to the rear. Historically, the building contained ribbons of multiple-light double hung windows in large window openings. The openings have been mostly infilled with polychrome gray tile, leaving a vertical slit of six-paned windows of smoked glass at the center of the opening.

The façade (north elevation) has a symmetrical arrangement and is divided into seven bays. The outer and center bays project slightly from the other four bays. Shaped parapets with stone coping are located above these bays and between the second and third, and fifth and sixth bays. Below all of the shaped parapets, except for the center bay, is a framed box of brick laid in a diaper pattern. Below the frame is a stone wedge-shaped panel with decorative scrollwork. The center bay contains the entrance. The entrance is elevated between the first and second floors and accessed by stone stairs that are flanked by knee walls. White limestone sheaths the wall surface around the entrance which is accessed through a Tudor arch. The entrance contains non-original paired smoked-glass doors and wide sidelights and transoms. A white stone band above the arch bears the words "High School" in a Gothic-inspired font. Above this band and set within the brick wall is a white stone block with the date 1911, also written in a Gothic-inspired font. At the third floor level of this bay is a boxed bay window embellished with details such as strapwork. Within the box are three 1/1 metal-framed windows of smoked glass with smoked glass clerestories above. Above the bay's lintel is an ornamented rectangular cartouche with a book in its center. Quoins decorate the corners of the box bay and frame the bay window. The large window openings have been infilled with gray tiles and the six-paned smoked glass windows in the center. The end bays have no windows except one on the first floor (Photo 1).

Enid High School Observatory  
Name of Property

Garfield County, Oklahoma  
County and State

The east elevation is divided into two distinct parts. The north portion is the original east elevation of the 1912 building. It shares details similar to those on the north elevation including a shaped parapet and white limestone ornamentation. A one-story portal with Collegiate Gothic details contains the entrance which is approached by stairs flanked by knee walls. The smoked glass doors and surrounding glass are not original. The words "High School" are inscribed along the portal's parapet. Most window openings have been infilled with gray tile and metal-framed smoked glass windows. The southern portion of this elevation is the auditorium wing. It was added in 1955 and projects forward from the 1912 portion of the building. Although constructed four decades later, it also contains white stone ornamentation and shaped parapets that pick up on the Collegiate Gothic style. The entrance to the auditorium is at grade level. Its surrounding portal is constructed of white stone. Below its parapet is written "Auditorium." Because this is the auditorium wing, there are few window openings but those that exist have also been infilled with gray tile and smoked glass windows. The east and south elevations have brick pilasters that provide a vertical rhythm (Photo 2).

The west elevation is also divided into two distinct parts; the north portion is the 1912 building and the southern portion is the projecting gymnasium wing which was added in 1950-1951. Both portions have entrances similar to those on the respective portions of the east elevation. The west elevation of the gymnasium formerly had very large window openings above the first floor. These have been completely infilled with the gray tile used elsewhere on the building. First floor windows are either partially or completely infilled with the gray tile. The gymnasium's west and south elevations have brick pilaster that provide a vertical rhythm (Photo 3).

The rear elevation is more utilitarian in appearance although it has some white trim. It has an irregular massing due to the various additions and programmatic functions. Those portions containing classrooms (added in the 1960s) have had the window openings infilled with gray tile and smoked glass windows like those on other elevations. There is a roll-up garage door near the center of this elevation (Photo 4).

### Interior

The interior of EHS has been modified over the years as the result of additions and a fire in 1943 that resulted in the school's closure for a few years. The original building had light wells flanking the auditorium that was located in the center of the second and third floors. The auditorium was relocated to a subsequent addition and the space infilled with classrooms on both floors. The light wells were retained. The most recent alterations were made in 2012 and include new wood finishes on pilasters and columns and the addition of new ceiling fixtures in the front (north) corridor of the second floor. However, the building's circulation system of double-loaded corridors mostly remains as do many of the classrooms' wood-framed multiple-light transoms, doors, and interior windows. The historic geometrically-patterned metal balustrades at the northwest and northeast stairwells remain as does the historic white marble in the front (north) vestibule. A brief description of each floor follows.

Enid High School Observatory  
Name of Property

Garfield County, Oklahoma  
County and State

The ground floor contains classrooms, offices, computer labs, and a lecture room. The gymnasium space from the 1912 building now serves as a weight room. In the east (auditorium) wing is the cafeteria and spaces devoted to an office for campus police, faculty lunchroom, student store, and storage. In the west (gymnasium) wing are regular classrooms, classrooms for special education, and boys' and girls' physical education lockers, school lockers, and toilets. There is an open courtyard between the 1912 building, the east and west wings, and the rear addition. The second floor contains the school's administrative and principal's offices and other office spaces across the north side of the north corridor. When the 1912 building was constructed, there was an auditorium on the south side of the north corridor that comprised the center section of this floor. This space now serves as the library. The original light wells are located along the east and west sides of the library and extend to the third floor. The east wing is largely composed of the auditorium and stage and has a two-story volume. The west wing is divided into two gymnasiums with a two-story volume. The rear (south) additions are divided into classroom spaces. The space between the 1912 building, the east and west wings, and the rear additions is open to the courtyard below. The third floor contains numerous classrooms. What was formerly the balcony area of the 1912 building's auditorium has been infilled with rooms that host physics and chemistry classes. Flanking these rooms are the light wells. The third floor of the east (auditorium) wing provides access to the balcony and the stage's fly loft. The rear additions contain classroom spaces. The center of the third floor is open to the courtyard.

### **Enid High School Observatory**

The Enid High School observatory is located near the west edge of the high school building's roof near the juncture of the 1912 building and the 1950-1951 gymnasium addition. Although on the roof, the observatory is readily visible from the ground (Photo 3). The roof is accessed by stairs at the intersection of the north and west corridors on the third floor. The stairs lead to a red brick headhouse/room on the roof (Photo 5). It has windows on its south elevation. A door on the west elevation of the room provides access to the roof which is covered with a wood deck that extends west to the building's parapet. The deck is surrounded by a chain link fence as a safety barrier. There is an opening in the south side of the fence for a wood walkway that leads to the door of the observatory. The walkway also is lined on its west and east sides by a chain link fence.

The steel door to the observatory is located on the north side of the circular base of the dome. There are no other windows or doors in the base. The 7-foot high base is constructed of concrete block and its exterior is covered with a moisture barrier. On top of the base is the observatory's semi-spherical steel dome that is roughly circular in plan. It has a 16-foot interior diameter and an outside diameter of approximately 18 feet. Mounted on one side of the dome are two longitudinally curved shutters that are shaped to conform to the contour of the semi-spherical dome. The shutter's curved frame members are affixed to the dome. The shutters are manually operated through a 6-to-1 torque converter located in the interior near the base of the dome. The shutters slide horizontally toward and away from each other to reveal or cover the vertical opening used for sighting a telescope. The opening extends from the base of the dome to a point beyond the top



Enid High School Observatory  
Name of Property

Garfield County, Oklahoma  
County and State

center of the dome. The dome revolves around the concrete block circular base on weight-bearing rollers in contact with a track rail channel attached to the inner perimeter of the concrete base. A push button mechanism operates the electric motor that powers the dome as it rotates (Photos 6 and 7).

Inside, the dome is self-supporting with no columns or braces obscuring its span. The base's interior concrete block wall is unpainted. The floor inside the observatory is concrete. At its center is a concrete pier that supports the deck of the viewing platform. The platform is also supported by slender steel columns. On the east and west side of the platform are open steel stairs with a vertical curve that lead to the viewing deck. The perimeter of the viewing deck is surrounded by a steel railing supported by simple steel posts (this is a recent addition, replacing chains hung between low supports). The surface of the deck is of textured galvanized steel (Photos 8 and 9).

Mounted at the center of the viewing platform is a Tinsley 8-inch f/16 Cassegrain telescope. It was installed in 1965 (Photos 8 and 10).

Considering its exposure to the elements for the past 55 years, the observatory is in remarkably good shape. Small amounts of rust are evident on the dome's exterior and interior. The gray paint on the dome's exterior has worn away in some areas. The dome easily rotates on its rollers and the shutters are still operational. The observatory is still used for astronomy classes at EHS. Approximately 400 students are currently enrolled in those classes.

The Enid High School Observatory retains the seven aspects of integrity to a high degree. It retains its integrity of location and setting as it is still sited on the west edge of EHS's roof. It retains the key aspects of materials, design, and workmanship as it has received no alterations or modifications other than routine maintenance and repairs. It continues to possess the character-defining features of the concrete block circular base, the steel-sided semi-spherical dome, the viewing aperture, and the horizontally curved shutters that expose or cover the aperture. Retention of these features contributes to the integrity aspect of feeling. Because it is still being used for its original function, the Enid High School Observatory retains its integrity of association.

Enid High School Observatory  
Name of Property

Garfield County, Oklahoma  
County and State

## 8. Statement of Significance

### Applicable National Register Criteria

(Mark "x" in one or more boxes for the criteria qualifying the property for National Register listing.)

- A. Property is associated with events that have made a significant contribution to the broad patterns of our history.
- B. Property is associated with the lives of persons significant in our past.
- C. Property embodies the distinctive characteristics of a type, period, or method of construction or represents the work of a master, or possesses high artistic values, or represents a significant and distinguishable entity whose components lack individual distinction.
- D. Property has yielded, or is likely to yield, information important in prehistory or history.

### Criteria Considerations

(Mark "x" in all the boxes that apply.)

- A. Owned by a religious institution or used for religious purposes
- B. Removed from its original location
- C. A birthplace or grave
- D. A cemetery
- E. A reconstructed building, object, or structure
- F. A commemorative property
- G. Less than 50 years old or achieving significance within the past 50 years

Enid High School Observatory  
Name of Property

Garfield County, Oklahoma  
County and State

**Areas of Significance**

(Enter categories from instructions.)

Education  
\_\_\_\_\_  
\_\_\_\_\_  
\_\_\_\_\_  
\_\_\_\_\_  
\_\_\_\_\_  
\_\_\_\_\_

**Period of Significance**

1963-1968  
\_\_\_\_\_  
\_\_\_\_\_

**Significant Dates**

1963  
1965  
\_\_\_\_\_

**Significant Person**

(Complete only if Criterion B is marked above.)

N/A  
\_\_\_\_\_  
\_\_\_\_\_

**Cultural Affiliation**

N/A  
\_\_\_\_\_  
\_\_\_\_\_

**Architect/Builder**

Shaw, R. W.  
P. C. Davis & Sons Construction  
Wheeler and Wheeler  
Astro-Dome, Inc.



Enid High School Observatory  
Name of Property

Garfield County, Oklahoma  
County and State

**Statement of Significance Summary Paragraph** (Provide a summary paragraph that includes level of significance, applicable criteria, justification for the period of significance, and any applicable criteria considerations.)

The Enid High School Observatory in Enid, Oklahoma is eligible for listing in the National Register of Historic Places at the state level of significance under Criterion A in the area of Education. Located on the roof of Enid High School, the observatory, with its semi-spherical steel dome, is significant for its association with the National Defense Education Act of 1958 and attempts to improve the quality of science education in public schools in the post-Sputnik era. The period of significance begins in 1963, the year the observatory was constructed, and ends in 1968. The latter year recognizes the continued use of the observatory as an aid to astronomy education at the high school and corresponds to the National Register's 50-year guideline. During the period of significance, the Enid High School Observatory was the only high school observatory in the state and remains so to this date.

---

**Narrative Statement of Significance** (Provide at least **one** paragraph for each area of significance.)

### **Historic Context**

#### *Enid's Early Growth*

Enid is located in north central Oklahoma in what historically was the Cherokee Outlet, an area of seven million acres acquired by the Cherokees upon their forced removal from their homelands in the southeastern United States to Indian Territory in the 1830s. In the 1860s and 1870s, the Cherokee leased land in the Outlet to Texas cattlemen. What became the town of Enid was sited at the location of a natural spring along the Chisholm Trail, the famous cattle trail that stretched from southern Texas to railheads in Kansas. In anticipation of the opening of the Outlet to non-Native settlement on September 16, 1893, Enid's original 320-acre town site was platted in lots and blocks in a traditional grid pattern around a courthouse square with the hopes of avoiding the land disputes that plagued Oklahoma City and Guthrie when the Unassigned Lands were opened to settlement in 1889, although that was not to be the case. Eager land-seekers flooded the town site and it was estimated that Enid had a population of 15,000 six hours after the opening. However, by 1896 its population had decreased to approximately 1,250. The population rebounded and by 1900 it had approximately 3,444 residents and by 1910, it had grown dramatically to 13,799. Its expanding rail service contributed to the city's status as Oklahoma's grain capital and one of the largest grain centers in the country. With the discovery of oil in the nearby Garber-Covington oil field in 1916 and the resulting oil boom, Enid became an important petroleum center in Oklahoma and one of the wealthiest towns in the state. Further growth came in the World War II-era with the

Enid High School Observatory  
Name of Property

Garfield County, Oklahoma  
County and State

location of what became known as Vance Air Force Base on the city's southern edge. By 1970, Enid had a population of 44,986.<sup>1</sup>

One of the important factors of successful town building was the establishment of a system of public education. The first school in Enid started as a subscription school housed in a tent. Enid's public schools were founded in 1894. Early records indicate that the first high school was located in a Baptist Church and then operated in various locations. The first record of high school graduates occurred in 1898 when two students completed their high school studies. Its first permanent high school building for whites, a three-story brick structure, was constructed in 1906 on North Independence. Enid schools remained segregated until the 1959-1960 school year when they were integrated.<sup>2</sup>

### Construction of Enid High School

As mentioned, Enid's population increased dramatically between 1900 and 1910, from 3,444 residents to 13,799. The high school constructed in 1906 could not accommodate the corresponding increase in students. In February 1911, the *Enid Daily Eagle* published a rendering of the proposed new high school to be constructed on West Wabash Avenue southwest of the city's downtown (Figure 1). Designed by Enid architect R. W. Shaw, the three-story brick building featured a symmetrical façade and white stone embellishments associated with the Collegiate Gothic style. Advertisements for construction bids appeared later in the month and in late March, the contract was awarded to Wuster Construction Company of Wichita, Kansas. Although the building's cornerstone and a date block above the main entrance suggest it was completed in 1911, it was not completed until 1912.<sup>3</sup>

Shaw's design for the building represented the latest in school design and when completed, it received national attention. It was featured in the July issue of the *American School Board Journal* and then a photograph of the building and its floor plans appeared in the book *High School Buildings* released by the same publication in 1913 (Figure 2).<sup>4</sup> The double-loaded corridors on all floors had a squared-C configuration. The first (ground) floor contained classroom space as well as recreational and programmatic spaces. The east wing was devoted to domestic science and sewing for girls. The west wing contained industrial training rooms (forge, moulding) for boys.

---

<sup>1</sup> Gary L. Brown, "Enid." *The Encyclopedia of Oklahoma History and Culture*, [www.okhistory.org](http://www.okhistory.org). (accessed July 13, 2017); Alvin O. Turner, "Cherokee Outlet Opening," *The Encyclopedia of Oklahoma History and Culture*, [www.okhistory.org](http://www.okhistory.org) (accessed September 14, 2017); John W. Morris, *Cities of Oklahoma*, book, 1979; Oklahoma City, Oklahoma ([gateway.okhistory.org/ark:/67531/metadc862904/m1/53/?q=enid](http://gateway.okhistory.org/ark:/67531/metadc862904/m1/53/?q=enid)) accessed July 28, 2017, *The Gateway to Oklahoma History*, [gateway.okhistory.org](http://gateway.okhistory.org). [pp. 8, and 43-44]; Glen V. McIntyre, *Enid: 1893-1945* (Charleston, South Carolina, 2012), p. 23.

<sup>2</sup> Gary L. Brown, compiler, "History of Enid High School," *EnidHistory.org, LLC*, [www.brownlaw-ok.com/enidhistory/articles/enidhigh.pdf](http://www.brownlaw-ok.com/enidhistory/articles/enidhigh.pdf) (accessed July 13, 2017), p. 1; McIntyre, *Enid: 1893-1945*, pp. 65 and 69; Hardy-Heck-Moore & Associates, Inc., "Historic Resources Survey of the Southern Heights/East Park Project Area, Enid, Oklahoma," October, 1997, p. 77.

<sup>3</sup> *Enid Daily Eagle*, February 5, 1911, February 21, 1911, and March 23, 1911; Brown, "History of Enid High School," p. 1.

<sup>4</sup> Bruce, *High School Buildings*, pp. 82-84. Oklahoma City's Central High School also appeared in the book.

Enid High School Observatory  
Name of Property

Garfield County, Oklahoma  
County and State

Across the north side were the kitchen, lunch room, bench and lathe room, and a mechanical drawing room. The center rear of the floor contained the gymnasium flanked by locker rooms and boys and girls toilet and bath (shower) rooms. At the southwest corner was the boiler room and a below ground coal room. The second floor's west and east wings each had three classrooms and locker and toilet rooms. Across the north side of the floor were offices and a combined library and study hall. The center portion of the floor was devoted to the auditorium. Flanking the auditorium on its east and west sides were light wells that provided needed illumination and ventilation to adjacent spaces. The third floor was mostly devoted to the sciences (physiography, biology, chemistry, and physics), Latin, a printing office, and a "society hall." The center of the floor provided access to the auditorium's balcony. Light wells also provided for illumination and ventilation.<sup>5</sup>

Increased enrollment from students in Enid and surrounding areas resulted in the construction of a 64 x 125-foot brick and reinforced concrete addition off of the building's southeast corner in 1919-1920 (Map 4). This addition consisted of twelve classrooms and a cafeteria. The architect of the original building, R. W. Shaw, also designed the addition, estimated to cost \$100,000.<sup>6</sup>

In September 1943, the high school building was nearly destroyed by fire. Wartime shortages prevented the school from being rebuilt and high school classes were held in Longmire and Emerson junior high schools. Work on repairing the building began in 1947 according to plans developed by R. W. Shaw. After Shaw's death on October 2, 1947, the task of overseeing the building's completion was assigned to M. N. (Marion Norris) Wheeler, Shaw's associate. When students moved into the building on March 9, 1948, school officials referred to the building as the "new" Enid High School even though the footprint and exterior walls were retained.<sup>7</sup>

Over the next twelve years, Enid High School (EHS) was enlarged to its current footprint. A gymnasium wing was added at the west end of the rear of the building and was placed into service during the second semester of the 1950-1951 school year. Its brick walls and decorative trim were compatible to the 1912 portion of the building (see Figure 3). An auditorium was dedicated on March 8, 1955. It was constructed along the east elevation, giving the building balanced proportions with projecting wings on both sides. Its exterior also was complementary to the historic features of the original portion of the school. In 1961, a nine-classroom addition was constructed at the rear of the building and another six classrooms were added in 1965. The placement of the rear addition created an enclosed courtyard between the 1912 building and its additions.<sup>8</sup>

---

<sup>5</sup> This description is based on floor plans of the building that appeared in *High School Buildings*, William C. Bruce, compiler (Milwaukee, Wisconsin: The American School Board Journal, 1913), pp. 83-84. A detailed description of the school also appeared in *American School Board Journal* in July 1925 according to *A Bibliography of School Buildings, Grounds, and Equipment* by Henry Lester Smith and Leo Martin Chamberlain (Bloomington, Indiana: Bureau of Cooperative Research, Indiana University [1928-45]), p. 289.

<sup>6</sup> *The American Architect*, 115 (March 26, 1919, Number 2257): 20; Brown, "History of Enid High School," p. 1.

<sup>7</sup> "Enid Opening New School," *Daily Oklahoman*, April 18, 1948.

<sup>8</sup> Brown, "History of Enid High School," pp. 1-2.



Enid High School Observatory  
Name of Property

Garfield County, Oklahoma  
County and State

The building has since undergone several additions and interior alterations. In 2004-05, a wing containing ten classrooms and food court was constructed to the east of the auditorium. Its angular design broke with the Collegiate Gothic motifs of the earlier building and its additions. Interior alterations to the 1912-1965 building occurred in 2011-2012 with renovations to the auditorium and library, conversion of two classrooms to computer labs, a new counseling center, and new lights and wood paneling on pilasters in the north hall of the second floor, among numerous other alterations. The exterior window openings were partially infilled with gray tiles and six-light windows of smoked glass. The windows in the light wells were also replaced.<sup>9</sup> The University Center, attached to the east end of the 2005 addition, was completed in 2013.

### *Sputnik and the National Defense Education Act*

On October 4, 1957, the Soviet Union launched the first earth-orbiting satellite, Sputnik, into outer space. Two months prior, the Soviets fired the first intercontinental ballistic missile (ICBM). These achievements left Americans feeling vulnerable to attack by air and inferior to the Soviets' technological advances. In the United States, critics argued that for the country to regain its technological leadership, a new emphasis had to be placed on mathematics, the sciences, and foreign languages. To that end, Congress responded with the National Defense Education Act (NDEA), Public Law 85-864, which President Dwight D. Eisenhower signed into law on September 2, 1958. The act is recognized as "the first example of comprehensive Federal education legislation." It was passed "[to] help ensure that highly trained individuals would be available to help America compete with the Soviet Union in scientific and technical fields."<sup>10</sup>

The NDEA was composed of ten titles. Title I had two general provisions. First, it acknowledged an educational emergency, one that was tied to the security of the nation. Section 101 of the act stated that "[the] defense of the Nation depends upon the mastery of modern techniques developed from complex scientific principles . . . [and] the discovery and development of new principles, new techniques, and new knowledge." The second provision was an assurance that nothing in the act was meant to assert Federal control over education. Title II dealt with student loans and how the loan funds would be allotted to each state. Title III dealt with strengthening science, mathematics, and foreign language instruction in secondary schools through the acquisition of equipment and minor remodeling of classrooms. It was under this title that the Enid school system received funding for the construction of the Enid High School Observatory. Title IV established a national fellowship program for graduate education with a preference given to students interested in becoming college teachers. Training of guidance counselors and the identification of gifted students were addressed in Title V. Title VI dealt with language development through Language

---

<sup>9</sup> Dawn Marks, "Enid High begins to add classrooms," *The Oklahoman*, July 15, 2004; Phyllis Zom, "Renovation Work around Enid schools is at a fever pitch," *Enid News and Eagle*, June 13, 2012; Curtis Tucker, "Renovations to Enid High School," *Enid Buzz*, August 21, 2012 (<http://www.enidbuzz.com/renovations-to-enid-high-school>) accessed August 4, 2017.

<sup>10</sup> Mary Beth Norton, David M. Katzman, Paul D. Escott, Howard P. Chudacoff, Thomas G. Patterson, and William M. Tuttle, Jr., *A People and a Nation: A History of the United States, Volume II: Since 1865*, Second Edition (Boston: Houghton Mifflin Company, 1986), pp. 864 and 896; "The Federal Role in Education," *U.S. Department of Education* (<https://www2.ed.gov/print/about/overview/fed/role.html>), accessed September 19, 2017.

Enid High School Observatory  
Name of Property

Garfield County, Oklahoma  
County and State

Area Centers and Language Institutes at colleges and universities that contracted with the government to offer these services. The language centers were available to teach people in government, private business, or education “modern Foreign Languages and to also offer understanding of a foreign region, including its history, economics, and geography, if deemed necessary. The institutes were for elementary and secondary school teacher training.” Title VII provided funding “for research and experimentation in the effective use of educational media such as television, radio, and films.” Title VIII provided funding for vocational education and “to meet the needs for technicians with science and technology training.” Title IX established the Science Information Service which operated under the National Science Foundation. Title X provided matching grants to states for “improving statistical services in state educational agencies.”<sup>11</sup>

Not all school districts were eager to accept NDEA funds. For some school districts this resistance was out of a fear of Federal control over local education even though Section 102 of Title I of the Act specifically stated that it did not authorize any such action. Early in the act’s history, the president of the Dallas (Texas) Board of Education stated the opinion that the program was ““rather a vicious thing.”” Believing that it would offer “no new services for Dallas school children,” the board voted not to accept the funds.<sup>12</sup>

The NDEA was renewed after four years and amended in 1964. References to inadequate education in science, mathematics, and modern foreign languages and insufficient technological training were struck from the Act. The focus of the program was expanded to include history, civics, geography, English, and reading in public elementary and secondary schools. It also made assistance to those who were teaching or preparing to teach disadvantaged youth, signaling the nation’s expanding focus on civil rights and poverty.<sup>13</sup>

Much of the focus on the NDEA after its passage was placed on its perceived mission to increase the number of trained scientists in the nation. However, historian and educator John L. Rudolph argues that the reforms in science education in the late 1950s and early 1960s “were specifically designed to foster an understanding of science among the majority destined for nonscientific occupations.” Rudolph also argues that “the substance of the new science education . . . was intended to be almost the exact opposite of technical training. There was an intellectual vigor for sure, but the new curricula were clearly conceived in the spirit of a broad liberal education.”

---

<sup>11</sup> Title I, Section 101 was reprinted in “Chapter 9: Division of Defense Education,” in State Board of Education of Oklahoma, *The Thirtieth Biennial Report of the State Department of Education, 1964*, p. 58; Wayne J. Urban, *More Than Science and Sputnik: The National Defense Education Act of 1958* (Tuscaloosa, Alabama: The University of Alabama Press, 2010), pp. 2-4.

<sup>12</sup> Pat Kelley Faught, “Dallas Schools Decide Against Federal Money,” *Dallas Morning News*, March 26, 1959. The school board president did acknowledge that the district accepted ““tiny tidbits”” of Federal money passed through the state board for vocational and special education programs. Specifically, Section 102 of Title I stated “Nothing contained in this Act shall be construed to authorize any department, agency, officer, or employee of the United States to exercise any direction, supervision, or control over the curriculum, program of instruction, administration, or personnel of any educational institution or school system.”

<sup>13</sup> Thomas C. Hunt, “National Defense Education Act (NDEA),” *Encyclopedia Britannica, Encyclopedia Britannica Online*, Encyclopedia Britannica Inc., 2017 (<https://www.britannica.com/topic/National-Defense-Education-Act>), accessed September 24, 2017.

Enid High School Observatory  
Name of Property

Garfield County, Oklahoma  
County and State

According to leading scientists and engineers, the goal of science education “was not to produce more scientists but rather a ‘change in the environment in which . . . scientists work.’” In a statement issued by the President’s Commission on National Goals it was argued that the gap that had formed between scientists and non-scientists should be closed by recognizing ““that science is in fact a noble intellectual and artistic pursuit.””<sup>14</sup> Whatever the intent of the reforms, it can be argued that Title III funding for the construction of an observatory sparked curiosity and created new opportunities for scientific and intellectual pursuits for many students at Enid High School.

*Oklahoma and Title III of the National Defense Education Act*

On September 26, 1958, Oklahoma’s State Department of Education established the Defense Education Division to implement the provisions of the NDEA.<sup>15</sup> Title III of the Act set forth a program through which funds paid to the Oklahoma State Department of Education would be expended for the approved projects of local public school districts. Specifically, the funds could be used for acquisition of laboratory and other special equipment and materials, and for minor remodeling of laboratory and other spaces. Only one application per school district was approved in each fiscal year. Funds received by the local district had to be matched dollar for dollar at the local level with public funds. The project could include any or all grades of public elementary school and eligible subjects in secondary schools. Any equipment that was purchased had to be “precisely suitable for improving instruction in science, mathematics and/or modern foreign languages.” It could not be rented or consumable (meaning it had to be durable) and could not be purchased from any communist country unless it was unavailable elsewhere.<sup>16</sup>

Oklahoma’s State Department of Education reinforced the matter of local control in its Biennial Reports. The first Biennial Report issued after the Act’s creation pointed out that states had long been recipients of Federal grants-in-aid for a variety of services and programs. It was noted that in 1960, Federal appropriations to education amounted to more than \$848,000,000. Of this amount, 17 per cent, or \$150,000,000, was appropriated for DNEA. The report stated that the program was perhaps “the most locally executed with the least amount of Federal control of any educational grants at the national level. It may serve as a precedent to be followed when other types of educational legislation are passed by Congress.”<sup>17</sup>

As would be expected, the number of the state’s school districts that received Title III funds grew during the first six years of the program. During the 1958-1959 allocation period, 340 school districts from 75 of Oklahoma’s 77 counties (or 25 per cent of the state’s districts) received funding. By 1963-1964, 637 school districts representing all 77 counties (55 per cent of the state’s

---

<sup>14</sup> John L. Rudolph, *Scientists in the Classroom: The Cold War Reconstruction of American Science Education*, (New York: Palgrave, 2004), pp. 169-70.

<sup>15</sup> State Board of Education of Oklahoma, *The Twenty-eighth Biennial Report of the State Department of Education of Oklahoma, 1960*, p. 221.

<sup>16</sup> State Board of Education of Oklahoma, *The Thirtieth Biennial Report of the State Department of Education, 1964*, pp. 59-60, and 61.

<sup>17</sup> State Board of Education of Oklahoma, *The Twenty-eighth Biennial Report of the State Department of Education of Oklahoma, 1960*, p. 222.

Enid High School Observatory  
 Name of Property

Garfield County, Oklahoma  
 County and State

districts) had participated. During this same period, the number of participating high school districts increased from 301 (51 per cent) to 424 (77 per cent) and only three high school districts never participated.<sup>18</sup> For the school year 1965-1966, of the state's 1035 school districts, 366 schools participated, representing 79 per cent of the students in Oklahoma's public schools.<sup>19</sup>

The Oklahoma State Department of Education tabulated the amount of allocated Federal funds by county, not by school district or city. Nor were records kept of the individual types of projects that were funded. Enid's school district was the only district that used Title III funds for the construction of an observatory. The chart below offers a comparison of allocations by selected counties. During the first six years of the program, Garfield County was third in the amount of allocated funds. Only Tulsa and Oklahoma counties, both with significantly larger populations, received more. However, Garfield County fell behind similarly sized counties later in the program.<sup>20</sup>

**Allocation of Title III Funds to School Districts in Oklahoma by Selected Counties**

County (largest city)	1958-1964	1965-1966
Canadian (El Reno)	41,530.87	7,203.90
Carter (Ardmore)	103,266.18	15,449.03
Cleveland (Norman)	146,316.47	31,585.14
Comanche (Lawton)	101,070.01	60,700.90
Garfield (Enid)	154,599.10	18,033.70
Kay (Ponca City)	131,926.84	21,316.32
Logan (Guthrie)	31,608.30	10,090.22
Muskogee (Muskogee)	92,147.61	3,714.60
Oklahoma (Oklahoma City)	1,016,693.84	362,211.08
Payne (Stillwater)	57,983.56	26,618.89
Pittsburg (McAlester)	39,071.76	7,083.52
Pottawatomie (Shawnee)	85,077.18	4,123.03
Tulsa (Tulsa)	478,166.40	163,751.23
Total All 77 Counties	4,666,409.07	1,165,481.32

The following table compares the number of approved projects in Oklahoma with those of its neighboring states during Fiscal Year 1963, the period during which the Enid school district used Title III funds for the construction of the Enid High School Observatory. Only Colorado had fewer approved projects than Oklahoma. However, considering that Texas had a far larger population,

<sup>18</sup> State Board of Education of Oklahoma, *The Thirtieth Biennial Report of the State Department of Education, 1964*, p. 64.

<sup>19</sup> State Board of Education of Oklahoma, *The Thirty-first Biennial Report of the State Department of Education of Oklahoma, 1966*, p. 66.

<sup>20</sup> State Board of Education of Oklahoma, *The Thirtieth Biennial Report of the State Department of Education, 1964*, p. 63; State Board of Education of Oklahoma, *The Thirty-first Biennial Report of the State Department of Education of Oklahoma, 1966*, pp. 92 and 94. These figures are not necessarily the actual expended amount.

Enid High School Observatory  
 Name of Property

Garfield County, Oklahoma  
 County and State

Oklahoma had more projects per student, perhaps another reflection of the Lone Star State's hesitancy to accept Federal funds.<sup>21</sup>

**Comparative number of approved Title III projects for acquisition of equipment and minor remodeling in specified subject field, by State for Fiscal Year 1963<sup>22</sup>**

State	Total	Science only	Mathematics only	Modern foreign languages only	Science & mathematics	Science & modern foreign languages	Mathematics & modern foreign languages	Science, mathematics, & modern foreign languages
All states & territories	48,912	27,882	9,020	6,930	2,281	577	30	2,192
Arkansas	995	637	212	146	0	0	0	0
Colorado	196	110	33	46	2	3	1	1
Kansas	727	496	105	126	0	0	0	0
Missouri	1,112	484	28	44	351	82	3	120
New Mexico	800	481	180	139	0	0	0	0
Oklahoma	608	189	11	3	250	18	2	135
Texas	621	248	3	9	128	57	0	176

Enid High School Observatory

Astronomy classes had been offered at EHS as early as 1920. Forty-two years later, school officials planned to advance the level of instruction far beyond that offered at other schools in Oklahoma. On November 5, 1962, the Enid Board of Education unanimously approved the use of the district's Title III funds for 1962-1963 for construction of an astronomy observatory on top of the high school's roof. The \$16,000 project had been put forward by the James (Jim) Smeltzer, a young, recently hired teacher in the school's science department. Smeltzer is credited with writing the approved grant proposal. The administration was instructed to proceed with plans and to receive bids for the construction of the observatory.<sup>23</sup>

<sup>21</sup> U.S. Department of Health, Education, and Welfare, Office of Education, *Report of the National Defense Education Act, Fiscal Years 1963*, p.85. In addition to Dallas, Houston and a few other school districts in Texas accepted no Federal aid. See Richard M. Morehead, "Most State Schools Accept U. S. Funds," *Dallas Morning News*, August 30, 1963.

<sup>22</sup> U.S. Department of Health, Education, and Welfare, Office of Education, *Report on the National Defense Education Act, Fiscal Year 1963*, p. 85. Arizona and Wyoming did not participate in the program during this fiscal year.

<sup>23</sup> *Enid Events* [Enid, Oklahoma], July 15, 1920; City of Enid, Oklahoma, Board of Education, Minutes of the Regular Meeting of November 5, 1962; "History of the EHS Observatory," *Dr. Nancy Currie-Gregg Observatory at Enid High School* <http://wewillfindstars.space/history.html> (accessed June 27, 2017).

Enid High School Observatory  
Name of Property

Garfield County, Oklahoma  
County and State

Planning for the observatory began at least as early as the spring of 1962. In June, John O. Paulson, president of Astro-Dome, Inc., a manufacturer of observatory domes, provided school officials with a quotation for two sizes of domes. The quoted price for a dome with an interior diameter of fourteen feet was \$6,845 and \$8,397 for a dome with an interior diameter of sixteen feet. The dome could be erected by the buyer's contractor or by Astro-Dome. If the latter, the cost would increase \$3,000 to \$3,200, depending on the size of the dome. There would also be additional costs of \$100 a day for the company to have an engineer on site. Taking into account regional considerations, Paulson assured school officials that the company's domes were "designed to withstand heavy wind loads which are common to your area."<sup>24</sup>

A month after approving the use of Title III funds for an observatory for the high school, the school board reviewed bids for the construction of the sub-structure, or base, for its dome. The concrete block circular base was designed by Wheeler and Wheeler, the successor firm to R. W. Shaw. Wheeler and Wheeler designed a number of projects for the school district in the post-World War II-era. Two local construction companies submitted bids; D. C. Bass Company's bid was \$4,209 and P. C. Davis & Sons Construction Company's bid was \$3,464. One of the architects called P. C. Davis & Sons to obtain an estimate for the cost of raising the height of the sub-structure from six to seven feet. When a representative of the company advised the board that the change order would increase their bid by \$529.00, bringing the total to \$3,993, the board unanimously awarded the contract to the company. The board awarded an additional amount of \$3,376 to the company on February 4, 1963 for the erection of the Astro-Dome, painting the exterior masonry of the sub-structure, building a pedestal for the telescope, and installing a platform.<sup>25</sup> This time frame suggests that the observatory was completed in the spring or summer of 1963.

Two years later, school officials used Title III funds to purchase a state-of-the-art telescope for use in the observatory. The model chosen was a Tinsley Laboratories 8-inch Model D Cassegrain, said to be popular with "advanced" amateurs and schools. The "8-inch" referred to the primary mirror diameter. The telescope included "carefully planned, tapered light baffles . . . added in front of the primary and secondary mirrors to produce the darkest field possible, a feature of extreme importance for deep-sky work." Also ordered at the same time was a 3-inch guiding refractor and a 45-inch high pier for the telescope. The F/13 refractor was the main guiding telescope for the 8-inch Cassegrain and was equipped with illuminated crosshairs that could be varied in brightness. Total cost for the three items which were expected to arrive in October 1965 was \$2,117.50.<sup>26</sup> The

---

<sup>24</sup> John O. Paulson, President, Astro-Dome, Inc. to O.T. Outry, Enid, Oklahoma, May 12, 1962 (Paulson's signature was dated June 12, 1962), "Telescope and Dome" File, Classroom of Dusty Hugaboom, Enid High School, Enid, Oklahoma.

<sup>25</sup> City of Enid, Oklahoma, Board of Education, Minutes of the Regular Meeting of December 3, 1962 and February 4, 1963.

<sup>26</sup> M. H. Miller, Business Manager, Enid Public Schools, to Tinsley Laboratories, Inc., October 12, 1965, Telescope and Dome" file; Advertisement for Tinsley Model B 8-Inch f/16 Cassegrain Telescope, *Sky and Telescope*, (February, 1964): 107.



Enid High School Observatory  
Name of Property

Garfield County, Oklahoma  
County and State

school district also purchased two 6-inch Model RV-6 telescopes from Criterion Manufacturing Company around this time.<sup>27</sup>

The observatory and its telescopes brought physics teacher Jim Smeltzer and his astronomy students recognition from within the school and beyond. Smeltzer and students were pictured in several EHS yearbooks posing with telescopes and related equipment (see Figures 7 and 8). An astronomy club was formed “to forward students with this interest.”<sup>28</sup>

Outside recognition came in March 20, 1966 when the state’s largest newspaper, Oklahoma City’s *Daily Oklahoman* published an article on the observatory and its impact on students at EHS. The article asked the question “How do you develop a high school student into an extraordinarily well-informed young man or woman?” The answer it gave included a school district which “cares enough to provide the only high school astronomy observatory in the state . . . . a group of pupils who are ambitious enough to devote considerable after-school time to a complex assignment . . . . [and] a large business firm which is impressed to the extent that it permits the students access to a \$125,000 computer.” The article discussed the high quality photographs the students were able to take (and also develop themselves) of the moon “and other objects in space” through the use of an ordinary 35mm camera. It also discussed the work students were doing with the computer, an IBM 1620, which an employee of the unnamed firm volunteered two evenings a week to teach the students how to use it. The students recorded light from the stars on a photoelectric cell in the observatory. That information along with variables were put into an equation and then fed into a computer. Accompanying the article were photographs that depicted the observatory, students working with the 8-inch Tinsley Cassegrain telescope, teacher Jim Smeltzer examining a portable telescope, and a detailed shot of the moon taken by one of the students.<sup>29</sup>

Senior students Jean Christensen, Georgia Wykoff, Gerald Smith, Alan Mathis, and Steve Glasser presented the findings from their observations and computer analysis in a paper at the Ninth Annual Meeting of the Oklahoma Junior Academy of Science held at Oklahoma State University in Stillwater in April 1966. The paper was titled “Multicolor Observations of Variable Stars and a Program for Reduction by Computer.” According to an abstract of the paper published in *Transactions of the Oklahoma Junior Academy of Science*:

The observations were taken with an 8-inch Tinsley Cassegrain reflector, using three-color photometry. Results from a recorder were then corrected for sky conditions and punched on cards for use by the computer. The use of the computer was needed, since it takes about one hour to complete the calculations for each observation. Meaningful results were obtained only from many observations, and the computer aided immensely in producing the results.

<sup>27</sup> Michael F. Krewalk, Criterion Manufacturing Company, to Board of Education, District No. 57, August 24, 1965, “Telescope and Dome” File.

<sup>28</sup> *The Quill*, Volume XXXII, May 1965, pp. 29 and 98, and *The Quill*, Volume XXXIII, May 1966, pp. 13 and 29.

<sup>29</sup> Calvin Bergdall, “Enid High’s Eager Moonlighters,” *Daily Oklahoman*, March 20, 1966; *Transactions of the Oklahoma Junior Academy of Science* (Volume IX, Published 1966): 270-73.

Enid High School Observatory  
Name of Property

Garfield County, Oklahoma  
County and State

In addition, each of the five student authors was listed on the Academy's Honor Roll for 1966.<sup>30</sup>

More recognition came in April 1966 when the school's physics department was among ten in the nation recognized for the excellence of its programs by the American Association of Physics Teachers and the American Institute of Physics. When the selection was announced in the *Enid Daily Eagle* it was noted that the school's astronomy class was one of a few in the southwest and an important factor in the department's selection for the commendation. Schools that received the award were selected on the basis of size and regional representation. The other schools selected that year were from Palos Verdes Estates, California; Logan, New Mexico; Denver, Colorado; Salem, Oregon; Houston, Texas; Des Moines, Iowa; Spartanburg, South Carolina; Wallington, Connecticut; and Fort Wayne, Indiana. In the eight years since the inception of the award, EHS was the first high school in Oklahoma to be so honored. As part of the announcement, the newspaper published a photograph of Mr. Smeltzer with two students, Gerald Smith and Jean Christensen, using the telescope inside the dome. The timing of the recognition was particularly appropriate as the 1965-1966 school year was Smeltzer's last year at EHS.<sup>31</sup>

The Enid High School Observatory was used by a larger audience than just the city's high school students. Early in each school year, junior high school teachers attended workshops that reacquainted them with the subject of astronomy. Several nights during the school year, junior high school students were invited to an open house where the high school's four smaller telescopes were set up on the school's roof. Teacher Jim Smeltzer and his protégées engaged the students in conversations regarding what they were viewing. Smeltzer was convinced that these encounters sparked curiosity among the younger students and contributed to the yearly increase in enrollment in physics and astronomy classes at the high school.<sup>32</sup>

After Smeltzer left, Nolen Harsh, an EHS graduate, accepted the assignment of teaching physics and astronomy at the school as well as oversight of the observatory for the 1967-1968 academic year. He retired from EHS in 1991. Dusty Hugaboom began teaching physical science at EHS in 1994 and since 2000, he has been teaching astronomy and introducing students to the wonders of space through EHS's observatory.<sup>33</sup>

---

<sup>30</sup> *Transactions of the Oklahoma Junior Academy of Science* (Volume IX, Published 1966): 270-73, 297. The students' advisors for the paper were teachers Mary Evelyn Adams and Jim Smeltzer. It should be noted that an Enid High School sophomore, Kenneth L. Jones, had his paper "Voltage-Producing Capabilities of *Escherichia coli* Exposed to Sonic Radiation" published in its entirety and senior Dirk Hutchinson had an abstract of his paper "The Effectiveness of Fungicides on *Aspergillus flavus*," published in the same volume of *Transactions of the Oklahoma Junior Academy of Science* (see pages 287-89 and 300). Jim Smeltzer was these students advisor as well. Jones was named to the Honor Roll in 1966 and Hutchinson was listed in 1965 and 1966. No other Enid students were listed in 1966.

<sup>31</sup> *Enid [Oklahoma] Daily Eagle*, April 7, 1964, pp. 10 and 14.

<sup>32</sup> Bergdall, "Enid High's Eager Moonlighters."

<sup>33</sup> Rick Hockmeyer, "Tribute to Nolen Harsh," *Dr. Nancy Currie-Gregg Observatory at Enid High School* (<http://wewillfindstars.space/nolen-harsh.html>) assessed June 27, 2017; Autum Talamante, "Tribute to Dusty Hugaboom," *Dr. Nancy Currie-Gregg Observatory at Enid High School* (<http://wewillfindstars.space/dusty-hjgaboomb.html>) assessed September 26, 2017.

Enid High School Observatory  
Name of Property

Garfield County, Oklahoma  
County and State

The Enid High School Observatory continues to inspire students at EHS and remains the only high school observatory in the state.<sup>34</sup> A renewed interest in the observatory will insure that it will do so for many years along with the possibility of expanding its reach to other school districts across the state. The wife and husband team of retired astronaut Dr. Nancy Currie-Gregg, a veteran of four space shuttle missions, and EHS alumnus Tim Gregg are spearheading a fund-raising campaign to purchase a new digital telescope for the observatory and a robotic mount, to repair and renovate the dome, and create an on-campus viewing control room that would allow for images to be viewed remotely. Funds could also be used for a development stipend for area science teachers and to improve instruction in STEM (Science, Technology, Engineering, and Math) classes. In addition, the observatory has been named the Dr. Nancy Currie-Gregg Observatory in honor of Dr. Currie-Gregg.<sup>35</sup>

*Astro-Dome, Inc.*

Even before Houston's "Eighth Wonder of the World" opened in 1965, the name "Astro-Dome" was a familiar one, at least to readers of publications such as *Sky and Telescope* and to other astronomy fans. Astro-Dome, Inc. was a company in Canton, Ohio that specialized in the manufacture of observatory domes. The domes varied in size from an inside diameter of ten feet up to twenty-five feet and in 1962 ranged in price from \$4,971 to \$14,415. The domes found favor with professional and amateur astronomers and were frequently used at high schools and universities. The smaller domes (ten- to fourteen-foot interior diameter) were referred to as Domettes and were developed for high schools and junior colleges. However, it is interesting to note that EHS did not select one of the smaller-sized domes for its observatory but instead purchased a dome with a sixteen-foot interior diameter. According to the company's advertisements, more Astro-Domes were in use than any other type of dome. By the mid-1960s, Astro-Domes had been installed at Washburn University in Topeka, Kansas; Indiana State Teachers College, Terre Haute, Indiana; the University of Wisconsin; on top Cardwell Hall, a new science building at Kansas State University, Manhattan, Kansas; and Taft School in Watertown, Connecticut, among others. An Astro-Dome was chosen to replace the original dome at the Shattuck Observatory at Dartmouth College, Hanover, New Hampshire, which had been built in 1853-1854.<sup>36</sup>

In 1959, John O. Paulson, president of Astro-Dome, filed a patent with the U. S. Patent Office for shutters for observatory domes. Paulson's design addressed a deficiency common to dome

---

<sup>34</sup> Jenks High School, Jenks, Oklahoma recently opened a planetarium. See "History of the EHS Observatory."

<sup>35</sup> Mike Coppock, "Reaching for the Stars: Astronaut, husband lead fundraising campaign for Enid observatory," *The Oklahoman*, March 7, 2017. Dr. Currie-Gregg obtained the rank of Colonel in the U.S. Army, starting as a helicopter pilot. She was selected as an astronaut in 1990 and logged 1,000 hours in space that included the first assembly mission for the International Space Station in 1998 and servicing the Hubble Space Telescope in 2002, her last mission. She received a doctorate in industrial engineering from the University of Houston and now teaches at Texas A&M University, College Station.

<sup>36</sup> Promotional brochures for Astro-Dome Inc. found in the file "Telescope and Dome," Classroom of Dusty Hugaboom, Enid High School, Enid, Oklahoma.

Enid High School Observatory  
Name of Property

Garfield County, Oklahoma  
County and State

construction—namely to provide a water-tight environment when the shutters were fully closed. In Paulson’s design, this was accomplished through various baffles and drain troughs that presented a “torturous path through which water entering the joint between the shutters will be conducted and drained on the exterior of the dome, when the shutters are in the closed position.” Baffles and drain troughs were also provided at the outer edges of the shutters and their frames. The design for the shutters and frames included longitudinal curves meant to conform to the curvature of the semi-spherical dome. Paulson’s patent for “Water-tight Shutter Construction for Observatory Domes” was approved on August 22, 1961 (Figures 4-6).<sup>37</sup>

Jim (James Franklin) Smeltzer (1937-2006)

Jim Smeltzer grew up in Sapulpa, Oklahoma and graduated from the local high school in 1956. He received his undergraduate degree from Oklahoma Baptist University in 1959 and a master’s degree from the University of Oklahoma in 1961. After graduating from OU, he accepted a teaching position at Enid High School. After leaving EHS, he and his wife, Naoma, and children, Lisa and Mark, moved to Stillwater where he pursued a doctorate. Daughter Sherry was born in Stillwater. After studying with Dr. Beverly Bookmyer at the University of Arizona’s Mount Lemmon Observatory, he received a PhD in 1968. In 1969, he became a professor of Physics and Astronomy at Northwest Missouri State University. Before his retirement in 2003, he supervised the construction of an observatory for the school near Mozingo Lake east of Maryville, Missouri.<sup>38</sup>

R. W. Shaw, architect (1880-1947)

R. (Roy) W. Shaw was born on September 21, 1880 in Genesco, Illinois. He moved with his family to Enid just seven years after the city was founded with the opening of the Cherokee Outlet. By 1906, Shaw was practicing architecture in the city. He soon became Enid’s most prolific architect.<sup>39</sup> In 1913, Shaw and A. A. Crowell were the architects for buildings at the Institute for Feeble Minded located in Enid. A later project included a gymnasium at Enid’s Phillip’s University. Educational institutions were a specialty and Shaw designed most of Enid’s public schools beginning with Enid High School in 1911-1912 until his death in 1947, at which time he was working on plans to renovate the building as a result of heavy damage from a fire in 1943.<sup>40</sup>

---

<sup>37</sup> United States Patent Office, “Water-tight Shutter Construction for Observatory Domes,” Patent Number 2,996,844, August 22, 1961.

<sup>38</sup> Sherry Smeltzer Barnes, “Tribute to Jim Smeltzer,” *Dr. Nancy Currie-Gregg Observatory at Enid High School*, <http://wewillfindstars.space/jim-smeltzer.html> (accessed June 27, 2017); “Dr. James Franklin Smeltzer,” *Bram-Danfelt Funeral Home*, [http://www.bramfuneralhome.com/obituaries/print?o\\_id=951296](http://www.bramfuneralhome.com/obituaries/print?o_id=951296) (accessed August 8, 2017). Sherry Smeltzer Barnes was Jim Smeltzer’s daughter. In her essay, she wrote that the family moved to Stillwater in 1965. If that was the case, then Mr. Smeltzer must have commuted back and forth to Enid as it is know he was still teaching at EHS during the second semester of the 1965-1966 school year.

<sup>39</sup> Richard Mize, “Story of Enid, Oklahoma, architect R. W. Shaw, 1880-1947, yet to be fully told,” *Oklahoman*, May 16, 2015, updated May 17, 2015; *C. R. Wallin & Co’s, Enid, Oklahoma Business Directory, 1906*, p. 233.

<sup>40</sup> Daily Oklahoman, August 24, 1913 and February 11, 1940; Rachel Nugent and Sophie Roark, “Harrison School, Enid, Garfield County, Oklahoma,” National Register of Historic Places Registration Form, NRIS #100001073.

Enid High School Observatory  
Name of Property

Garfield County, Oklahoma  
County and State

While practicing in Enid, he served as a member of the state board of architects and was a three-term president of the Oklahoma chapter of the American Institute of Architects.<sup>41</sup> Shaw died on October 3, 1947 at an Enid Hospital. One of his last projects was the rehabilitation of Enid High School as the district endeavored to put the building back in use following the 1943 fire. Shaw's associate Marion Norris (M. N.) Wheeler took over the project following the school district's settlement with Shaw's estate giving the district full rights to the plans.<sup>42</sup>

Numerous Shaw-designed buildings are listed in the National Register. Listed properties in Enid include McCristy Knox Mansion (NR 1987), Jackson School (NR 1989), H. H. Champlin House (NR 1992), Clay Hall (NR 2012), Marshall Hall (NR 2015), and Harrison School (NR 2017).

### *Wheeler and Wheeler, architects*

Marion Norris Wheeler worked as a draftsman for R. W. Shaw, Enid's most prolific architect during the first half of the twentieth century. As mentioned above, when Shaw died in 1947, Marion Wheeler assumed responsibility for the completion of the reconstruction of Enid High School. Norris Glen Wheeler joined his father's firm, M. N. Wheeler, Architect, at this time. Norris graduated from Oklahoma A&M College, Stillwater, in 1946 with a degree in mechanical engineering and became a licensed engineer and architect. Another son, Elbert Wheeler, received a bachelor's and master's degrees from Oklahoma A&M and then worked in his father's firm. The trio was working under the name Wheeler and Wheeler at least as early as 1955. The elder Wheeler died in 1958. After the death of Norris Wheeler in 1996, Elbert renamed the firm Elbert M. Wheeler, Architect and continued to work into the 1990s. He died in 2011.<sup>43</sup>

Wheeler and Wheeler designed numerous building in the Enid area. Among them are Briggs Auditorium at Phillips University, Enid (1958, NR 2017), General Mills Office, Enid (1959) Theta Kappa Tau Fraternity House, Stillwater, and Central Christian Church and Wallace Shopping Center, Enid, (all 1961), and the Kingfisher Savings and Loan, Enid (1966).<sup>44</sup>

### *P. C. Davis & Sons Construction Company*

P. C. Davis & Sons Construction Company built numerous buildings across north central Oklahoma during the mid-twentieth century. It was the contracting firm responsible for the construction of the base for the Enid High School Observatory designed by Wheeler and Wheeler as well as constructing its dome based on the plans provided by the manufacturer, Astro-Dome, Inc. A sampling of projects built by the firm includes an addition to the Mistletoe Express Co. plant for the Oklahoman-Times Northwest News Bureau, Enid (c. 1955), Easterling Hall, a

<sup>41</sup> "Roy Shaw Rites Planned in Enid," *Daily Oklahoman*, October 4, 1947.

<sup>42</sup> Ibid.; "Wheeler Appointed to Enid School Job," *Daily Oklahoman*, November 7, 1947.

<sup>43</sup> Sherry N. DeFreece Emery, "Reconnaissance Survey of the Indian Hills Subdivision, Enid, Garfield County, Oklahoma," (June 2016), p. 93; *Daily Oklahoman*, March 3, 1955.

<sup>44</sup> Ibid.; *American Architects Directory*, Second edition (R. R. Bowker LLC), (<http://public.aia.org/hdoaa/wiki/Wiki%20Pages/1962%20American%20Architects520Directory.aspx>), accessed July 11, 2017.

Enid High School Observatory  
Name of Property

Garfield County, Oklahoma  
County and State

women's dormitory at Northern Oklahoma Junior College, Tonkawa (1957), U. S. Post Office, Hennessey (c. 1961), Evelyn Zollars Library and Administration Building, Phillips University, Enid (c. 1963), a grade school in Cherokee (1964), O. T. Autry Vocational-Technical Training Center, Enid (1967), and the Northwestern State College stadium, Alva (1968). The company is still in business.<sup>45</sup>

## Conclusion

The Enid High School Observatory, now known as the Dr. Nancy Currie-Gregg Observatory, illustrates one school district's unique response to opportunities for improving science education through Federal funding as a result of the National Defense Education Act of 1958. Enacted at a time of national insecurity following the Soviet Union's launch of the earth-orbiting satellite, Sputnik, the NDEA was intended to address perceived weaknesses in science, mathematics, and modern foreign language instruction and insufficient technological training in the nation's schools. As a result, the Enid High School Observatory was the state's only high school observatory during the period of significance and retains that distinction to date. Incorporating the observatory into the school's curriculum brought national attention to its physics program and state recognition to students. For these reasons, the Enid High School Observatory is eligible for listing in the National Register of Historic Places at the state level of significance in the area of Education. The period of significance begins in 1963, the year the observatory was constructed on the school's roof, and ends in 1968. The latter date acknowledges the observatory's continued use as an educational tool and corresponds to the National Register's 50-year criterion.

---

<sup>45</sup> *Daily Oklahoman*, March 3, 1955, May 27, 1956, May 12, 1957, October 6, 1960, January 24, 1964, October 1, 1966, and November 30, 1967; *U. S. School Yearbooks, 1880-2012*; Yearbook Title: *Phillipian*; Year: 1963 [p. 239], Ancestry.com (accessed September 26, 2017).



Enid High School Observatory  
Name of Property

Garfield County, Oklahoma  
County and State

---

## 9. Major Bibliographical References

**Bibliography** (Cite the books, articles, and other sources used in preparing this form.)

Barnes, Sherry Smeltzer. "Tribute to Jim Smeltzer." *Dr. Nancy Currie-Gregg Observatory at Enid High School*, <http://wewillfindstars.space/jim-smeltzer.html> (assessed June 27, 2017).

Bergdall, Calvin. "Enid High's Eager Moonlighters." *Daily Oklahoman* [Oklahoma City], March 20, 1966.

Brown, Gary L. "Enid." *The Encyclopedia of Oklahoma History and Culture* ([www.okhistory.org](http://www.okhistory.org)) accessed July 13, 2017.

\_\_\_\_\_, compiler. "History of Enid High School," *EnidHistory.org, LLC*, 2004, ([www.brownlaw-ok.com/enidhistory/articles/enidhigh.pdf](http://www.brownlaw-ok.com/enidhistory/articles/enidhigh.pdf)) accessed July 13, 2017.

Bruce, William C., compiler. *High School Buildings*. Milwaukee, Wisconsin, 1913.

City of Enid, Oklahoma. Board of Education. Minute Records. Enid, Oklahoma School District.

*Daily Oklahoman* (later titled *The Oklahoman*) [Oklahoma City, Oklahoma]. Various issues.

*Dr. Nancy Currie-Gregg Observatory at Enid High School*. (<http://wewillfindstars.space>).

Emery, Sherry N. DeFreece. "Reconnaissance Survey of the Indian Hills Subdivision, Enid, Garfield County, Oklahoma," June 2016.

*Enid* [Oklahoma] *Daily Eagle*, Various issues.

"Enid Opening New School," *Daily Oklahoman* [Oklahoma City], April 18, 1948.

"History of the EHS Observatory." *Dr. Nancy Currie-Gregg Observatory at Enid High School*. (<http://wewillfindstars.space/history.html>) assessed June 27, 2017.

McIntyre, Glen V. *Enid: 1893-1945*. Charleston, SC: Arcadia Publishing, 2012.

Mize, Richard. "Story of Enid, Oklahoma, architect R. W. Shaw, 1880-1947, yet to be fully told," *The Oklahoman*, May 16, 2015/Updated May 17, 2015.

Nugent, Rachel and Sophie Roark. "Harrison School, Enid, Garfield County, Oklahoma." National Register of Historic Places Registration Form, NRIS #100001073.

Enid High School Observatory  
Name of Property

Garfield County, Oklahoma  
County and State

Oklahoma. State Board of Education. *The Twenty-eighth Biennial Report of the State Department of Education of Oklahoma, 1960.*

\_\_\_\_\_. *The Thirtieth Biennial Report of the State Department of Education of Oklahoma, 1964.*

\_\_\_\_\_. *The Thirty-first Biennial Report of the State Department of Education of Oklahoma, 1966.*

*The Quill.* Enid [Oklahoma] High School Annual. Volume XXX, May 1963.

*The Quill.* Enid High School Annual. Volume XXXI, May 1964.

*The Quill.* Enid High School Annual. Volume XXXII, May 1965.

*The Quill.* Enid High School Annual. Volume XXXIII, May 1966.

*The Quill.* Enid High School Annual. Volume XXXV, May 1968.

*The Quill.* Enid High School Annual. Volume XXXVI, May 1969.

Rudolph, John L. *Scientists in the Classroom: The Cold War Reconstruction of American Science Education.* New York: Palgrave, 2002.

*Sky and Telescope.* Various issues, 1964.

“Telescope and Dome.” File, Classroom of Dusty Hugaboom, Enid High School, Enid, Oklahoma.

*Transactions of the Oklahoma Junior Academy of Science. Papers Presented at the Ninth Annual Meeting, April 15-16, 1966 at Oklahoma State University, Stillwater, Oklahoma.* Volume IX. Published 1966.

Turner, Alvin O. “Cherokee Outlet Opening.” *The Encyclopedia of Oklahoma History and Culture* (www.okhistory.org) accessed September 14, 2017.

U.S. Department of Health, Education, and Welfare. Office of Education. *Report of the National Defense Education Act, Fiscal Years 1961 and 1962.*

\_\_\_\_\_. *Report of the National Defense Education Act, Fiscal Year 1963.*

United States Patent Office. “Water-tight Shutter Construction for Observatory Domes.” Patent Number 2,996,844. August 22, 1961.

Enid High School Observatory  
Name of Property

Garfield County, Oklahoma  
County and State

Urban, Wayne J. *More Than Science and Sputnik: The National Defense Education Act of 1958.*  
Tuscaloosa: The University of Alabama Press, 2010.

---

**Previous documentation on file (NPS):**

- preliminary determination of individual listing (36 CFR 67) has been requested
- previously listed in the National Register
- previously determined eligible by the National Register
- designated a National Historic Landmark
- recorded by Historic American Buildings Survey # \_\_\_\_\_
- recorded by Historic American Engineering Record # \_\_\_\_\_
- recorded by Historic American Landscape Survey # \_\_\_\_\_

**Primary location of additional data:**

- State Historic Preservation Office
- Other State agency
- Federal agency
- Local government
- University
- Other

Name of repository: Enid High School, Enid, Oklahoma

**Historic Resources Survey Number (if assigned):** \_\_\_\_\_

---

**10. Geographical Data**

**Acreage of Property** approximately 1.7 acres

Use either the UTM system or latitude/longitude coordinates

**Latitude/Longitude Coordinates**

Datum if other than WGS84: \_\_\_\_\_  
(enter coordinates to 6 decimal places)

1. 363.388200                      -97.886300

Enid High School Observatory  
Name of Property

Garfield County, Oklahoma  
County and State

**Verbal Boundary Description** (Describe the boundaries of the property.) The boundaries of the nominated resource includes only the footprint of the 1912 Enid High School building and its additions to 1965. Starting at the northwest corner of the 1912 building, proceed east approximately 200 feet to the northeast corner of the building; then proceed south approximately 110 feet to the intersection of the 1912 building and the auditorium wing; then proceed east approximately 45 feet to the northeast corner of the auditorium wing; then proceed south approximately 180 feet to the southeast corner of the auditorium wing; then proceed west approximately 225 feet to the west wall of the gymnasium wing; then proceed approximately 40 feet south to the southeast corner of the gymnasium wing; then proceed approximately 65 feet west to the southwest corner of the gymnasium wing; then proceed north approximately 220 feet to the northwest corner of the gymnasium wing; then proceed east approximately 45 feet to the intersection of the gymnasium wing with the 1912 building; then proceed north approximately 110 feet to the place of beginning (see Map 5).

**Boundary Justification** (Explain why the boundaries were selected.) The focus of the nomination is the observatory on the roof of Enid High School. The selected boundaries include only the area containing the footprint of the building on which the observatory sits. The period of significance is defined by 1963 to 1968, therefore later additions and adjacent resources are not included within the boundaries of the nominated resource.

---

### 11. Form Prepared By

name/title: Susan Allen Kline, consultant, on behalf of Tim Gregg and Dr. Nancy Currie-Gregg

organization: \_Friends of the Currie-Gregg Observatory at Enid High School\_\_\_\_\_

street & number: 3515-B Longmire, #326\_\_\_\_\_

city or town: College Station\_\_\_\_\_ state: Texas\_\_\_\_\_ zip code: 77845\_\_\_\_\_

e-mail friends@currie-gregg.space)\_\_\_\_\_

telephone: 713-385-8589\_\_\_\_\_

date: September 30, 2017\_\_\_\_\_

---

Enid High School Observatory  
Name of Property

Garfield County, Oklahoma  
County and State

### **Additional Documentation**

Submit the following items with the completed form:

- **Maps:** A **USGS map** or equivalent (7.5 or 15 minute series) indicating the property's location.
- **Sketch map** for historic districts and properties having large acreage or numerous resources. Key all photographs to this map.
- **Additional items:** (Check with the SHPO, TPO, or FPO for any additional items.)

### **Photographs**

Submit clear and descriptive photographs. The size of each image must be 1600x1200 pixels (minimum), 3000x2000 preferred, at 300 ppi (pixels per inch) or larger. Key all photographs to the sketch map. Each photograph must be numbered and that number must correspond to the photograph number on the photo log. For simplicity, the name of the photographer, photo date, etc. may be listed once on the photograph log and doesn't need to be labeled on every photograph.

### **Photo Log**

Name of Property: Enid High School Observatory

City or Vicinity: Enid

County: Garfield

State: Oklahoma

Photographer: Susan Allen Kline

Date Photographed: July 5-6, 2017

Description of Photograph(s) and number, include description of view indicating direction of camera:

- 1 of 10. North (front) elevation of Enid High School. View southwest
- 2 of 10. East elevation of Enid High School. View southwest.
- 3 of 10. West elevation of Enid High School with view of EHS Observatory on roof. View southeast.
- 4 of 10. South elevation of Enid High School. View north.
- 5 of 10. Headhouse/room on roof. View northeast.
- 6 of 10. North side of observatory with shutters open. View south.

Enid High School Observatory  
Name of Property

Garfield County, Oklahoma  
County and State

- 7 of 10. Southeast side of observatory. View northwest.
- 8 of 10. Interior of observatory, viewing platform with Tinsley telescope. View south.
- 9 of 10. Interior of observatory, east stairs to viewing platform. View southeast.
- 10 of 10. Interior of observatory, viewing platform with Tinsley telescope. View southeast.

### Figure Log

1. Map 1: Enid High School Observatory, latitude and longitude map.
2. Map 2: Enid High School Observatory, context map.
3. Map 3: Sanborn Fire Insurance Company Map, Enid, OK, Sheet 30, 1930 updated to 1947.
4. Map 4: Detail of Sanborn Fire Insurance Map Company, Enid, Oklahoma, Sheet 30, 1930 updated to 1947 showing Enid High School with 1920 addition.
5. Map 5: Current site plan of permanent buildings on the Enid High School campus.
6. Figure 1: Rendering of Enid High School from *Enid Daily Eagle*, February 5, 1911.
7. Figure 2: Photo of Enid High School from *High School Buildings* (1913).
8. Figure 3: Aerial view of Enid High School, c. 1950.
9. Figure 4: Drawings of Astro-Dome from Patent #2,966,844.
10. Figure 5: Drawing of Astro-Dome from Patent #2,966,844.
11. Figure 6: Drawings of Astro-Dome from Patent #2,966,844.
12. Figure 7: Photo of observatory from *The Quill* (May 1965).
13. Figure 8: Physics teacher Jim Smeltzer with students and telescope, *The Quill* (May 1966).
14. Figure 9: Aerial view of EHS Observatory, from *The Quill* (May 1967).

**Paperwork Reduction Act Statement:** This information is being collected for applications to the National Register of Historic Places to nominate properties for listing or determine eligibility for listing, to list properties, and to amend existing listings. Response to this request is required to obtain a benefit in accordance with the National Historic Preservation Act, as amended (16 U.S.C.460 et seq.).

**Estimated Burden Statement:** Public reporting burden for this form is estimated to average 100 hours per response including time for reviewing instructions, gathering and maintaining data, and completing and reviewing the form. Direct comments regarding this burden estimate or any aspect of this form to the Office of Planning and Performance Management, U.S. Dept. of the Interior, 1849 C. Street, NW, Washington, DC.

**United States Department of the Interior**  
National Park Service

**National Register of Historic Places**  
**Continuation Sheet**

Enid High School Observatory
Name of Property
Garfield County, Oklahoma
County and State
Name of multiple listing (if applicable)

Section number MAP Page 1

Map 1: Enid High School Observatory, -97.886300, 36.388200

Enid High School Observatory  
611 West Wabash Avenue  
Enid, Garfield County, Oklahoma





Enid High School Observatory  
611 West Wabash Avenue  
Enid, Garfield County, Oklahoma



Source: Esri, DigitalGlobe, GeoEye, Earthstar Geographics, CNES/Airbus DS, USDA, USGS, AEX, Getmapping, Aerogrid, IGN, IGP, swisstopo, and the GIS User Community

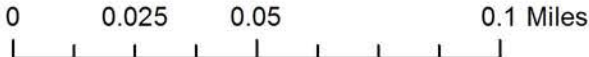



United States Department of the Interior  
National Park Service

National Register of Historic Places  
Continuation Sheet

Enid High School Observatory
Name of Property
Garfield County, Oklahoma
County and State
Name of multiple listing (if applicable)

Section number MAP Page 2

Map 2: Context Map, <http://openstreetmap.org>, retrieved September 15, 2017

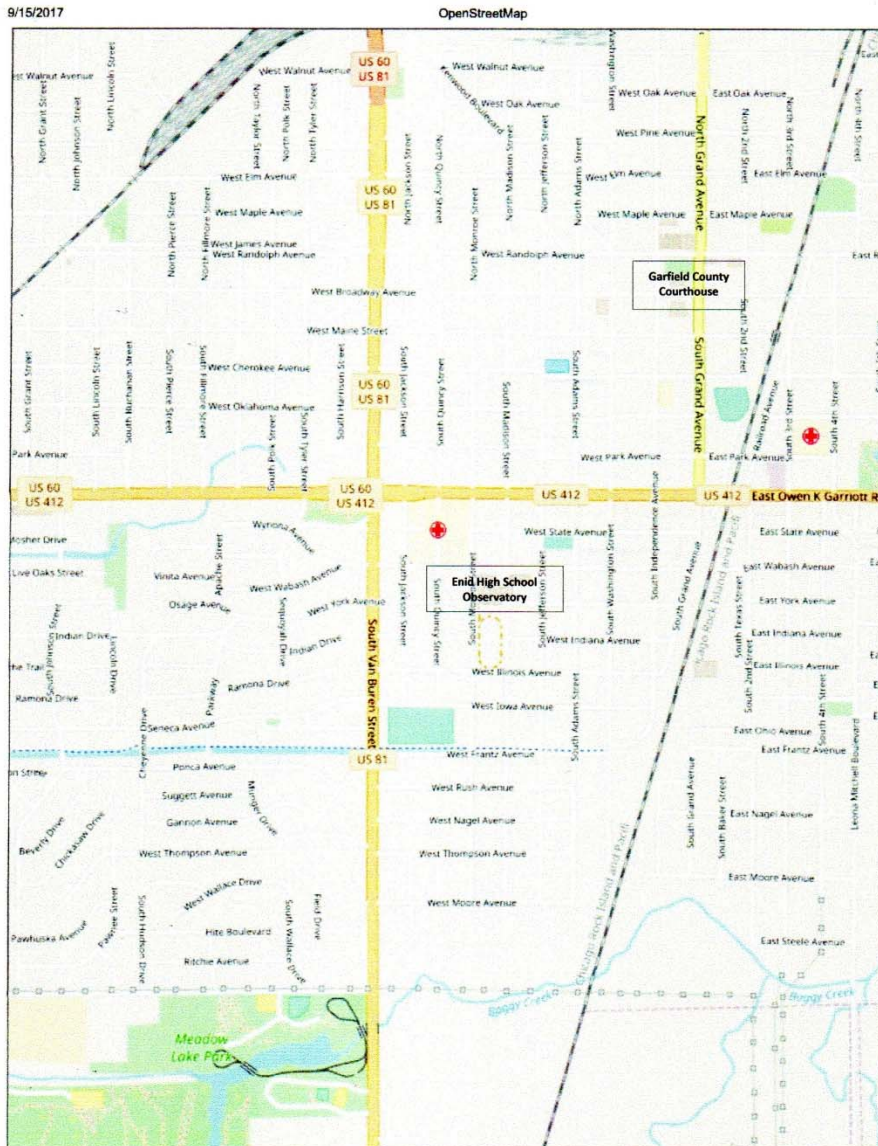

United States Department of the Interior  
National Park Service

National Register of Historic Places  
Continuation Sheet

Enid High School Observatory
Name of Property
Garfield County, Oklahoma
County and State
Name of multiple listing (if applicable)

Section number MAP Page 3

Map 3: Sanborn Fire Insurance Company Map, Enid, OK, Sheet 30, 1930 updated to 1947. Enid High School is in lower right corner.





United States Department of the Interior  
National Park Service

National Register of Historic Places  
Continuation Sheet

Enid High School Observatory
Name of Property
Garfield County, Oklahoma
County and State
Name of multiple listing (if applicable)

Section number MAP Page 4

Map 4: Detail of Sanborn Fire Insurance Map Company, Enid, Oklahoma, Sheet 30, 1930 updated to 1947 showing Enid High School with 1920 addition (compare with Figure 3).

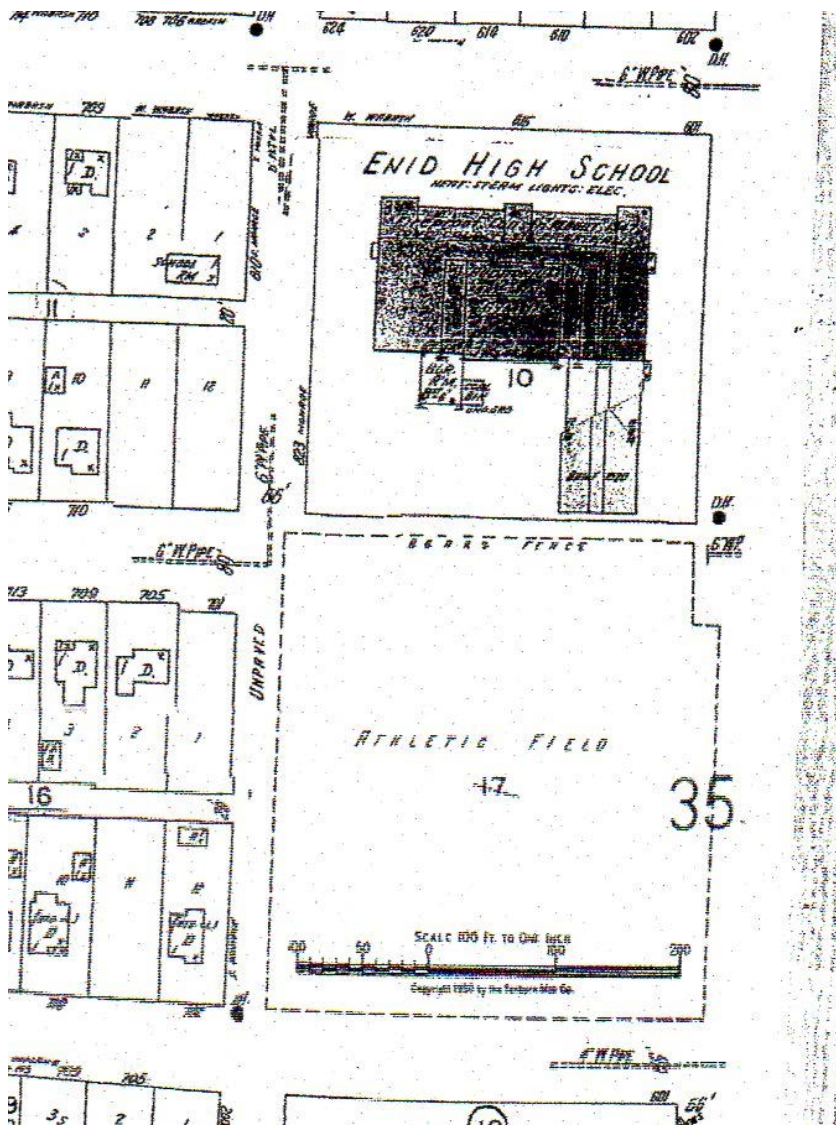

**United States Department of the Interior**  
National Park Service

**National Register of Historic Places**  
**Continuation Sheet**

Enid High School Observatory

Name of Property

Garfield County, Oklahoma

County and State

Name of multiple listing (if applicable)

Section number MAP Page 5

Map 5: Current site plan of permanent buildings on the Enid High School campus (excludes temporary classroom buildings, athletic fields, and parking lots). Area outline with heavy black lines depicts the boundaries of the nominated resource. Courtesy Enid Public Schools.

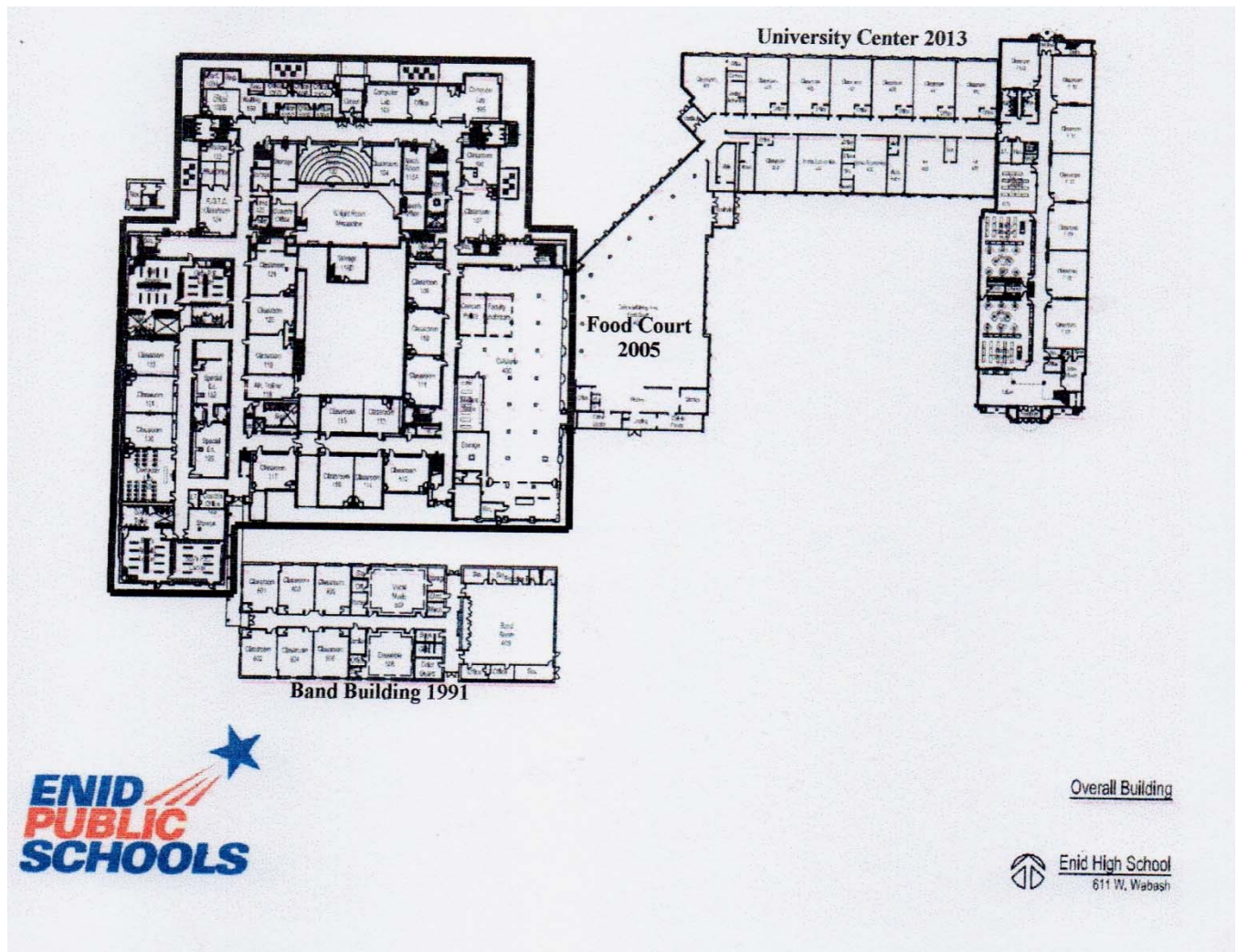

**United States Department of the Interior**  
National Park Service

**National Register of Historic Places**  
**Continuation Sheet**

Enid High School Observatory

Name of Property

Garfield County, Oklahoma

County and State

Name of multiple listing (if applicable)

Section number MAP Page 2

---



**United States Department of the Interior**  
National Park Service

**National Register of Historic Places**  
**Continuation Sheet**

Enid High School Observatory
Name of Property
Garfield County, Oklahoma
County and State
Name of multiple listing (if applicable)

Section number FIGURE Page 1

Figure 1: Rendering of Enid High School from the *Enid Daily Eagle*, February 5, 1911.

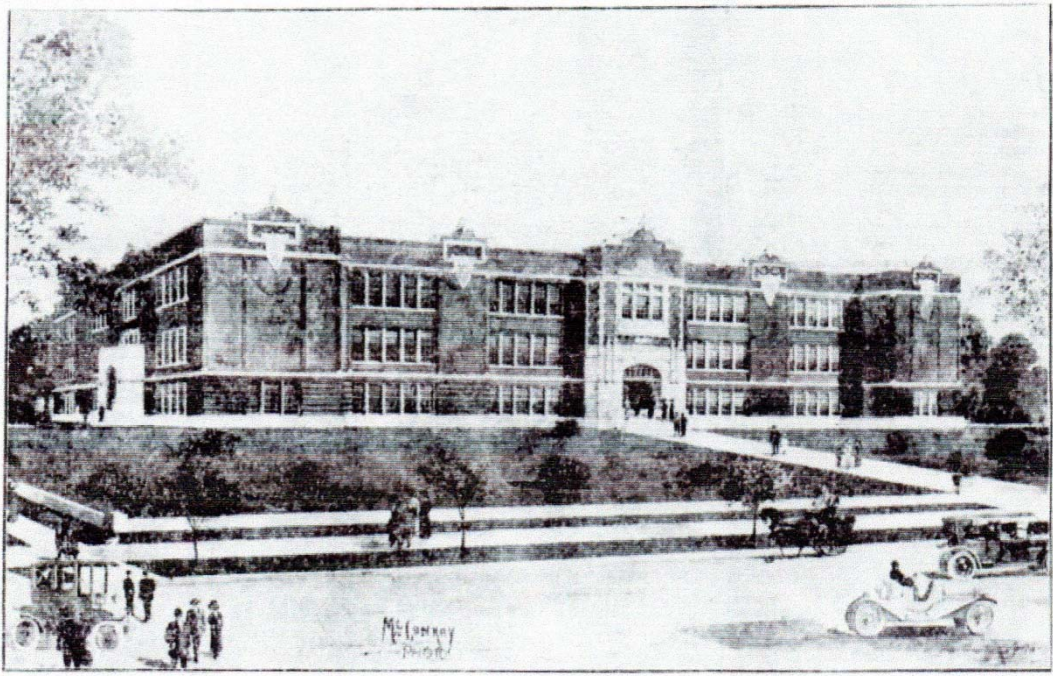

*Enid's New \$200,000 High School Building*



**United States Department of the Interior  
National Park Service**

**National Register of Historic Places  
Continuation Sheet**

Enid High School Observatory
Name of Property
Garfield County, Oklahoma
County and State
Name of multiple listing (if applicable)

Section number FIGURE Page 2

Figure 2: Photo of Enid High School from *High School Buildings*, compiled by William C. Bruce (1913), p. 82. Digitized by Internet Archive, available at [www.hathitrust.org](http://www.hathitrust.org) (accessed September 14, 2017).

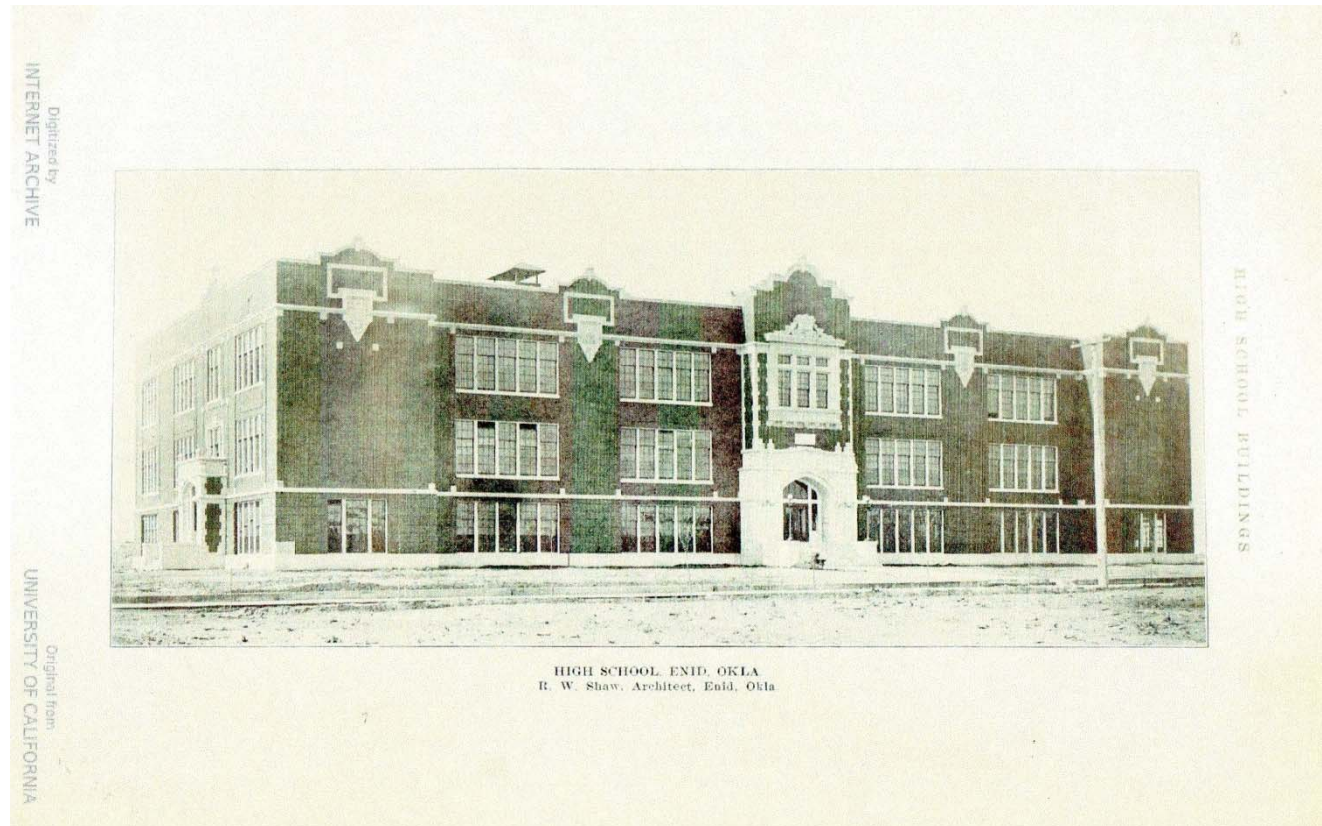

United States Department of the Interior  
National Park Service

National Register of Historic Places  
Continuation Sheet

Enid High School Observatory

Name of Property

Garfield County, Oklahoma

County and State

Name of multiple listing (if applicable)

Section number FIGURE Page 3

Figure 3: Aerial view of Enid High School with Athletic Field. View looking northeast. William Edson Photo Collection, Photograph 2008.148.035.048, date unknown [c. 1950 ] ([gateway.okhistory.org/ark:/67531/metadc963271/m1/1/?q=22Enid%20High%20School%22](http://gateway.okhistory.org/ark:/67531/metadc963271/m1/1/?q=22Enid%20High%20School%22):accessed August 1, 2017), The Gateway to Oklahoma History, [gateway.okhistory.org](http://gateway.okhistory.org); crediting Cherokee Strip Regional Heritage Center.



United States Department of the Interior  
National Park Service

Enid High School Observatory
Name of Property
Garfield County, Oklahoma
County and State
Name of multiple listing (if applicable)

# National Register of Historic Places Continuation Sheet

Section number FIGURE Page 4

Figure 4: Drawings from Patent #2,996,844, August 22, 1961 for Water-tight Construction for Observatory Domes, Astro-Dome, Inc. "FIG. 1 is a perspective view of an observatory with dome equipped with shutters constructed in accordance with the invention, the shutters being shown in open position: FIG 2 is a larger scale vertical sectional view through the dome."

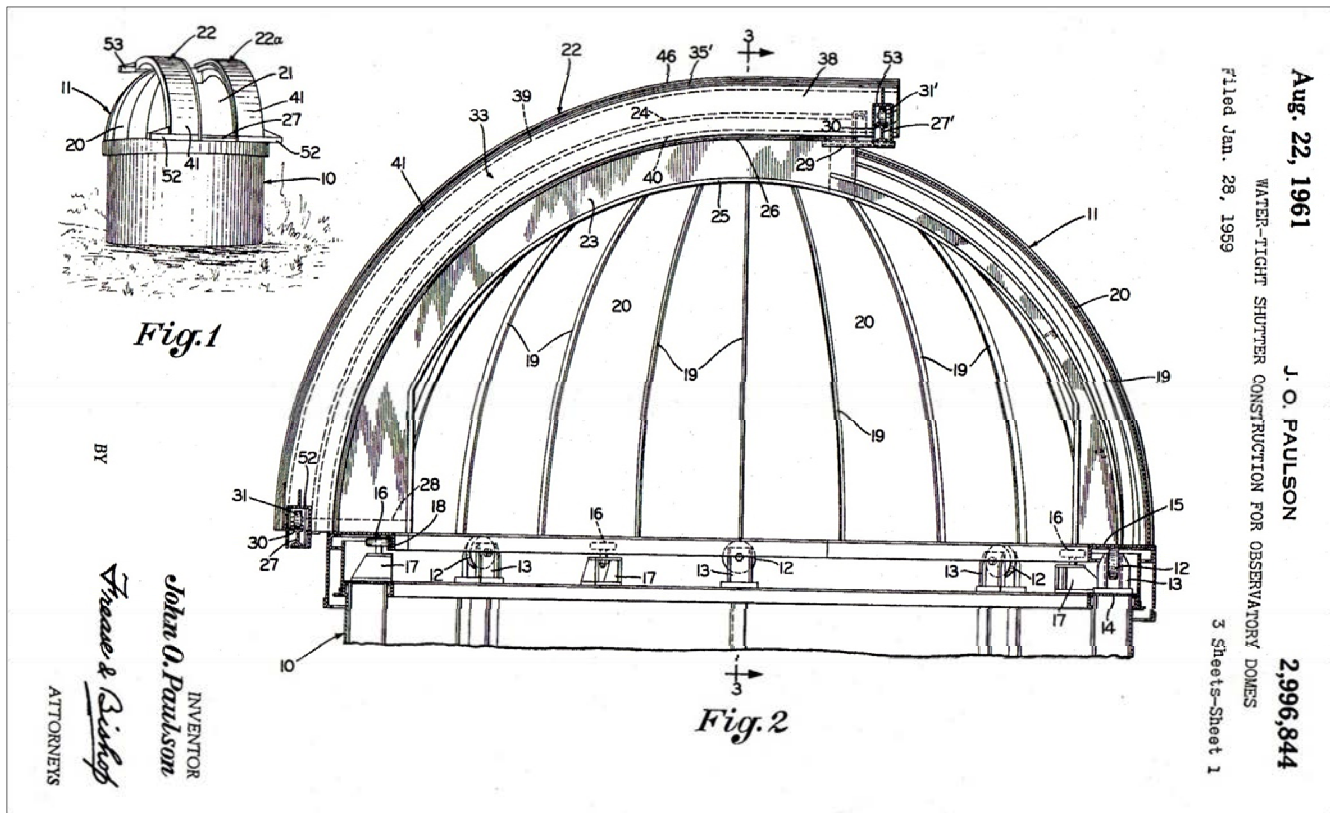

BY  
*Thorne & Bishop*  
 ATTORNEYS

*John O. Paulson*  
 INVENTOR

United States Department of the Interior  
National Park Service

National Register of Historic Places  
Continuation Sheet

Enid High School Observatory
Name of Property
Garfield County, Oklahoma
County and State
Name of multiple listing (if applicable)

Section number FIGURE Page 5

Figure 5: Drawing from Patent #2,996,844, August 22, 1961 for Water-tight Construction for Observatory Domes, Astro-Dome, Inc. "FIG.3 is a vertical sectional view through the dome with the shutters in closed position."

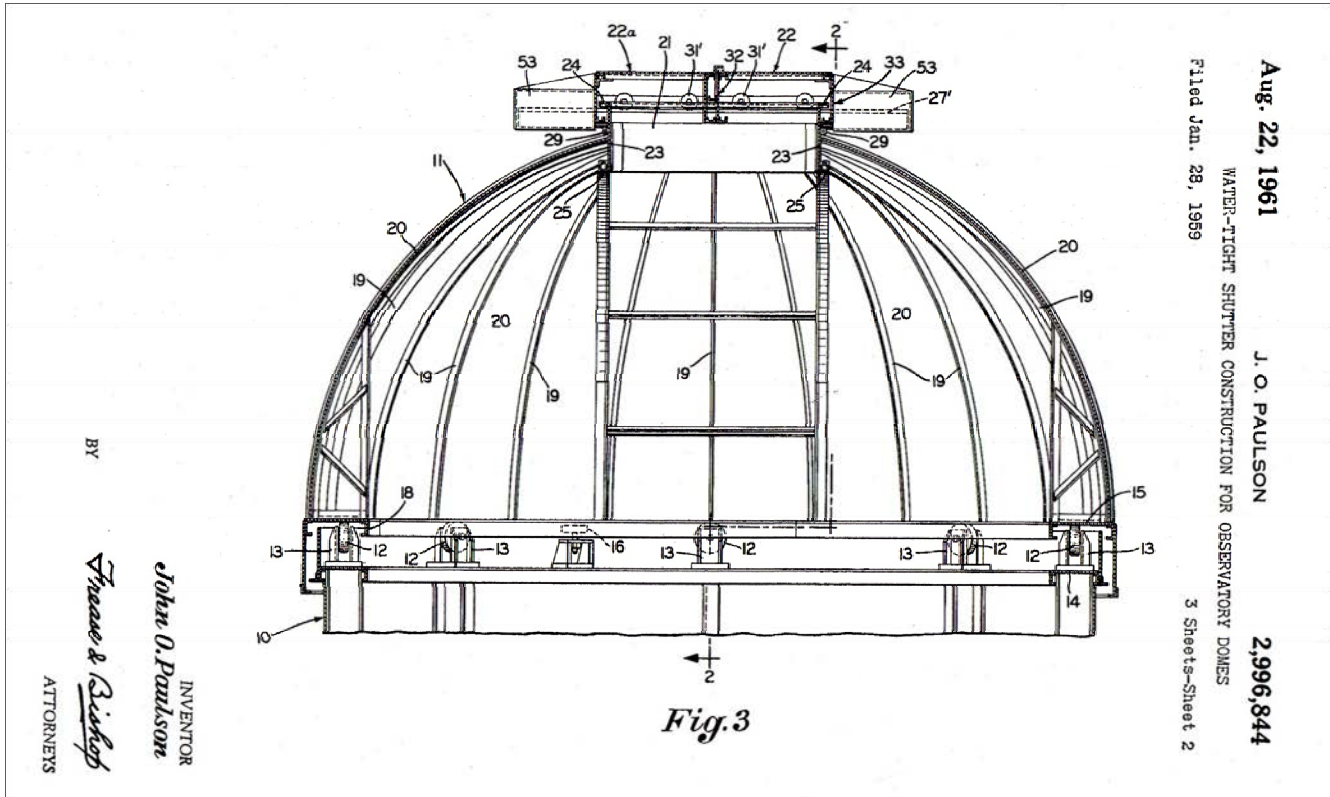

**Aug. 22, 1961**  
 J. O. PAULSON  
 2,996,844  
 WATER-TIGHT SHUTTER CONSTRUCTION FOR OBSERVATORY DOMES  
 Filed Jan. 28, 1959  
 3 Sheets-Sheet 2

BY  
*Freeman & Bickel*  
 ATTORNEYS  
 INVENTOR  
*John O. Paulson*



United States Department of the Interior  
National Park Service

Enid High School Observatory
Name of Property
Garfield County, Oklahoma
County and State
Name of multiple listing (if applicable)

# National Register of Historic Places Continuation Sheet

Section number FIGURE Page 6

Figure 6: Drawings from Patent #2,996,844, August 22, 1961 for Water-tight Construction for Observatory Domes, Astro-Dome, Inc. "FIG.4 is a fragmentary plan sectional view of a portion of the dome, showing the shutters in open position. . . FIG. 5 is an enlarged, detached, plan sectional of the shutters in closed position."

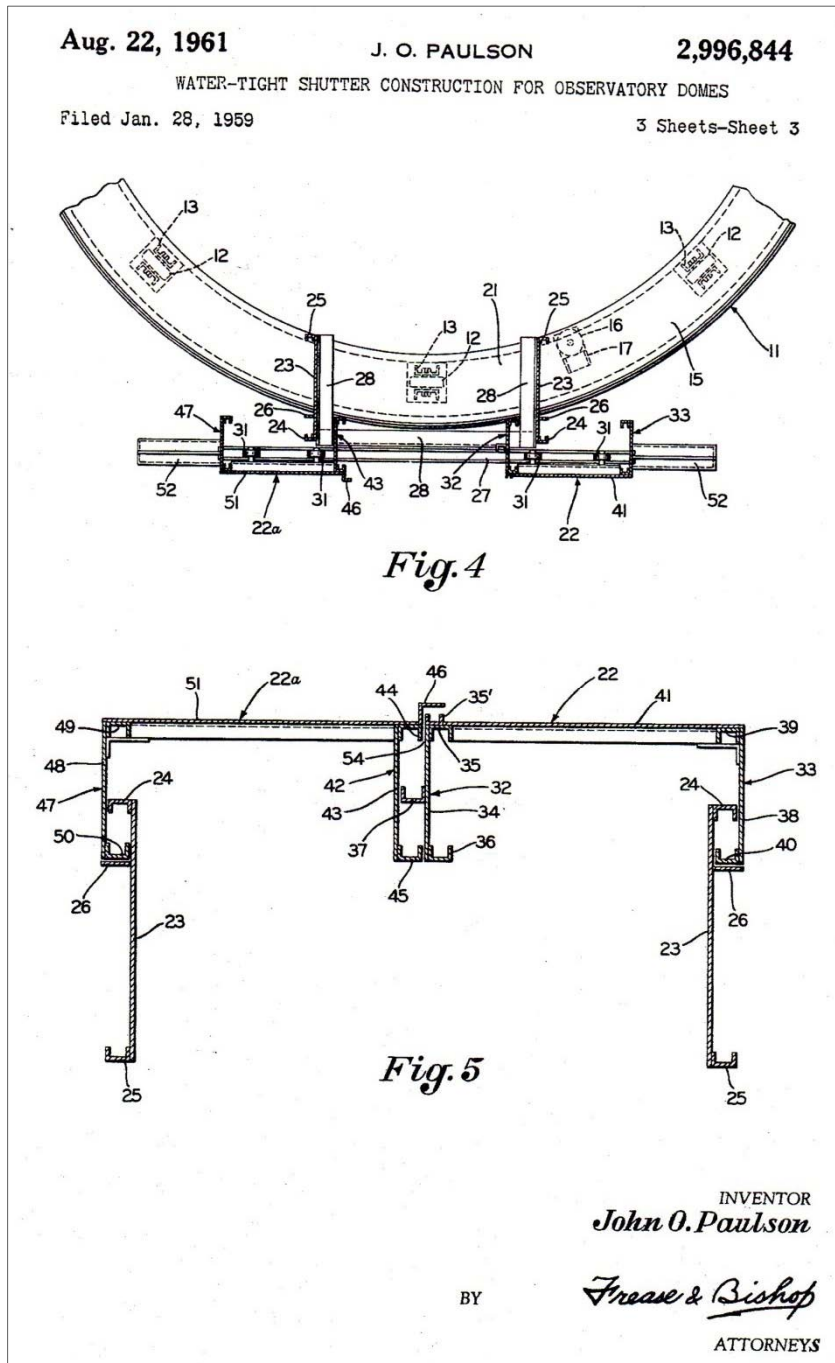

United States Department of the Interior  
National Park Service

## National Register of Historic Places Continuation Sheet

Enid High School Observatory

Name of Property

Garfield County, Oklahoma

County and State

Name of multiple listing (if applicable)

Section number FIGURE Page 7

Figure 7: Photo from EHS yearbook, *The Quill*, Volume XXXII (May 1965), p. 98. Physics teacher Jim Smeltzer is behind the two students outside the observatory. This view is looking west with the observatory's aperture facing east.



United States Department of the Interior  
National Park Service

## National Register of Historic Places Continuation Sheet

Enid High School Observatory

Name of Property

Garfield County, Oklahoma

County and State

Name of multiple listing (if applicable)

Section number FIGURE Page 8

Figure 8: Physics teacher Jim Smeltzer with students examining new telescope [Tinsley 8 inch Model D Cassegrain]. From *The Quill*, Volume XXXIII (May 1966), p. 13.

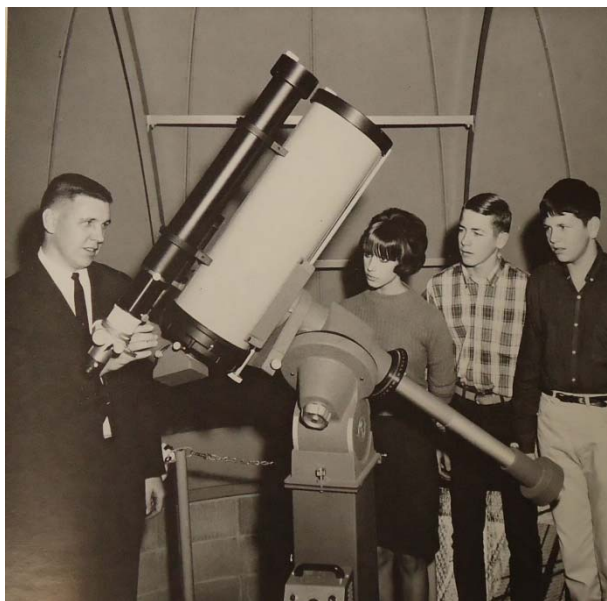
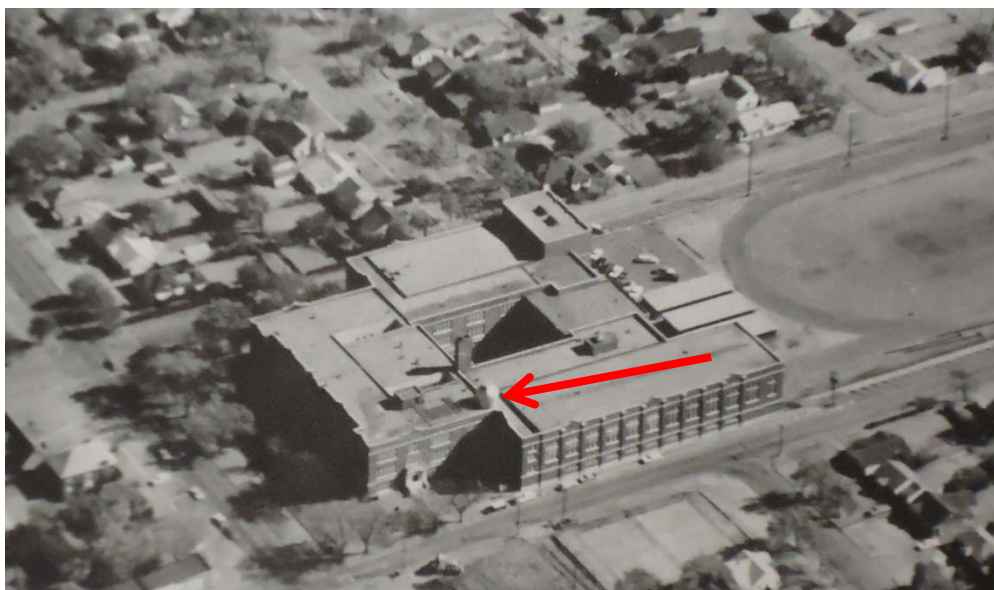

Figure 9: Aerial view of EHS showing the observatory on west side of roof. The roof is accessed through the headhouse to the left of the observatory. View looking southeast. From *The Quill*, Volume XXXIV (May 1967), p. 2.





**United States Department of the Interior**  
National Park Service

**National Register of Historic Places**  
**Continuation Sheet**

Enid High School Observatory

Name of Property

Garfield County, Oklahoma

County and State

Name of multiple listing (if applicable)

Section number FIGURE Page 9

Photo 1 of 10. North (front) elevation of Enid High School. View southwest.





**United States Department of the Interior**  
National Park Service

**National Register of Historic Places**  
**Continuation Sheet**

Enid High School Observatory

Name of Property

Garfield County, Oklahoma

County and State

Name of multiple listing (if applicable)

Section number FIGURE Page 10

Photo 2 of 10. East elevation of Enid High School. View southwest.



**United States Department of the Interior**  
National Park Service

**National Register of Historic Places**  
**Continuation Sheet**

Enid High School Observatory
Name of Property
Garfield County, Oklahoma
County and State
Name of multiple listing (if applicable)

Section number FIGURE Page 11

Photo 3 of 10. West elevation of Enid High School with view of EHS Observatory on roof. View southeast.





**United States Department of the Interior**  
National Park Service

**National Register of Historic Places**  
**Continuation Sheet**

Enid High School Observatory

Name of Property

Garfield County, Oklahoma

County and State

Name of multiple listing (if applicable)

Section number FIGURE Page 12

Photo 4 of 10. South elevation of Enid High School. View north.



**United States Department of the Interior**  
National Park Service

**National Register of Historic Places**  
**Continuation Sheet**

Enid High School Observatory

Name of Property

Garfield County, Oklahoma

County and State

Name of multiple listing (if applicable)

Section number FIGURE Page 13

Photo 5 of 10. Headhouse/room that provides access to the roof. View northeast.



**United States Department of the Interior**  
National Park Service

**National Register of Historic Places**  
**Continuation Sheet**

Enid High School Observatory

Name of Property

Garfield County, Oklahoma

County and State

Name of multiple listing (if applicable)

Section number FIGURE Page 14

Photo 6 of 10. North side of observatory with shutters open. View south.





**United States Department of the Interior**  
National Park Service

**National Register of Historic Places**  
**Continuation Sheet**

Enid High School Observatory

Name of Property

Garfield County, Oklahoma

County and State

Name of multiple listing (if applicable)

Section number FIGURE Page 15

Photo 7 of 10. Southeast side of observatory. View northwest.



**United States Department of the Interior**  
National Park Service

**National Register of Historic Places**  
**Continuation Sheet**

Enid High School Observatory

Name of Property

Garfield County, Oklahoma

County and State

Name of multiple listing (if applicable)

Section number FIGURE Page 16

Photo 8 of 10. Interior of observatory, viewing platform with Tinsley telescope. View south.



**United States Department of the Interior**  
National Park Service

**National Register of Historic Places**  
**Continuation Sheet**

Enid High School Observatory
Name of Property
Garfield County, Oklahoma
County and State
Name of multiple listing (if applicable)

Section number FIGURE Page 17

Photo 9 of 10. Interior of observatory, east stairs to viewing platform. View southeast.





**United States Department of the Interior**  
National Park Service

**National Register of Historic Places**  
**Continuation Sheet**

Enid High School Observatory

Name of Property

Garfield County, Oklahoma

County and State

Name of multiple listing (if applicable)

Section number FIGURE Page 18

Photo 10 of 10. Interior of observatory; viewing platform with Tinsley telescope. View southeast.

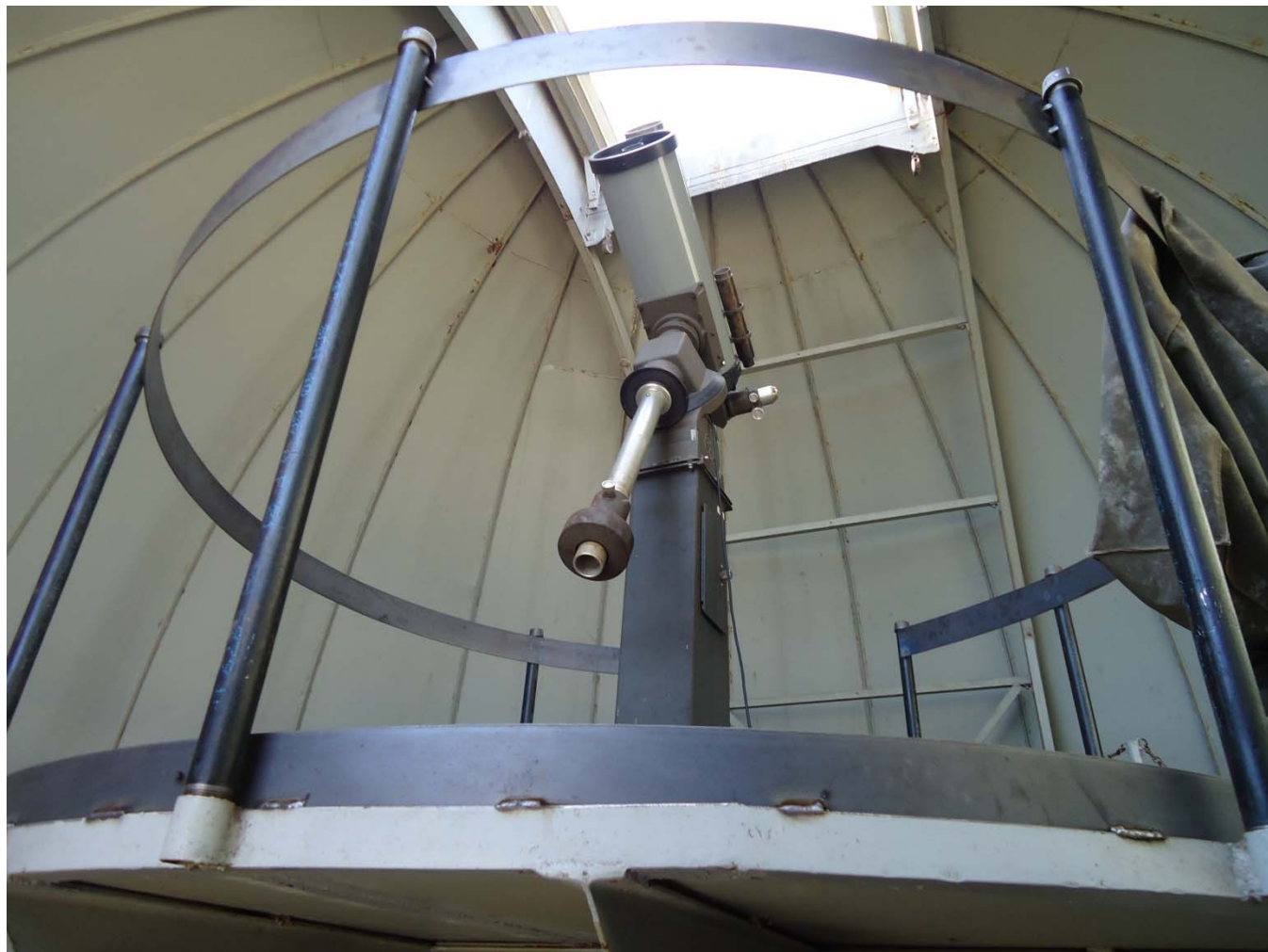

































UNITED STATES DEPARTMENT OF THE INTERIOR  
NATIONAL PARK SERVICE

NATIONAL REGISTER OF HISTORIC PLACES  
EVALUATION/RETURN SHEET

Requested Action: Nomination

Property Name: Enid High School Observatory

Multiple Name:

State & County: OKLAHOMA, Garfield

Date Received: 1/29/2018      Date of Pending List: 2/26/2018      Date of 16th Day: 3/13/2018      Date of 45th Day: 3/15/2018      Date of Weekly List:

Reference number: SG100002216

Nominator: State

Reason For Review:

<input type="checkbox"/> Appeal	<input type="checkbox"/> PDIL	<input checked="" type="checkbox"/> Text/Data Issue
<input type="checkbox"/> SHPO Request	<input type="checkbox"/> Landscape	<input type="checkbox"/> Photo
<input type="checkbox"/> Waiver	<input type="checkbox"/> National	<input type="checkbox"/> Map/Boundary
<input type="checkbox"/> Resubmission	<input type="checkbox"/> Mobile Resource	<input type="checkbox"/> Period
<input checked="" type="checkbox"/> Other	<input type="checkbox"/> TCP	<input type="checkbox"/> Less than 50 years
	<input type="checkbox"/> CLG	

Accept       Return       Reject      3/15/2018 Date

Abstract/Summary Comments: The Enid High School Observatory is of statewide significance under National Register Criterion A in the area of Education. Erected in 1963, based on plans provided by Astro-Dome Inc., the modest, steel and concrete observatory is a unique illustration of Cold War-era educational development programs in Oklahoma. The completed Observatory was a direct outgrowth of Title III of the National Defense Education Act of 1958, which promoted the strengthening of science and math instruction in secondary schools through the acquisition of modern equipment and building infrastructure. Among Oklahoma's varied projects attributed to NDEA funding, the Enid Observatory was the only such facility of its type completed in the state and remains a significant reflection of important period educational development programs in the sciences.

Recommendation/ Criteria      Accept NR Criterion A.

Reviewer      Paul Lusignan

Discipline      Historian

Telephone      (202)354-2229

Date      3/15/2018

DOCUMENTATION:      see attached comments : No      see attached SLR : **Yes**



**Oklahoma Historical Society**  
**State Historic Preservation Office**

Founded May 27, 1893

Oklahoma History Center • 800 Nazih Zuhdi Drive • Oklahoma City, OK 73105-7917  
(405) 521-6249 • Fax (405) 522-0816 • [www.okhistory.org/shpo/](http://www.okhistory.org/shpo/)



January 26, 2018

J. Paul Loether  
Keeper and Chief National Register and  
National Historic Landmark Programs  
National Park Service  
1849 C Street NW, Mail Stop 7228  
Washington D.C. 20240

Dear Mr. Loether:

We are pleased to transmit five National Register of Historic Places nominations for Oklahoma properties. The nominations are for the following properties:

1210-1212-1214 North Hudson Historic District, Oklahoma City, Oklahoma County  
Dunbar Elementary School, 1432 Northeast Seventh Street, Oklahoma City,  
Oklahoma County  
First National Bank and Trust Company Building, 120 North Robinson Avenue,  
Oklahoma City, Oklahoma County  
Enid High School Observatory, 611 West Wabash Avenue, Enid, Garfield County  
Okmulgee Country Club and Golf Course, 1400 South Mission Lane, Okmulgee,  
Okmulgee County

The member of the Historic Preservation Review Committee (state review board), professionally qualified in the field of prehistoric archeology was absent from the public meeting at which each of these nominations was considered and the recommendation to the State Historic Preservation Officer was formulated. However, the member possessing the requisite professional qualifications for evaluation of each nominated property was present and participated in the recommendation's formulation.

We look forward to the results of your review. If there any further questions regarding the nominations, please do not hesitate to contact me.

Sincerely,

A handwritten signature in black ink, appearing to read "Lynda Ozan".

Lynda Ozan  
Deputy State Historic  
Preservation Officer

Enclosures