

KENTUCKY HISTORIC RESOURCES INVENTORY

Site No. GDL 53

1. Historic Name(s) <u>Billy Ball House</u> Original Owner <u>Pawlings</u>		22. ADD/County <u>BLUEGRASS/ GARRARD</u> <span style="float:right; border: 1px solid black; padding: 2px;">040</span>	
2. Present Name <u>Edna Reynolds' House</u>		23. U.S.G.S. Quadrant (15'/75') <u>Lancaster</u> <span style="float:right; border: 1px solid black; padding: 2px;">G.I.S. Mod. [ ] [ ] [ ]</span>	
3. Location <u>209 Richmond Street</u>		24. UTM Reference <span style="border: 1px solid black; padding: 2px;">16</span> <span style="border: 1px solid black; padding: 2px;">71</span> <span style="border: 1px solid black; padding: 2px;">39</span> <span style="border: 1px solid black; padding: 2px;">40</span> <span style="border: 1px solid black; padding: 2px;">41</span> <span style="border: 1px solid black; padding: 2px;">6</span> <span style="border: 1px solid black; padding: 2px;">61</span> <span style="border: 1px solid black; padding: 2px;">20</span> Zone Easting Northing	
4. Owner's Name <u>Mrs. Edna Underwood Reynolds</u>		25. Coordinate Accuracy <span style="float:right; border: 1px solid black; padding: 2px;">[ ]</span>	
5. Owner's Address <u>Richmond Road, Lancaster, Ky. 40444</u>		26. Prehistoric Site Object Historic Site Structure <input checked="" type="checkbox"/> Building Other	
6. Open to Public Yes <input type="checkbox"/> No <input checked="" type="checkbox"/>	7. Visible from road Yes <input checked="" type="checkbox"/> No <input type="checkbox"/>	8. Ownership <span style="float:right; border: 1px solid black; padding: 2px;">X</span> Private <input type="checkbox"/> Local <input type="checkbox"/> State <input type="checkbox"/> Federal <input type="checkbox"/>	
9. Local Contact/Organization <b>GARRARD COUNTY HISTORICAL SOCIETY</b>		27. National Register District Name: <b>Multiple Resources of Lancaster</b>	
10. Site Plan with North Arrow 		28. Significance Evaluation <span style="float:right; border: 1px solid black; padding: 2px;">D</span> <b>Nat. Reg. Criteria</b>	
		29. Status <span style="float:right; border: 1px solid black; padding: 2px;">Date</span> National Landmark <input type="checkbox"/> National Register <input type="checkbox"/> Landmark Certificate <input type="checkbox"/> Kentucky Survey <input type="checkbox"/> Local Landmark <input type="checkbox"/> HABS/HAER <input type="checkbox"/>	
18. Description Two story, 3 bay frame residence with gable roof; log structure beneath siding; limestone foundation; additions to rear. Log structure- 27 x 18'		11. Architect	
		12. Builder	
19. History Lot #56 was originally owned by the Pawling family and a log structure was erected. The deeds from then to the present owner are few but this has been rental property many years. W. B. (Billy) Ball and his mother owned the property from 1893 to 1933, and the alley running on the West side of the property is called Ball's Alley. Today the property is owned by Edna Reynolds who inherited it from her father T. J. Underwood.		13. Date <u>1830-1840</u> A. <input checked="" type="checkbox"/> B. <input type="checkbox"/>	
		14. Style A. Vernacular <input checked="" type="checkbox"/> B. <input type="checkbox"/>	
20. Significance <u>ONE OF SEVEN LOG STRUCTURES STILL EXISTING IN ORIGINAL TOWN PLAN.</u>		15. Original Use <u>S.F. Residence</u> <span style="float:right; border: 1px solid black; padding: 2px;">A</span>	
		16. Present use <u>Vacant</u>	
21. Source of Information Garrard County Court House Records- C. M. Ballard Mr. W. B. Mason		17. Condition <u>Vacant</u> <span style="float:right; border: 1px solid black; padding: 2px;">D</span>	
		No. Stories <u>Two</u> <span style="float:right; border: 1px solid black; padding: 2px;">C</span> Single Pile <input checked="" type="checkbox"/> NA <input type="checkbox"/> Double Pile <input type="checkbox"/>	
(Continue on Back)		Floor Plan Rectangular <u>Single cell</u> <span style="float:right; border: 1px solid black; padding: 2px;">B</span>	
		Structural Fabric Log/Frame A. <input checked="" type="checkbox"/> B. <input checked="" type="checkbox"/> Decorative Fabric A. <input type="checkbox"/> B. <input type="checkbox"/>	
34. Prepared by: <b>HELEN POWELL</b>		30. Historic Theme Primary <input type="checkbox"/> Secondary <input type="checkbox"/> Other <input type="checkbox"/>	
		31. Endangered Yes <input type="checkbox"/> No <input type="checkbox"/>	
35. Organization <b>CARMAN AND POWELL, INC.</b>		32. Preservation Project Status <span style="float:right; border: 1px solid black; padding: 2px;">[ ]</span>	
		Actual Cost in \$1,000s <span style="float:right; border: 1px solid black; padding: 2px;">[ ] [ ] [ ] [ ] [ ] [ ] [ ] [ ] [ ] [ ]</span>	
36. Date <u>1983</u>		33. ATTACH PHOTO 	
		Roll No. _____ Picture No. _____ Direction _____	
37. Revision Dates _____ 38. Staff Review _____		39. _____	
		40. _____	

KENTUCKY HISTORIC RESOURCE INVENTORY SUPPLEMENT  
BOUNDARY AND LOCATION INFORMATION

Historic Property Name Ball House Site # GDL 53  
Multiple Resource/Thematic Nomination Title Multiple Resources of Lancaster

U.T.M. Coordinates - List multiple UTM's if property is ten or more acres.

A. \_\_\_\_\_ D. \_\_\_\_\_  
B. \_\_\_\_\_ E. \_\_\_\_\_  
C. \_\_\_\_\_ F. \_\_\_\_\_

Verbal Boundary Description \_\_\_\_\_ Acreage .23

From a point in the north right of way of Richmond St. 200feet east of the intersection of Richmond St. and Campbell St.; then 60 feet east to a point; then 165 north to a point; then 60 feet west to a point; then 165 feet south to a point.

Sketch of Site Plan (Showing outbuildings, structures, landscape features and the site boundary as described above.)

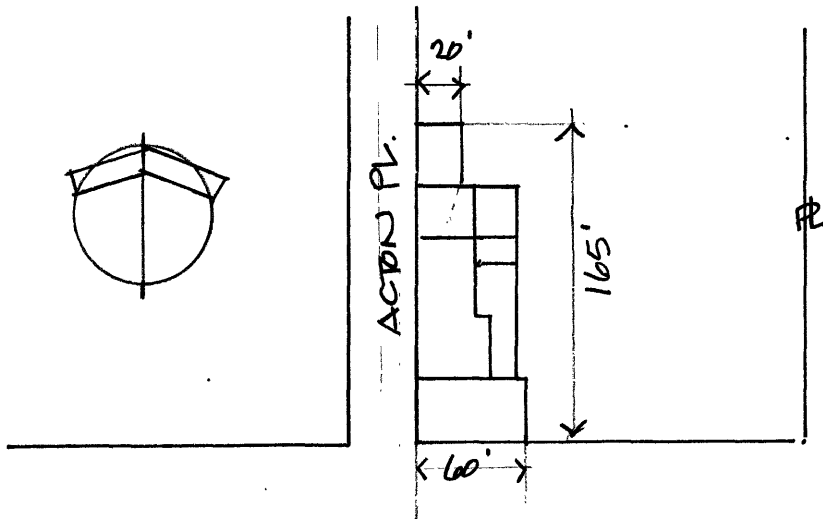

Official Courthouse Property Reference: